

V40 ROTARY BRUSH CUTTER STANDARD AND OPEN DECK

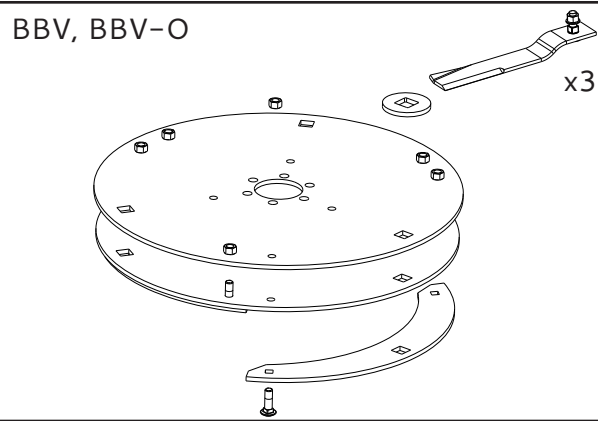

2 Steel Plates • 3/8" Grade 50
Total Plate Thickness: 3/4"

MODEL	DIAMETER	WEIGHT (LBS)
60"	24"	170
72"	30"	220

V50 ROTARY BRUSH CUTTER STANDARD AND FLOATING DECK

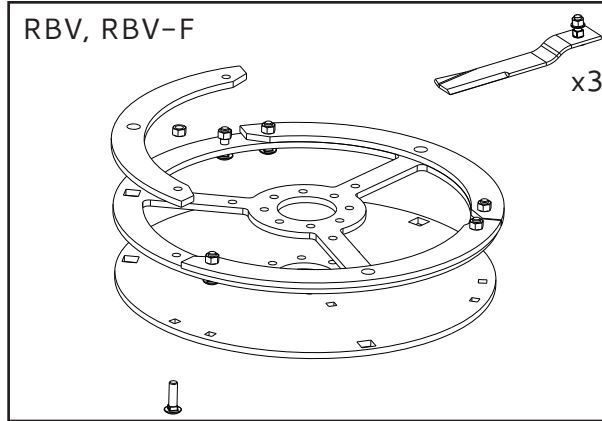

2 Steel Plates • 1/2" Grade 50
Total Plate Thickness: 1"

MODEL	DIAMETER	WEIGHT (LBS)
60"	24"	170
66"	30"	215
72"	30"	220
78"	30"	225

V60 INDUSTRIAL ROTARY BRUSH CUTTER

ALL INFO SUBJECT TO
CHANGE WITHOUT NOTICE.

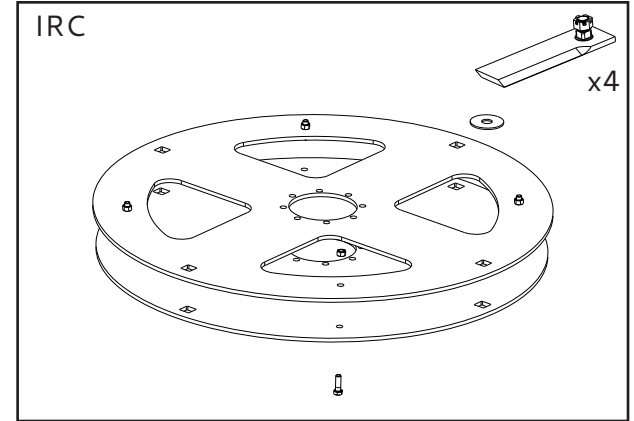

2 Steel Plates • 1/2" Grade 80
Total Plate Thickness: 1"

MODEL	DIAMETER	WEIGHT (LBS)
60"	41"	400
72"	49"	550
78"	55"	610

V50 ROTARY BRUSH CUTTER - OPEN FRONT DECK

2 Steel Plates • Plate Thickness: 3/8" • Total Plate Thickness: 3/4" • Flywheel Weight: 275 lbs
• Bottom plate and spacer made from Grade 80 steel, top plate made from Grade 50 steel.

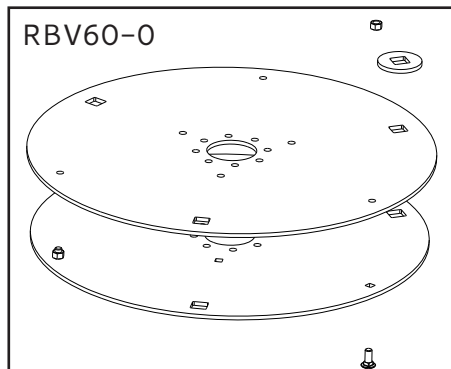
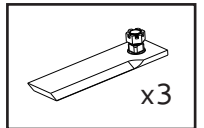

36" Flywheel Diameter

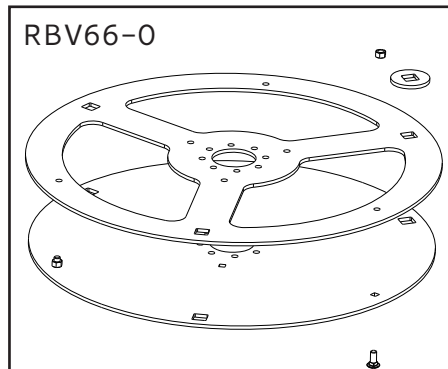

42" Flywheel Diameter

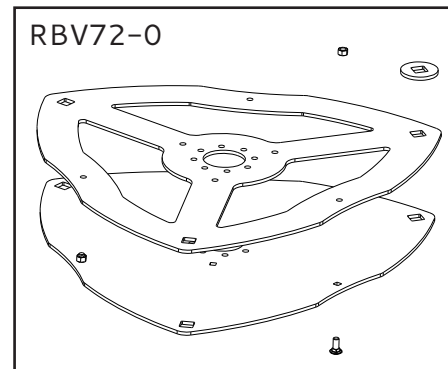

48" Flywheel Diameter

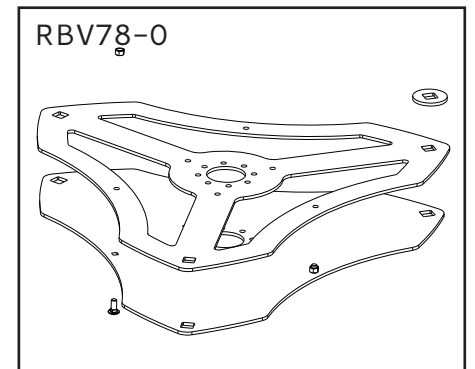

54" Flywheel Diameter