

Rotary Brush Cutter – Standard



Features

- ✔ Cuts through brush up to three inches in diameter with ease, while three-blade design produces a superior finish.
- ✔ Three-blade cutting system, mounted to a large circular flywheel ensuring flywheel bounces off stumps rather than catching and damaging the motor.
- ✔ Heavy-duty construction for pushing over brush and small trees.
- ✔ Standard replaceable front skid shoes.
- ✔ Standard dual hydraulic pressure relief valves with dynamic braking stops the 150–215 lb. flywheel in 7–10 seconds.
- ✔ Multiple motor configurations to match loader’s hydraulic system.

DO NOT OPERATE ROTARY BRUSH CUTTER WITHOUT A SHATTERPROOF CAB DOOR ON LOADER

OPTION: Rear Roller



Limits gouging and compacts chopped material.

OPTION: Swivel Casters



360° rotating swivel casters limit gouging.

Rotary Brush Cutter – Standard Deck Specifications

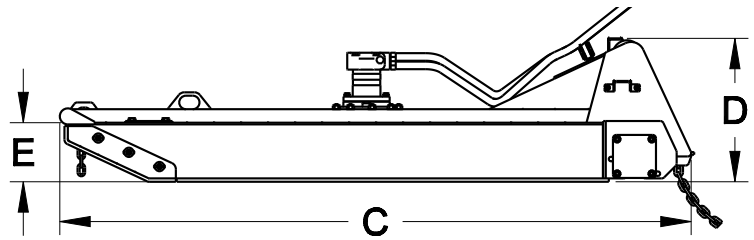
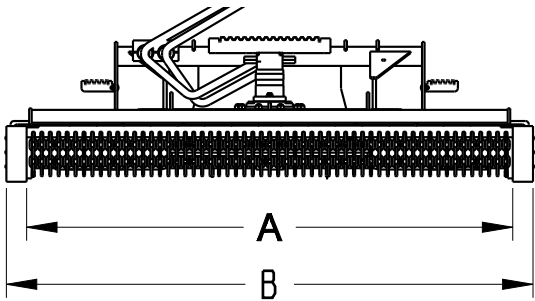

MODEL	RBV60	RBV66	RBV72	RBV78
(A) Cut Width (Inches)	60.0	66.0	72.0	78.0
(B) Overall Cutter Width (Inches)	66.0	72.0	78.0	84.0
(C) Cutter Depth (Inches)	81.8	87.8	93.8	99.8
(D) Cutter Height (With Sides)	20.9			
(E) Deck Height (Inches)	8.8			
Minimum Cut Height (Inches)	1.8			
Cutting Capacity, Diameter (Inches)	3			
Recommended Flow Rate (GPM)	14-25 Standard Flow, 25-42 High Flow			
Approximate Weight (Pounds)	1180 ¹	1325 ¹	1435 ¹	1540 ¹
Recommended Loader Capacity (Pounds)	Greater than 1500			

¹ High flow motor options add approximately 70 pounds to model weight.

Additional Info

- 1/2" x 4" single, side, updraft blades.
- Hoses from cutter to loader and couplers included.

BLADE TIP SPEEDS (FPM)

Blade tip speeds at specified flow rates in gallons per minute (GPM).

Blade tip speeds listed in feet per minute.

Standard Flow Models			High Flow Models		
MODEL	14 GPM Minimum	18 GPM Maximum	MODEL	25 GPM Minimum	33 GPM Maximum
RBV60-18	10,367	13,329	RBV60-HF33	11,483	15,157
RBV66-18	11,404	14,662	RBV66-HF33	12,630	16,672
RBV72-18	12,440	15,995	RBV72-HF33	13,779	18,188
RBV78-18	13,477	17,328	RBV78-HF33	14,927	19,704
Standard Flow Models			High Flow Models		
MODEL	18 GPM Minimum	25 GPM Maximum	MODEL	33 GPM Minimum	42 GPM Maximum
RBV60-25	10,534	14,631	RBV60-HF42	10,062	12,806
RBV66-25	11,588	16,094	RBV66-HF42	11,068	14,087
RBV72-25	12,641	17,557	RBV72-HF42	12,074	15,367
RBV78-25	13,695	19,020	RBV78-HF42	13,081	16,648

Specifications and designs are subject to change without notice.



Virnig Manufacturing Inc.
 800-648-2408
 attachments@virnigmfg.com
 www.virnigmfg.com

Rotary Brush Cutter – Standard Deck Additional Pictures



Push over and cut through brush with ease.



Three-blade cutting system mounted to a large circular flywheel.

Specifications and designs are subject to change without notice.



Virnig Manufacturing Inc.
800-648-2408
attachments@virnigmfg.com
www.virnigmfg.com