

# High Dump Bucket



## Features

- ❖ Increases life and reach for easier loading.
- ❖ Increases vertical lift by 44" and horizontal reach by 13" (approximately).
- ❖ Ideal for loading feed mixers and trucks.
- ❖ Windows in bucket for increased visibility.
- ❖ Corrosion, dent and flake resistant NitroSteel® cylinder rods made in the USA.
- ❖ 3/4" x 6" weld-on edge with holes for optional edges.
- ❖ Machine specific hydraulic package available.

## OPTION: Standard Bolt-On Edge



Reversible 5/8" x 8" double-bevel, bolt-on wear edge with 5/8" holes spaced 6" on center.

## OPTION: Serrated Bolt-On Edge



Reversible 3/4" x 8" single-bevel, serrated bolt-on wear edge with 5/8" holes spaced 6" on center.

# High Dump Bucket Specifications

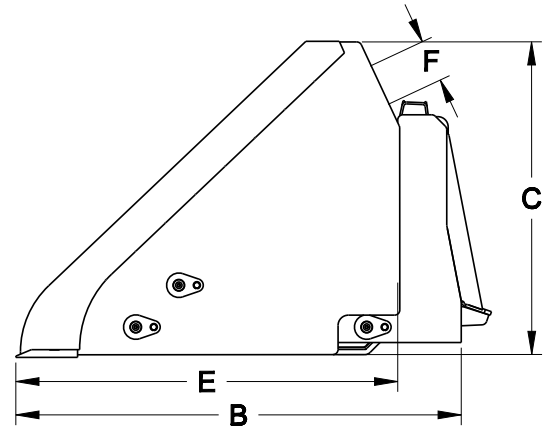
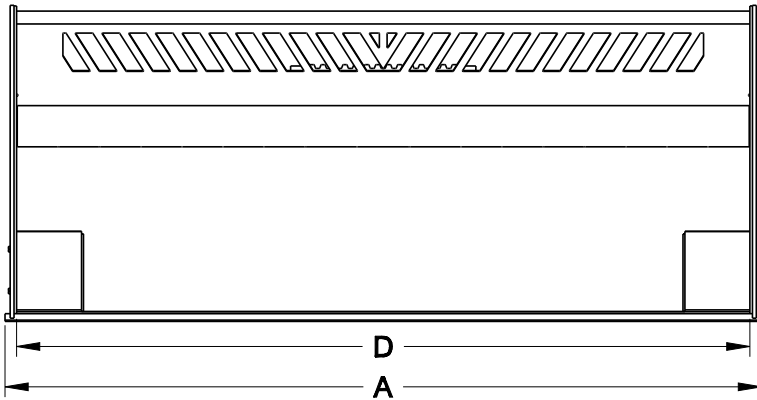

MODEL	DMP72	DMP84	DMP96
(A) Overall Bucket Width (Inches)	73.5	85.5	97.5
(B) Bucket Depth (Inches)	47.3		
(C) Bucket Height (Inches)	29.8		
(D) Inside Bucket Width (Inches)	71.3	83.3	95.3
(E) Inside Bucket Depth (Inches)	37.0		
(F) Window Height (Inches)	4.0		
(G) Dump Angle (Degrees)	86		
Struck Capacity (Cubic Feet)	27.4	32.0	36.6
Heaped Capacity (Cubic Feet)	32.9	38.4	43.9
Structural Wear Bars Under Bucket (1/2" x 4")	4	4	4
Approximate Weight (Pounds)	1010	1100	1180
Recommended Loader Capacity (Pounds)	Greater than 1800		

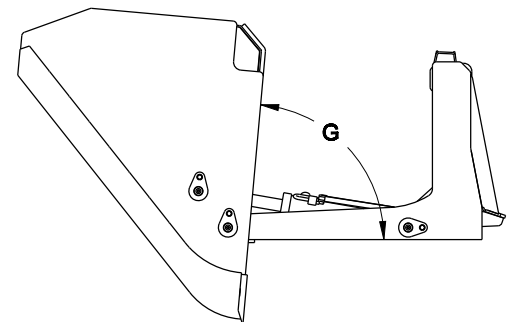

\*Virnig Mfg. Inc. High Dump Bucket will increase vertical lift by approximately 44" and reach by approximately 13". Vertical lift and reach will vary by loader.

### Additional Info

- 1 9/16" diameter hinge pins.
- 2 1/2" bore, 8 3/8" stroke cylinders with 1 1/2" NitroSteel® cylinder rods and 1 1/4" cylinder pins.
- Hoses from bucket to loader and couplers included.

Specifications and designs are subject to change without notice.



**Virnig Manufacturing Inc.**  
 800-648-2408  
 attachments@virnigmfg.com  
 www.virnigmfg.com

# High Dump Bucket Edge Options



## STANDARD BOLT-ON EDGE

- ✔ Extends life of bucket edge.
- ✔ Reversible 5/8" bolt-on wear edge with 5/8" holes spaced 6" on center.
- ✔ Available on all Virnig Buckets except skeleton style.



## SERRATED BOLT-ON EDGE

- ✔ Excellent alternative to toothbar for chiseling and breaking up compacted soil.
- ✔ Single bevel, 3/4" x 8", serrated bolt-on edge with 5/8" holes spaced 6" on center.
- ✔ Available on all Virnig Buckets except skeleton style.