

V50 Rotary Brush Cutter-Standard Deck (RBV) (Standard and High Flow Models)

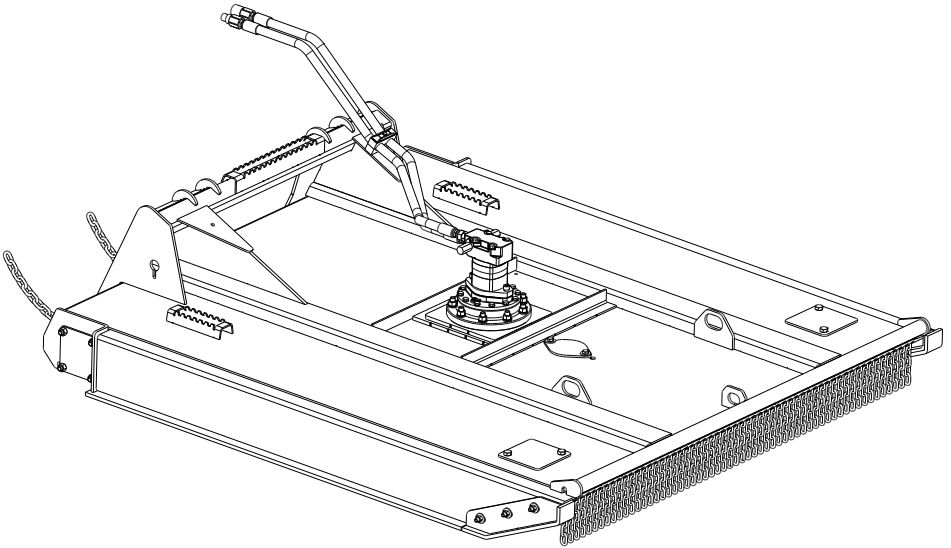

Model Number RBV.

Serial Number _____.

Maximum Flow Rate GPM.

Serial Number 128311, 130058-135126 and 136598

Manufacture Date 01/22/18 – 06/24/18

Phone: 320-393-7080

10/05/10
Revised 01/22/18

RBV

Features of Virnig Mfg. Inc. V50 Rotary Brush Cutter-Standard Deck include:

- 4" diameter maximum cutting capacity.
- Four hydraulic motor options with standard flow rates covering 14-25 gpm and high flow rates covering 25-42 gpm.
- Standard dual hydraulic pressure relief valves with dynamic braking.
- Standard flow maximum operating pressure of 3500 psi. High flow maximum operating pressure of 4000 psi.
- 1100 psi maximum back pressure.
- 1/2" x 4" single side, updraft blades.
- Standard large 3 blade circular flywheel for smoother operation.
- Standard replaceable front skid shoes.
- Standard spindle guard protects spindle output shaft seal.
- Recommended for skid loaders with a lift capacity over 1500 lb.

Initial Use

- Read and understand all warning information in this manual before operating this attachment.
- Check that quick-tach on frame fits onto skid loader properly. Pins must engage through 3/8" plates at bottom of quick-tach.
- Slowly roll back attachment. Make sure there is no interference between attachment and skid loader.
- Make sure hoses do not pinch during roll back.
- Attach Lift Limit Chains. (See details in "Operation" section of this manual.)
- Flow rate **cannot** exceed maximum flow rate noted on the label on the surface of the cutter's deck.
- Start the V50 Rotary Brush Cutter-Standard Deck at an idle, bring up to engine operating rpm, stop cutter (see "Operation" section of this manual) and check for oil leaks per instructions in "Maintenance" section of this manual.
- Never exceed the maximum attachment operating pressure of 3500 psi for standard flow or 4000 psi for high flow. Pressures in excess of noted maximum may generate additional heat and shorten component life.
- Use of supplied case drain line on high flow units is highly recommended. The use of the case drain line will greatly increase motor life.

Operation

- Always follow safety and operating information in this manual.
- Always follow all safety and operating instructions of skid loader.
- Never remove material deflectors or safety labels. Make sure all safety labels are in place. Refer to this manual for label locations.
- Never operate the V50 Rotary Brush Cutter-Standard Deck unless you have been properly trained.
- Loader should be equipped with a shatterproof door for safe operation of the V50 Rotary Brush Cutter-Standard Deck.
- Lift Limit Chains must be installed for safe operation of the V50 Rotary Brush Cutter-Standard Deck. Both chains need to be attached to the loader. For loaders with one front tie down, run both chains to the one tie down. If the loader has two front tie downs, run one chain to each. Chain length should be adjusted so the rear of the deck (near the loader) should not be allowed to be raised higher than 12" above the ground. Both chains need to be adjusted to the same length to prevent unnecessary twisting of loader arms. The V50 Rotary Brush Cutter-Standard Deck should NEVER be operated with the deck at or above the lower level of the loader cab glass. Doing so creates a great risk of damage to the loader as well as injury or death of the operator.



Correct installation of lift limit chain (Item #11) and lift limit retainer plate (Item #18).

Operation (cont.)

- Keep bystanders back 200 feet at all times. Do not operate near buildings, traffic, pets or livestock.
- Never allow riders on the V50 Rotary Brush Cutter-Standard Deck, even when blades are not rotating.
- Check that all bolts are tight and that no parts are damaged. Make sure blades swing freely. Check blades for cracks or damage, replace as needed. Blades should always be replaced in sets. Never try to straighten or weld on blades.
- Never cut material larger than 4" diameter.
- Before cutting an area, thoroughly check for obstructions such as pipes, fence posts, wire/cable, rocks, etc. Remove obstructions if possible, flag any obstructions too large to move.
- Engage hydraulics at an idle, then bring loader to desired engine operating rpm. The V50 Rotary Brush Cutter-Standard Deck should be stopped before slowing engine rpm. It is equipped with dynamic braking and an anti-cavitation valve. Quickly throttling down the loader before disengaging the hydraulics has a greater potential to damage the cutters hydraulic system than disengaging the hydraulics at operating rpm.
- If blade rotation does not match your preferred detent position, the couplers can be switched on the hoses.
- Use extreme care when cutting close to fences, ditches, large obstacles, and on hillsides.
- Do not operate on or drive across steep slopes.
- Stop and inspect entire unit for damage after striking any foreign objects. Replace or repair any damaged components before continuing.
- Before dismounting, lower lift arms to stops, place cutter flat on the ground, disengage hydraulics, stop engine, engage parking brake and make sure all rotation has stopped.
- Always relieve pressure before disconnecting hydraulic hoses.
- Clean any debris from attachment. Pay special attention to any debris in quick-tach area.
- The V50 Rotary Brush Cutter-Standard Deck Standard Flow can rotate in either direction, the operator must determine which direction the cutter is spinning. When looking top down on the deck, the V50 Rotary Brush Cutter-Standard Deck should spin in a counter clockwise direction. If, during the initial use, the V50 Rotary Brush Cutter-Standard Deck does not seem to have power, cuts poorly or easily stalls, the cutter is probably rotating in the incorrect direction. Change the direction of the cutter by reversing the direction of flow after bringing the unit to a complete stop.

Operation (cont.)

- The V50 Rotary Brush Cutter-Standard Deck High Flow will rotate in only one direction. The operator should verify the direction the cutter is spinning. When looking top down on the deck, the Industrial Rotary Cutter should spin in a counter clockwise direction. If cutter does not spin in the proper direction, please contact Virnig Mfg Inc. Reversing hydraulic flow will generate no movement of cutter.

Cutting Recommendations

- To minimize overheating risk, continuous rotation of the blades is recommended. If the cutter stalls, disengage hydraulics and remove cutter from material before restarting.
- Engage hydraulics at an idle. When blades are rotating smoothly, bring loader to engine operating rpm. Do not engage cutter into material to be cut until blades are running smoothly at engine operating rpm.
- If blades are slowing or loader engine rpm's are decreasing, decrease travel speed into material to be cut or take less than full width cuts to maintain blade speed.
- For tall grass and heavy vegetation, raise the back of the cutter 2" - 3" off of the ground to better allow material to exit the cutter. Place the front skid shoes 1" - 2" off of the ground and drive into material. Never drive with the front of the cutter raised to a height where your view is obstructed. Never raise the unit to a height to expose yourself or others to the rotating blades. If you can see the blades, the unit is raised too high.
- When cutting large brush/small trees up to 4" diameter, keep the back of the cutter at or near ground level and roll the front of the cutter so it is 12" - 24" above the ground. Drive slowly into the material. The tilt cylinders of the loader can be used to bend over small trees. As the tree bends over, the blades will cut it off. The tree can be mulched by rotating the front of the cutter upward and driving over it moving forward. The tree can be further mulched by rolling the front of the cutter downward near ground level and backing up. Repeat as needed. The back of the cutter should be at or near ground level.

Maintenance

*Before each use and after every 10 hours of operation

- Make sure all safety labels are in place, look in this manual for locations.
- Check lubricant level in the V50 Rotary Brush Cutter-Standard Deck bearing adapter (spindle). Remove the plug on the side of the bearing housing, just above the mount flange with bolts holding it to the cutter deck. If no lubricant comes out of the hole, fill until lubricant comes out of the hole. Reinstall plug. Oil can be added through the plug located on or near the top surface of the bearing adapter. Required lubricant for bearing adapters is 80W-90 Gear Oil, API-GL-5 approved. If empty, bearing adapter holds 14 fluid ounces of lubricant.
- If the V50 Rotary Brush Cutter-Standard Deck is equipped with the optional rear roller, grease the 2 roller mount bearings at rear of cutter.
- If the V50 Rotary Brush Cutter-Standard Deck is equipped with the optional front casters, grease the 2 fittings located in the wheel pins.
- Check for loose, worn, or missing parts, repair or replace as needed.
- Check that all bolts are tight and that no parts are damaged. Pay special attention to the 8 bolts (Item #26) that hold the Blade Carrier Assembly (Item #23) to the Bearing Adapter (spindle) (Standard Flow-Item #44 or High Flow-Item #63). If any of the 8 bolts are loose, remove, apply a thread locking compound and re-install and torque to proper value. See "Bolt Torque Chart" in this manual for proper torque values.
- Make sure blades swing freely. Check blades for cracks or damage, replace as needed. Blades should always be replaced in sets. Never try to straighten or weld blades. Do not heat or pound on blades. Blades should be replaced if excessively nicked or worn. Bent blades need to be replaced immediately. Blade bolts and nuts **MUST** be replaced with the blades. Blades can be sharpened. Blades should be sharpened at the same time and same amount to maintain balance of the cutter. For best blade wear, do not sharpen blades to an edge, leave the blades 1/32" - 1/16" blunt.
- Remove any foreign debris such as string, wire, branches, etc. that may have wrapped around the flywheel or rear roller, if equipped.
- Inspect motor, bearing adapter (spindle), valves, hydraulic fittings, and hoses for leaks and damage. Replace as needed. Make sure skid loader is shut off and hydraulic pressure is relieved before checking for leaks. Never use hands to check for high pressure hydraulic leaks.

Maintenance (cont.)

- The pressure relief valves are preset and require no maintenance or adjustment. Unauthorized adjustment may cause damage to the motor or change the rate the blades slow to a stop. Please call Virnig Mfg. Inc. with any questions or problems regarding the pressure relief valves.
- If the V50 Rotary Brush Cutter-Standard Deck is still under warranty, contact your dealer before attempting any repairs. **Bearing adapters (spindles) and motors that have been disassembled without prior approval will not be covered under warranty.** Motors and bearing adapters need to be intact for Virnig Mfg. Inc. to get any warranty reimbursement from the component manufacturer. If the component manufacturer declines warranty due to tampering or misuse, Virnig Mfg. Inc. reserves the right to void warranty as well.
- Contact your dealer for any required replacement parts.

*Every 50 hours of operation

- Thoroughly clean (power washing is recommended) both the topside and underside of the brush cutter deck. This will help identify any areas that may be damaged, broken or worn. Repair as necessary.

Blade Replacement Procedure

- Make sure hydraulics are disconnected from machine and deck is properly supported as you will need access to the bottom of the deck. The V50 Rotary Brush Cutter-Standard Deck is very heavy and steps need to be taken to make sure the deck is stable and secure before making any repairs.
- Loosen 1/2" bolts (Item #5) securing blade bolt access cover (Item #15), and swing the cover out of the way. Spin the flywheel until blade bolt appears in access hole. Connecting the cutter's hydraulic couplers together will allow the flywheel to spin more freely.
- Loosen and remove the 1" nut (Item #12) retaining the blade. The square neck on the bolt (Item #7) will prevent the bolt from spinning. When the nut is removed, the blade (Item #16) should drop freely from the flywheel.
- Reinstall new blade and hardware (this step may require additional help) and torque to the specified torque (see "Drive and Blade Assembly"). **(Note: There is a special washer (Item #27) that needs to be installed between the flywheel and nut.)**
- Repeat above steps for the remaining blades.
- Reinstall blade bolt access cover and tighten retaining hardware.

Blade Carrier Removal and Installation

- Make sure hydraulics are disconnected from machine and deck is properly supported as you will need access to the bottom of the deck. The V50 Rotary Brush Cutter-Standard Deck is very heavy and steps need to be taken to make sure the deck is stable and secure before making any repairs. The blade carrier weighs approximately 200 lb. and care needs to be taken when handling.
- From the underside of the deck, remove 6 of the 8 - 5/8" bolts (Item #26) that hold the blade carrier (Item #23) to the bearing adapter (spindle) (Standard Flow-Item #44 or High Flow-Item #63); the 2 bolts left should be opposite each other. **Do not** remove all 8 bolts at this time.
- Support the blade carrier using blocking and remove the last 2 bolts that hold the blade carrier to the bearing adapter (spindle). Blade carrier should fall free of the bearing adapter. The use of a floor jack is recommended to finish removal of the blade carrier.
- To reinstall, the blade carrier should be positioned under the bearing adapter (spindle) so the bolt holes are aligned. Using a jack, lift the blade carrier until it comes in contact with the bearing adapter. Block up blade carrier and remove jack. Install at least 2 bolts opposite each other to hold the flywheel in position. Remove blocking and install the remaining 6 bolts. Tighten and torque (see "Bolt Torque Chart"). It is recommend to use a thread locking compound on the 8 bolts (Item #26) that hold the blade carrier to the bearing adapter.

Blade Tip Speeds

Blade tip speeds at specified flow rates in gallons per minute (gpm).

Blade tip speeds listed in feet per minute.

Standard Flow Models			High Flow Models		
MODEL	14 gpm Minimum	18 gpm Maximum	MODEL	25 gpm Minimum	33 gpm Maximum
RBV60-18	10,367	13,329	RBV60-HF33	11,483	15,157
RBV66-18	11,404	14,662	RBV66-HF33	12,630	16,672
RBV72-18	12,440	15,995	RBV72-HF33	13,779	18,188
RBV78-18	13,477	17,328	RBV78-HF33	14,927	19,704
MODEL	18 gpm Minimum	25 gpm Maximum	MODEL	33 gpm Minimum	42 gpm Maximum
RBV60-25	10,534	14,631	RBV60-HF42	10,062	12,806
RBV66-25	11,588	16,094	RBV66-HF42	11,068	14,087
RBV72-25	12,641	17,557	RBV72-HF42	12,074	15,367
RBV78-25	13,695	19,020	RBV78-HF42	13,081	16,648

Labels on V50 Rotary Brush Cutter-Standard Deck Attachment



7389PP – RBV DANGER HAZARD LABEL

This label has several important instructions for safe operation regarding flying object hazards and cutting hazards.



7388PP – RBV DANGER STAY CLEAR LABEL

All bystanders must stay clear during operation.



7387PP – RBV LIFT LIMIT WARNING LABEL

Lift Limit Chains must be properly installed for safe operation of this attachment. (See additional information in this manual.)

Labels on V50 Rotary Brush Cutter-Standard Deck Attachment (cont.)

 WARNING
<ul style="list-style-type: none">• NEVER use hands to check for oil leaks.• ALWAYS relieve pressure before disconnecting hoses.• ALWAYS disconnect hoses before performing any maintenance on rotary cutter.• Attachment must be securely latched to loader.• Before leaving operator's seat, lower lift arms to stops, place cutter flat on the ground, disengage hydraulics, stop engine, engage parking brake and make sure all rotation has stopped.• Inspect blades before each use, replace damaged blades. Blades CAN NOT be straightened or welded.• Check for other loose or broken parts before operating, repair as needed.• Avoid stalling rotary cutter. Continued stalling will overheat the hydraulic system.• ALWAYS follow loader safety and operating instructions.• Stay back 200 feet during operation.• See additional safety and operational instructions in Owner's Manual.• Read and understand all operating and safety instructions in Owner's Manual.• Failure to follow these instructions could result in injury or death. 7386PP

7386PP – RBV MAIN WARNING LABEL

This label has several important instructions that must be followed for safe operation of this attachment.

18 GPM MAX

7489PP – 18 GPM MAX LABEL

or **25 GPM MAX**

7490PP – 25 GPM MAX LABEL

or **33 GPM MAX**

7794PP – 33 GPM MAX LABEL

or **42 GPM MAX**

7795PP – 42 GPM MAX LABEL

This label indicates the maximum flow rate for this attachment.

V50 Rotary Brush Cutter-Standard Deck (RBV) Label Parts List

ITEM	PART NO.	QTY	DESCRIPTON
1	7386PP	2	RBV MAIN WARNING LABEL
2	7387PP	2	RBV LIFT LIMIT WARNING LABEL
3	7388PP	3	RBV DANGER STAY CLEAR LABEL
4	7389PP	3	RBV DANGER HAZARD LABEL
5*	7489PP	1	18 GPM MAX LABEL
	7490PP		25 GPM MAX LABEL
	7794PP		33 GPM MAX LABEL
	7795PP		42 GPM MAX LABEL
6*	9392PP	1	60 WIDTH LABEL
	9394PP		66 WIDTH LABEL
	9397PP		72 WIDTH LABEL
	9398PP		78 WIDTH LABEL
7	SERIALTAG	1	SERIAL NUMBER TAG

*Based on V50 Rotary Brush Cutter-Standard Deck configuration.

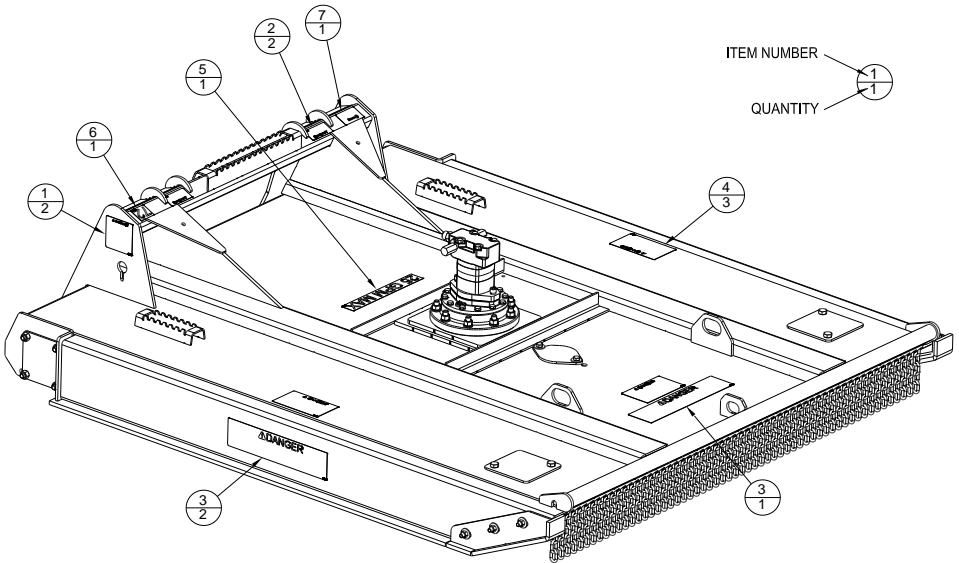

V50 Rotary Brush Cutter-Standard Deck (RBV) Parts List

ITEM	PART NO.	QTY	DESCRIPTION	
	1	1003PP	8	1/2"-13 REVERSE LOCK NUT
	2	1008PP	30	5/8"-11 TOP LOCK NUT
	3	1083PP	2	3/8" USS FLAT WASHER
	4	5148PP	10	1/2" USS FLAT WASHER
	5	5226PP	10	1/2"-13 X 1 1/2" LG HHCS
	6	6140PP	2	3/8"-16 TOP LOCK FLANGE NUT
	7	7249PP	3	BRUSH CUTTER BLADE BOLT
	8	7273VW	1	FRONT SKID WELDMENT LH
	9	7276VW	1	FRONT SKID WELDMENT RH
A	10	7327PP	--	5/16" X 5 LINK CHAIN GRADE 30
	11	7328PP	2	3/8" X 42" LG CHAIN GRADE 80
	12	7330PP	3	1"-14 TOP LOCK
	13	7335PP	2	3/8"-16 X 1 1/2" LG HHCS
A	14	-----	1	CHAIN GUARD SUPPORT ROD
	15	7337VP	1	BLADE BOLT ACCESS COVER
A	16	-----	3	BRUSH CUTTER BLADE
	17	7440VP	2	BRUSH CUTTER ROLLER CAP PLATE
	18	7479VP	2	LIFT LIMIT RETAINER PLATE
	19	9718PP	9	5/8"-11 X 3 1/2" LG HHCS
	20	7778PP	12	5/8"-11 X 1 1/2" LG HHCS
	21	7790PP	3	5/8"-11 X 2" LG CB
	22	8711PP	9	5/8" LOCK WASHER
A	23	-----	1	BLADE CARRIER ASSEMBLY
	24	8699VP	2	BRUSH CUTTER CASTER COVER
A	25	-----	1	RBV DECK WELDMENT
	26	9051PP	8	5/8"-11 X 2" LG HHCS GR8
	27	9340PP	3	1" DIAMETER NORD-LOCK WASHER
	28	9837VW	1	BRUSH CUTTER SPINDLE GUARD WDT

A - See Table 1.

Table 1

MODEL	RBV60	RBV66	RBV72	RBV78
RBV DECK WELDMENT	8703VW	8706VW	8701VW	8709VW
BLADE CARRIER ASSEMBLY	8715VA	8568VA	8568VA	8568VA
NO. OF CHAINS	48	51	57	60
CHAIN GUARD SUPPORT ROD	7435VP	7385VP	7336VP	7419VP
BRUSH CUTTER BLADE	7340PP	7340PP	7341PP	7342PP
B BLADE REPLACEMENT KIT	CBK60	CBK66	CBK72	CBK78

B - Blade kits contain 3 each of blade, bolt, washer, and nut.

Bolt Torque Chart

SIZE	GRADE 5		GRADE 8		SHCS*	
	COARSE	FINE	COARSE	FINE	COARSE	FINE
1/4"	6	7	9	10	10	12
5/16"	13	15	18	20	22	24
3/8"	23	26	33	37	38	43
7/16"	37	41	52	58	61	68
1/2"	57	64	80	90	93	105
9/16"	82	91	115	128	134	150
5/8"	113	128	159	180	179	202
3/4"	200	223	282	315	317	354

*SHCS—Socket Head Cap Screw

Values are in ft.-lb. and are recommended unless otherwise noted.

Access Cover Assembly

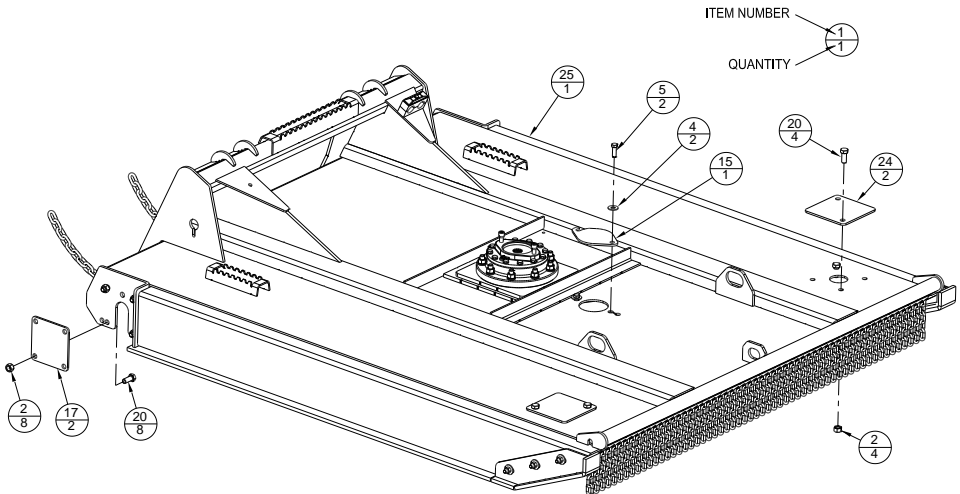

Skid Shoe and Chain Assembly

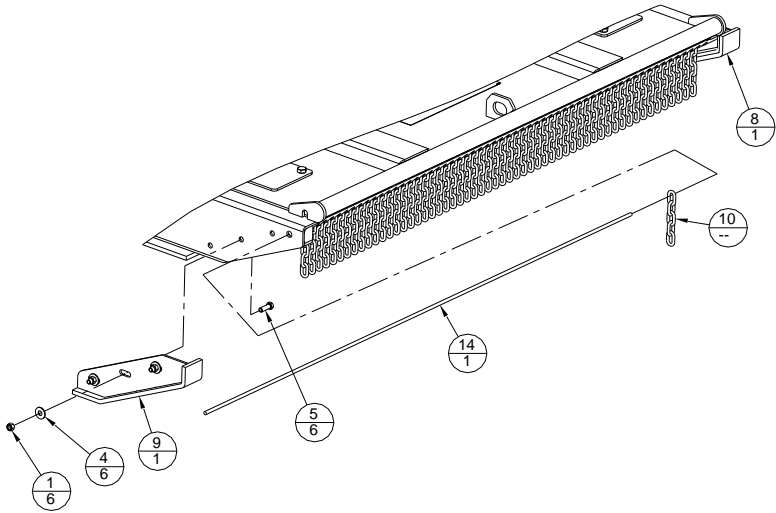

Lift Limit Chain Assembly

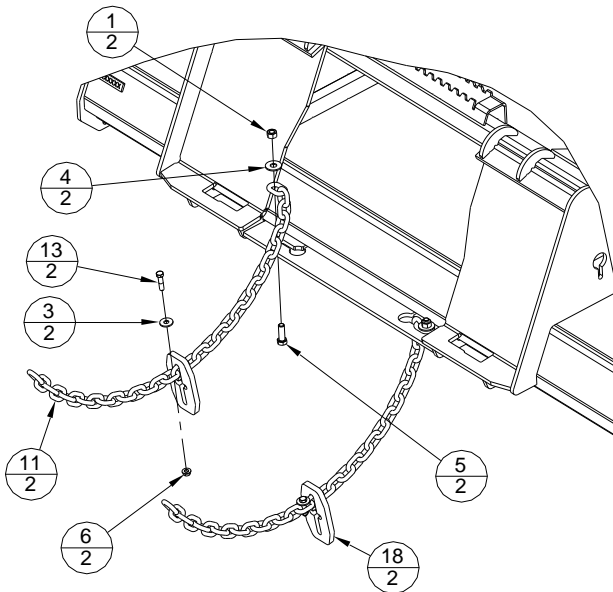

Drive and Blade Assembly

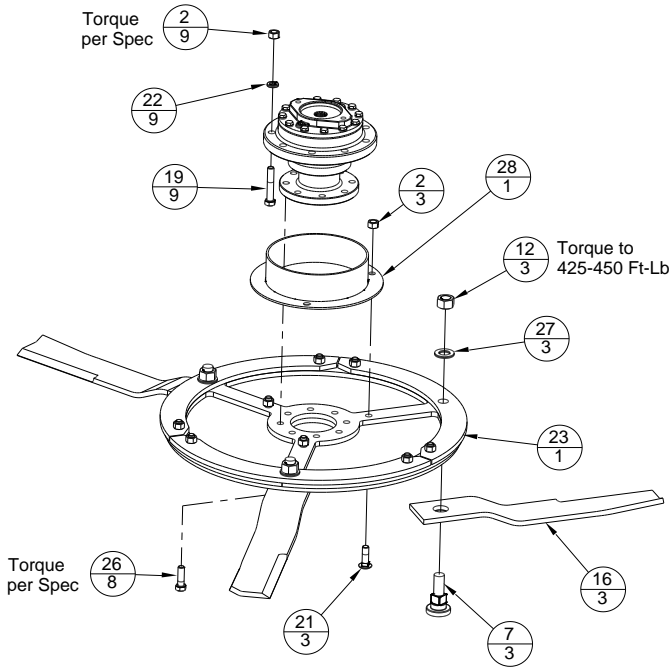

Note: Apply a thread locking compound to Item #26 prior to assembly.

Blade Carrier Assembly

ITEM	PART NO.	QTY	DESCRIPTION
29	8569VP	1	LOWER BLADE CARRIER PLATE
	8716VP		60" LOWER BLADE CARRIER PLATE
30	8570VP	1	MIDDLE BLADE CARRIER PLATE
	8717VP		60" MIDDLE BLADE CARRIER PLATE
31	7285VP	3	UPPER BLADE CARRIER PLATE
	7439VP		60" UPPER BLADE CARRIER PLATE
32	7334PP	6	5/8"-11 X 2 1/4" LG CB

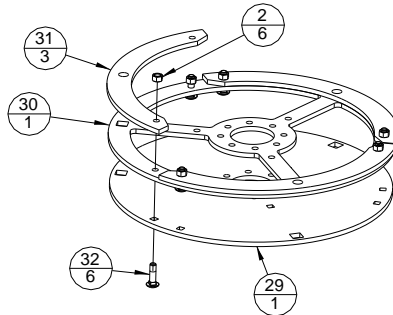

Standard Flow Hydraulic Component Assembly

ITEM	PART NO.	QTY	DESCRIPTION
33	10684PP	1	5/16"-18 X 3 1/4" LG HHCS
34	6719PP	2	1/2" -13 X 1 1/2" LG SHCS
35	6734PP	1	COUPLER FEMALE 12FB
36	6735PP	1	COUPLER MALE 12FB
37	9028PP	2	ADAPTER 12MJ TO 10 MB
38	7672PP	1	5/16"-18 TOP LOCK FLANGE NUT
39	11020PP	2	HYD HOSE 3/4" X 120" LG 12FJX TO 12MB
40	7780PP	1	GASKET STANDARD FLOW MOTORS
41	7782PP	1	MOTOR STANDARD FLOW 14-18 GPM
	7783PP		MOTOR STANDARD FLOW 18-25 GPM
42	8697PP	1	HOSE CLAMP ASSEMBLY 3/4" HOSE
43	6720PP	2	1/2" HI-COLLAR LOCK WASHER
44	10568PP	1	RBV SPINDLE STANDARD FLOW ESKRIDGE

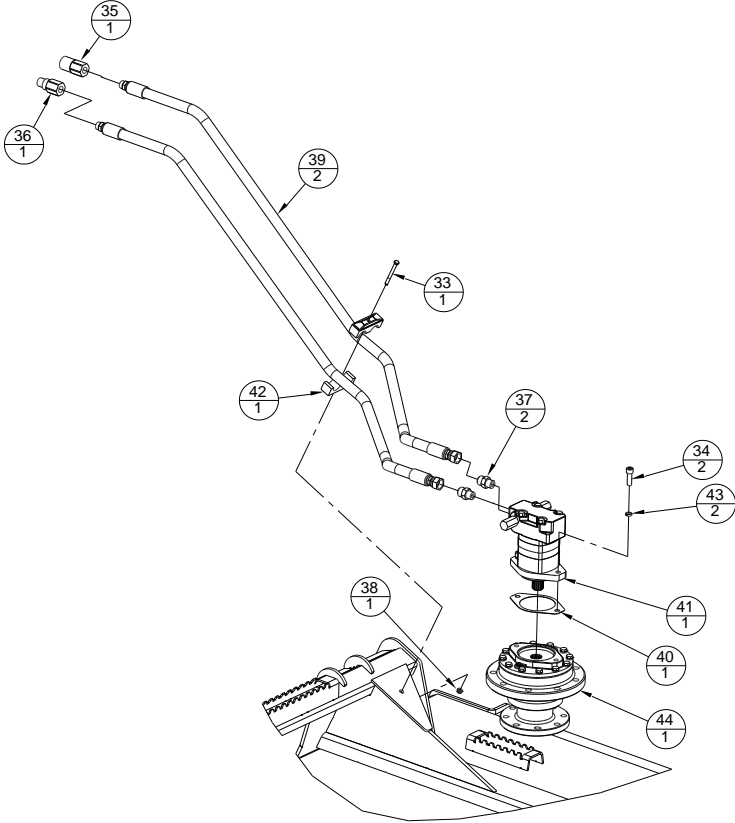

Standard Flow Bearing Adapter (spindle) oil capacity is 14 fluid ounces.

High Flow Hydraulic Component Assembly

ITEM	PART NO.	QTY	DESCRIPTION	
	45	10384PP	1	MANIFOLD CROSS PORT RELIEF
	46	10557VP	1	IRC MANIFOLD GUARD LOWER
	47	10559VW	1	IRC MANIFOLD GUARD WELDMENT
	48	10560PP	3	3/8"-16 X 6" LG HHCS
	49	6140PP	3	3/8"-16 TOP LOCK FLANGE NUT
	50	10561PP	4	3/18-16 X 4 1/4" LG SHCS
	51	10562PP	4	3/8" HIGH COLLAR LOCK WASHER
C	52	7796PP	1	ADAPTER 6MJ TO 6MB
		1145PP		ADAPTER 6MJ TO 8MB
D	53	10236PP	1	O-RING HIGH FLOW C MOUNT
	54	7784PP	1	MOTOR HIGH FLOW 25-33 GPM
		7785PP		MOTOR HIGH FLOW 33-42 GPM
	55	8866PP	4	1/2" -13 X 1 3/4" LG HHCS GR8
	56	8712PP	4	1/2" LOCK WASHER HIGH ALLOY
E	57	6734PP	1	COUPLER FEMALE 12FB
		7978PP		COUPLER FEMALE 12FB 5/8" BODY
		10766PP		COUPLER FEMALE 12FB 3/4" BODY
E	58	6735PP	1	COUPLER MALE 12FB
		7979PP		COUPLER MALE 12FB 5/8" BODY
		10767PP		COUPLER MALE 12FB 3/4" BODY
E	59	7982PP	1	COUPLER FEMALE CASE DRAIN 3/8"
		7983PP		COUPLER MALE CASE DRAIN 3/8"
		9448PP		MALE COUPLER CASE DRAIN 1/4"
		9449PP		FEMALE COUPLER CASE DRAIN 1/4"
	60	7984PP	1	ADAPTER 6MJ TO 4MB
	61	7986PP	1	HYD HOSE 3/8" X 120" LG 6FJX TO 6FJX
	62	8990PP	2	ADAPTER 12MJ TO 16MB
	63	10569PP	1	RBV SPINDLE HIGH FLOW ESKRIDGE
	64	9447PP	2	HYD HOSE 3/4" X 118" LG 4000 PSI 12MB TO 12FJX

C - 7796PP used with 1/4" Case Drain Couplers (9448PP or 9449PP).

D - 1145PP used with 3/8" Case Drain Couplers (7982PP or 7983PP).

E - Supplied with one of each depending on machine.

High Flow Hydraulic Component Assembly (cont.)

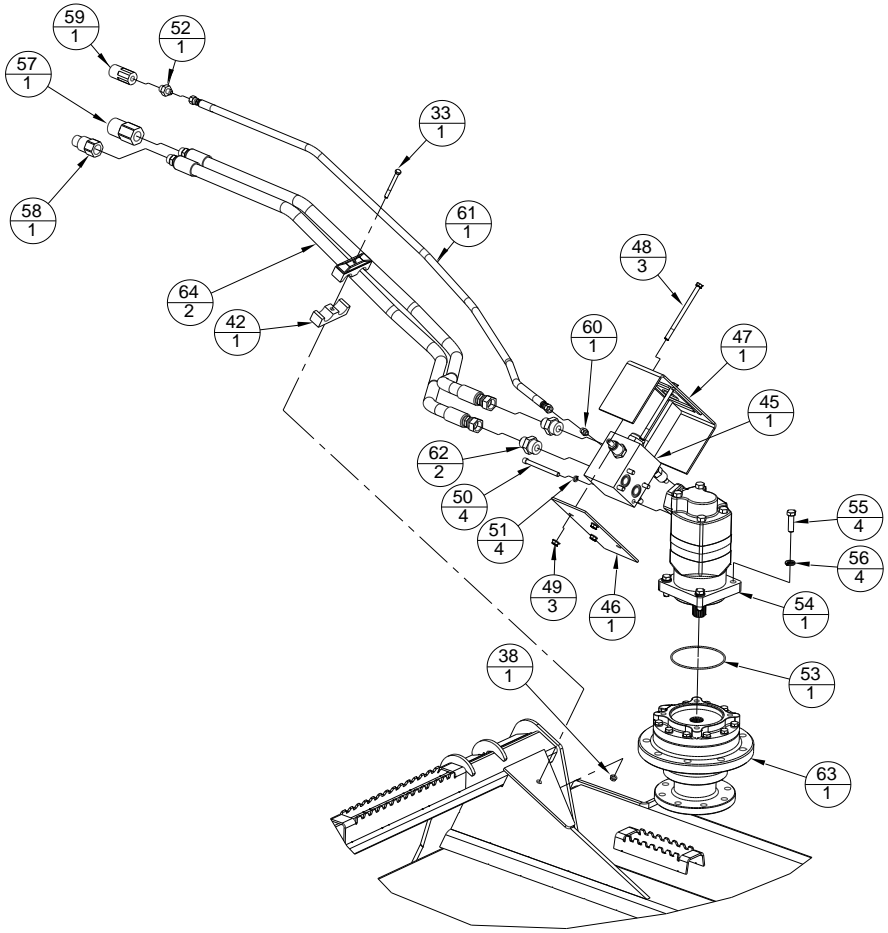

High Flow Bearing Adapter (spindle) oil capacity is 14 fluid ounces.

Optional Roller Assembly (BCR)

ITEM	PART NO.	QTY	DESCRIPTION
1	1008PP	8	5/8"-11 TOP LOCK NUT
2	7431WW	1	60" BRUSH CUTTER ROLLER WDT
	7381WW		66" BRUSH CUTTER ROLLER WDT
	7277WW		72" BRUSH CUTTER ROLLER WDT
	7415WW		78" BRUSH CUTTER ROLLER WDT
3	7719PP	8	5/8"-11 X2" LG HHCS
4	7773PP	2	2" BEARING W/4 HOLE FLANGE
5	7957PP	8	5/8" SAE FLAT WASHER

Optional Roller Assembly Item Numbers

MODEL	RBV60	RBV66	RBV72	RBV78
OPTIONAL REAR ROLLER KIT	BCR60	BCR66	BCR72	BCR78

Optional Rear Roller Kit contains roller, 2 bearings and mounting hardware.

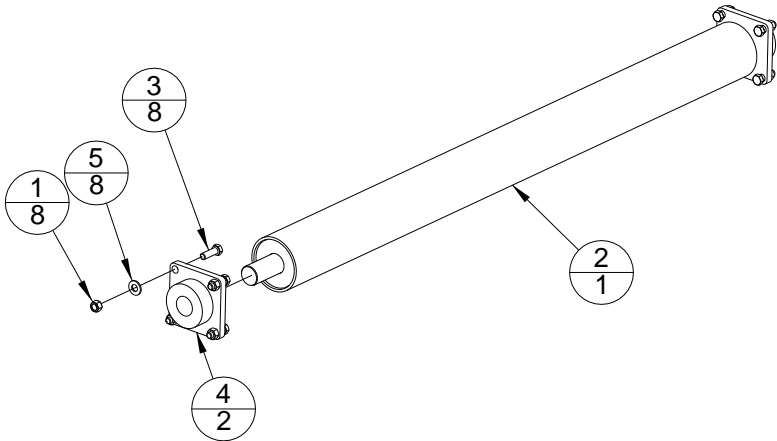

Optional Front Caster Assembly (BCC)

ITEM	PART NO.	QTY	DESCRIPTION
1	1005PP	2	7/16"-14 REVERSE LOCK NUT
2	1008PP	8	5/8"-11 TOP LOCK NUT
3	1034PP	2	1/4"-28 STRAIGHT GREASE ZERK
4	1046PP	2	7/16"-14 X 2 3/4" LG HHCS
5	1094PP	4	1 1/4" X 10GA MACH BUSHING
6	1111PP	4	1 1/4" DIA X 1 9/16" LG BUSH
7	11384VW	2	CASTER SWIVEL WELDMNT W/WHEEL
8	7719PP	8	5/8"-11 X 2" LG HHCS
9	8724VW	2	CASTER WHEEL LOWER MOUNT WDT
10	8725VP	2	CASTER WHEEL COLLAR PLATE

Quantities listed above are for a pair (Quantity 2) of casters.

Optional Front Caster Assembly can be ordered under Item Number BCC.

