

# POWER RAKE

AVAILABLE  
SPRING 2016

LANDSCAPING

- 1 Direct drive Eaton® motor reduces downtime, and is guarded from damage.
- 2 Floating design keeps the rake level for a smooth, even finish.

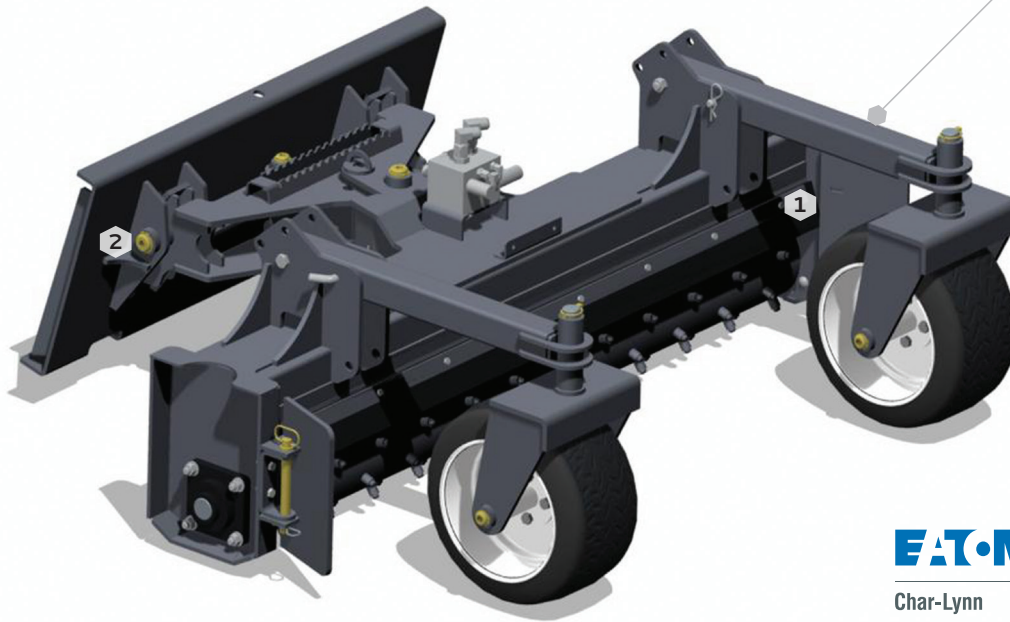

**EAT•N**  
Char-Lynn

## FEATURES

- Grade, rake, level and remove debris all with one attachment.
- Bi-directional drum works the soil in both directions for quick seedbed preparation.
- Manually angle the rake 25 degrees in either direction, Hydraulic Angle option available.
- Standard carbide tip teeth for long life in many soil conditions.
- Standard removable end plates help contain raked debris.
- Solid urethane filled tires eliminate costly interruptions from flats.

## OPTIONS

### Hydraulic Angle

- Allows the operator to quickly angle the rake 25 degrees in either direction to windrow debris.

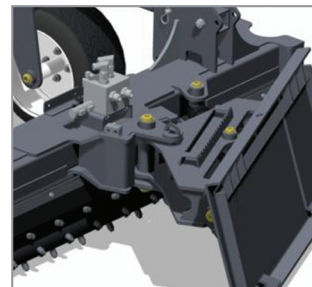

# POWER RAKE SPECS

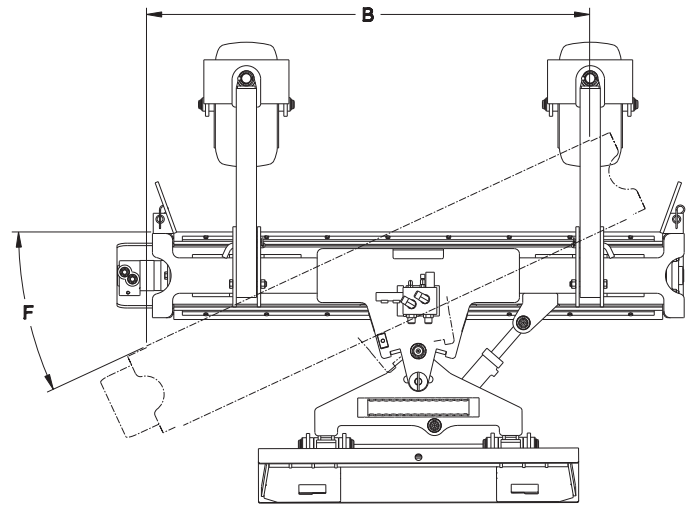
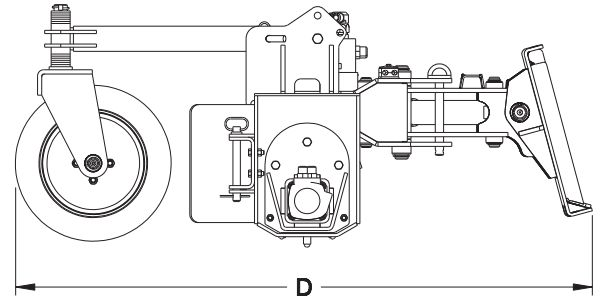
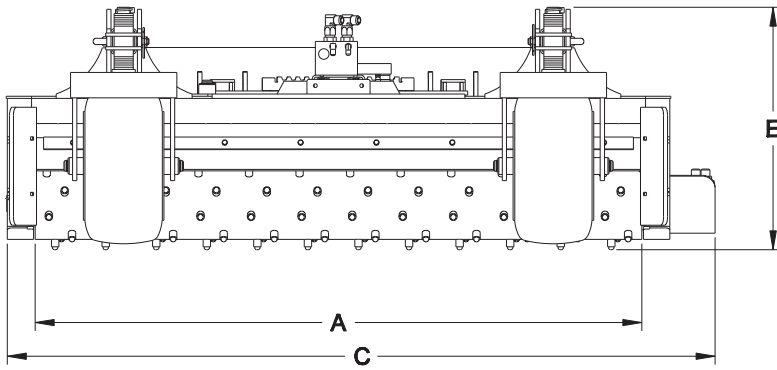

MODEL	PWR72	PWR90
(A) Raking Width (Inches)	72.0	90.0
(B) Raking Width at Full Angle (Inches)	65.3	81.5
(C) Overall Width (Inches)	84.0	102.0
(D) Overall Depth (Inches)	68.5	
(E) Overall Height (Inches)	27.5	
Drum Diameter (Inches)	8.5	
Number of Teeth	119	149
Float Link Angle (Degrees)	22	
(F) Rake Angle (Degrees)	+/- 25	
Approximate Weight (Pounds)	1335	1440
Recommended Loader Capacity	Greater than 1500 pounds	

• Price includes fittings, Eaton® hoses, and couplers.