

Pick-Up Broom (Includes Optional Gutter Brush)

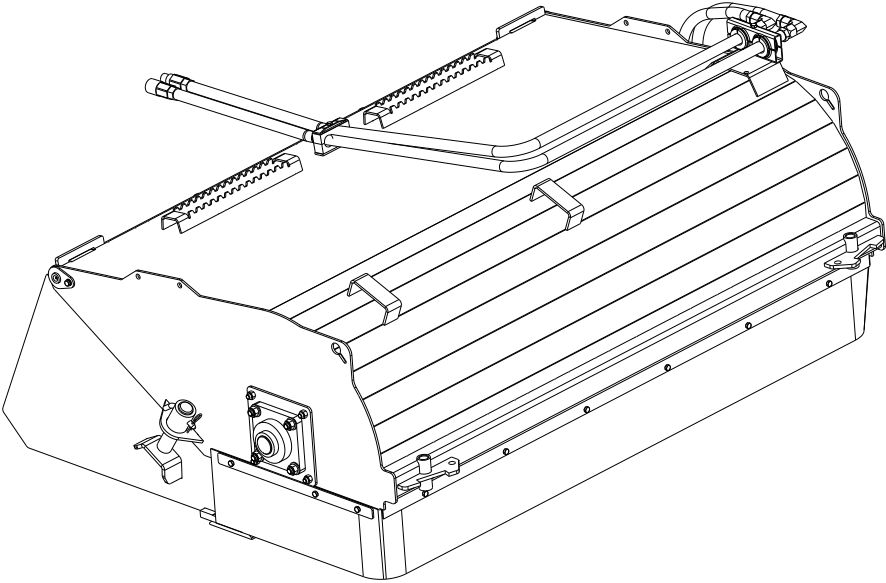

Model Number _____ **PUB** _____.

Serial Number _____.

Serial Number 106596 - 107650
Manufacture Date 05/05/15 – 07/01/15

Phone: 320-393-7080

2/29/12
Revised 05/05/15

PUB

Features of Virnig Mfg. Inc. Pick-Up Broom include:

- Pick-Up Broom can operate in both forward and reverse.
- Equipped with a standard 5/8" x 6" bolt on reversible wear edge.
- Adjustable hood easily adjusts to compensate for wear of wafers.
- 15-25 gpm operating flow rate range and 2000 – 3500 psi operating pressure range.
- Easy exchange of wafers, do not have to disconnect hydraulic lines to change wafer sections.
- Standard wafer package is a 26" diameter poly/wire combination.
- Direct drive design with replaceable drive components.
- Optional Gutter Brush and Water Kit are available.
- Recommended for loaders with an operating capacity greater than 1500 lb.

Initial Use

- Read and understand all warning information in this manual before operating this attachment.
- Check that quick-tach on frame fits onto loader properly. Pins must engage through 3/8" plates at bottom of quick-tach.
- Slowly roll back attachment. Make sure there is no interference between attachment and loader.
- Connect lead hoses to standard flow hydraulics. Do not connect this attachment to high flow hydraulics.
- Make sure hoses do not pinch during roll back.
- Slowly roll bucket fully forward. Check that hoses are long enough so they do not stretch or bind.
- Never exceed the maximum attachment operating pressure of 3500 psi.
- With the Pick-Up Broom off of the ground, engage the auxiliary hydraulics using the "detent" position on the machine. Check the rotation of the broom (broom should be sweeping away from the machine or clockwise when looking from the motor end.) If this rotation does not match the "detent" position of your machine, switch the couplers on the lead hoses.
- There are 2 hose clamp locations provided to secure the lead hoses if needed. It is recommended that the left side clamp, located on the back of the bucket, be used for Terex, ASV, Bobcat, Kubota and Caterpillar machines and the center clamp, located on the hood, be used for all other makes.
- Do not store Pick-Up Broom with weight on the wafers as this may deform the bristles reducing the sweeping efficiency.

Adjusting the Brush Pattern

- No initial adjustment of the brush pattern should be required. Periodic adjustment of the Pick-Up Broom head will ensure longer wafer life and more efficient operation.
- Check the brush pattern of the Pick-Up Broom by starting the broom rotating, lowering the boom arms of the machine to the stops and rolling the bucket forward until the cutting edge is approximately ½"-1" off of the ground. Run the broom for about 10 seconds and lift the broom up and back away. For a correctly adjusted broom, there should be a clean strip about 2-4" wide where the brush was sweeping. If not, an adjustment needs to be made.
- If the pattern is less than 2-4", the broom head needs to be lowered. To do this, prop up the front of the broom to take the weight off of the adjustment shafts (Item #29, see Figure 2). Remove the bent leg pin (Item #30) and move the adjustment shaft to the next lower hole location. Reinstall the bent leg pin. Repeat procedure on other side of the Pick-Up Broom.
- Make sure both sides are evenly adjusted to ensure consistent wear across the width of the broom.

Operation

- Always follow safety and operating information in this manual.
- Always follow all safety and operating instructions of the loader.
- Never remove material deflectors or warning labels.
- Never operate Pick-Up Broom unless you have been properly trained.
- Make sure all safety labels are in place, look in this manual for their locations.
- Do not sweep toward people, buildings, etc. that may be injured or damaged by flying debris.
- Always relieve pressure before connecting or disconnecting hydraulic hoses.
- Clean any debris from attachment. Pay special attention to any debris in quick-tach area.
- The Pick-Up Broom is designed to be operated driving in the forward direction so that the brush sweeps debris away from the operator (brush spins clockwise when looking from the motor end). The brush will spin in the opposite direction and should be when sweeping and travelling backward.
- Do not change the rotation direction of the broom without allowing the broom to come to a complete stop. Doing so may cause premature failure of components.

Sweeping Recommendations

- Sweep with the wind whenever possible to provide more efficient operation and keep debris off of the operator.
- When driving forward, sweep in such a manner that the material being swept goes up and over the wafers and into the bucket (broom should be rotating clockwise looking from the motor end). This should be the “detent” position on the machines controls.
- When driving in reverse, sweep in such a manner that the material goes directly into the bucket (broom should be rotating counterclockwise looking from the motor end).
- When sweeping on rough terrain, reduce machine ground speed to minimize “bouncing” of broom head.
- The cutting edge of the bucket should be approximately ½”-1” off of the ground during normal operation.
- Avoid excessive weight on the broom wafers. Brooms sweep with the tips of the wafers; therefore, the sweeping contact pattern should be about 2”-4”. Unnecessary weight promotes excessive wear and premature failure of wafers. Ensure the adjustment shafts are adjusted equally to provide consistent wafer wear.

Maintenance

*Before each use and after every 10 hours of operation

- Grease hinge pins and bearing (3 fittings on Pick-Up Broom, 1 additional fitting if equipped with optional Gutter Brush).
- Check for wear on wafers. If the outside diameter of the wafers is one half of the original diameter, the wafers need to be replaced. The original diameter of the wafers for the Pick-Up Broom is 26”.
- Make sure all safety labels are in place, look in this manual for locations.
- Check for loose, worn, or missing parts, repair or replace as needed.
- Remove any foreign debris such as string, wire, etc. that may have wrapped around the brush head.
- Inspect motor, valve, hydraulic fittings, and hoses for leaks and damage. Replace as needed. Make sure machine is shut off and hydraulic pressure is relieved before checking for leaks. Never use hands to check for high pressure hydraulic leaks.
- The pressure relief valves require no maintenance. The valves are pre-set and require no adjustment. Changing settings may cause damage to the motor. Please call Virnig Mfg. Inc. with any questions or problems regarding the pressure relief valves.
- Contact your dealer for any required replacement parts.

Brush Replacement Procedure

- Remove the Rubber Flap (Item #22, see Figure 2) from the sides of the Pick-Up Broom Hood by removing the Rubber Retaining Strips (Item #17) from both sides by removing the 3/8" nut (Item #7) from the 3/8" x 1" bolt (Item #11).
- Remove the 4 nuts (Item #1, see Figure 5) holding the Hydraulic Motor Assembly and remove the Hydraulic Motor Assembly.
- Remove the 4 nuts (Item #1, see Figure 4) holding the Broom Shaft Assembly and remove the Pick-Up Broom Shaft Assembly.
- The core should be free from the brush head. Lift brush head and remove to expose core.
- Remove the retaining plate (either Item #34 or Item #35) from one end of the core (see Figure 4).
- Remove old brush sections. Inspect drive bars for indentations or excessive wear. Replace core cage if damage is evident.
- Stand core on end with retaining plate still attached and install the new brush sections making sure the drive pins of the wafer engage one of the core drive bars. For a snug fit, install consecutive wafers so that the drive pins are 180° apart. Start with a poly wafer and alternate between poly and wire wafers until core is full. The last wafer should be poly also.
- Reinstall the retaining plate and lay core on ground. When handling the core, do not use the wafers to move the core.
- Lower brush head over core with new brush sections.
- Reinstall Pick-Up Broom Shaft Assembly into core and secure with nuts.
- Before reinstalling motor, remove the 3/8" bolt (Item #38, see Figure 5) holding the Drive Adapter (Item #41) on the Hydraulic Motor (Item #40) and apply a thin layer of grease to the splines of the motor. Reinstall Drive Adapter to the Hydraulic Motor.
- Reinstall Hydraulic Motor Assembly and secure with nuts.
- Reinstall the Rubber Flap and Retaining Strips on both sides of the Pick-Up Broom Hood.

Optional Gutter Brush Operation

- The Gutter Brush is equipped with a variable speed valve. This allows the operator to adjust the speed of the gutter brush based on the material being swept as well as turn the Gutter Brush off if not in use. Slower speeds are recommended for heavier, denser materials, while faster speeds may be better for lighter materials.
- Use the adjustment chain provided to adjust the height of the Gutter Brush to contact the ground when the Pick-Up Broom is in the correct sweeping position.
- The Gutter Brush is to be used only when sweeping with the Pick-Up Broom moving in the forward direction. The Gutter Brush will not function if the broom is rotating in the counterclockwise (backward) direction when looking from the broom motor end of the Pick-Up Broom.
- The Gutter Brush provides an additional 12" of sweeping width and is useful when sweeping along curbs or buildings. Only the bristle tips of the gutter brush should touch the vertical surface of the curb or wall.
- If the Gutter Brush is not going to be used for a short period of time, shut the variable speed valve off and lift the brush 2-4" off of the ground using the adjustment chain.
- If the Gutter Brush is not going to be used for long periods of time, shut the variable speed valve off and secure the brush in its storage position using the adjustment chain. It is not recommended to remove the Gutter Brush from the Pick-Up Broom when not in use.

Field Installation of Optional Gutter Brush

- The Gutter Brush can be installed on either the right or left hand side of the Pick Up Broom. Care needs to be taken when connecting the Gutter Brush hydraulic lines to the valve block.
- Make sure machine is shut off and hydraulic pressure has been relieved.
- Disconnect hydraulic lines from the machine if not already done.
- Remove 3/8" nut (Item #7) and bolt (Item #9) holding the hose clamp (Item #8) on left hand side (as seated in machine) of broom and remove hose clamp (see Figure 3). These items will not be used for the Gutter Brush installation.
- Install valve block (Item #30, see Figure 6) on valve mounting bracket (same bracket the hose clamp was removed from in previous step) with hardware provided (Items #12, #13 and #31).
- Install Gutter Brush on desired side of Pick-Up Broom using the 7/8" hitch pin provided (Item #16, see Figure 7). Secure Gutter Brush with adjustment chain provided.

Field Installation of Optional Gutter Brush (cont.)

- Remove 90° elbows (Item #21, See Figure 3) connecting the lead hoses (Item #20) to the motor hoses (Item #19). Take note of which lead hose and coupler connects with which motor hose. These elbows will no longer be used. To minimize loss of hydraulic oil, lay coupler ends of hoses on the ground and hold elbows over drain pan when disconnecting.
- Connect the lower motor hose (see Figure 3) to port “M1” on the valve block and the upper motor hose to port “M2”.
- Remove the case drain plug on the Pick-Up Broom hydraulic motor (located on the opposite side of the motor from the hose ports) and install the small straight adapter and 90° swivel elbow (Items #33 and #24, see Figure 6) and connect the case drain hose (Item #14) that is attached to the valve block. Secure case drain hose to motor hoses with zip ties (not shown).
- Connect the lead hose that was connected to the lower motor hose to port “P1” on the valve block and the lead hose that was connected to the upper motor hose to port “P2” on the valve block.
- If the Gutter Brush is mounted on the right side of the Pick-Up Broom, route the hoses through the hose guides and connect Gutter Brush hose “A” (see Figure 7) to port “M3” on valve block and Gutter Brush hose “B” to port “M4”.
- If the Gutter Brush is mounted on the left side of the Pick-Up Broom, route the hoses through the center hose guide and connect Gutter Brush hose “A” (see Figure 7) to port “M4” on the valve block and Gutter Brush hose “B” to port “M3”.
- After all hose connections have been tightened, connect the broom hydraulics to the loader and test run. With the Pick-Up Broom spinning in the clockwise direction when looking from the motor end, the Gutter Brush should be spinning such that it would be throwing material in front of the Pick-Up Broom. You may have to turn the control knob on top of the valve out if the Gutter Brush is not spinning.
- If the Gutter Brush does not spin with the Pick-Up Broom spinning in the clockwise direction, then the gutter brush hoses probably need to be switched. To verify this, run the broom in the reverse direction, if the gutter brush spins, the gutter brush hoses need to be switched.
- Call Virnig Manufacturing at 1-800-648-2408 with any installation questions.

Warning Labels on Pick-Up Broom Attachment

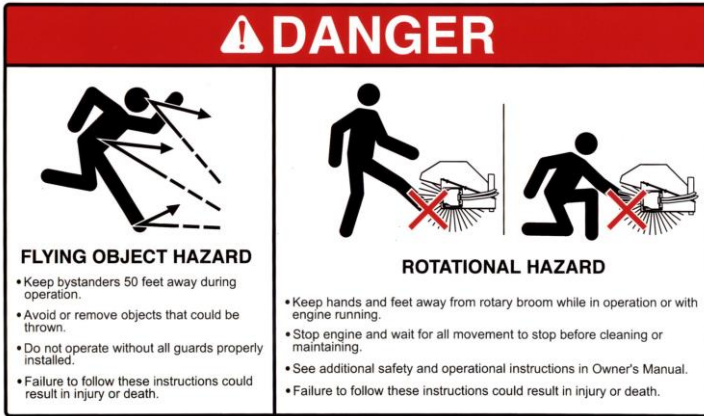

This label is located on the front and sides of the hood.

This label has several important instructions for safe operation regarding flying object hazards and rotational hazards.

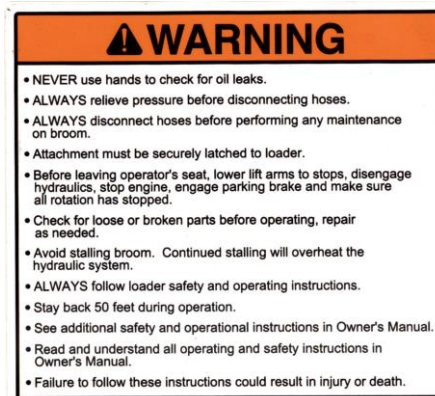

This label is located on side of hood and on the back of the bucket near the quick-tach.

All bystanders must stay clear during operation.

This label has several important instructions that must be followed for safe operation of this attachment.

Warning Labels on Pick-Up Broom Attachment (cont.)



This label is located on the front of the hood weldment on each side of the attachment.

This label has several important instructions that must be followed for safe operation of this attachment.



This label is located on the side of the bucket near the pivot locations.

Always keep hands clear of pivot locations when loader hydraulic system is operational.

25 GPM MAX

This label is located on the hood facing the operator.

This label indicates the maximum flow rate for this attachment.

Pick-Up Broom (PUB) Parts List

ITEM	PART NO.	QTY	DESCRIPTION	
	1	1003PP	18	1/2"-13 REVERSE LOCK NUT
A	2	1008PP	--	5/8"-11 TOP LOCK NUT
	3	1034PP	2	1/4"-28 STRAIGHT GREASE ZERK
A	4	1036PP	--	5/8"-11 X 2" LG PLOW BOLT
	5	1075PP	3	3/8" LOCK WASHER
A	6	-----	1	BOLT ON EDGE 5/8" X 6"
	7	6140PP	25	3/8"-16 TOP LOCK FLANGE NUT
	8	7726PP	1	3/4" HOSE CLAMP ASSY STANDARD
	9	7729PP	1	3/8"-16 X 4 1/2" LG HHCS
	10	7810VW	2	DMP ROD END PIN WELDMENT
	11	7849PP	24	3/8"-16 X 1" LG HHCS
	12	7850PP	2	3/8"-16 X 1 1/4" LG HHCS
	13	7964PP	8	1/2"-13 X 1 1/4" LG CB
	14	7965PP	8	1/2" PUSHNUT BOLT RETAINER
A	15	-----	1	PICK-UP BROOM BUCKET WELDMENT
A	16	-----	1	PICK-UP BROOM HOOD WELDMENT
	17	8455VP	2	RUBBER RETAINING STRIP SIDE
	18	8456VP	2	RUBBER RETAINING STRIP FRONT
	19	8457PP	2	HYD HOSE 3/4" X 32" LG 10MB TO 12FJX
	20	8458PP	2	HYD HOSE 3/4" X 130" LG 12MB TO 12FJX
	21	8460PP	2	ELBOW 90 12MJ TO 12MJ
A	22	-----	1	PICK-UP BROOM RUBBER FLAP
	23	8697PP	1	CLAMP HOSE ASSEMBLY 3/4" HOSE
A	24	-----	1	PICK-UP BROOM REAR SEAL
	25	6734PP	1	COUPLER FEMALE 12FB
	26	6735PP	1	COUPLER MALE 12FB
	27	8736PP	1	5/16"-18 X 2 1/2" LG HHCS
A	28	8865PP	--	5/16" RETAINER PICK UP BROOM
	29	8870VP	2	PICK-UP BROOM ADJUSTMENT SHAFT
	30	8873PP	2	1/2" X 3" LG BENT PIN W/CLIP
	31	5226PP	8	1/2"-13 X 1 1/2" LG HHCS
	32	7931VW	2	ANGLE BROOM ADAPTER FLANGE WDT
A	33	-----	1	PICK-UP BROOM CORE WELDMENT
	34	8398VP	1	PICK-UP BROOM CAP MOTOR END
	35	8399VW	1	PUB CORE CAP WELDMENT
A	36	8478PP	--	WAFER 26 POLY
A	37	8479PP	--	WAFER 26 STEEL
	38	6970PP	1	3/8"-16 X 3 1/2" LG HHCS
	39	5225PP	2	1/2"-13 X 1 3/4" LG HHCS
	40	9437PP	1	MOTOR ANGLE BROOM

Pick-Up Broom (PUB) Parts List (cont.)

ITEM	PART NO.	QTY	DESCRIPTION
41	7908VW	1	HYD MOTOR DRIVE ADAPTER WDT
42	8427VW	1	BROOM HYDRAULIC MOTOR MNT WDT
43	8509PP	1	BROOM MOTOR RUBBER SEAL
44	8510VP	1	BROOM MOTOR SEAL RETAINER
45	7719PP	4	5/8"-11 X 2" LG HHCS
46	7773PP	1	2" BEARING W/4 HOLE FLANGE
47	7916VP	1	VAB BEARING MOUNT PLATE
48	7917VP	1	ANGLE BROOM SHAFT
49	7957PP	4	5/8" SAE FLAT WASHER

A - See Table 1

Table 1

MODEL	PUB60	PUB72	PUB84
BOLT ON EDGE 5/8" X 6"	8874VP	1192VP	1409VP
5/8"-11 TOP LOCK NUT	14	16	18
5/8"-11 X 2" LG PLOW BOLT	10	12	14
PICK-UP BROOM BUCKET WELDMENT	8738VW	8375VW	8753VW
PICK-UP BROOM HOOD WELDMENT	8741VW	8380VW	8756VW
PICK-UP BROOM RUBBER FLAP	8750PP	8467PP	8765PP
PICK-UP BROOM REAR SEAL	8751PP	8733PP	8766PP
PICK-UP BROOM 5/16" RETAINER	8	10	12
PICK-UP BROOM CORE WELDMENT	8747VW	8391VW	8762VW
NUMBER OF POLY WAFERS	15	18	21
NUMBER OF STEEL WAFERS	14	17	20
WAFER KIT (POLY/WIRE COMBO)	PWC60	PWC72	PWC84
WEIGHT (lb)	990	1120	1250

All poly wafers available, please contact your dealer.

BROOM SPEED

FLOW RATE (gpm)	SPEED (rpm)
16	154
18	173
20	192
22	212
24	231

Speeds are the same for all widths.

Pick-Up Broom Main Assembly

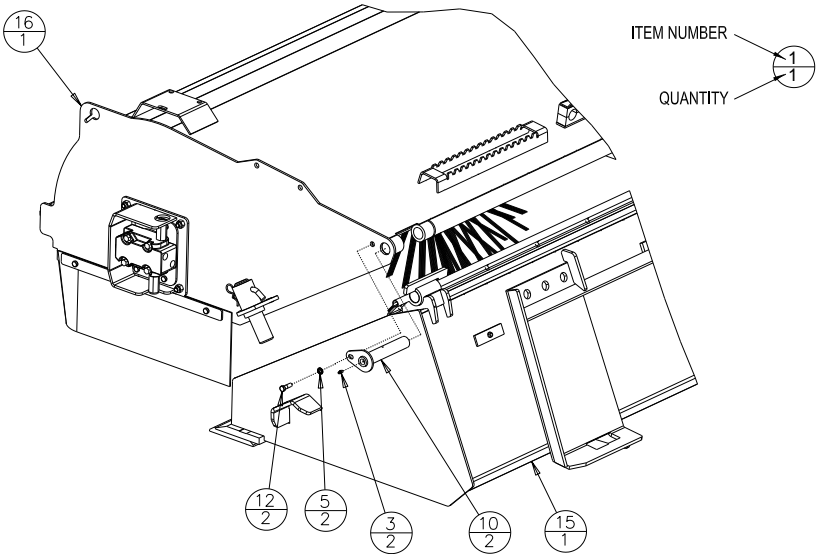

Figure 1.

Pick-Up Broom Seals and Edge

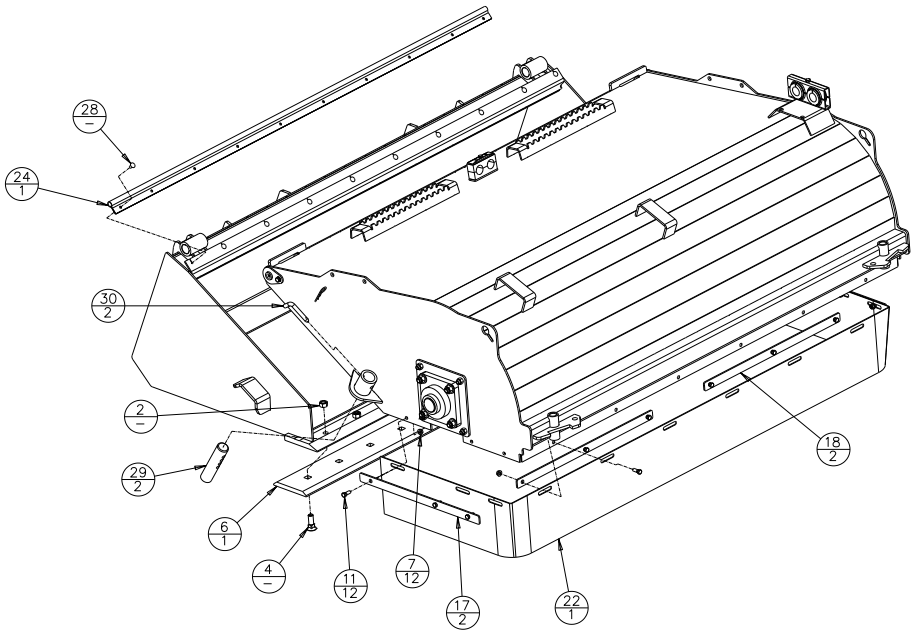

Figure 2.

Hydraulic Component Assembly

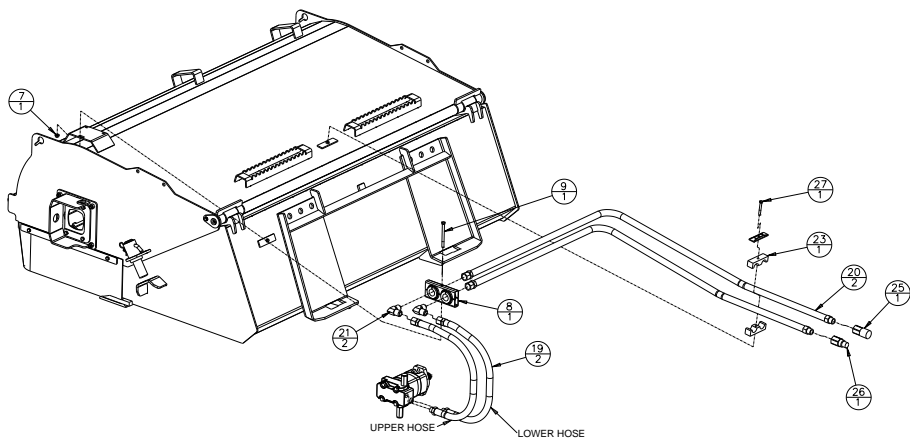

Figure 3.

Standard Coupler Assembly

- Connect female coupler to upper hose/upper motor port.
- Connect male coupler to lower hose/lower motor port.

Pick-Up Broom Core and Shaft Assembly

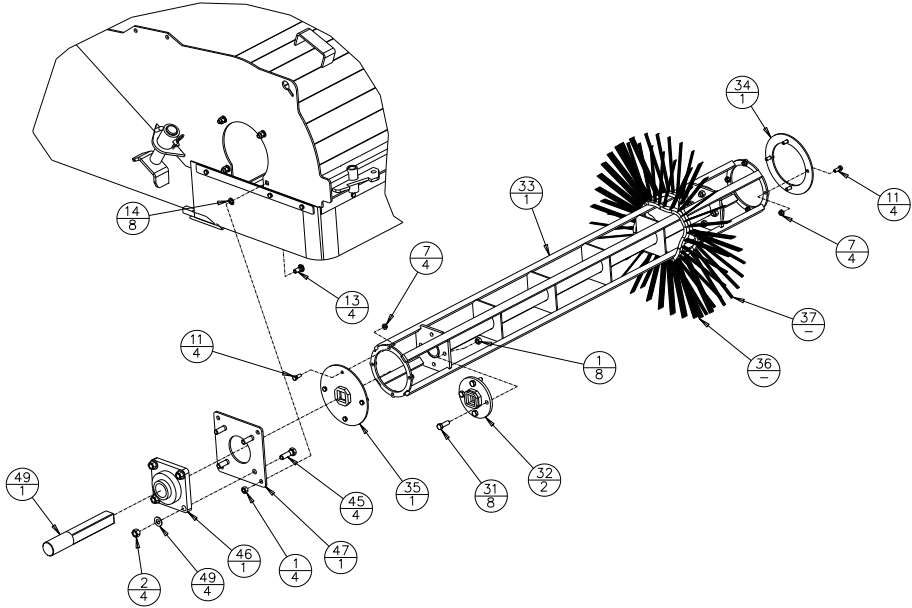

Figure 4.

Pick-Up Broom Hydraulic Motor Assembly

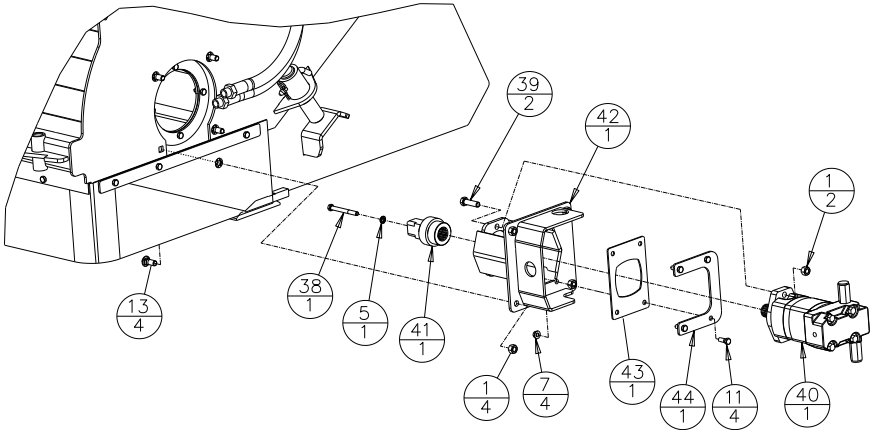

Figure 5.

Optional Gutter Brush Assembly

ITEM	PART NO.	QTY	DESCRIPTION
1	1003PP	2	1/2"-13 REVERSE LOCK NUT
2	1034PP	1	1/4"-28 STRAIGHT GREASE ZERK
3	1083PP	1	3/8" USS FLAT WASHER
4	5093VP	1	HINGE PIN
5	5146PP	2	1" X 10GA MACHINERY BUSHING
6	5147PP	2	1" EXTERNAL SNAP RING
7	5225PP	2	1/2"-13 X 1 3/4" LG HHCS
8	6140PP	5	3/8"-16 TOP LOCK FLANGE NUT
9	6721PP	4	3/8"-16 X 2 1/4" LG HHCS
10	6727PP	2	ADAPTER 8MJ TO 8MB
11	6998PP	1	ELBOW 90 LONG 6MJ TO 6MB
12	7331PP	3	7/16"-14 X 1" LG HHCS
13	7333PP	3	7/16" LOCK WASHER
14	7797PP	1	HYD HOSE 1/4" X 41 1/2" LG 6FJX TO 6FJX
15	7850PP	1	3/8"-16 X 1 1/4" LG HHCS
16	7968PP	1	7/8" X 8" LG HITCH PIN
17	8263PP	4	ADAPTER 12MJ TO 12MB
18	8264PP	2	ELBOW 90 12MJ TO 12FJX
19	8404VW	1	GUTTER BROOM PIVOT WELDMENT
20	8408VW	1	GUTTER BROOM ARM WELDMENT
21	8412VW	1	GUTTER BROOM BRUSH MOUNT WDT
22	8414PP	1	GUTTER BRUSH
23	8459PP	2	HYD HOSE 1/2" X 100" LG 10MB TO 8FJX
24	1012PP	1	ELBOW 90 6FJX TO 6MJ
25	8469PP	1	MOTOR GUTTER BRUSH
26	8470PP	1	1/4" RETAINING WASHER
27	8471PP	1	1/4" LOCK WASHER
28	8472PP	1	1/4"-20 X 1 1/4" LG HHCS
29	8473PP	1	1/4" X 42" LG CHAIN
30	8474PP	1	MANIFOLD VARIABLE CONTROL
31	8679PP	3	7/16" SAE FLAT WASHER
32	1113PP	4	3/8" X 1 1/2" FENDER WASHER
33	7984PP	1	ADAPTER 6MJ TO 4MB

Optional Gutter Brush Manifold Assembly

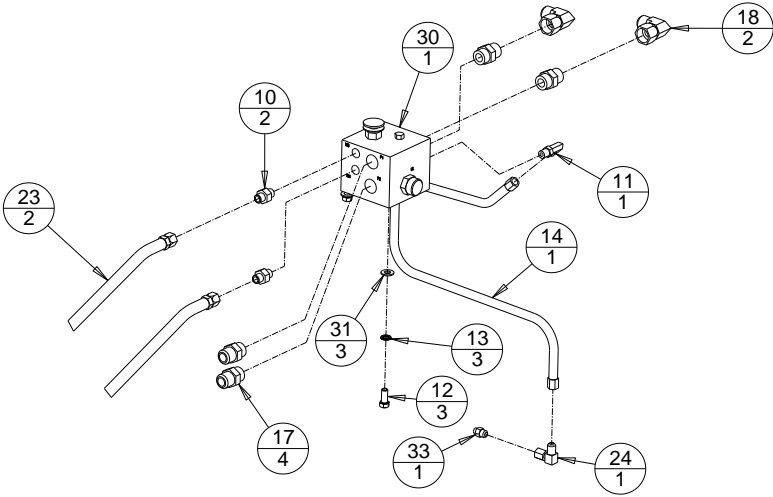

Figure 6.

Standard Gutter Brush Connections (Right Side Installation)

- Manifold port M1, lower motor port.
- Manifold port M2, upper motor port.
- Manifold port P1, male coupler.
- Manifold port P2, female coupler.
- Manifold port C, motor case drain.
- Manifold port M3, gutter brush motor port A.
- Manifold port M4, gutter brush motor port B.

Optional Gutter Brush Assembly

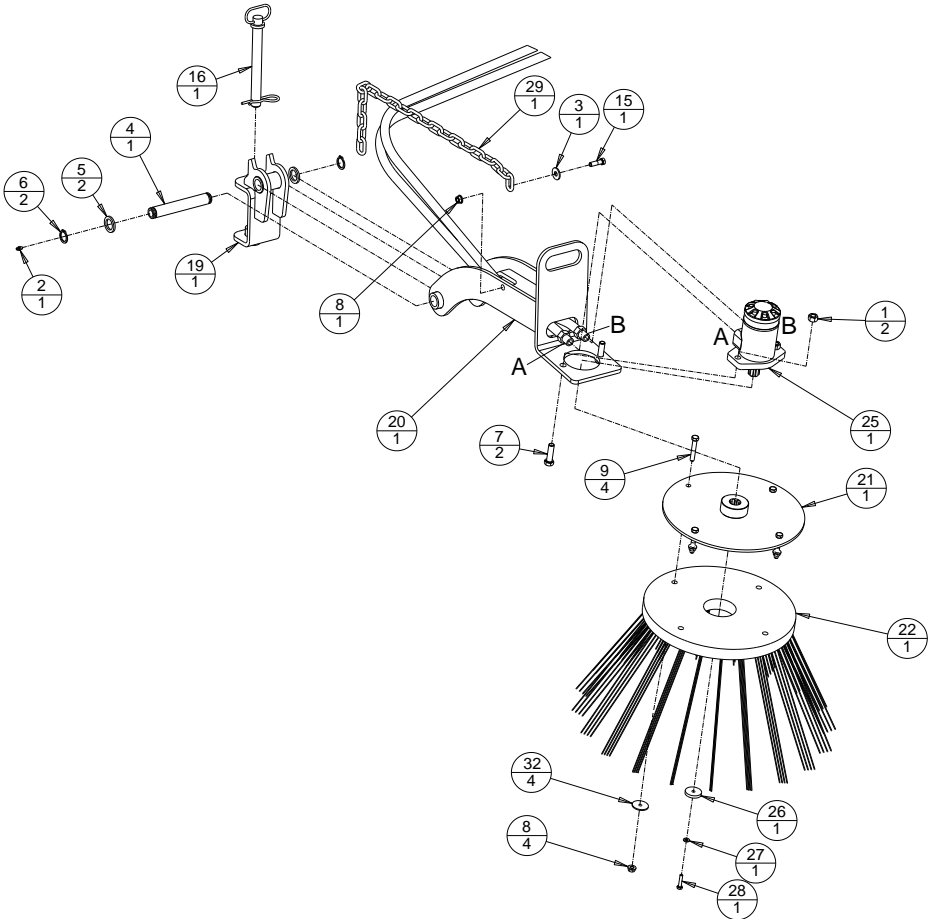

Figure 7.