

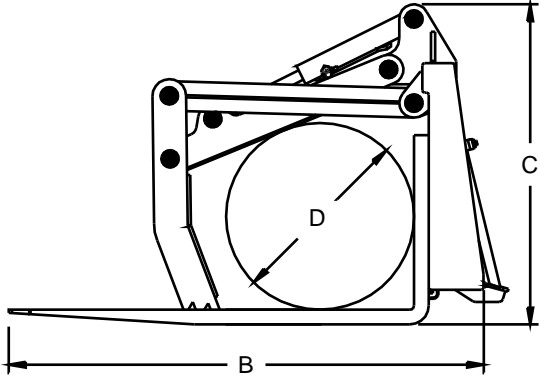

Pallet Fork Grapple Specifications

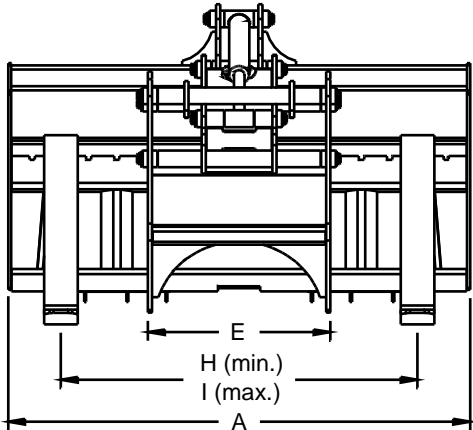

MODEL	PFG48
A) Overall Width (Inches)	54.8
B) Overall Depth (Inches)	56.3
C) Overall Height, Closed (Inches)	38.1
D) Minimum Closed Diameter (Inches)	22.3
E) Overall Grapple Width (Inches)	21.6
F) Overall Height, Open (Inches)	56.1
G) Grapple Jaw Opening (Inches)	47.3
H) Minimum Tine Space (Inches)	8.9
I) Maximum Tine Space (Inches)	49.1
Approximate Weight (Pounds)	850

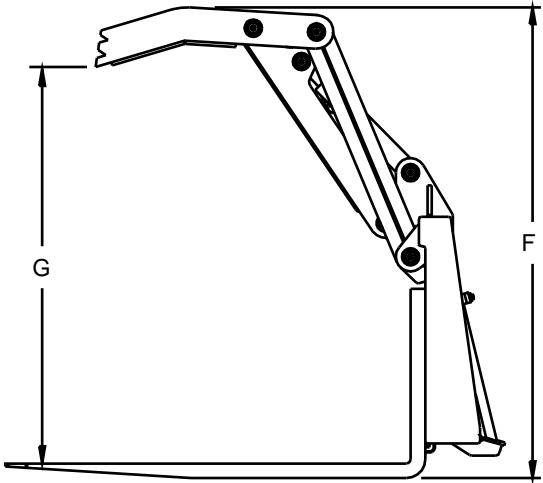

- Recommended for loaders with operating capacities greater than 1500 pounds.
- 1 3/4" X 4" X 48" long forged solid tines.
- 6200 pound capacity, with load center 24" from frame.
- 1 cylinder grapple with 1 1/4" diameter hinge pins.
- 2" bore, 8 3/8" stroke cylinder with 1 1/4" rod and 1 1/4" cylinder pins.
- Hoses from grapple to loader and couplers are included.

Specifications and designs are subject to change without notice.

Virnig Manufacturing Inc.
800-648-2408
www.virnigmfg.com