

VIRNIG

Utility Bucket with Grapple Specifications

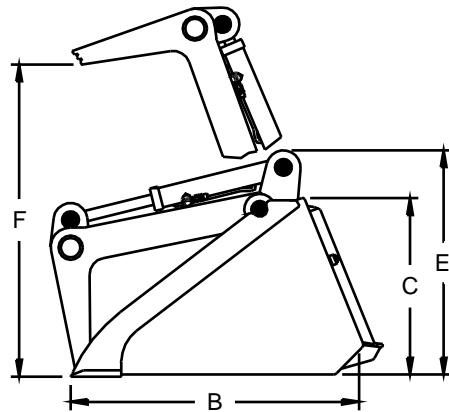
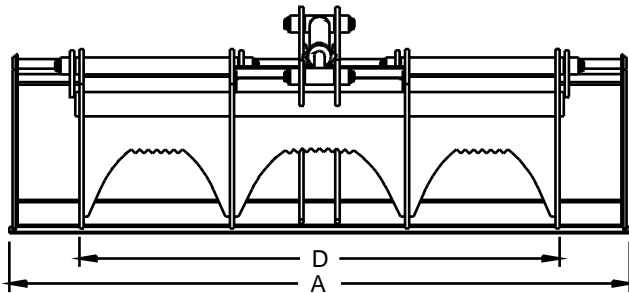

MODEL	DBG60	DBG66	DBG72	DBG78
A) Overall Bucket Width (Inches)	61.5	67.5	73.5	79.5
B) Bucket Depth (Inches)	33.5			
C) Bucket Height (Inches)	20.5			
D) Overall Grapple Width (Inches)	56.9			
E) Height with Grapple Closed (Inches)	26.8			
F) Grapple Jaw Opening (Inches)	37.0			
Approximate Weight (Pounds)	845	875	905	950

- Recommended for loaders with operating capacities less than 2400 pounds.
- 3/4" X 6" weld on cutting edge with holes to accept bolt on edge.
(Bolt on Edges, Toothbars, and Weld on Teeth available.)
- 1/2" grade 50 reinforced plate grapple jaw tines, 50,000 psi minimum yield strength.
- 1 cylinder grapple with 1 1/4" diameter hinge pins.
- 2" bore, 8 3/8" stroke cylinder with 1 1/4" rod and 1 1/4" cylinder pins.
- Hoses from grapple to loader and couplers are included.

Specifications and designs are subject to change without notice.

Virnig Manufacturing Inc.
800-648-2408
www.virnigmfg.com