

VIRNIG

Brush Rake Grapple Specifications

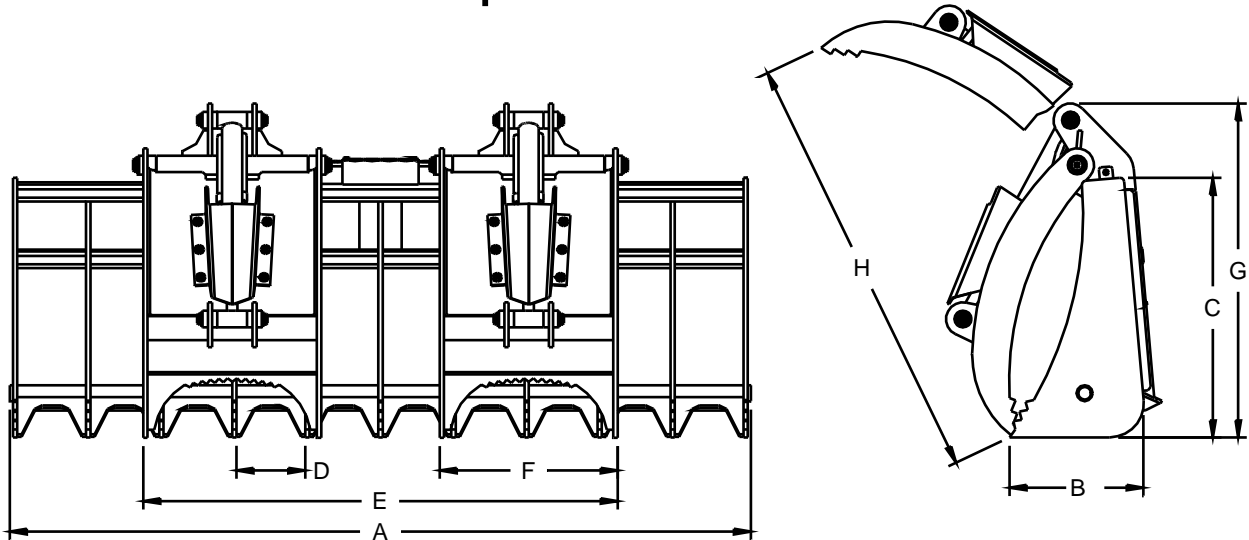

MODEL	BRV72	BRV78	BRV84	BRV90
A) Overall Bucket Width (Inches)	74.3	80.9	87.5	94.1
B) Bucket Depth (Inches)	15.8			
C) Bucket Height (Inches)	30.9			
Number of Tines (With Sides)	10	11	11	12
D) Space Between Tines (Inches)	8.2	8.0	8.6	8.4
E) Overall Grapple Width (Inches)	56.0			
F) Independent Grapple Width (Inches)	21.0			
G) Height with Grapple Closed (Inches)	39.8			
H) Grapple Jaw Opening (Inches)	51.5			
Approximate Weight (Pounds)	1050	1095	1115	1160

- Recommended for loaders with operating capacities greater than 1500 pounds.
- 1/2" grade 80 reinforced plate bucket tines, 80,000 psi minimum yield strength.
- 1/2" grade 50 reinforced plate grapple jaw tines, 50,000 psi minimum yield strength.
- 2 cylinder independent grapple with 1 9/16" diameter hinge pins.
- 2" bore, 8 3/8" stroke cylinders with 1 1/4" rods and 1 1/4" cylinder pins.
- Hoses from grapple to loader and couplers are included.
- Cylinder Guards standard.

Specifications and designs are subject to change without notice.

Virnig Manufacturing Inc.
800-648-2408
www.virnigmfg.com