

Angle Broom

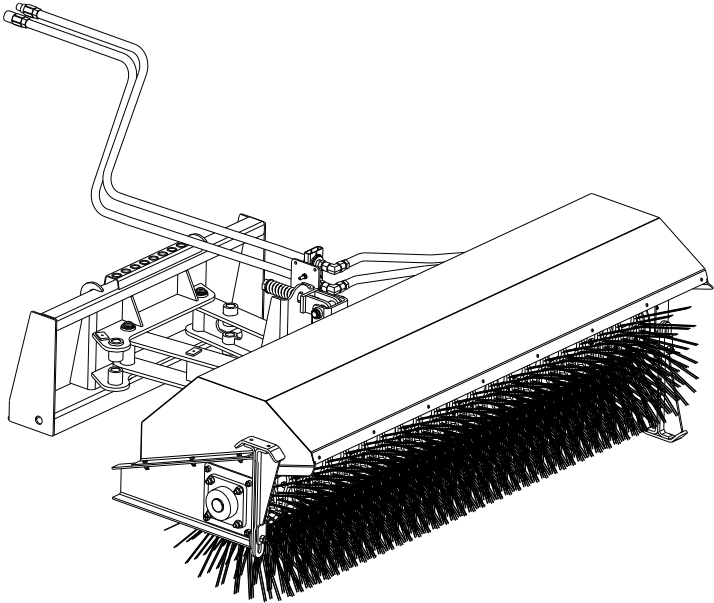

Model Number _____ VAB _____.

Serial Number _____.

Serial Number 101050-103183
Manufacture Date 08/28/14 – 12/09/14

Phone: 320-393-7080

02/29/12

VAB

Revised 08/27/14

Features of Virnig Mfg. Inc. Angle Broom include:

- Centering swing linkage better centers broom in front of loader when angled.
- Optional Hydraulic Angle with Electric Control utilizes either the machines electrical package or an add-on control box.
- 15-25 gpm operating flow rate range and 2000 – 3500 psi operating pressure range.
- Easy exchange of wafers, do not have to disconnect hydraulic lines to change wafer sections.
- Hydraulic pressure relief valves on motor allow broom to operate in both directions.
- Direct drive design with replaceable drive components.
- 160° standard hood, optional deflector provides an additional 30° of coverage and can be “uninstalled” by simply locking in the storage position without removing.
- Recommended for loaders with an operating capacity greater than 1500 lb.

Initial Use

- Read and understand all warning information in this manual before operating this attachment.
- Check that quick-tach on frame fits onto loader properly. Pins must engage through 3/8” plates at bottom of quick-tach.
- Slowly roll back attachment. Make sure there is no interference between attachment and loader.
- Do not connect this attachment to high flow couplers.
- Make sure hoses do not pinch during roll back.
- Never exceed the maximum attachment operating pressure of 3500 psi.
- After Angle Broom is mounted to the loader, lift or roll back the Angle Broom so the storage stands are not contacting the ground. Flip storage stands into “storage” position before operation of the Angle Broom.
- With the Angle Broom off of the ground, engage the auxiliary hydraulics using the “detent” position on the machine. Check the rotation of the broom (broom should be sweeping away from the machine.) If this rotation does not match the “detent” position of your machine, switch the couplers on the lead hoses.
- If Angle Broom is equipped with manual angle, swing the broom head through its cycle to check that the lead hoses do not bind or catch anywhere. Make sure the broom is not operating and the machine is

shut off when changing the broom angle manually.

Initial Use (cont.)

- If the Angle Broom is equipped with hydraulic angle, with the broom running in the sweeping direction, engage the electrical controls and cycle the broom head from side to side and check that the lead hoses do not bind or catch anywhere. Broom will not angle when the broom is running in reverse.
- Do not store Angle Broom with weight on the wafers as this may deform the bristles reducing the sweeping efficiency. Use the storage stands to support the weight of the broom head.

Operation

- Always follow safety and operating information in this manual.
- Always follow all safety and operating instructions of the loader.
- Never remove material deflectors or warning labels.
- Never operate Angle Broom unless you have been properly trained.
- Make sure all safety labels are in place, look in this manual for their locations.
- Do not sweep toward people, buildings, etc. that may be injured or damaged by flying debris.
- Always relieve pressure before connecting or disconnecting hydraulic hoses.
- Clean any debris from attachment. Pay special attention to any debris in quick-tach area.
- The angle broom is designed to be operated so that the brush sweeps debris away from the operator (brush spins clockwise when looking from the motor end). The brush will spin in the opposite direction, but has limited power when in contact with the ground.

Sweeping Recommendations

- Sweep with the wind whenever possible to provide more efficient operation and keep debris off of the operator.
- When sweeping on rough terrain, reduce machine ground speed to minimize “bouncing” of broom head.
- Debris direction can be controlled by angling the broom head.
- Avoid excessive down pressure on the broom head. Brooms sweep with the tips of the wafers; therefore, the sweeping contact pattern should be about 2”-4”. Unnecessary down pressure promotes excessive wear and premature failure of wafers. The weight of the broom head should provide adequate down pressure for sweeping.

Sweeping Recommendations (cont.)

- When sweeping snow, increase brush speed and decrease travel speed. This allows the snow to be removed effectively. In heavy or deep snow, use multiple passes to clear the snow.
- Use of the optional deflector will limit distance swept material is thrown.

Manual Angle Operation

- Manual angle operation is achieved with a hitch pin located on the centering swing linkage. Angles that are available are straight, 27° right or 27° left.
- To change the angle of the brush head, lift broom head off of the ground, remove the pin, swing the head in the desired direction and reinstall pin. Make sure broom is not rotating and machine is shut off when changing the angle manually.

Optional Hydraulic Angle with Electric Control Operation

- If the machine has the electrical package (usually 8 or 14 pin connector for skid loaders), connect the electrical plug to the plug on the boom arm of the loader when hooking up the attachment to the loader. The angle of the broom should now be controlled by primary electrical switch located in the operator station of the machine.
- If the machine does not have an electrical package, there are 2 options to make the Hydraulic Angle with Electric Controls work. If the machine has a 12 volt accessory plug (cigarette lighter), you can use the optional control box for power. If the machine does not have a 12 volt accessory plug, a 12 volt accessory outlet is available from Virnig Manufacturing to connect to the battery of the machine and then utilizes the optional control box.
- In either of the above scenarios, the broom needs to be running in the sweeping direction before the electro-hydraulic angle will function. The hydraulic angle will not work if the broom is running in reverse.

Maintenance

*Before each use and after every 10 hours of operation

- Grease hinge pins, linkage pins and bearing (8 fittings on Manual Angle, 10 fittings on Hydraulic Angle with Electric Control).
- Check for wear on wafers. If the outside diameter of the wafers is one half of the original diameter, the wafers need to be replaced. The original diameter of the wafers for the Angle Broom is 32”.
- Make sure all safety labels are in place, look in this manual for locations.
- Check for loose, worn, or missing parts, repair or replace as needed.
- Remove any foreign debris such as string, wire, etc. that may have wrapped around the brush head.
- Inspect motor, valve, hydraulic fittings, and hoses for leaks and damage. Replace as needed. Make sure machine is shut off and hydraulic pressure is relieved before checking for leaks. Never use hands to check for high pressure hydraulic leaks.
- The pressure relief valves require no maintenance. The valves are pre-set and require no adjustment. Changing settings may cause damage to the motor. Please call Virnig Mfg. Inc. with any questions or problems regarding the pressure relief valves.
- Contact your dealer for any required replacement parts.

Brush Replacement Procedure

- Remove the 4 nuts (Item #1, see “Angle Broom Core Installation” section) holding the Hydraulic Motor Assembly and remove the Hydraulic Motor Assembly.
- Remove the 4 nuts (Item #1, see “Angle Broom Core Installation” section) holding the Angle Broom Shaft Assembly and remove the Angle Broom Shaft Assembly.
- The core should be free from the brush head. Lift brush head and remove to expose core.
- Remove the retaining plate from one end of the core (See “Core Assembly” section).
- Remove old brush sections. Inspect drive bars for indentations or excessive wear. Replace core cage if damage is evident.
- Stand core on end with retaining plate still attached and install the new brush sections making sure the drive pins of the wafer engage one of the core drive bars. For a snug fit, install consecutive wafers so that the drive pins are 180° apart.
- Reinstall the retaining plate and lay core on ground. When handling the core, do not use the wafers to move the core.
- Lower brush head over core with new brush sections.
- Reinstall Angle Broom Shaft Assembly into core and secure with nuts.
- Before reinstalling motor, remove the 3/8” bolt (Item #45, see “Angle Broom Hydraulic Motor Assembly” section) holding the Drive Adapter (Item #48) on the Hydraulic Motor (Item #47) and apply a thin layer of grease to the splines of the motor. Reinstall Drive Adapter to the Hydraulic Motor.
- Reinstall Hydraulic Motor Assembly and secure with nuts.

Warning Labels on Angle Broom Attachment

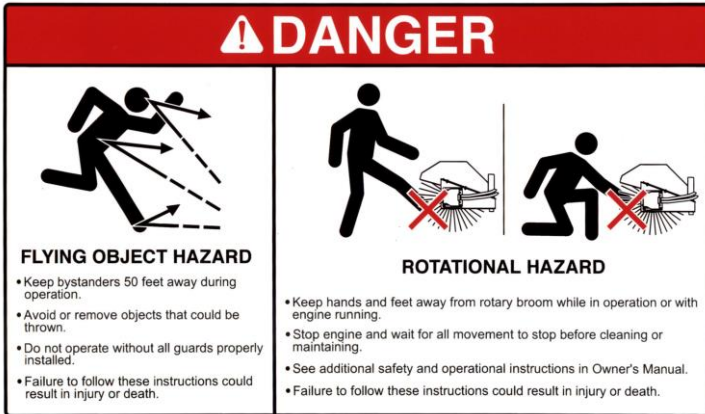

This label is located on the front and sides of hood.
This label has several important instructions for safe operation regarding flying object hazards and rotational hazards.

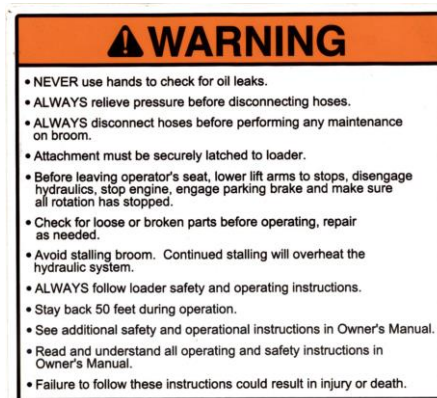

This label is located on sides of the hood and on the frame near the quick-tach.
All bystanders must stay clear during operation.
This label has several important instructions that must be followed for safe operation of this attachment.

Warning Labels on Angle Broom Attachment (cont.)



This label is located on the rear of the hood frame weldment on each side of the attachment.

This label has several important instructions that must be followed for safe operation of this attachment.



This label is located on the knuckle weldment near the pivot locations. Always keep hands clear of linkages when loader hydraulic system is operational.

25 GPM MAX

This label is located on the hood facing the operator.

This label indicates the maximum flow rate for this attachment.

Angle Broom (VAB) Parts List

ITEM	PART NO.	QTY	DESCRIPTION
1	1003PP	18	1/2"-13 REVERSE LOCK NUT
2	1008PP	6	5/8"-11 TOP LOCK NUT
3	1034PP	7	1/4"-28 STRAIGHT GREASE ZERK
4	1075PP	7	3/8" LOCK WASHER
5	1083PP	6	3/8" USS FLAT WASHER
6	1094PP	10	1 1/4" X 10GA MACH BUSHING
7	1095PP	10	1 1/4" EXTERNAL SNAP RING
8	1111PP	10	1 1/4" DIA X 1 9/16" LG BUSH
9	2137VP	4	CYLINDER PIN
10	2434VP	1	MANURE GRAPPLE HINGE PIN
11	5093VP	1	HINGE PIN
12	5130PP	2	5/8"-11 X 2 1/2" LG HHCS
13	5146PP	2	1" X 10GA MACHINERY BUSHING
14	5147PP	2	1" EXTERNAL SNAP RING
15	6140PP	23	3/8"-16 TOP LOCK FLANGE NUT
16	6683PP	2	1" SAE FLAT WASHER
17	8734PP	1	COUPLER FEMALE 12FB CUP
18	8735PP	1	COUPLER MALE 12FB CUP
19	7246PP	1	1"-8 TOP LOCK NUT
20	7726PP	1	3/4" HOSE CLAMP ASSY STANDARD
21	7729PP	1	3/8"-16 X 4 1/2" LG HHCS
22	7849PP	28	3/8"-16 X 1" LG HHCS
23	7876VW	1	ANGLE BROOM QT FRAME WELDMENT
24	7883VW	1	ANGLE BROOM FOLLOWER LINK WDT
25	7886VW	1	ANGLE BROOM DRIVER LINK WDT
26	7890VW	1	ANGLE BROOM KNUCKLE WELDMENT
A 27	-----	1	ANGLE BROOM HOOD WELDMENT
28	7918VW	2	ANGLE BROOM STAND WELDMENT
29	7960VW	1	SPRING RETAINER WELDMENT
30	7964PP	8	1/2"-13 X 1 1/4" LG CB
31	7965PP	8	1/2" PUSHNUT BOLT RETAINER
32	7966PP	1	SPRING COMPRESSION ANGLE BROOM
33	7967PP	1	1"-8 X 9" LG HHCS
34	7968PP	1	7/8" X 8" LG HITCH PIN
35	8276PP	2	HYD HOSE 3/4" X 72" LG 12MB TO 12FJX
A 36	-----	2	HYD HOSE 3/4" 10MB TO 12FJX
37	8460PP	2	ELBOW 90 12MJ TO 12MJ
A 38	-----	1	ANGLE BROOM HOOD FRAME WDT

Angle Broom (VAB) Parts List (cont.)

ITEM	PART NO.	QTY	DESCRIPTION	
	39	5226PP	8	1/2"-13 X 1 1/2" LG HHCS
A	40	-----	1	ANGLE BROOM CORE WELDMENT
	41	7928VW	1	ANGLE BROOM SHAFT GUIDE WDT
	42	7931VW	2	ANGLE BROOM ADAPTER FLANGE WDT
	43	7933VP	1	VAB BRUSH RETAINING PLATE
A	44	7990PP	--	WAFER 32 POLY/WIRE COMBO
	45	6970PP	1	3/8"-16 X 3 1/2" LG HHCS
	46	5225PP	2	1/2"-13 X 1 3/4" LG HHCS
	47	9437PP	1	MOTOR ANGLE BROOM
B	47A	9413PP	2	RELIEF VALVE BROOM MOTOR
	48	7908VW	1	HYD MOTOR DRIVE ADAPTER WDT
	49	8427VW	1	BROOM HYDRAULIC MOTOR MNT WDT
	50	8508VP	1	BROOM MOTOR COVER
	51	7719PP	4	5/8"-11 X 2" LG HHCS
	52	7773PP	1	2" BEARING W/4 HOLE FLANGE
	53	7916VP	1	VAB BEARING MOUNT PLATE
	54	7917VP	1	ANGLE BROOM SHAFT
	55	7957VP	4	5/8" SAE FLAT WASHER

A - See Table 1.

B - Broom Motor Replacement Part.

Table 1

MODEL	VAB60	VAB72	VAB84	VAB96
ANGLE BROOM HOOD WELDMENT	8575VW	8589VW	7895VW	8268VW
ANGLE BROOM HOOD FRAME WDT	8572VW	8586VW	8497VW	8500VW
HYD HOSE 3/4" 10MB TO 12FJX	8680PP 54" LG	8680PP 54" LG	8856PP 60" LG	8277PP 66" LG
ANGLE BROOM CORE WELDMENT	8578VW	8592VW	7922VW	8273VW
NUMBER OF WAFERS	30	36	42	48
WAFER KIT (POLY/WIRE COMBO)	AWC60	AWC72	AWC84	AWC96
WEIGHT (lb)	970	1035	1095	1160

All steel or poly wafers available, please contact your dealer.

Broom Speed

FLOW RATE (gpm)	SPEED (rpm)
16	154
18	173
20	192
22	212
24	231

Speeds are the same for all widths.

Angle Broom Linkage Assembly

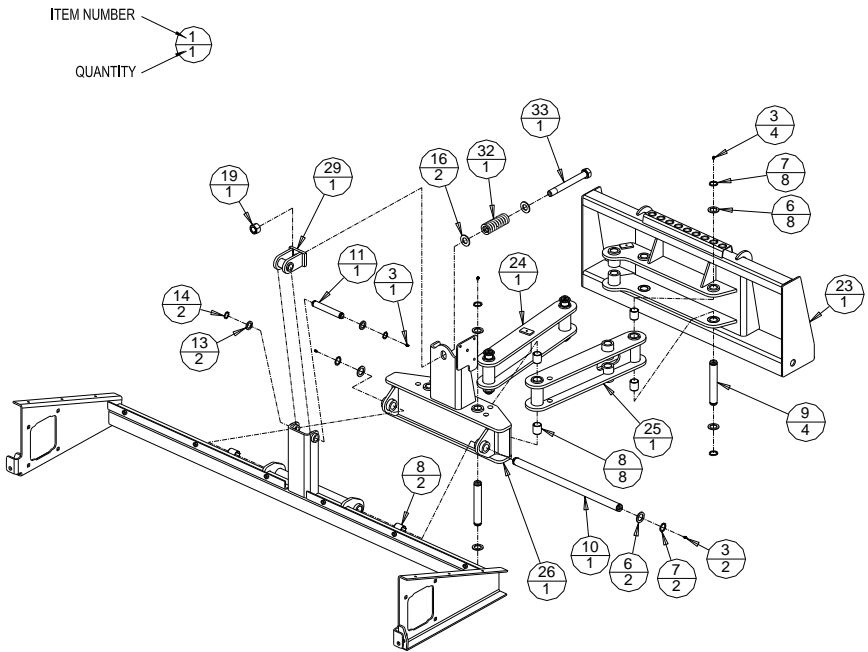

Angle Broom Core Installation

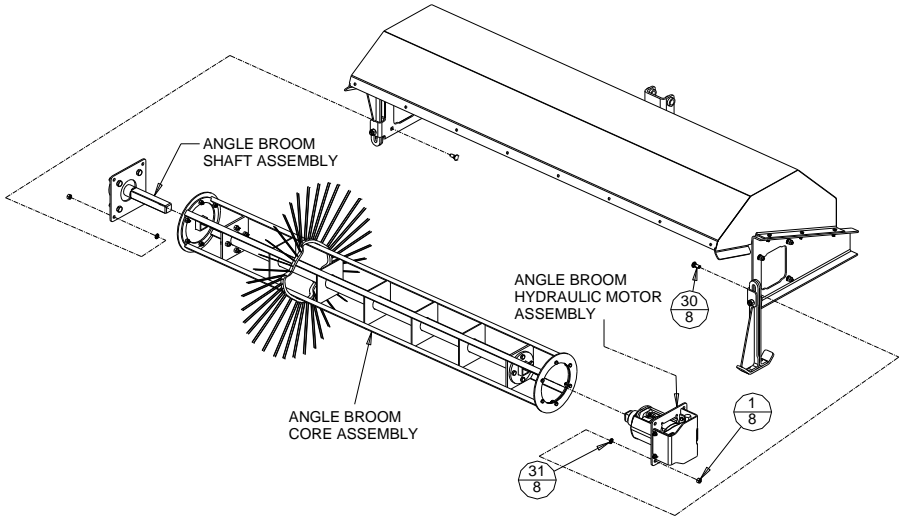

Hood and Stand Installation

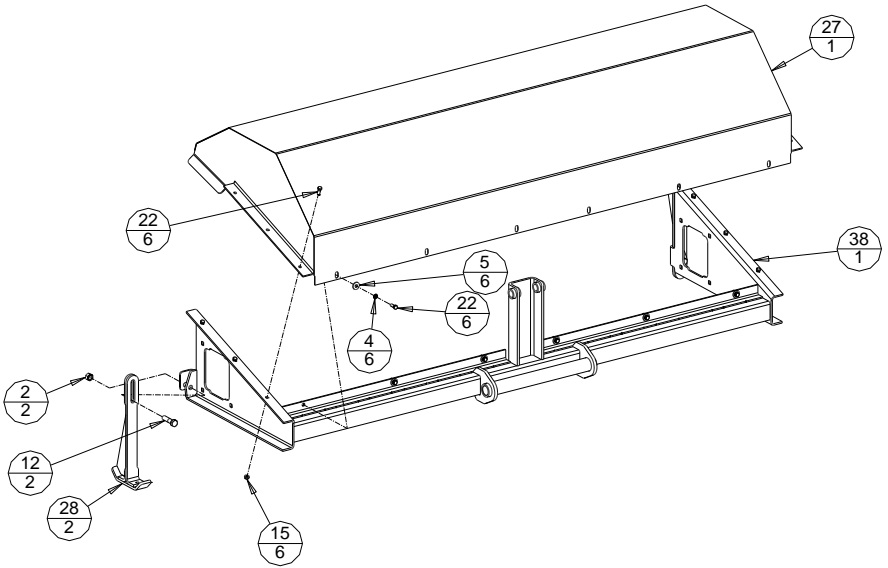

Hydraulic Component Assembly

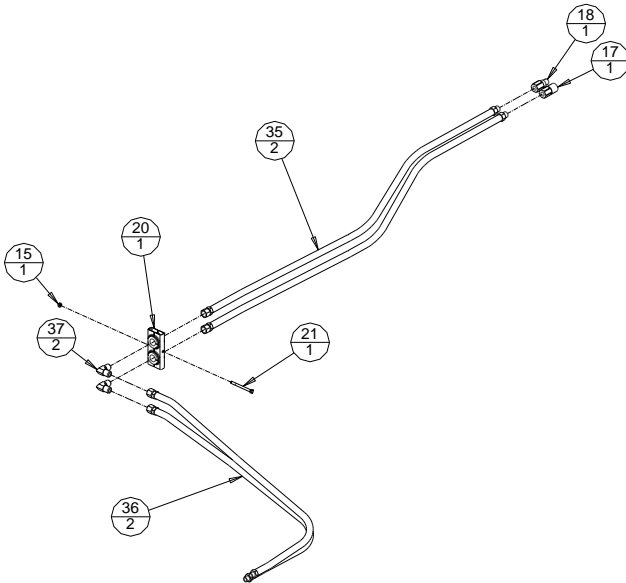

Manual Angle Adjustment

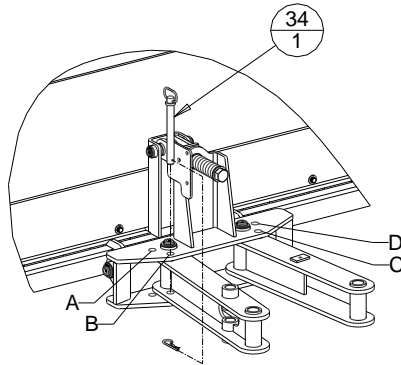

Pin location for various discharge directions:

- Left side discharge: Pin location A.
- Right side discharge: Pin location D.
- Straight discharge: Pin location B or C.

Core Assembly

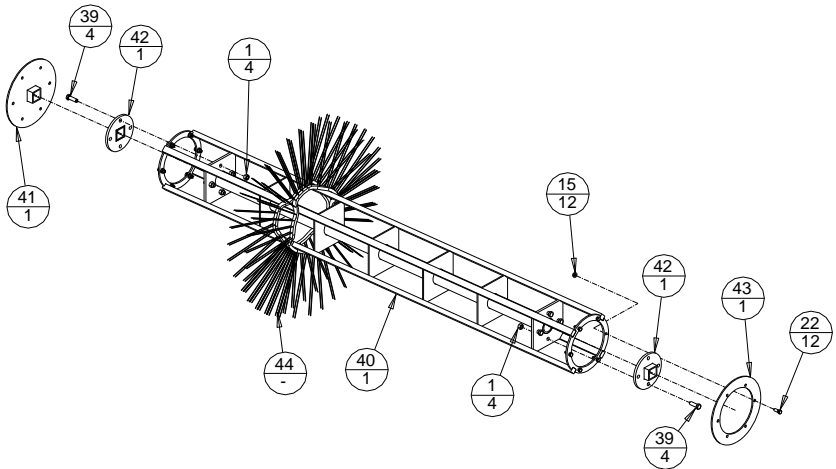

Angle Broom Hydraulic Motor Assembly

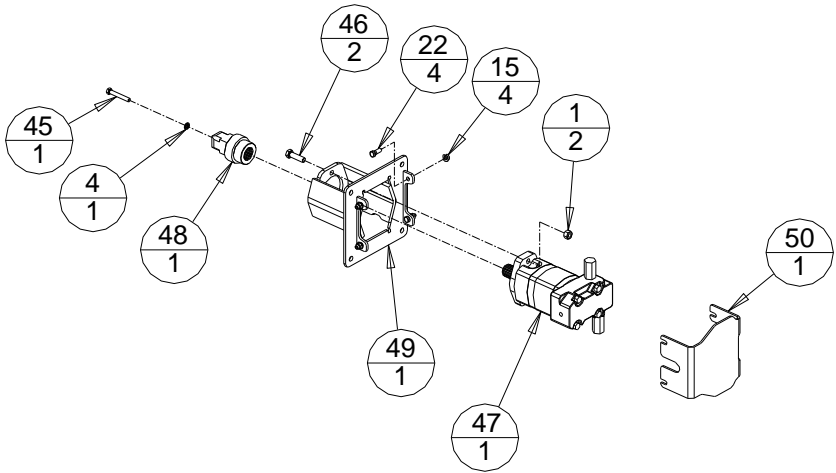

Angle Broom Shaft Assembly

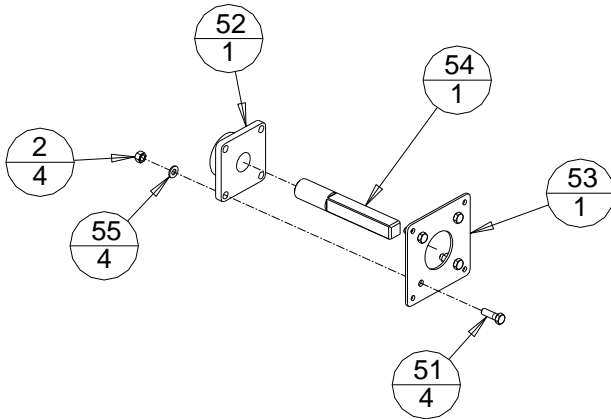

Optional Hydraulic Angle Assembly

ITEM	PART NO.	QTY	DESCRIPTION
1	1012PP	1	ELBOW 90 6FJX TO 6MJ
2	1034PP	2	1/4"-28 STRAIGHT GREASE ZERK
3	1067PP	2	HOSE CLAMP FOR 1/4" HOSES
4	1075PP	3	3/8" LOCK WASHER
5	1083PP	3	3/8" USS FLAT WASHER
6	1094PP	4	1 1/4" X 10GA MACH BUSHING
7	1095PP	4	1 1/4" EXTERNAL SNAP RING
8	1117PP	2	5/16"-18 X 1 1/2" LG HHCS
9	1125PP	1	HYD HOSE 1/4" X 64" LG 6FJX TO 6FJX
10	1127PP	1	HYD HOSE 1/4" X 72" LG 6FJX TO 6FJX
11	2137VP	2	CYLINDER PIN
12	6682PP	1	ANGLE BROOM CYLINDER
13	7796PP	1	ADAPTER 6MJ TO 6MB
14	6997PP	3	ELBOW 90 6MJ TO 6MB
15	7849PP	3	3/8"-16 X 1" LG HHCS
16	8263PP	4	ADAPTER 12MJ TO 12MB
17A	9584PP	1	BROOM MANIFOLD
17B	9602VA	1	BROOM WIRE HARNESS
A	9599PP	2	BROOM COIL W/ DEUTSCH PLUG

A – Broom Coil, Replacement Part Only.

Optional Hydraulic Angle Assembly

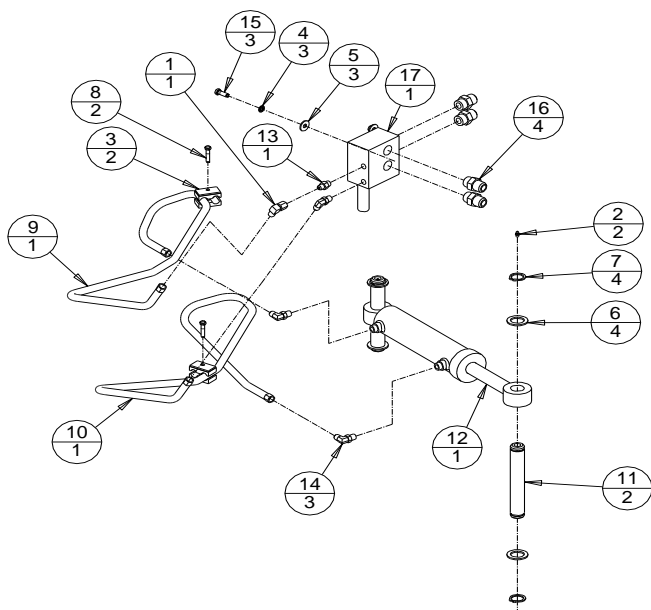

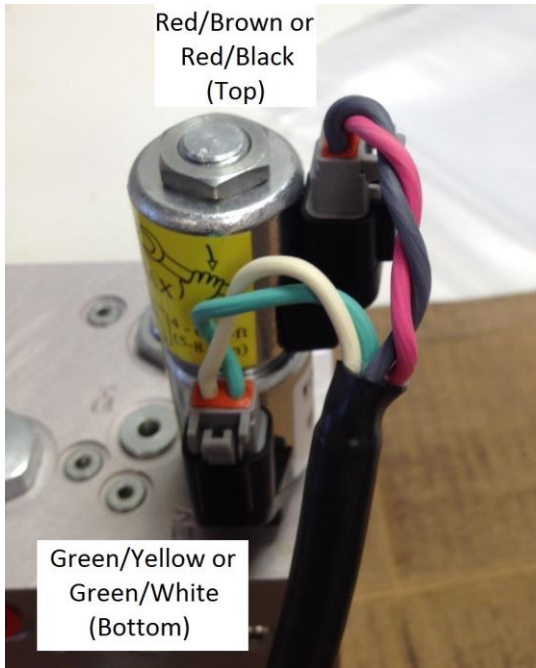

Optional Deflector

ITEM	PART NO.	QTY	DESCRIPTION
C 1	1075PP	-	3/8" LOCK WASHER
2	6863PP	2	7/16" X 1-3/4" LG LYNCH PIN
C 3	7849PP	-	3/8"-16 X 1" LG HHCS
C 4	-----	1	ANGLE BROOM DEFLECTOR WDT

C - See Table 2.

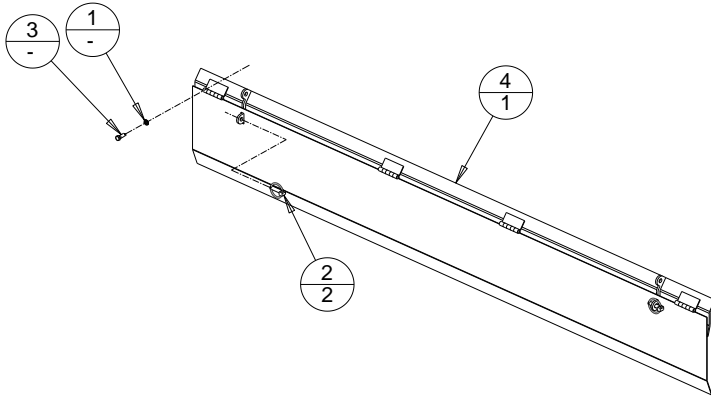

Table 2

MODEL	ABDF60	ABDF72	ABDF84	ABDF96
ANGLE BROOM DEFLECTOR WDT	8582VW	8596VW	8520VW	8600VW
HARDWARE QUANTITY	6	7	8	9
WEIGHT (lb)	35	40	50	55