

Agitator

- Welded 3/8" cutting edge allows self loading from loose piles.
- 13.5 cu/ft (0.50 cu/yd). capacity.
- Agitator keeps sand from sticking to sides of hopper.
- Galvanized hopper grate prevents the entry of large unwanted materials.
- Bolt-on spinner blades allow for easy replacement.
- Three adjustable discharge doors allow for spreading in any direction.
- Excellent operator visibility.
- Includes 108" hoses and flat face couplers. Hoses are guarded and securely routed behind hopper.

SK105 Sand Kicker Specifications

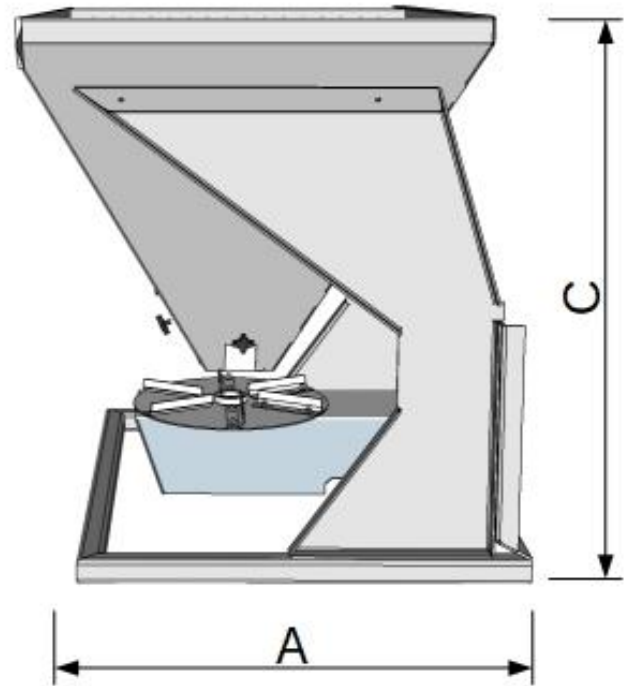
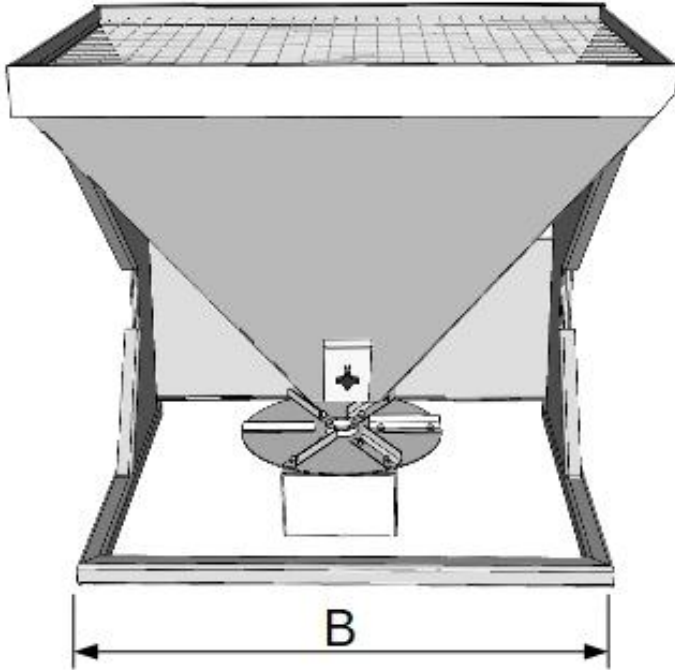

Model	SK105
A. Depth	48"
B. Width with Steps	50"
C. Height	44"
Capacity	13.5 cu/ft
Weight	480 lbs.
Spreader Diameter	18"