

TALET

EQUIPMENT

MAT GRAPPLE



Parts & Operators Manual

To The Owner

General Comments

Congratulations on the purchase of your new Talet Mat Grapple. Your unit was carefully designed and manufactured to give you many years of dependable service. Your Mat Grapple will require some minor maintenance to keep it in top working condition. Be sure to observe all maintenance procedures and safety precautions in this manual and the safety decals located on any equipment on which it is mounted.

Service

When servicing your Mat Grapple remember to use only original manufacturer replacement parts. Substitute parts may not meet the standards required for safe, dependable operation. To facilitate parts ordering, record the model and serial number in the space provided on the page. This information may be obtained from the identification plate located on your bucket.

Model _____ Serial No. _____

Our parts department needs this information to insure that you receive the correct parts for your specific model.

Safety Precautions



Safety Alert Symbol

This is the "Safety Alert Symbol" used by this industry. This symbol is used to warn of possible injury. Be sure to read all warnings carefully. They are included for your safety and for the safety of others working around you.

Signal Words

Note the use of signal words Danger, Warning, and Caution with the safety messages. The appropriate signal word for reach has been selected using the following guidelines:

- **DANGER:** Indicates an immediate hazardous situation in which, if not avoided, will result in death or serious injury. This signal word is to be limited to the most extreme situations; typically for machine components which, for functional purposes, cannot be guarded.
- **WARNING:** Indicates a potentially hazardous situation in which, if not avoided, can result in death or serious injury and indicated hazards that exposed when guards are removed. It may also be used to alert against unsafe practices.
- **CAUTION:** Indicates a potentially hazardous situation which, if not avoided, may result in minor or moderate injury. It may also be used to alert against unsafe practices.

Safety Rules

To insure skid steer stability, and to prevent tipping, always observe the following safety rules:

- Keep clear of unit while in operation.
- Before operating the skid steer, read the operating and safety instructions provided by the manufacturer. Observe all warnings and caution particularly those which describe the use of seat belts and other operator restraints and those which describe the proper way of carrying loads as close to the ground as possible.
- When using the Mat Grapple be sure that the proper weight of the load is not too heavy. A light load sticking out too far can have the same tipping effect on the loader as a heavy load carried too close.
- Never operate the Mat Grapple when people are standing by the unit and could be injured.
- Do not obstruct your vision when traveling or working. Carry the mats low for maximum stability and visibility when traveling.
- Operate at speeds slow enough so that you have complete control at all times. Travel slowly over rough or slippery ground and on hillsides.
- Avoid steep slopes or unstable surfaces. If you must drive on a slope, keep the load low and proceed with extreme caution. Do not drive across a steep slope under any circumstances. Drive straight up and down the slope.
- Avoid turning on an incline, if at all possible. If it is necessary, use extreme caution and make the turn wide and slow with the bucket carried low.



If you can't see where you are going then stop.

Skid-steer Loader Safety

1. Read the entire skid-steer loader operators manual before ever attempting to use the skid steer loader. This knowledge is necessary for safe operation.
2. Follow all safety decals on the skid-steer loader. Keep them clean and replace them if they become worn and hard to read.
3. Know the limitation of your equipment. Do not use equipment for anything other than what it was originally designed for.
4. Pay attention to the job at hand. Do not let your mind lose concentration on what you are doing.
5. Use your seat belt and R.O.P.S. (Roll Over Protective Structure) when operating the skid-steer loader. Keep belt and R.O.P.S. in good repair. Do not modify R.O.P.S. or seat belt. Do not remove

R.O.P.S. or seat belt. Overturning the skid-steer loader without proper R.O.P.S. and seat belt can result in death.

6. Fasten your seatbelt before and during skid steer loader operation. Remain seated at all times.
7. Do not take passengers on the skid steer loader or attachment. There is no safe place for a passenger.
8. Use hand hold when getting on and off the skid-steer loader. Failure to do so could cause a fall.
9. Inspect the skid steer loader before you try to operate the unit. Check for needed maintenance or repairs and have them done before using the equipment.
10. Never leave the skid steer loader running unattended. Always lower lift arms, set parking brake, turn off engine, and remove key.
11. Wear appropriate clothing such as safety glasses, ear plugs, etc. Do not wear loose fitting clothing; it may catch on the equipment. Always wear a hardhat when operating the skid-steer loader to prevent head injury.
12. When driving on public roads use safety light, reflectors, slow moving vehicle sign, etc., to prevent accidents. Check with local governments for regulations that may affect you.
13. Turn off the skid-steer loader before performing maintenance. If the lift arms must be left raised for any reason, use a positive lift arm lock to secure arms in place. Serious damage or personal injury could result from lift arms accidentally lowering.
14. Reduce speed when driving on rough terrain, slopes, or turning, to avoid overturning the skid-steer loader.
15. Do not smoke when refueling the skid-steer loader. Allow room in the gas tank for expansion. Wipe up any spilled liquid. Secure cap tightly when done.



Escaping fluid under pressure can have sufficient force to penetrate the skin causing serious personal injury. Fluid escaping from a very small hole can be almost invisible. Use a piece of cardboard or wood, rather than your hands, to search for suspected leaks.

Keep unprotected body parts, such as face, eyes, and arms, as far away as possible from a suspected leak. Flesh injected with hydraulic fluid may develop gangrene or other permanent disabilities. If injured by injected fluid, see a doctor at once. If your doctor is not familiar with this type of injury, ask him to research immediately to determine proper treatment.

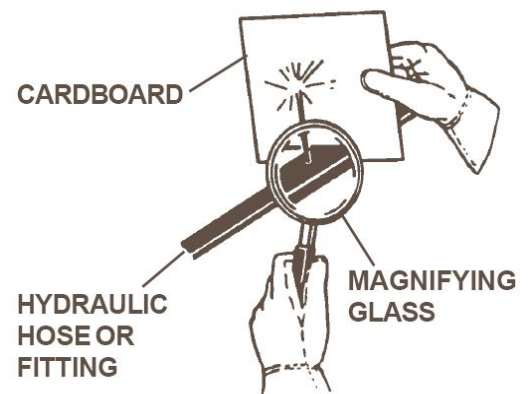

Mat Grapple Assembly

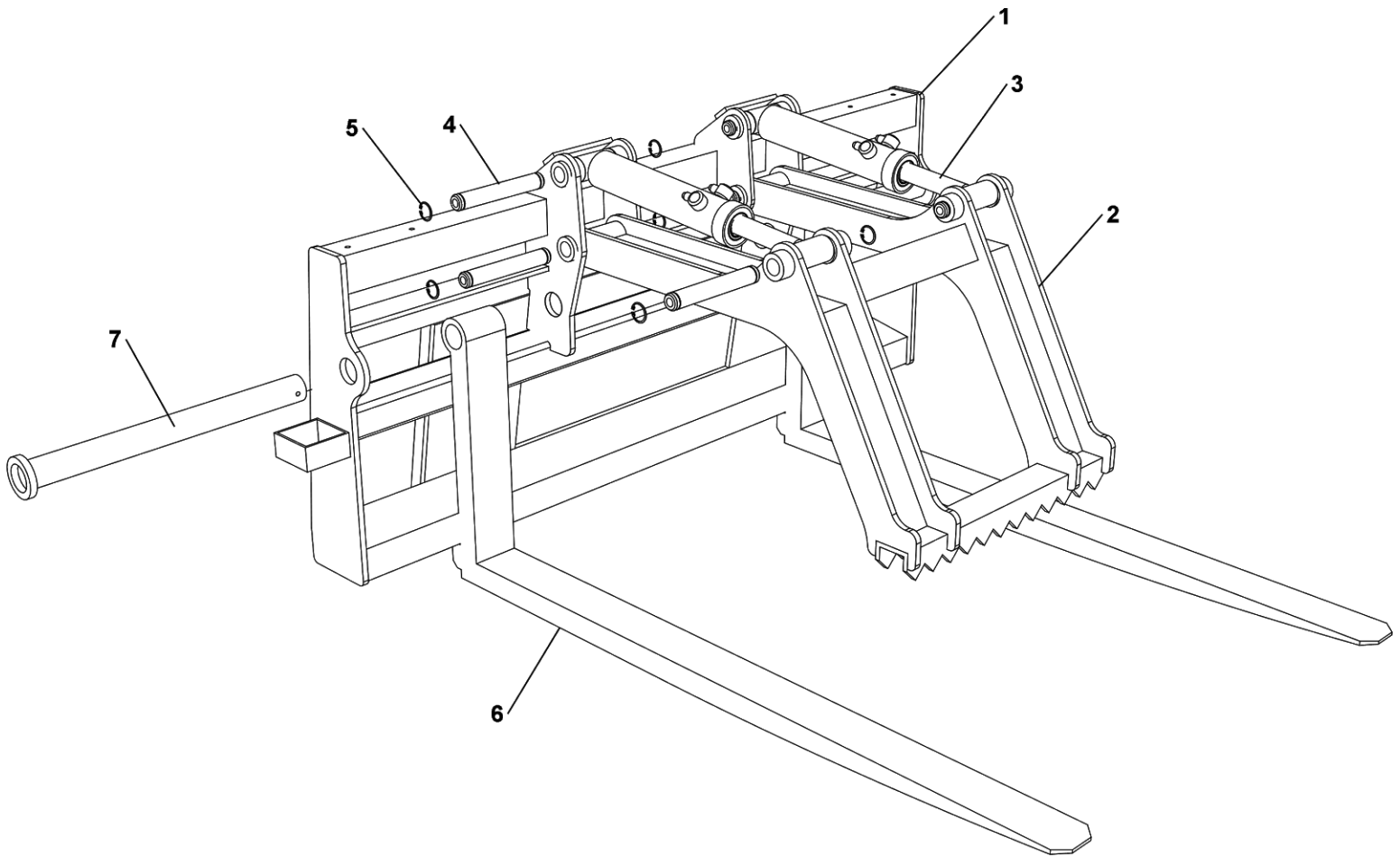

No.	Req'd	Part No.	Description
1	1	90056	66" Frame
2	1	90026	Grapple Arm
3	2	90193	Cylinder
4	6	90194	Cylinder Pin
5	12	90195	Snap Ring
6	2	90057	60" Tine – Shaft Style
7	2	90058	Shaft – Includes Bolt

Hydraulic Assembly

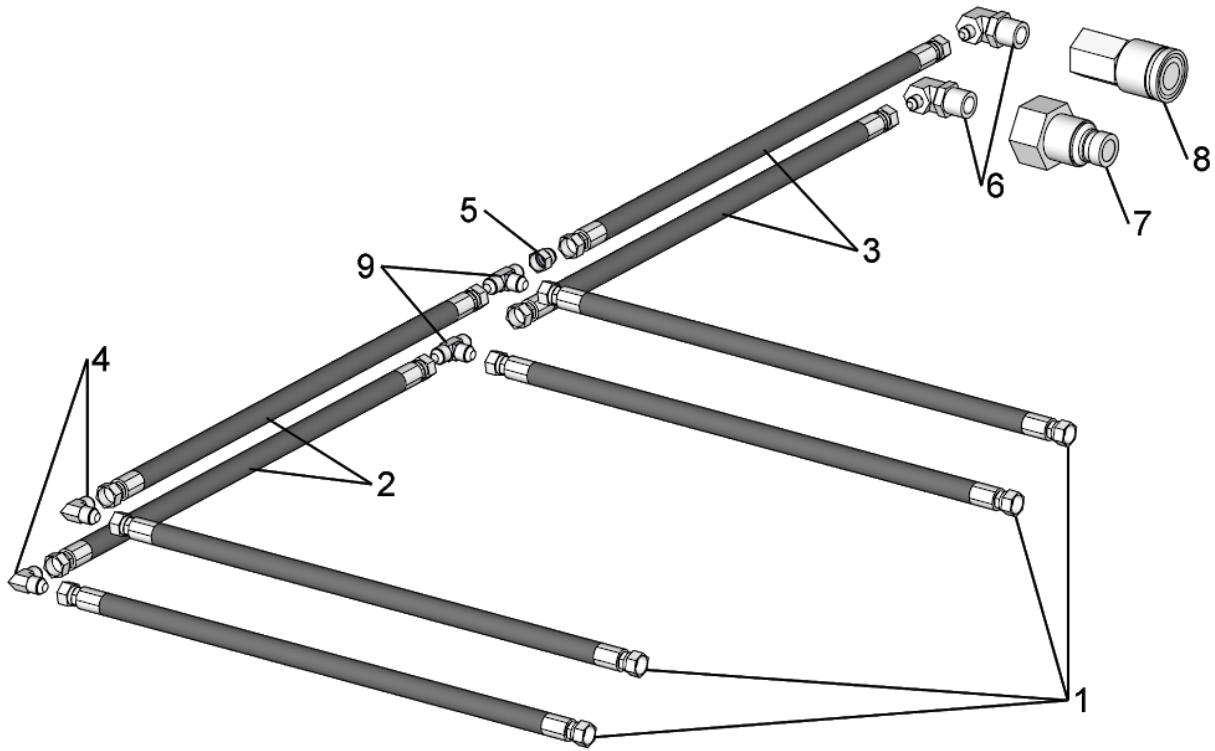

No.	Req'd	Part No.	Description
1	4	90181	Hose Assembly .38" x 20" 6FJ – 6FJ
2	2	90182	Hose Assembly .38" x 18" 6FJ – 6FJ
3	2	90183	Hose Assembly .38" x 108" 6FJ – 6FJ
4	2	90030	90° Elbow 6MJ – 6MJ
5	1	90031	Restrictor 6MJ – 6FJ
6	2	90032	90° Elbow 6MJ – 10MB
7	1	80133	Flat Face Male Coupler
8	1	80132	Flat Face Female Coupler
9	2	90033	Tee – 6MJ – 6MJ – 6MJ

Specifications

Model	MG60
Tine Length	60"
Tine Capacity (Pair)	6,600 lbs @ 24"
Overall Width	66.5"
Overall Depth	68.0"
Overall Height, Closed	34.0"
Overall Height, Open	46.2"
Overall Grapple Width	24.0"
Grapple Open	34.1"
Minimum Tine Spacing	30.0"
Maximum Tine Spacing	61.5"
Approximate Weight	970 lbs.
Max. Operating Pressure	3,500 PSI

Warranty

All new Talet products are warranted to be free from defects in materials or workmanship which may cause failure under normal usage and service when used for the purpose intended.

In the event of failure within twelve (12) months from initial retail sale, lease or rental date (excluding cable, ground engaging parts such as sprockets, digging chain, bearings, teeth, tamping and demolition heads, blade cutting edges, pilot bits, auger teeth, auger heads & broom bristles), if after examination, Talet determines failure was due to defective material and/or workmanship, parts will be repaired or replaced. Talet may request defective part or parts be returned prepaid to them for inspection at their place of business at Strathmore, Alberta or to a location specified by Talet.

Any claims under this warranty must be made within fifteen (15) days after the Buyer learns of the facts upon which such claim is based. All claims not made in writing and received by TALET within the time period specified above shall be deemed waived.

THIS WARRANTY IS IN LIEU OF ALL OTHER WARRANTIES EXPRESSED OR IMPLIED AND THERE ARE NO WARRANTIES OF MERCHANTABILITY OR OF FITNESS FOR A PARTICULAR PURPOSE. IN NO EVENT SHALL TALET BE LIABLE FOR CONSEQUENTIAL OR SPECIAL DAMAGE.

TALET'S LIABILITY FOR ANY AND ALL LOSSES AND DAMAGES TO BUYER, RESULTING FROM ANY CAUSE WHATSOEVER, INCLUDING TALET'S NEGLIGENCE, IRRESPECTIVE OF WHETHER SUCH DEFECTS ARE DISCOVERABLE OR LATENT, SHALL IN NO EVENT EXCEED THE PURCHASE PRICE OF THE PARTICULAR PRODUCTS WITH RESPECT TO WHICH LOSSES OR DAMAGES ARE CLAIMED, OR, AT THE ELECTION OF TALET, THE REPAIR OR REPLACEMENT OF DEFECTIVE OR DAMAGED PRODUCTS.