

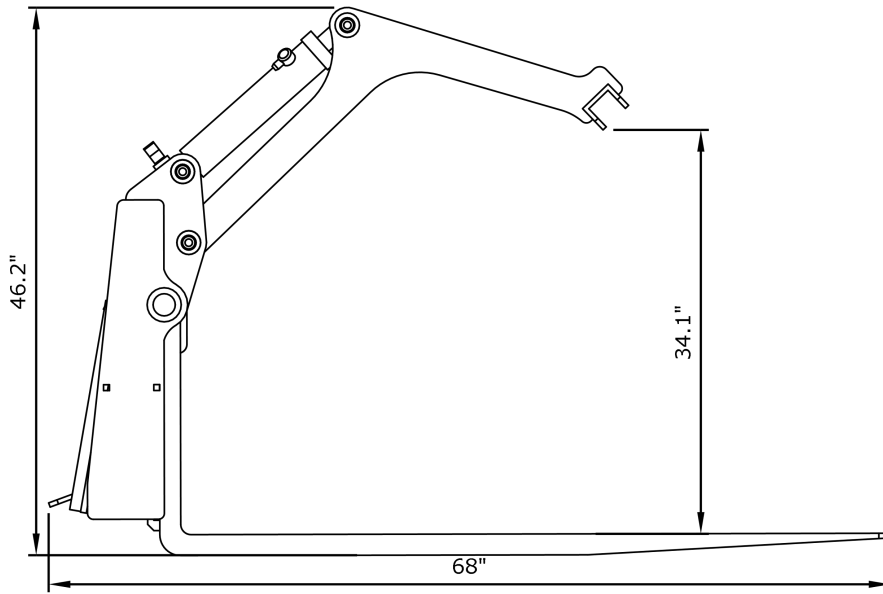

- Designed specifically for rig mats.
- 66" wide frame provides excellent stability.
- 60" - 6000 lb. heavy duty shaft style forks
- Dual 2.5" bore cylinders & 1.25" greasable pins.
- Reinforced grapple arms.
- Serrated tooth bar holds mats securely in place.



# Mat Grapple Specifications



Model	MG60
Tine Length	60"
Overall Width	66.5"
Overall Depth	68.0"
Overall Height, Closed	34.0"
Overall Height, Open	46.2"
Overall Grapple Width	24.0"
Grapple Open	34.1"
Minimum Tine Spacing	30.0"
Maximum Tine Spacing	61.5"
Capacity @ 24"	6,600 lbs.
Approximate Weight	970 lbs.
Max. Operating Pressure	3,500 PSI