

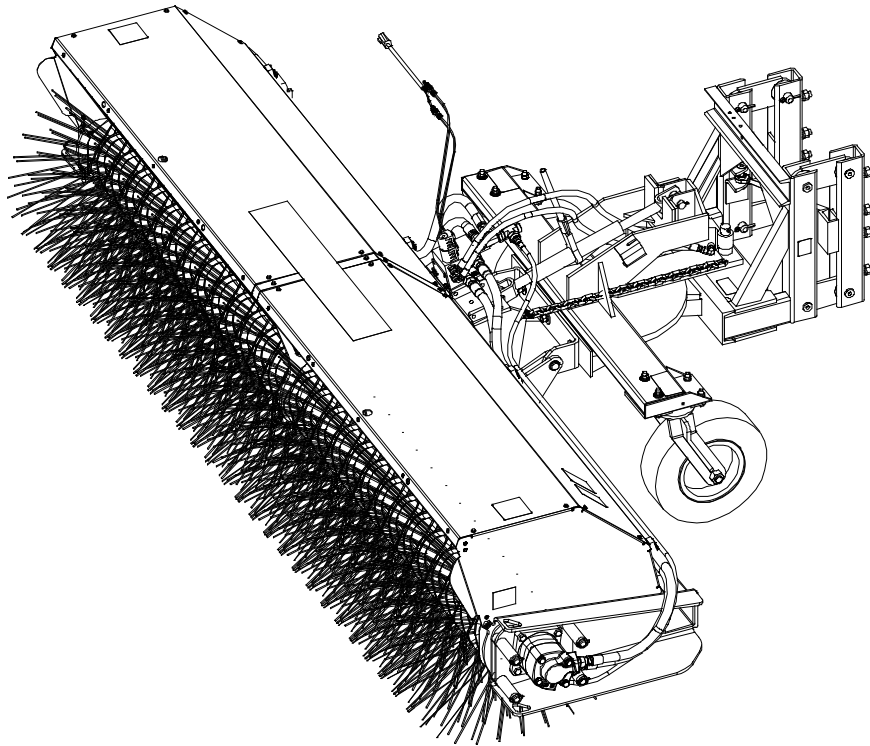

SWEEPSTER

BY PALADIN

OPERATOR'S AND PARTS MANUAL WLA 213 Series Hydraulic Windrow Sweeper for Loaders



Serial Number: _____

Model Number: _____

Manual Number: 51-4005

Release Date: January 2014

Serial Number: 0733001 & Up

Rev. 1

Table of Contents

Section 1 ... Installation.....	5-13
Section 2 ... Operation and Maintenance	15-22
Section 3 ... Service.....	23-33
Section 4 ... Parts.....	35-46
Section 5 ... Options	47-55
Section 6 ... Appendix	57-61

Installation Manual

Table of Contents

Introduction	6
Safety Information	7-13
General Safety Information	7-8
Safety Signs & Labels	10-11
Product Information Section.....	12
Installation/Storage	13

Introduction

Importance of this Manual



Read this manual before attempting to operate the equipment.

This operator's manual should be regarded as part of the sweeper. Suppliers of both new and secondhand sweepers are advised to keep documentation indicating that this manual was provided with the sweeper.

The manual contains information regarding installation, operation and maintenance required for this sweeper and optional equipment. It also includes detailed parts lists.

Purpose of Sweeper

This sweeper is designed solely for use in construction cleanup, road maintenance, grounds maintenance and similar operations. Use in any other way is considered contrary to the intended use. Compliance with and strict adherence to operation, service and repair conditions, as specified by the manufacturer, are also essential elements of the intended use.

This sweeper should be operated, serviced and repaired only by persons who are familiar with its characteristics and acquainted with relevant safety procedures.

Accident prevention regulations, all other generally recognized safety regulations and all road traffic regulations must be observed at all times.

Any modifications made to this sweeper may relieve the manufacturer of liability for any resulting damage or injury.

Safety Alert Symbol



This safety alert symbol indicates important safety messages in this manual. When you see this symbol, be alert to the possibility of injury. Carefully read the message that follows and inform other operators.

Contacting SWEEPSTER

If you have any questions about information in this manual or need to order parts, please call, write, fax or e-mail SWEEPSTER.

SWEEPSTER
2800 North Zeeb Road
Dexter, Michigan 48130
Phone: (734) 996-9116 - (800) 456-7100
FAX: (734) 996-9014
e-mail: sweepster@paladinbrands.com

For help with installation, operation or maintenance procedures, contact our Technical Service Department. Direct product questions and parts orders to our Sales Department.

When ordering parts or accessories, be prepared to give the following information:

- Sweeper model, serial number and date of purchase
- Prime mover, make and model
- Part number, description and quantity

Terms Used in Manual

Right-hand, left-hand, front and *rear* are determined from the operator's perspective (either the operator's seat or standing behind a walk-behind unit), facing forward in the normal operating position.

Prime mover refers to the tractor, truck, loader or tow vehicle that the sweeper is mounted on or towed by.

Optional Equipment

Installation instructions for optional equipment, if applicable, appear in the Service Manual Section.

Specifications & Features

Due to continuous product improvement, specifications and features may change without notice.

Warranty

To validate the warranty for this unit, fill out the warranty card or warranty pages located at the back of this manual. Then, send this information to SWEEPSTER.

Safety Information

Read this manual

Read all safety information in this manual. All operators must read and understand the entire contents of this manual before sweeping. General safety practices are listed on Safety Information pages and specific safety information is located throughout this manual.

Hazard Definitions

Four hazard classifications are used in this manual. They are



DANGER - Indicates an imminently hazardous situation which, if not avoided, will result in death or serious injury.



WARNING - Indicates a potentially hazardous situation which, if not avoided, could result in death or serious injury.



CAUTION - Indicates a potentially hazardous situation which, if not avoided, may result in minor or moderate injury.

NOTICE - Used for instructions when machine damage may be involved.

Operation



CAUTION - A sweeper is a demanding machine. Only fully trained operators or trainee operators under the close supervision of a fully trained person should use this machine.

Before operating sweeper:

- Learn sweeper and prime mover controls in an off-road location.
- Be sure that you are in a safe area, away from traffic or other hazards.
- Check all hardware holding the sweeper to the prime mover, making sure it is tight.
- Replace any damaged or fatigued hardware with properly rated fasteners. See Maintenance Section
- Make sure all hydraulic hardware and hydraulic fittings are tight.
- Replace any damaged or fatigued fittings or hoses.

- Check prime mover tire pressure before sweeping.
- Check tire ratings to be sure they match the prime mover load. Weigh the sweeper end of the prime mover, if necessary, to insure proper tire rating.
- Remove from the sweeping area all property that could be damaged by flying debris.
- Be sure all persons not operating the sweeper are clear of the sweeper discharge area.
- Always wear proper apparel such as a long-sleeved shirt buttoned at the cuffs; safety glasses, goggles or a face shield; ear protection; and a dust mask.

While operating sweeper:

- When operating sweeper, adhere to all government rules, local laws and other professional guidelines for your sweeping application.



WARNING - Never raise the sweeper more than a few feet off the ground. The sweeper can tip back or the prime mover can tip over causing death or serious injury,

- Before leaving the operator's area for any reason, lower the sweeper to the ground. Stop the prime mover engine, set the parking brake and remove the key from the ignition.
- Minimize flying debris - use the slowest rotating speed that will do the job. See Operation Section: Operating Tips
- Keep hands, feet, hair and loose clothing away from all moving parts.
- Leave the brush hood (shield) and all other shields and safety equipment in place when operating the sweeper and prime mover.
- Be aware of the extra weight and width a sweeper adds. Reduce travel speed accordingly. See Product Information Section: Operating the Sweeper.
- When sweeping on rough terrain, reduce speed to avoid "bouncing" the sweeper. Loss of steering can result.
- Never sweep toward people, buildings, vehicles or other objects that can be damaged by flying debris.
- Only operate the sweeper while you are in the operating position. The safety restraint must be fastened while you operate the prime mover. Only operate the controls while the engine is running. Protective glasses must be worn while you operate the prime mover and while you operate the sweeper.
- While you operate the sweeper slowly in an open area, check for proper operation of all controls and all protective devices. Note any needed repairs during operation of the sweeper. Report any needed repairs.

SAFETY SECTION
GENERAL SAFETY INFORMATION

Service & Repair - General



CAUTION - Do not modify the sweeper in any way. Personal injury could result. If you have questions, contact your dealer or SWEEPSTER.

Repair or adjust the sweeper in a safe area, away from traffic and other hazards.

Before adjusting or servicing - lower the sweeper to the ground, set parking brake, shut down the prime mover and remove the key from the ignition.

When working on or around the sweeper, safely secure it from falling or shifting.

Service & Repair - Hydraulic Safety

Stop the prime mover engine and release hydraulic pressure before servicing or adjusting sweeper hydraulic systems.



WARNING - Escaping hydraulic fluid can have enough pressure to penetrate the skin, causing serious personal injury.

Check lines, tubes and hoses carefully. Do not use your hand to check for leaks. Use a board or cardboard to check for leaks. Tighten all connections to the recommended torque. See Appendix.

Do not bend high pressure lines. Do not strike high pressure lines, Do not install bent lines, bent tubes, or kinked hoses. Do not install damaged lines, damaged tubes, or damaged hoses.

Repair loose lines, loose tubes, and loose hoses. Repair damaged lines, damaged tubes, and damaged hoses. Leaks can cause fires. See your SWEEPSTER dealer for repair or replacement parts.

Replace the parts if any of the following conditions are present:

- The end fittings are damaged or leaking.
- The outer covering is chafed or cut.
- The reinforcing wire layer is exposed.
- The outer covering is ballooning locally.
- The hose is kinked or crushed.
- The hoses have been pulled or stretched.

Make sure that all clamps, guards, and shields are installed correctly.

WARNING!



EXPOSURE TO RESPIRABLE CRYSTALLINE SILICA DUST ALONG WITH OTHER HAZARDOUS DUSTS MAY CAUSE SERIOUS OR FATAL RESPIRATORY DISEASE.

It is recommended to use dust suppression, dust collection and if necessary personal protective equipment during the operation of any attachment that may cause high levels of dust.

WARNING!



REMOVE PAINT BEFORE WELDING OR HEATING.

Hazardous fumes/dust can be generated when paint is heated by welding, soldering or using a torch. Do all work outside or in a well ventilated area and dispose of paint and solvent properly. Remove paint before welding or heating.

When sanding or grinding paint, avoid breathing the dust. Wear an approved respirator. If you use solvent or paint stripper, remove stripper with soap and water before welding. Remove solvent or paint stripper containers and other flammable material from area. Allow fumes to disperse at least 15 minutes before welding or heating.

Notes

SAFETY SECTION
SAFETY SIGNS & LABELS

Safety Signs and Labels

There are several specific safety signs on this sweeper. The exact location of the hazards and the description of the hazards are reviewed in this section.

Placement or Replacement of Safety Signs

1. Clean the area of application with nonflammable solvent, and then wash the same area with soap and water.
2. Allow the surface to fully dry.
3. Remove the backing from the safety sign, exposing the adhesive surface.
4. Apply the safety sign to the position shown in the diagram above and smooth out any bubbles.

Instructions

- Keep all safety signs clean and legible.
- Replace all missing, illegible, or damaged safety signs.
- Replacement parts, for parts with safety signs attached, must also have safety signs attached.
- Safety signs are available, free of charge, from your dealer or from SWEEPSTER.

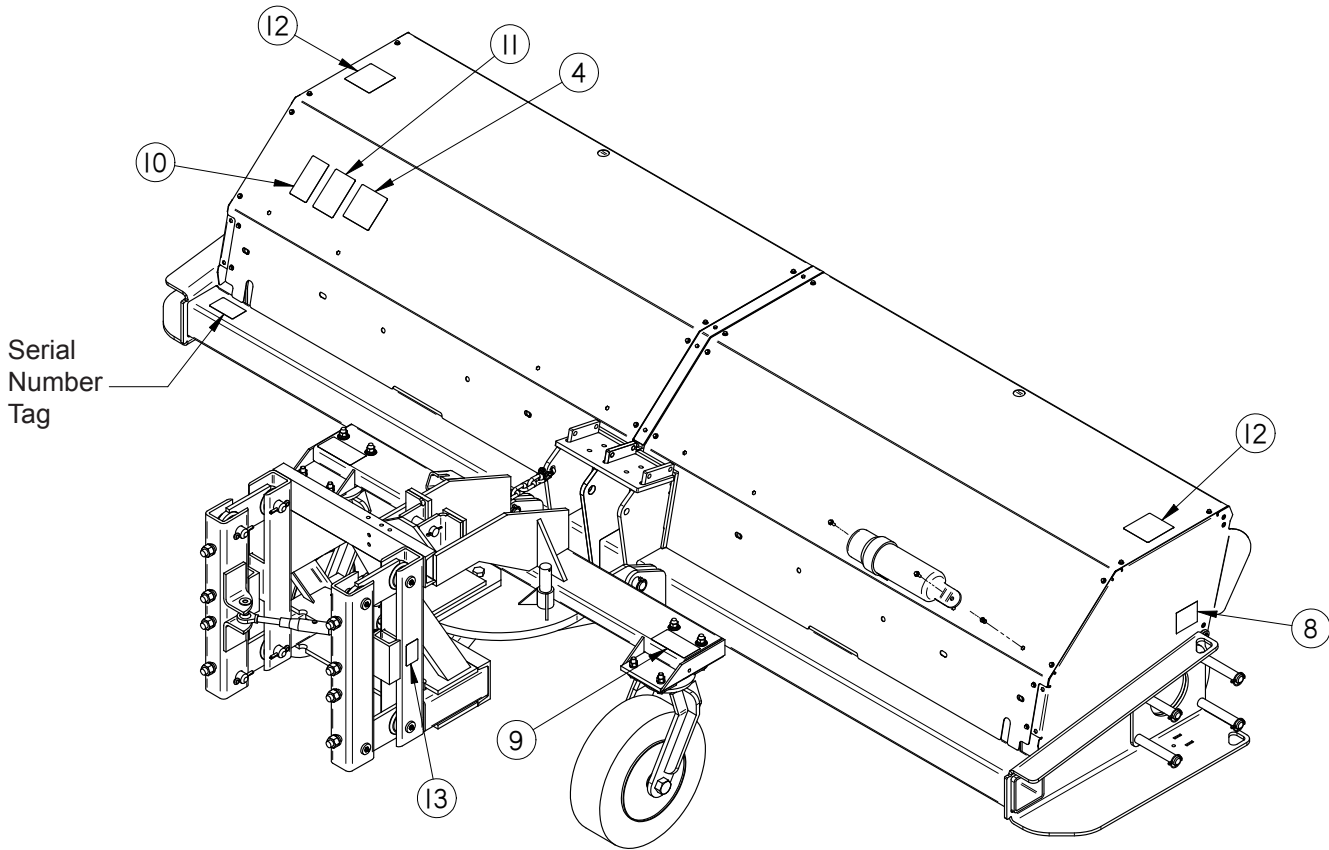

Item	Part	Qty	Description
4.	41043	1	Decal, Warning, Hazardous Dust
8.	50-0643	2	Label, Tie Down Point
9.	50-0721	2	Label, Warning, Crush Hazard
10.	50-0722	1	Label, Warning, Misuse Hazard
11.	50-0724	1	Label, Warning, High Pressure Fluid Hazard
12.	50-0726	2	Label, Warning, Flying Objects & Entanglement
13.	50-0775	2	Label, Warning, Crush Hazard Vertical

Safety Signs and Labels



4. 41043

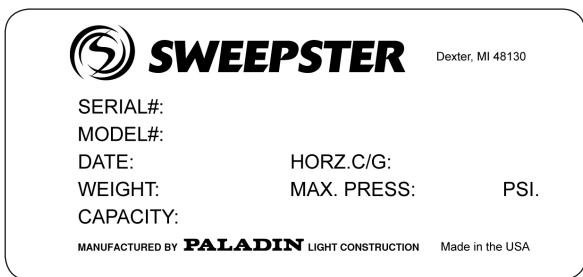

Serial Number Tag

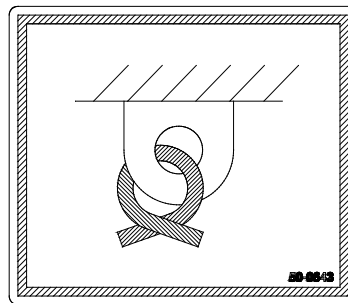

8. 50-0643

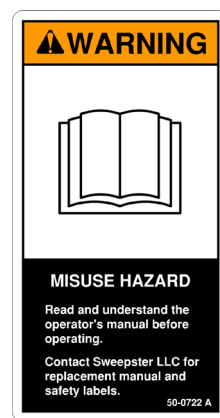

10. 50-0722

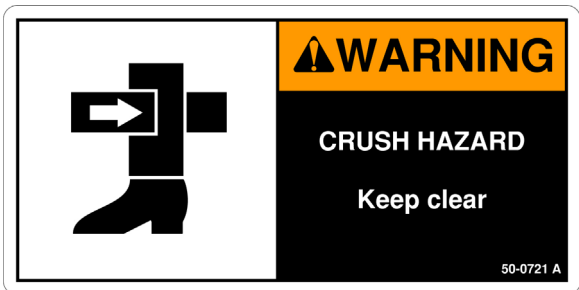

9. 50-0721



12. 50-0726



11. 50-0724



13. 50-0775

Product Information Section

Specifications and Model Views

Maximum Width at 0° Articulation

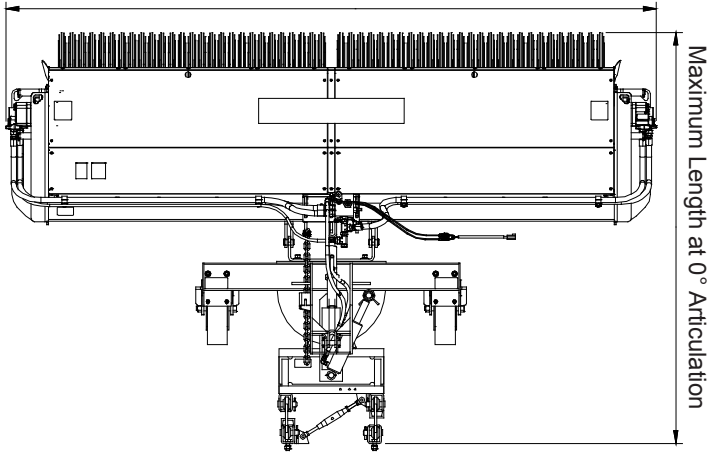

Maximum Length at 0° Articulation

Maximum Width at Full Articulation

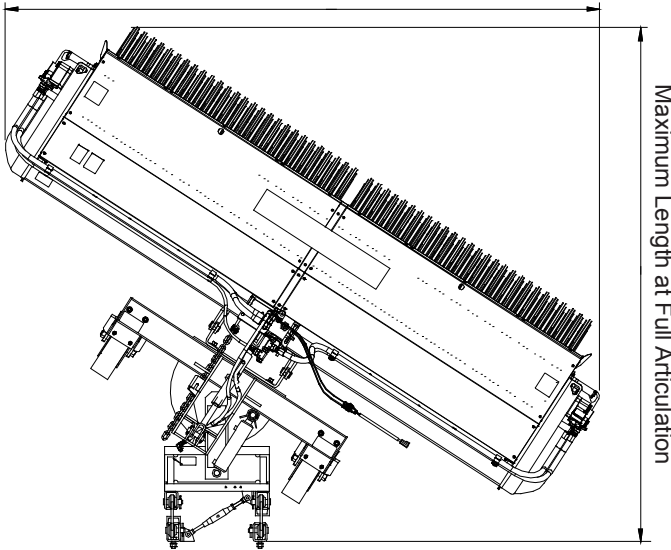

Maximum Length at Full Articulation

QC Brush Head		
Approximate Weight with Mounting/Swing (Hook Set Not Included)	1977 lbs	10 Ft
	2232 lbs	12 Ft
Maximum Length at 0° Articulation	90.2 inches	
Maximum Width at 0° Articulation	142.7 inches	10 Ft
	166.7 inches	12 Ft
Maximum Length at Full Articulation	112.8 inches	10 Ft
	119.3 inches	12 Ft
Maximum Width at Full Articulation	130.5 inches	10 Ft
	150.7 inches	12 Ft
Sweeping Width at 0° Articulation	120 inches	10 Ft
	144 inches	12 Ft
Sweeping Width at Full Articulation	103 inches	10 Ft
	124 inches	12 Ft

Range of Hydraulic Oil Flow and Pressure			
Dual Motor	11.9 CI	12-30 gpm	4500 max psi
Dual Motor	11.9/23.9 CI	18-45 gpm	4000 max psi
Dual Motor	23.9 CI	24-60 gpm	4000 max psi

Maximum Allowable Back Pressure
750psi @ 250rpm
Over 750psi - case drain required

Sweeper Installation (Broom to Prime Mover)



WARNING - Improper attachment of sweeper could result in injury or death. Do not operate this machine until you have positive indication that the attachment is securely mounted.

1. Position the broom on a level surface.
2. Enter the prime mover.
3. Fasten the safety restraints.
4. Start the engine.
5. Disengage the parking brake.
6. Align the attachment mechanism with the mounting on the broom, attach to the prime mover. Follow the attaching procedure in the prime mover owners manual.
7. Engage the parking brake and shut down the prime mover. Be sure to relieve pressure to the auxiliary hydraulic lines.
8. Unfasten safety restraints and exit the prime mover.
9. Lock jack stands in stowed position. (if available)
10. Ensure that the hydraulic quick couplers are clean. Connect hydraulic lines for the broom to the prime mover. Twist the collar of the quick couplers one quarter of a turn in order to secure the hydraulic connections.
11. While the loader arms are lowered, visually inspect the attachment mechanism to ensure that it is securely mounted.
12. Enter prime mover, fasten safety restraints and start the prime mover.
13. Carefully raise the loader and cycle the rollback/dump cylinders to check clearances, that limiting stops make proper contact and verify that all mounting procedures have been successfully completed. Contact SWEEPSTER for instructions if the limiting stops do not contact properly.

Removing the Sweeper



WARNING - Serious injury or death may result from disengaging the sweeper when the sweeper is in an unstable position or carrying a load. Place the sweeper in a stable position before disengaging.

NOTICE - Hoses for the sweepers must be removed before the quick attach is disengaged. Pulling the sweeper with the hoses could result in damage to the prime mover or the sweeper.

1. Lower the broom to the ground.
2. Engage the parking brake and shut down the prime mover. Be sure to relieve pressure to the auxiliary hydraulic lines.
3. Unfasten safety restraints and exit prime mover.
4. Lock jack stands in lowered position. (if available)
5. Disconnect the broom hydraulic lines from the prime mover. Connect quick couplers together to keep clean.
6. Disengage attachment locking mechanism. (mechanical type)
7. Enter prime mover, fasten safety restraints and start the prime mover.
8. Disengage attachment mechanism. (hydraulic type)
9. Disengage the parking brake, and back away from the broom.

Storage

NOTICE - Do not store the sweeper with weight on the brush. Weight will deform the bristles, destroying the sweeping effectiveness. To avoid this problem, place the sweeper on blocks or use storage stands.

Do not store polypropylene brushes in direct sunlight. The material can deteriorate and crumble before the bristles are worn out.

Keep polypropylene brush material away from intense heat or flame.

Notes

Operation and Maintenance Manual

Table of Contents

Operation.....	16-17
Operation	16
Leveling Sweeper	17
Maintenance.....	18-22
Brush Pattern Adjustment	18
Maintenance Schedule	19
Maintenance Record.....	20
Replacing Brush Sections.....	21
Lubrication Points	22

OPERATION SECTION

SWEEPING/OPERATING TIPS

Before Each Use

Perform daily maintenance as indicated in Maintenance Schedule.

Run the prime mover and sweeper at a slow idle. Check for hydraulic leaks or other problems and make corrections, if necessary, before using the sweeper. See "Hydraulic inspection guideline".



WARNING - Avoid serious injury. Check for large objects that could harm the operator or others if thrown by the sweeper. Remove these items before operating.

During Use

Directing Debris

Carry the sweeper low to the ground so that the operator has good visibility and stability. Avoid any sudden movements.

Avoid excessive downward pressure on the brush sections to prevent excessive wear. A two to four inch wide pattern is sufficient for most applications. Ensure that the adjustment bolts are equally adjusted in order to prevent an uneven wear pattern. To adjust brush pattern see "Adjusting Brush Pattern".

Direct debris by angling the brush head in that direction.

Observe wind direction. Sweeping with the wind makes sweeping more effective and helps keep debris off the operator.

The terms *swing* and *angle* are used interchangeably.

Manual Angle

1. Remove the lock pin from links.
2. Position the brush head at the desired angle, aligning holes in the inner and outer link.
3. Insert and close the lock pin.

Hydraulic Angle

1. Start the prime mover.
2. Position the brush head at the desired angle by using the valve control for the swing function.

Sweeping

To sweep:

1. Manual angle only - Swing the brush head assembly the direction that you want to direct debris.
2. Start the prime mover at idle and raise the brush.
3. Hydraulic angle only - Swing the brush head assembly the direction that you want to direct debris.

4. Engage the brush and then lower it to the ground.
5. Increase prime mover engine rpm to sweeping speed.
6. Travel forward at 5 mph (8 kph) or less.

NOTICE - Avoid sweeper damage. Reduce travel speed to avoid hitting immovable objects.

Operating Tips

NOTICE - Avoid sweeper damage. Do not ram into piles. Use an appropriate attachment for this type of job.

Brush, Engine & Travel Speeds

Vary brush, engine and travel speeds to match sweeping conditions.

Large Areas

When sweeping a large area, such as a parking lot, make a path down the middle and sweep to both sides. This reduces the amount of debris that the sweeper must sweep to one side.

Snow

Fast brush speeds and slow travel speeds are needed to sweep snow effectively. Start at 3/4 throttle and the lowest gear of the prime mover. For wet and/or deep snow, increase to almost full throttle. This helps keep snow from packing up inside the brush hood.

In deep snow you may need to make multiple passes to get down to a clean surface.

To keep snow from blowing back onto a swept area, always sweep so the wind is at your back.

Dirt & Gravel

To keep dust at a minimum, use the optional dust suppression kit or plan sweeping for days when it is overcast and humid or after it has rained. Also, sweep so the wind blows at your back.

Low brush speeds and moderate travel speeds work best for cleaning debris from hard surfaces. Brush speeds that are too fast tend to raise dust because of the aggressive sweeper action.

To sweep gravel, use just enough brush speed to "roll" the gravel, not throw it.

Heavy Debris

Travel slowly - 2-3 mph. (3-5 kph)

Sweep a path less than the full width of the sweeper.

Increase engine speed if debris becomes very heavy.

Aligning Mounting

The mounting incorporates a four-bar linkage system that allows the sweeper to move up and down independently of the loader arms. This feature is very important because it permits the sweeper to follow the contours of the ground, offering a good sweep.

NOTICE - Adjust the four-bar linkage before each operation to avoid sweeper damage.

Sweeping with a properly adjusted mounting offers efficient performance, while using the mounting out of adjustment can cause severe damage to the sweeper and can result in a poor sweep. If the U-channels on the loader arms are positioned too low, the sweeper must support the loader arms, an amount of weight far greater than the sweeper is designed to carry. If the U-channels on the loader arms are too high, the sweeper cannot sweep into the low areas.

To adjust the mounting:

1. Drive the loader and sweeper to a flat surface.
2. Lower the sweeper so the casters sit on the ground.
3. Adjust the loader arms so the tops of the U-channels on the sweeper and the tops of the U-channels on the loader arms are even (figure 1).
4. Adjust the brush height according to Setting Brush Pattern.

Leveling

Level the sweeper for even brush wear and effective use.



CAUTION - Avoid injury. Before adjusting the sweeper, always turn off the sweeper and the prime mover engine and remove the key.

1. Move the sweeper to a flat, paved surface.
2. Lower the brush head assembly to the ground.
3. Position the brush head assembly straight ahead.
4. Engage the parking brake and shut down the prime mover. Be sure to relieve pressure to the auxiliary hydraulic lines.
5. Unfasten safety restraints and exit prime mover.
6. On each side, measure from the brush frame to the ground (figure 2). If measurements are not equal:

Loosen hardware that attaches the swing assembly to the brush head assembly; lower the high side of the brush head until both sides are an equal distance above the ground. Tighten the hardware. (figure 3)

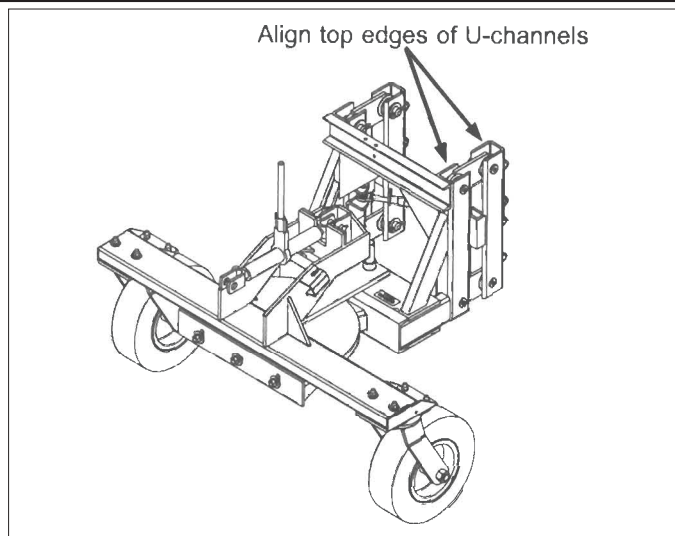

figure 1

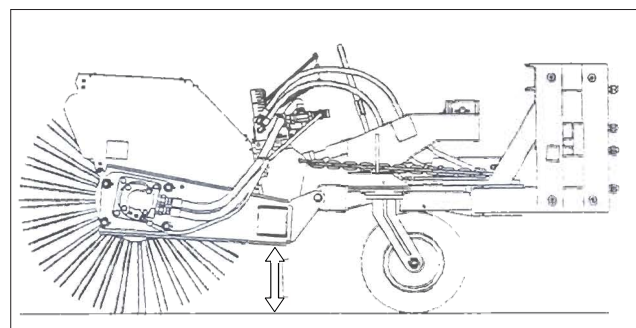

figure 2

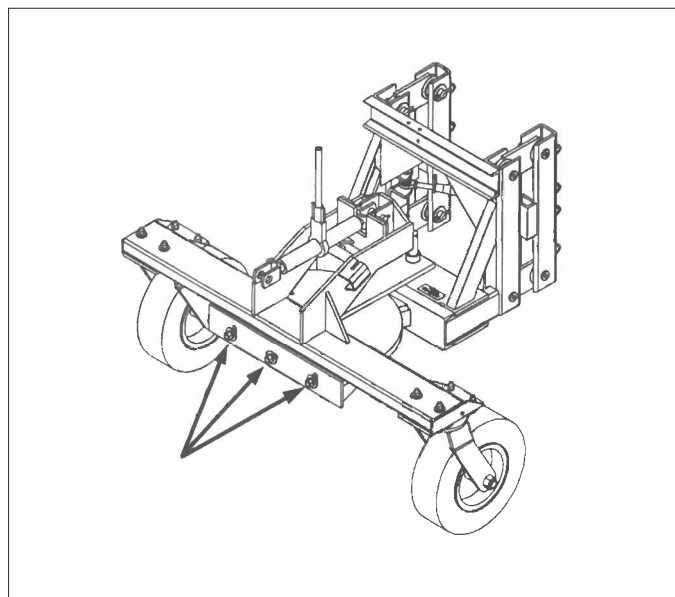

figure 3

Setting Brush Pattern

A properly adjusted brush offers the best sweeper performance. To check the brush pattern:

1. Move the sweeper to a dusty, flat surface.
2. Engage the parking brake and shut down the prime mover. Be sure to relieve pressure to the auxiliary hydraulic lines.
3. Ratchet the brush head down until the bristles touch the ground.
4. Start the sweeper at a slow speed. Run the sweeper in a stationary position for 10 seconds.
5. Raise the sweeper and back away; switch off the engine and remove the key. The brush pattern left in the dust should be 2-4 inches (51-102 mm) wide, running the length of the brush. (Compare the swept area with figure 7.)
6. Adjust the brush pattern as necessary using the adjusting ratchet.

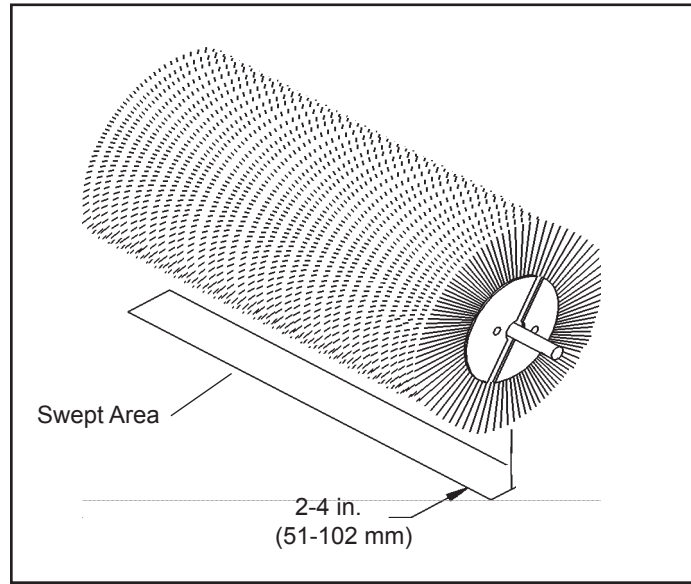

Figure 7

MAINTENANCE SECTION
MAINTENANCE SCHEDULE

Maintenance Schedule

Procedure	Before Each Use	After Each Use	100 Hours	500 Hours	See Prime Mover
Brush head assembly - Level	✓				
Brush pattern - Check (See Pattern Adj. Section)	✓				
Cylinders - Retract rods		✓			
- Grease threaded and ball ends to prevent rust		✓			
Filter, air, prime mover - Clean	✓				✓
Fittings/hoses, hydraulic - Check for leaks/tighten Check for damage	✓				
Fittings, zerk - Grease. (See lubrication points)	✓				
Oil, hydraulic - Check Level	✓				
Hardware - Check for tightness	✓				

MAINTENANCE SECTION
REPLACING BRUSH SECTIONS

1. Remove lynch pins and bushings. Retain hardware for reinstallation. Remove motor.
2. Remove core from brush head assembly.
3. Remove lynch pins, bushings and motor from the other side of brush head.
4. Remove idler bearing shaft mounting plate, retaining hardware.
5. Remove second core from brush head assembly.
6. Remove old sections.
7. Install new sections by doing the following:
 - a. Slide the first section onto the core with the drive pins on each side of a tube. Make sure that the drive pins angle up. (figure 1)
 - b. Install a second section with drive pins rotated 180° from those on the first section. (figure 2)
 - c. Continue installing sections, rotating each section 180° until the core is full.
8. Re-attach the section retainer with previously removed hardware.
9. Lay cores on ground. Lower frame over cores.
10. Re-attach idler bearing mounting plate with previously removed hardware.
11. Re-attach motors with lynch pins and bushings.

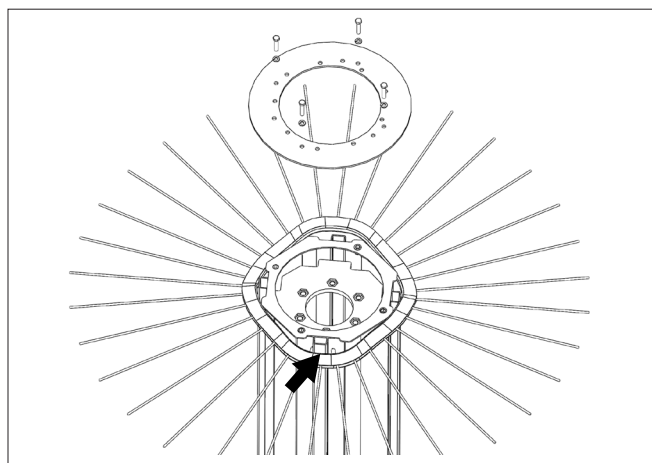

figure 1

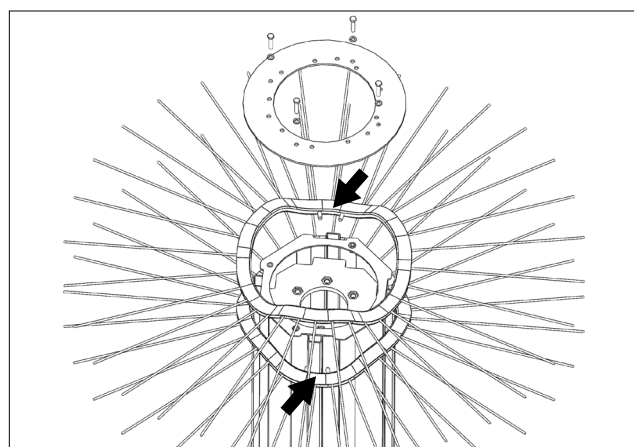
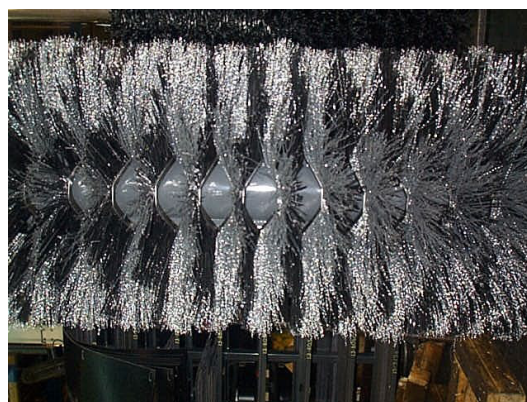

figure 2



Worn Section Standard				Reference Information	
Section OD, New	Ring ID	Section OD, Worn	Exposed Bristle, Worn	Bristle Length	Exposed Bristle, New
24	6.38	17	3.8	8.50	7.5
26	8.00	18	4.0	9.00	8.0
32	10.00	22	5.0	11.00	10.0
36	10.00	24	6.0	13.00	12.0
36	10.63	25	6.0	12.69	11.4
46	19.38	34	6.0	13.31	12.1

Lubrication Points

The following grease fittings should be greased before each use. See figure for locations.

1. Parallel Link Pins (8 fittings)
2. Caster Assembly (2 fittings)
3. Hydraulic Angle Cylinder (1 fitting)

Not Shown:
Center Mounted (1 fitting)

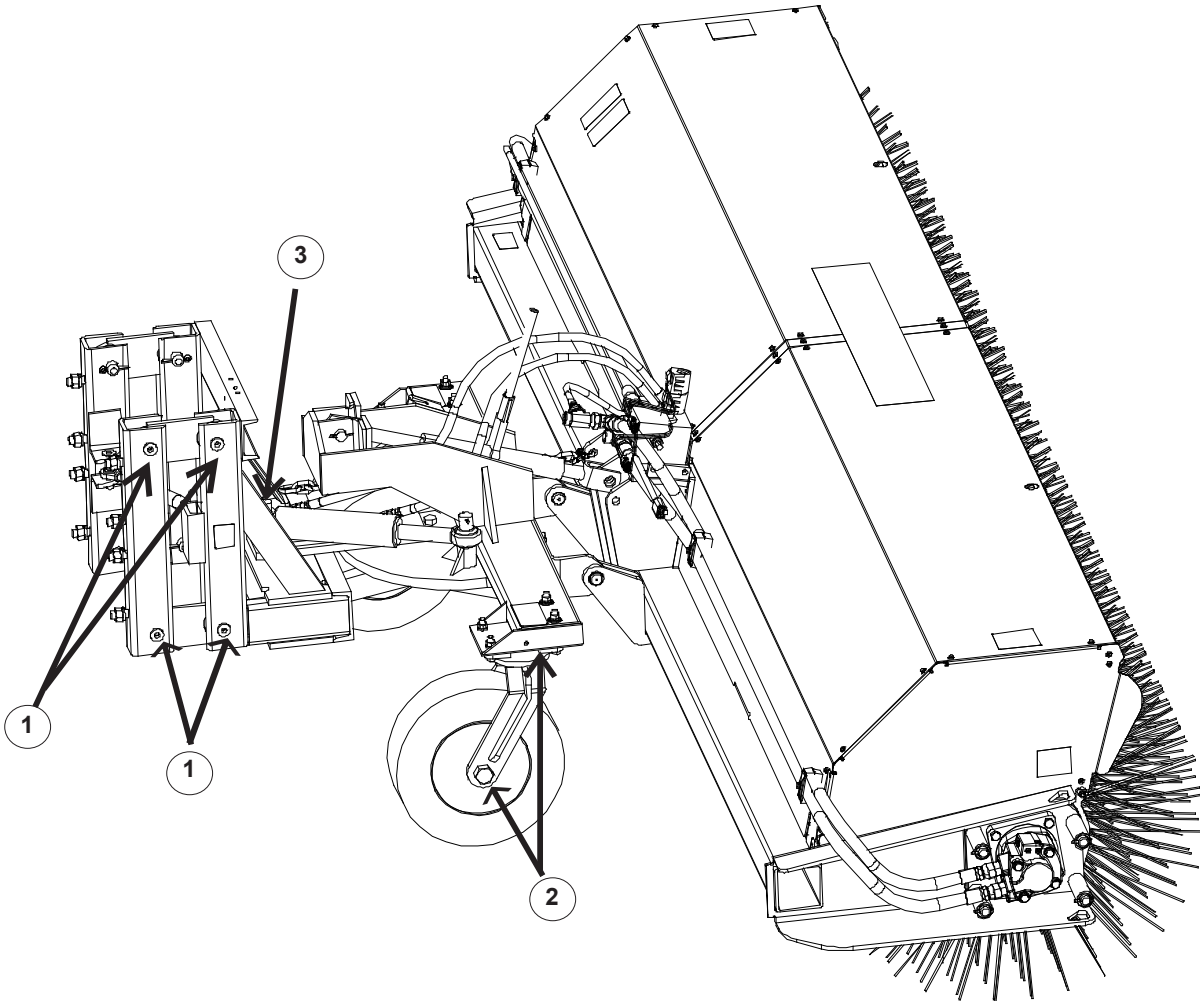

Service Manual

Table of Contents

Troubleshooting	23-33
Brush Head.....	24
Lift & Swing.....	25
Hydraulic System.....	26-29
Wiring Harness	30--33

SERVICE SECTION
TROUBLESHOOTING

Brush Head

Problem	Possible Cause	Possible Solution
Brush rotates wrong direction	Hoses installed incorrectly	Switch hoses at brush head tubes
Brush slows or stops when sweeping	Brush pattern too wide	Adjust brush pattern to 2-4 inches (51-101mm) wide: see Maintenance: Adjusting Brush Pattern
	Travel speed too fast	Travel no more than 5 mph (8 kph) while sweeping (2-3 mph recommended)
	Trying to sweep too much material at once	Make several passes with sweeper
	Relief pressure set too low	Set relief pressure to 2000 psi (138.0 bars)
	Filter plugging	Change or clean filter
Brush wears into cone shape	Tires on prime mover at different pressures or are different sizes	Check tire sizes and ratings: make corrections as necessary
Brush wears very quickly	Brush pattern too wide	Adjust brush pattern to 2-4 inches (51-101mm) wide: see Maintenance: Setting Brush Pattern

Hydraulic Cylinders - Lift & Swing

Problem	Possible Cause	Possible Solution
Hydraulic cylinder neither extends nor retracts	No power from controls because wires are broken or disconnected	Reconnect wires if disconnected; replace wires if broken
	No power from controls because switch is broken	Replace switch
	Hoses or fittings loose or disconnected	Tighten hoses or fittings
	Restriction in hoses	Remove bends in hoses, remove obstructions inside hoses
Hydraulic cylinder only extends or only retracts	Dirt or debris in spools	Contact Sweepster Technical Service

SERVICE SECTION
TROUBLESHOOTING

Hydraulic System

Problem	Possible Cause	Possible Solution
Hydraulic system overheats	Restriction in hoses	Remove bends in hoses; remove obstructions inside hoses
	Host pump flow rate exceeds maximum rate of broom	Contact host manufacturer for proper flow control method
Hydraulic motor seals leak	Back pressure exceeds 1000psi	Contact Sweepster
	Motor is failing	High number of hours on motor; Contact dealer to rebuild or replace

Motor Port Identification

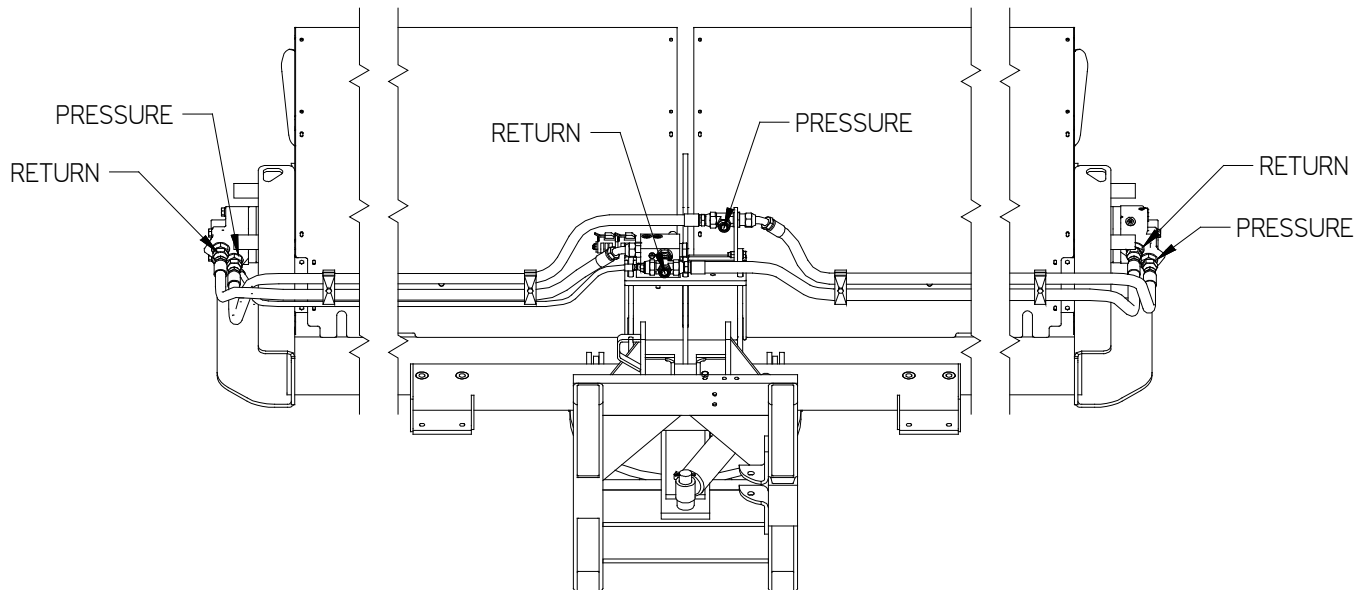

03-5215
12 Volt Manifold

Hydraulic Schematic

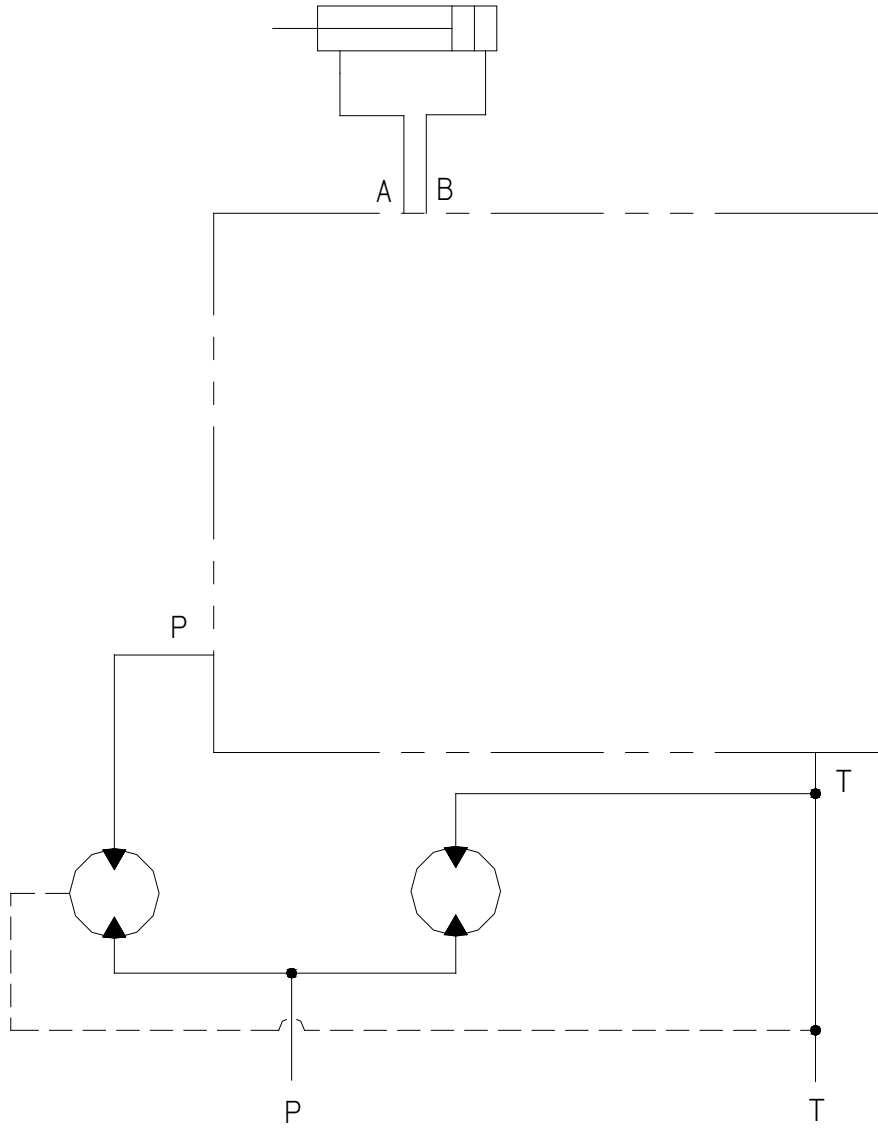

03-5836
24 Volt Manifold

Hydraulic Schematic

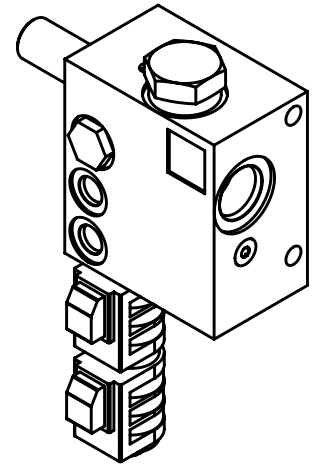
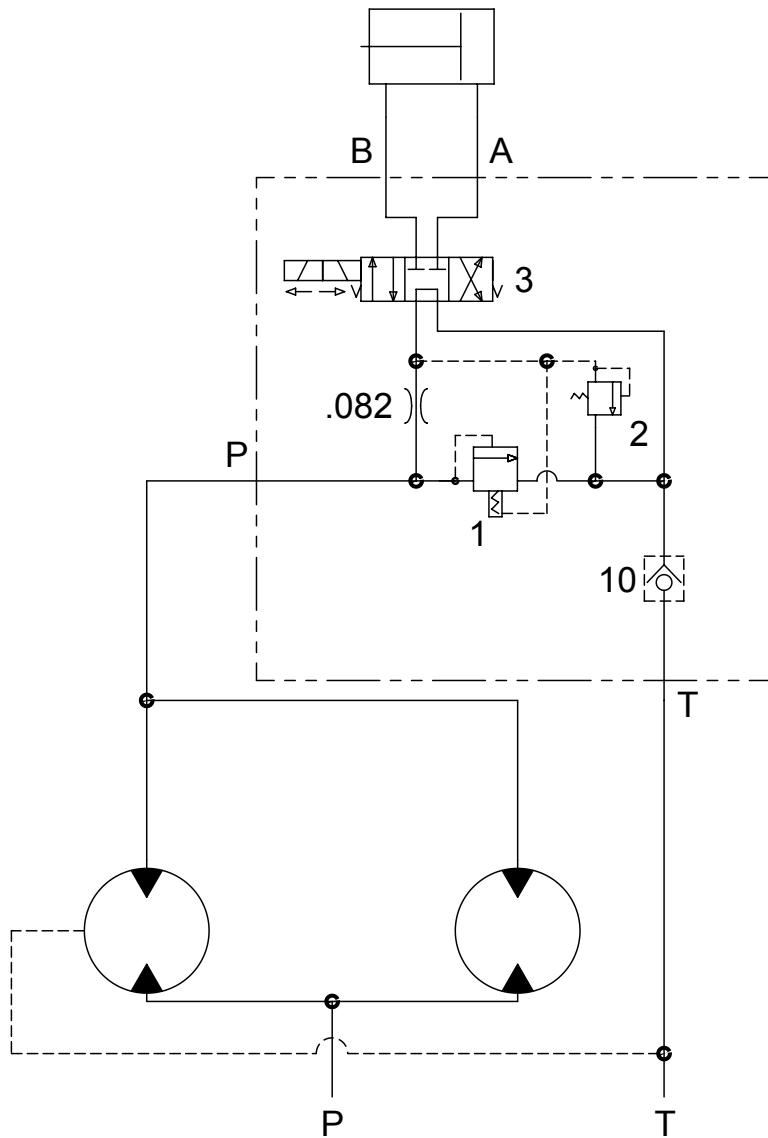

SERVICE SECTION
TROUBLESHOOTING

Wiring Harness

LAF9444 WIRE HARNESS

WIRE NO.	GAUGE	IDENTIFICATION		APPLICATION	
		FROM	TO	FROM	TO
1A	16	BLACK	BATTERY -12V	SPADE TERMINAL (MALE)	
1B	16	BLACK	PACKARD CONN. PIN F	SPADE TERMINAL (FEMALE)	
2A	16	RED	BATTERY +	CIRCUIT BREAKER 10A - BATT	
2B	16	RED	CIRCUIT BREAKER 10A - AUX	SWITCH 1-A	
3	16	RED	PACKARD CONN. PIN B-DEPT H	SWITCH 1-B	
4	16	YELLOW	PACKARD CONN. PIN C-TILT	SWITCH 1-C	

- | Item | Part | Qty | Description |
|------|---------|-----|-----------------|
| 1. | 07-3152 | 1 | Circuit Breaker |
| 2. | 07-0868 | 1 | Switch |
| 3. | 07-1824 | 1 | Rubber Boot |

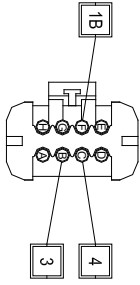
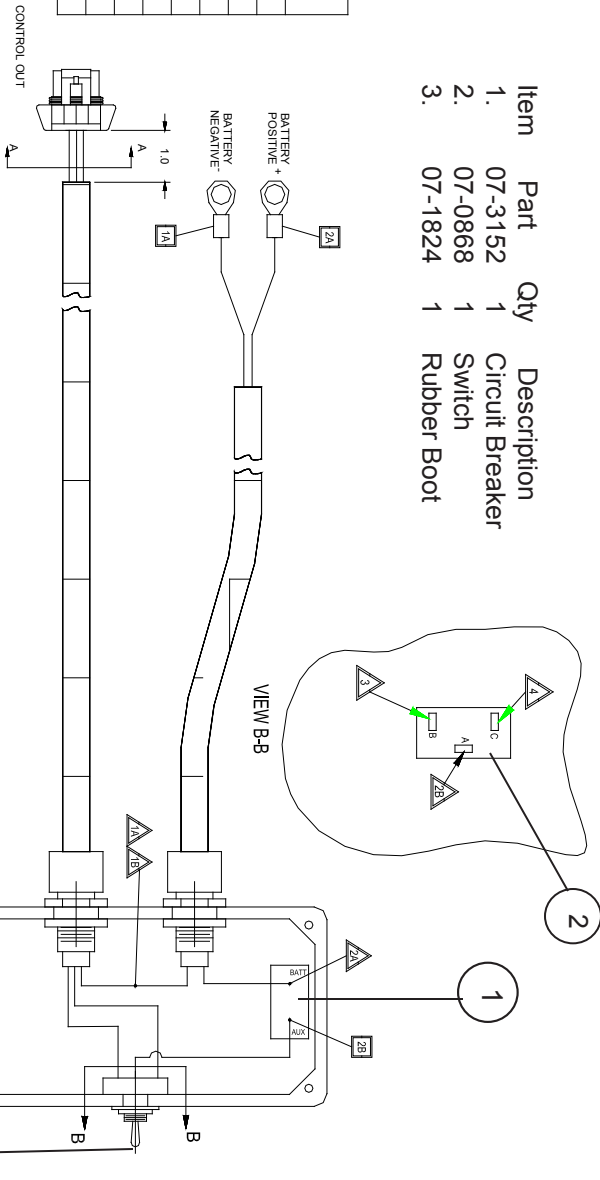

PLUG - A, D, E, G & H

VIEW "A-A"

WIRE NO.	GAUGE	IDENTIFICATION		APPLICATION	
		FROM	TO	FROM	TO
1A	16	BLACK	PACKARD PIN F	ULTRA SONIC SPLICE	
1B	16	BLACK	ULTRA SONIC SPLICE	PACKARD 1 PIN B	
1C	16	BLACK	ULTRA SONIC SPLICE	PACKARD 2 PIN B	
2	16	RED	PACKARD PIN B	PACKARD 1 PIN A	
3	16	YELLOW	PACKARD PIN C	PACKARD 2 PIN A	



A, D, E, G, H PLUG

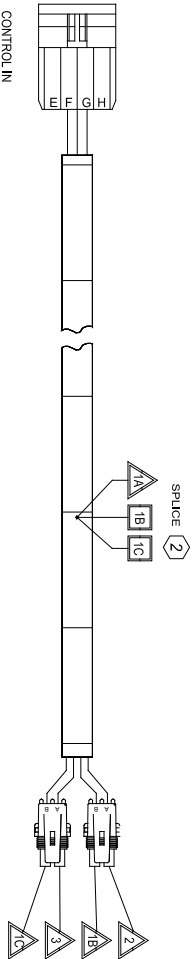

CONTROL IN

Wiring Harness

WIRE NO.		IDENTIFICATION		APPLICATION		□ END (LEFT) (BEYOND HARNESS)				△ END (LEFT) (BEYOND HARNESS)				WIRE NO.	
GUA#	ID	FROM	TO	SIZE	TYPE	EXTRA WIDE PROTECTION		SIZE	TYPE	EXTRA WIDE PROTECTION		SIZE	TYPE	WIRE NO.	
						YES	NO			YES	NO				
1A	RED	BATTERY (+)	ULTRA SONIC SPLICE	0.38	RING TERMINAL (WAYTEK # 32205)	-	X	-	ULTRA SONIC SPLICE	-	X	-	ULTRA SONIC SPLICE	1A	
1B	RED	ULTRA SONIC SPLICE	PACKCARD PIN A	-	ULTRA SONIC SPLICE	-	X	-	PACKARD 12129493 & SEAL	-	X	-	PACKARD 12129493 & SEAL	1B	
2	BLACK	BATTERY (+)	PACKCARD PIN B	0.38	RING TERMINAL (WAYTEK # 32205)	-	X	-	PACKARD 12129493 & SEAL	-	X	-	PACKARD 12129493 & SEAL	2	

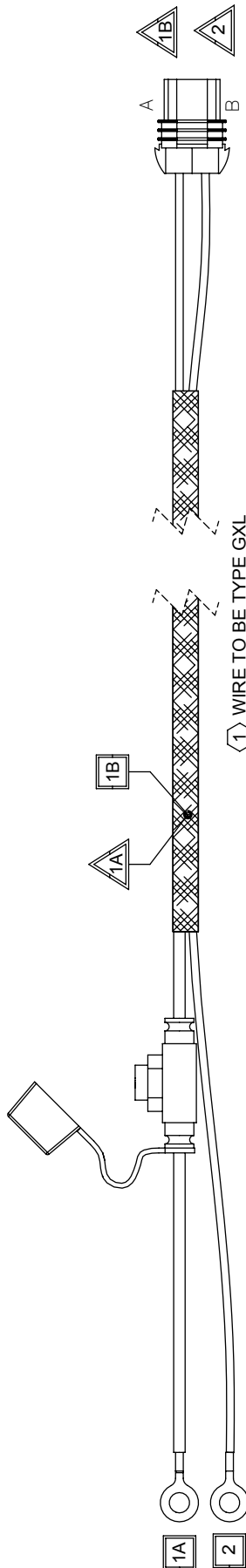

SERVICE SECTION
TROUBLESHOOTING

Wiring Harness

WIRE NO.	WIRE APPLICATION				□ END (LEFT) (BEYOND HARNESS)		△ END (RIGHT) (BEYOND HARNESS)	
	GLAZE	IDENTIFICATION	FROM	TO	TERMINAL TYPE	EXTRA WIDE PROTECTION	TERMINAL TYPE	EXTRA WIDE PROTECTION
1	18 BLACK	PACKARD PIN F (6 PIN)	PACKARD PIN A (2 PIN)	PACKARD 12048199 & SEAL	-	X	PACKARD 12048074 & SEAL	-
2	18 RED	PACKARD PIN B (2 PIN)	SWITCH 1-A	PACKARD 12048199 & SEAL	-	X	SPADE TERMINAL (FEMALE)	X
3	18 RED	PACKARD PIN C (6 PIN)	SWITCH 1-B	PACKARD 12048074 & SEAL	-	X	SPADE TERMINAL (FEMALE)	X
4	18 YELLOW	PACKARD PIN C (6 PIN)	SWITCH 1-C	PACKARD 12048074 & SEAL	-	X	SPADE TERMINAL (FEMALE)	X

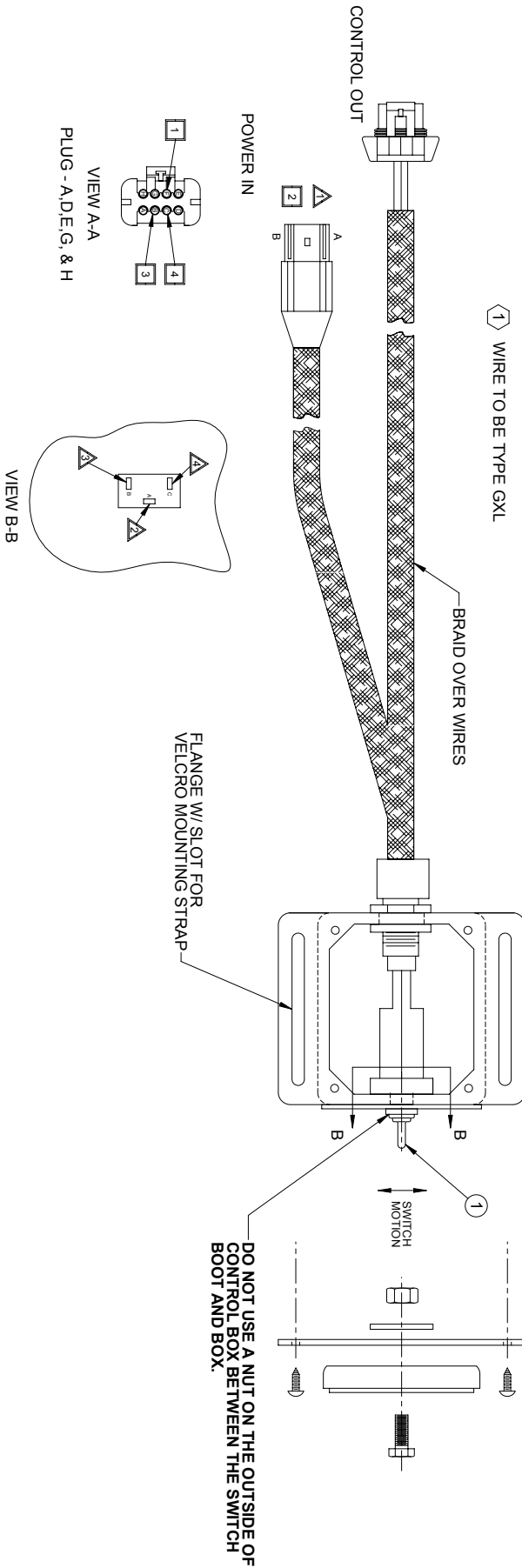
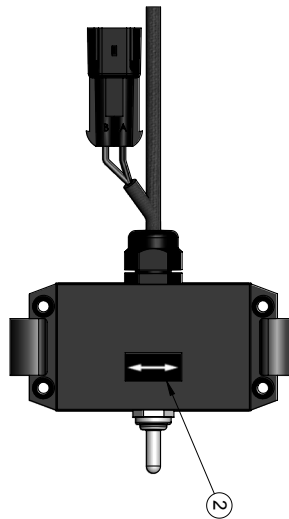

Wiring Harness

WIRE NO.	WIRE			□ END (LEFT) (BEYOND HARNESS)			△ END (RIGHT) (BEYOND HARNESS)				
	IDENTIFICATION	APPLICATION		TERMINAL		EXTRA WIDE PROTECTION		TERMINAL		EXTRA WIDE PROTECTION	
		FROM	TO	SIZE	TYPE	YES	NO	SIZE	TYPE	YES	NO
1A	BLACK	PACKARD PIN F	ULTRA SONIC SPLICE	-	PACKARD 12045773 & SEAL	-	X	-	ULTRA SONIC SPLICE	-	X
1B	BLACK	ULTRA SONIC SPLICE	DEUTSCH 1 PIN B	-	ULTRA SONIC SPLICE	-	X	-	DEUTSCH 0462-201-16141 & SEAL	-	X
1C	BLACK	ULTRA SONIC SPLICE	DEUTSCH 2 PIN B	-	ULTRA SONIC SPLICE	-	X	-	DEUTSCH 0462-201-16141 & SEAL	-	X
2	RED	PACKARD PIN B	DEUTSCH 1 PIN A	-	PACKARD 12045773 & SEAL	-	X	-	DEUTSCH 0462-201-16141 & SEAL	-	X
3	YELLOW	PACKARD PIN C	DEUTSCH 2 PIN A	-	PACKARD 12045773 & SEAL	-	X	-	DEUTSCH 0462-201-16141 & SEAL	-	X

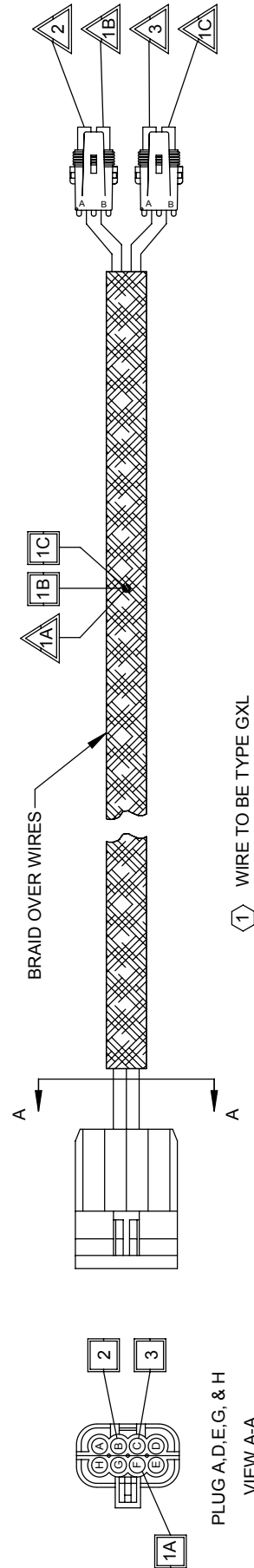

PLUG A, D, E, G, & H
VIEW A-A

Notes

Parts Manual

Table of Contents

Parts Lists	35-45
Brush Head Frames.....	36
Core Assemblies.....	37
Motor Assembly	38
Hydraulic Assembly	39
Manual Assembly.....	40
Swing Mountings	41-44
Brush Head Labels	45
Brush Head Stand	46

Brush Head Frame

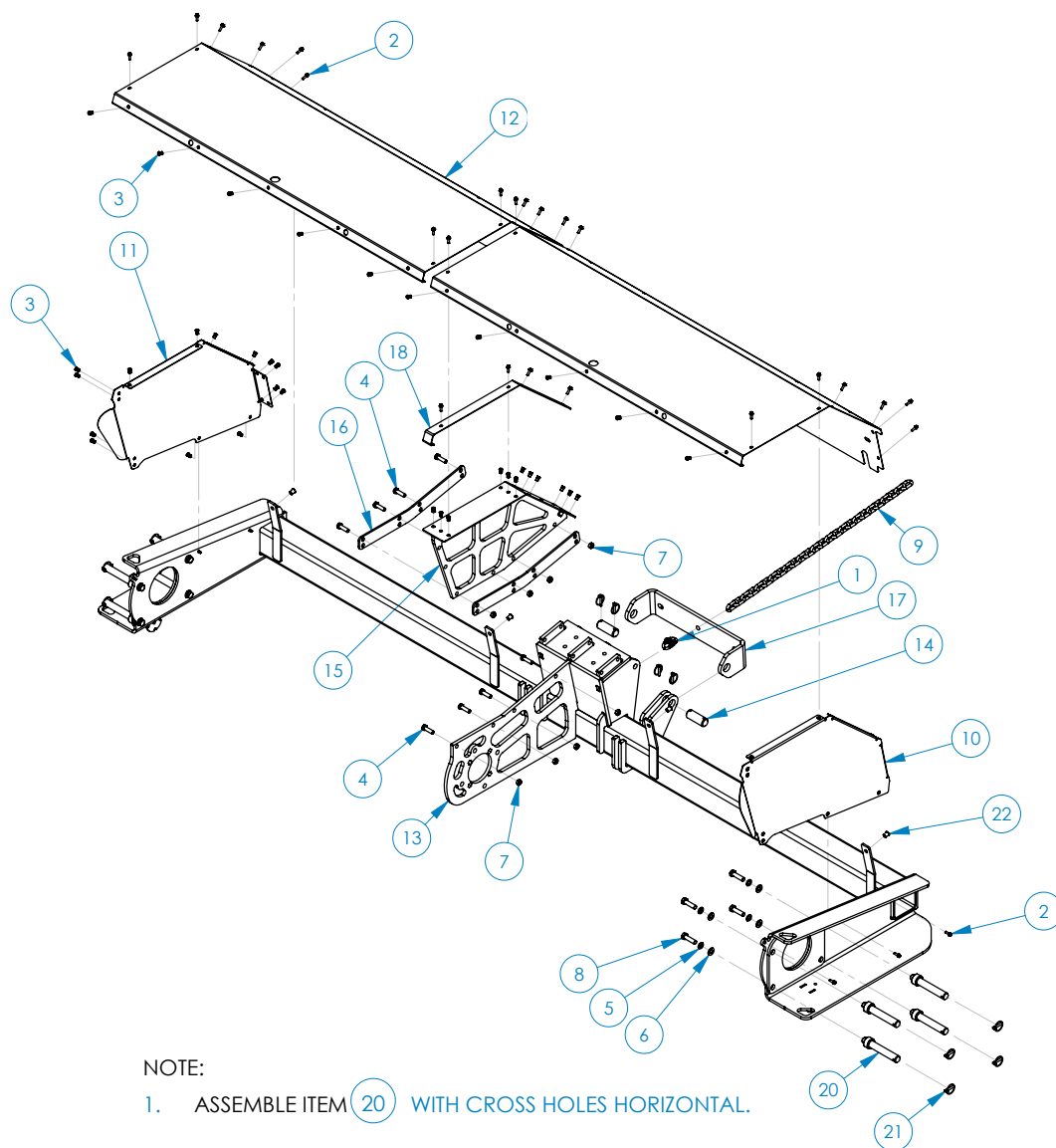

NOTE:

1. ASSEMBLE ITEM (20) WITH CROSS HOLES HORIZONTAL.

Item	Part	Qty	Description	Item	Part	Qty	Description
1.	07-2032	1	Clevis, Double Link, Gr80, 9/32	12.	13-14817	2	Sheet, Hood, 5 Ft
2.	07-2952	30	Screw, HFH, CL10.9, M6-1 x 20	13.	13-14079	2	Sheet, Hood, 6 Ft
3.	07-3617	50	Nut, Insert, Hex, M6 x 1	14.	13-14550-10	1	Weld, Brush Frame, 10 Ft
4.	07-3760	8	Screw, HHC, CL10.9, M12-1.75 x 40mm	15.	13-14550-12	1	Weld, Brush Frame, 12 Ft
5.	07-4227	8	Washer, Lock, Split, M14	16.	13-14787	2	Pin, 1 1/4 x 3.25, with Holes
6.	07-4228	8	Washer, Flat, CL8.8, M14	17.	13-14812	1	Weld, Plate, Middle
7.	07-4610	8	Nut, Hex, Lock, CL10.9, M12-1.75	18.	13-14814	2	Plate, Mounting, Middle
8.	07-6026	8	Screw, HHC, CL10.9, M14-2 x 50 mm	19.	13-14815	1	Plate, Mounting, Brush Head, Pivot
9.	13-11195	1	Chain, 3/8, 26 Links	20.	13-14816	1	Sheet, Hood Filler
10.	13-14077	1	Sheet, Hood, Side, Left	21.	13-16403	8	Pin, with Shoulder
11.	13-14078	1	Sheet, Hood, Side, Right	22.	RHW8068	12	Pin, Lynch, 1/4
					RHW8642	4	Nut, Rivet, 5/16-18, .150-.312 Grip

Core Assemblies

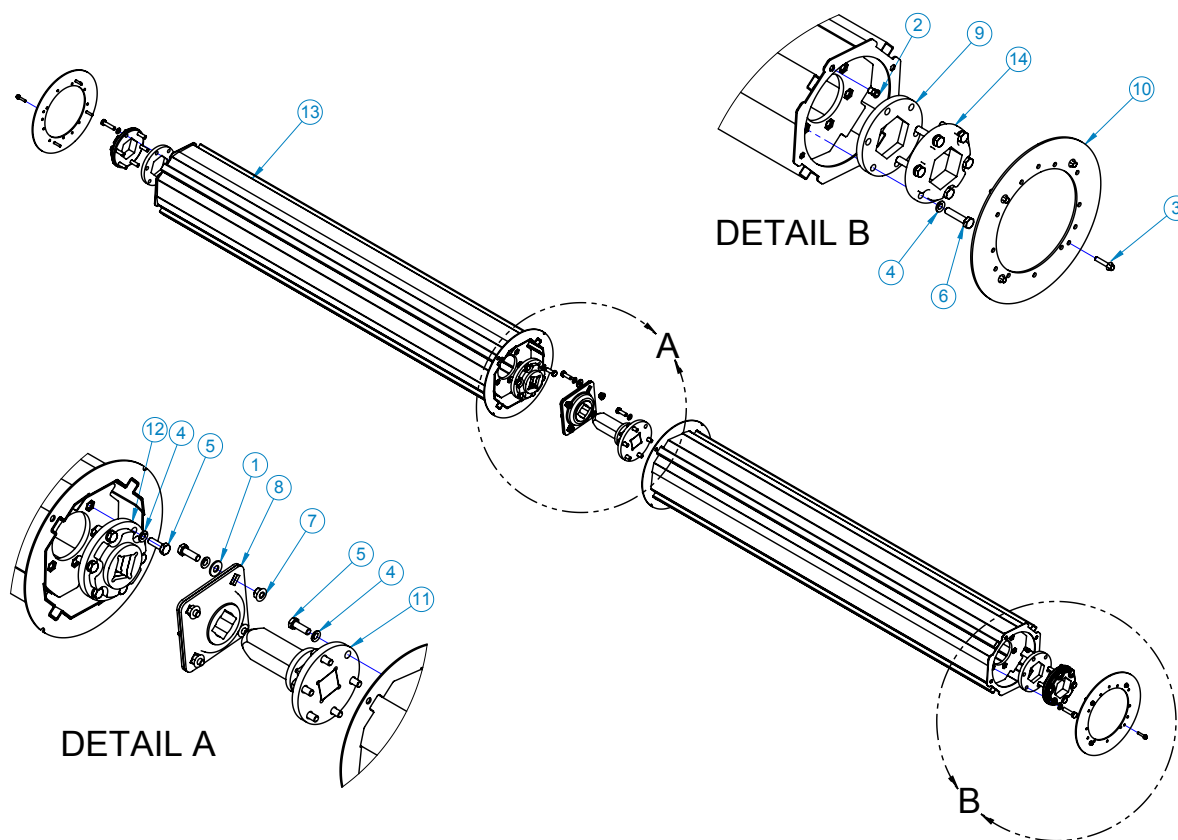

- 01-1211-10 Set, Section, 36, Mixed, 10 ft
- 01-1211-12 Set, Section, 36, Mixed, 12 ft
- 01-1212-10 Set, Section, 36, Poly, 10 ft
- 01-1212-12 Set, Section, 36, Poly, 12 ft

Item	Part	Qty	Description
1.	07-3279	4	Washer, Flat, Gr8, 3/8
2.	07-3617	8	Nut, Insert, Hex, M6 x 1
3.	07-3731	8	Screw, HHC, CL10.9, M6-1 x 30mm
4.	07-3747	28	Washer, Lock, Split, Medium, M10
5.	07-3749	16	Screw, HHC, CL10.9, M10-1.5 x 30mm
6.	07-3752	12	Screw, HHC, CL10.9, M10-1.5 x 45mm
7.	07-6056	4	Nut, Flange, M10-1.5
8.	07-6866	1	Bearing, 1 1/2 Square, 4 Bolt
9.	13-12738	2	Plate, Hex, Hub, 5.25
10.	13-13166	2	Plate, Ring, Core, End
11.	13-14805	1	Weld, Square Shaft, 1 1/2, Core
12.	13-14808	1	Weld, Hub, Square, 1 1/2, with Doublers
13.	13-15866-5	2	Weld, Core, 10, 5 Ft
	13-15866-6	2	Weld, Core, 10, 6 Ft
14.	13-16225	2	Plate, Reciever, Hex, 2.5

Motor Assembly

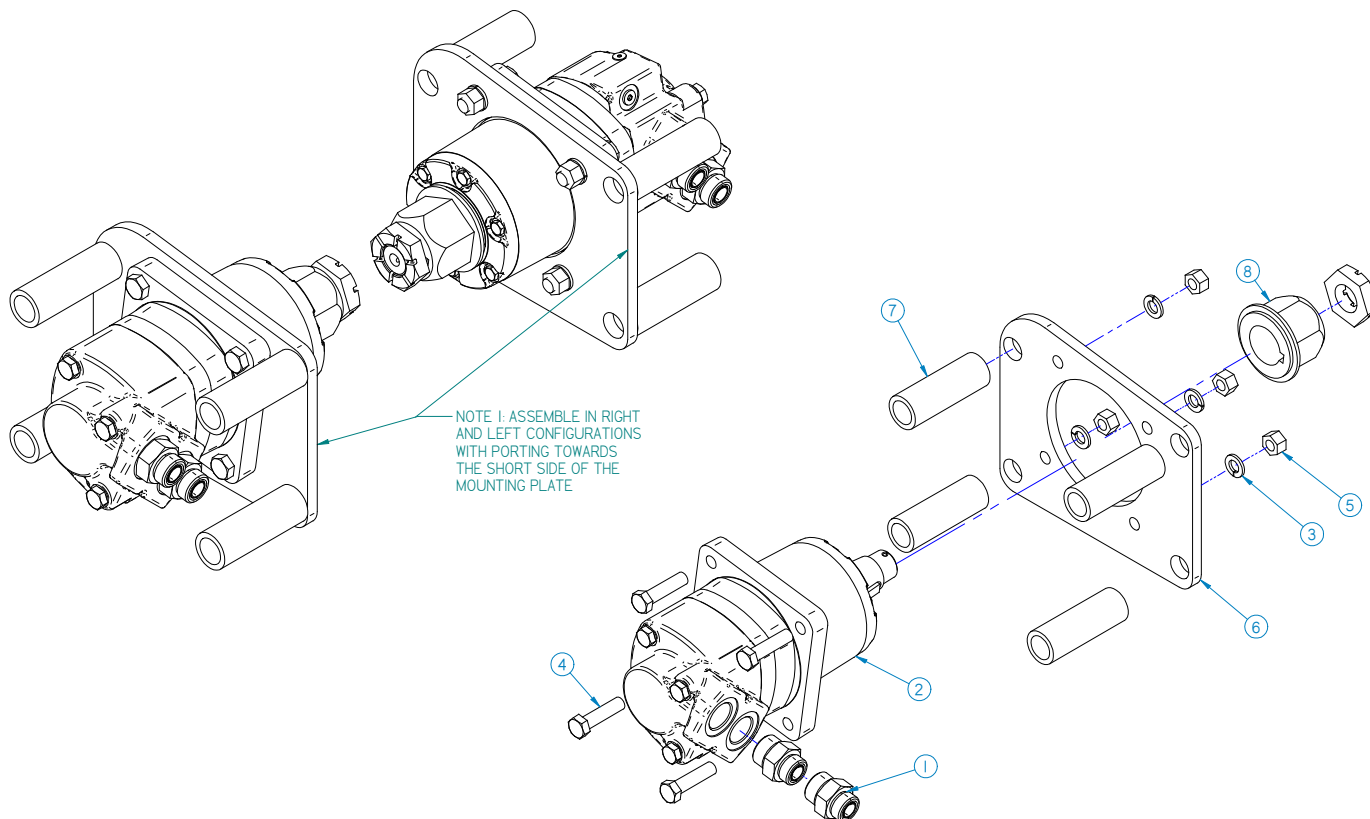

Hydraulic Motor Requirements

Model 21319 and 21343 Require 2 03-4430

Model 21321 and 21344 Require 1 03-4430 (Right) and 1 03-5192 (Left)

Model 21321 and 21345 Require 2 03-5192

Item	Part	Qty	Description
1.	03-2035	2	Fitting, 12MF-16MB
2.	See Above Chart		
3.	07-4227	4	Washer, Lock, Split, M14
4.	07-7008	4	Screw, HHC, CL10.9, M14-2.0 x 55mm
5.	07-7009	4	Nut, Hex, CL8.8, M14-2.0
6.	13-15145	1	Plate, Mounting, Motor, Eaton
7.	13-15149	4	Tube, Round, 1 1/2 x 1.06 x 4.25
8.	13-15208	1	Hub, Hex, Drive

Replacement Parts for 03-4430 :

03-5043 Front, Seal Kit

03-5659 Rear, Seal Kit

03-5660 Complete, Seal Kit

Replacement Parts for 03-5192 :

03-5663 Front, Seal Kit

03-5664 Rear, Seal Kit

Must Order Both for Complete

Hydraulic Assembly

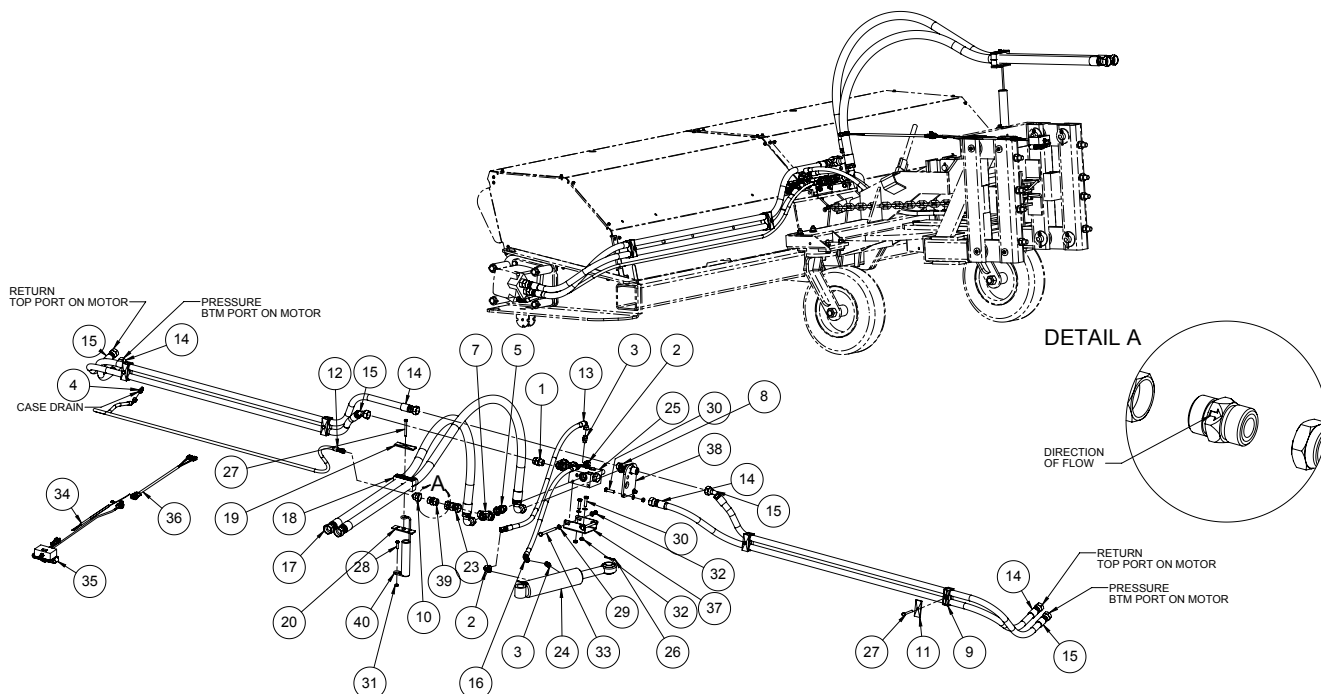

Replacement Parts for 03-5724:

45617 Seal Kit
104605 Cylinder Rod

Replacement Parts for 03-4887:

03-4888 Seal Kit
03-5035 Cylinder Rod

Item	Part	Qty	Description	Item	Part	Qty	Description
1.	03-1945	1	Fitting, Adapter, HP, 1 1/16MOR, 3/4MFS	07-7150	1	Valve, Cartridge, Press. Comp.	
2.	03-2092	2	Fitting, Elbow, HP, 90°, 9/16MOR, 3/8MFS	07-7151	1	Valve, Cartridge, Relief	
3.	03-2291	2	Fitting, Adapter, HP, 3/8MFS, 9/16MOR	07-7152	1	Valve, Cartridge, Directional	
4.	03-3344	1	Fitting, Adapter, HP, 7/16MOR, 1/4MFS	07-7153	2	Coil, 12 Volt (1018999 & Down)	
5.	03-3779	1	Fitting, Adapter, HP, 1 1/16MOR, 1/4FFS	07-7769	2	Coil, 12 Volt (1019200 & Up)	
7.	03-4183	1	Fitting, Cross, 3/4MFS, All Ends			Replacement Nut - 07-7771	
8.	03-5160	1	Tee, 12MF-12MF-12MF	07-7134	2	Coil, 24 Volt (1018999 & Down)	
9.	03-5207	4	Hose, Cradle	07-7770	2	Coil, 24 Volt (1019200 & Up)	
10.	03-5212	1	Fitting, Reducer, 12FFS, 4MFS			Replacement Nut - 07-7771	
11.	03-5218	4	Cover, Plate	26.	07-0206	2	Pin, Cotter, Gr2, 3/16 x 2
12.	03-5235	1	Hose, 1/4 x 84, TC, 4FFS, 4FFS45, 10ft	27.	07-3651	5	Screw, HHC, Gr8, 5/16-18 x 3
	03-5246	1	Hose, 1/4 x 96, TC, 4FFS, 4FFS45, 12ft	28.	07-3740	1	Screw, HHC, CL10.9, M8-1.25 x 30mm
13.	03-5236	1	Hose, 3/8 x 42, TC, 6FFS, 6FFS90	29.	07-3745	8	Washer, Flat, CL8.8, M10
14.	03-5237	2	Hose, 3/4 x 90, TC, 12FFS, 12FFS, 10ft	30.	07-3751	4	Screw, HHC, CL10.9, M10-1.5 x 40mm
	03-4119	2	Hose, 3/4 x 102 TC, 12FFS, 12FFS, 12ft	31.	07-4604	1	Nut, Hex, Lock, M8-1.25, CL10.9
15.	03-5238	2	Hose, 3/4 x 82, TC, 12FFS, 12FFS45, 10ft	32.	07-4622	6	Nut, Hex, Lock, ST, CL10.9, M10-1.5
	03-5248	2	Hose, 3/4 x 94, TC, 12FFS, 12FFS45, 12ft	33.	07-7028	2	Screw, HHC, CL10.9, M10-1.5 x 130mm
16.	03-5239	1	Hose, 3/8 x 32, TC, 6FFS, 6FFS45	34.	LAF9441	1	Wire Assembly, 9 Ft (1018999 & Down)
17.	03-5241	2	Hose, 1 x 120, TC, 16FFS, 12FFS90	07-7737	1	Wire Harness, 9 Ft (1019200 & Up)	
18.	03-5242	1	Hose, Cradle	35.	LAF9444	1	Wire, Harness, with Box (1018999 & Down)
19.	03-5243	1	Cover, Plate			Wire Harness, with Box (1019200 & Up)	
20.	03-5244	1	Weld, Plate	36.	07-7733	1	Wire, Harness, Power Lead, 126 inches
23.	03-5494	1	Fitting, 12FF, 12FF	37.	105840	1	Washer, Fender
24.	03-4887	1	Cylinder, 2.5 x 7.5 (09/23/09 & Before)	38.	13-15085	1	Plate, Mounting
	03-5724	1	Cylinder, 2.5 x 1.38 x 7.5, 3.5K (9/24/09 & After)	39.	13-15519	1	Plate, Mounting, Bulkhead
25.	03-5215	1	Manifold, Swing, 12 Volt (1018999 & Down)	40.	LAF4707	1	Valve, Check, In-Line, 12MF, 12MF
	03-5835	1	Manifold, Swing, 12 Volt (1019200 & Up)	41.	RHW8618	1	Hose Spring
	03-5280	1	Manifold, Swing, 24 Volt (1018999 & Down)				
	03-5836	1	Manifold, Swing, 24 Volt (1019200 & Up)				

Manual Assembly

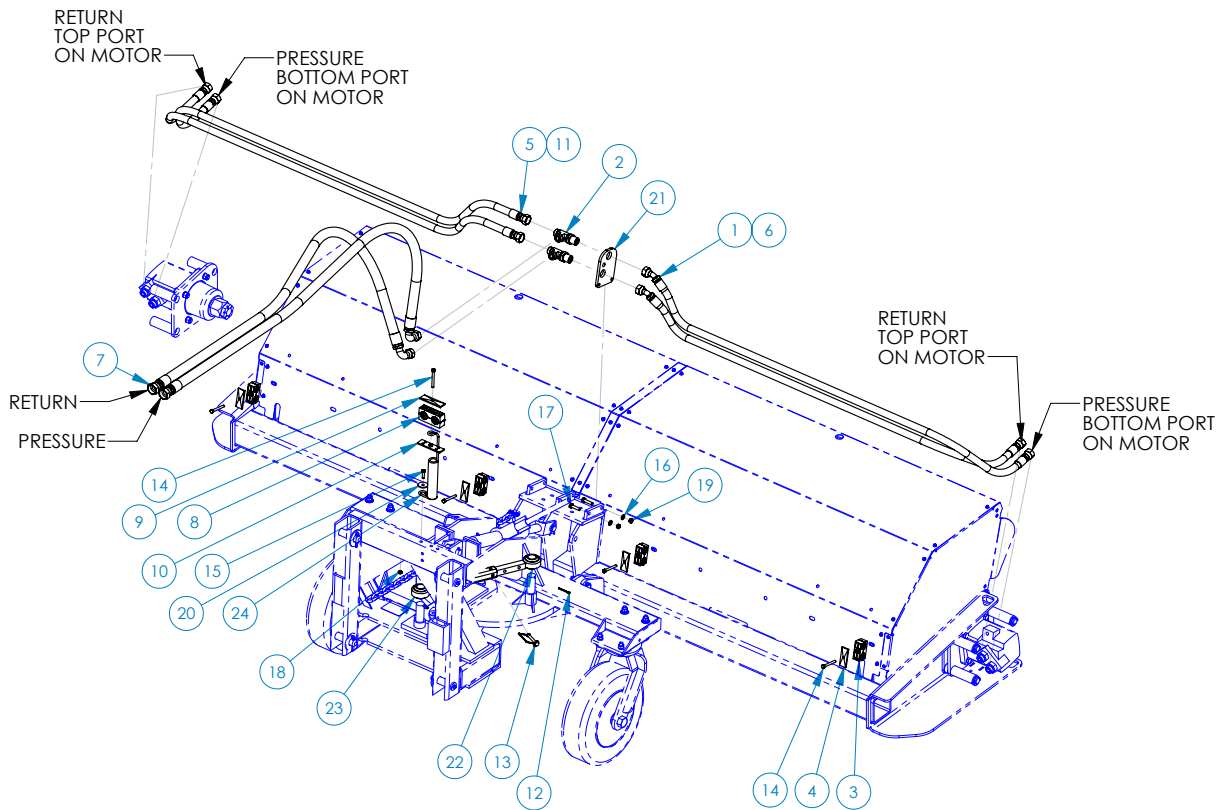

Item	Part	Qty	Description
1.	03-5238	2	Hose, .75 x 82, 12FF-12FF45, 3K, TC (10 Ft)
	03-4119	2	Hose, .75 x 102, 12FF-12FF, 3K, TC (12 Ft)
2.	03-5160	2	Tee, 12MF-12MF-12MF, Bulkhead, R
3.	03-5207	4	Hose, Cradle, for 1.12 OD
4.	03-5218	4	Cover, Plate, for 1.12 OD
5.	03-5237	2	Hose, .75 x 90, 12FF-12FF, 3K, TC (10 Ft)
	03-5248	2	Hose, .75 x 94, 12FF-12FF45, 3K, TC (12 Ft)
7.	03-5241	2	Hose, 1 x 120, 12FF90-16FF, 3K, TC
8.	03-5242	1	Hose, Cradle, for 1.40 OD
9.	03-5243	1	Cover, Plate, for 1.40 OD
10.	03-5244	1	Weld, Plate, for 1.40 OD
12.	07-0206	2	Pin, Cotter, Gr2, 3/16 x 2
13.	07-2105	1	Pin, Lock, 3/8 Square Bail
14.	07-3651	5	Screw, HHC, Gr5, 5/16-18 x 3
15.	07-3740	1	Screw, HHC, CL10.9, M8-1.25 x 30mm
16.	07-3745	2	Washer, Flat, CL8.8, M10
17.	07-3751	2	Screw, HHC, CL10.9, M10-1.5 x 40mm
18.	07-4604	1	Nut, Hex, Lock, CL10.9, M8-1.25
19.	07-4622	2	Nut, Hex, Lock, CL10.9, M10-1.5
20.	105840	2	Washer, Fender
21.	13-15519	1	Plate, Mounting, Bulkhead
22.	13-2452	1	Weld, Link, Inner
23.	13-2453	1	Weld, Link, Outer
24.	RHW8618	1	Hose, Spring

Bolt-On Swing Mounting

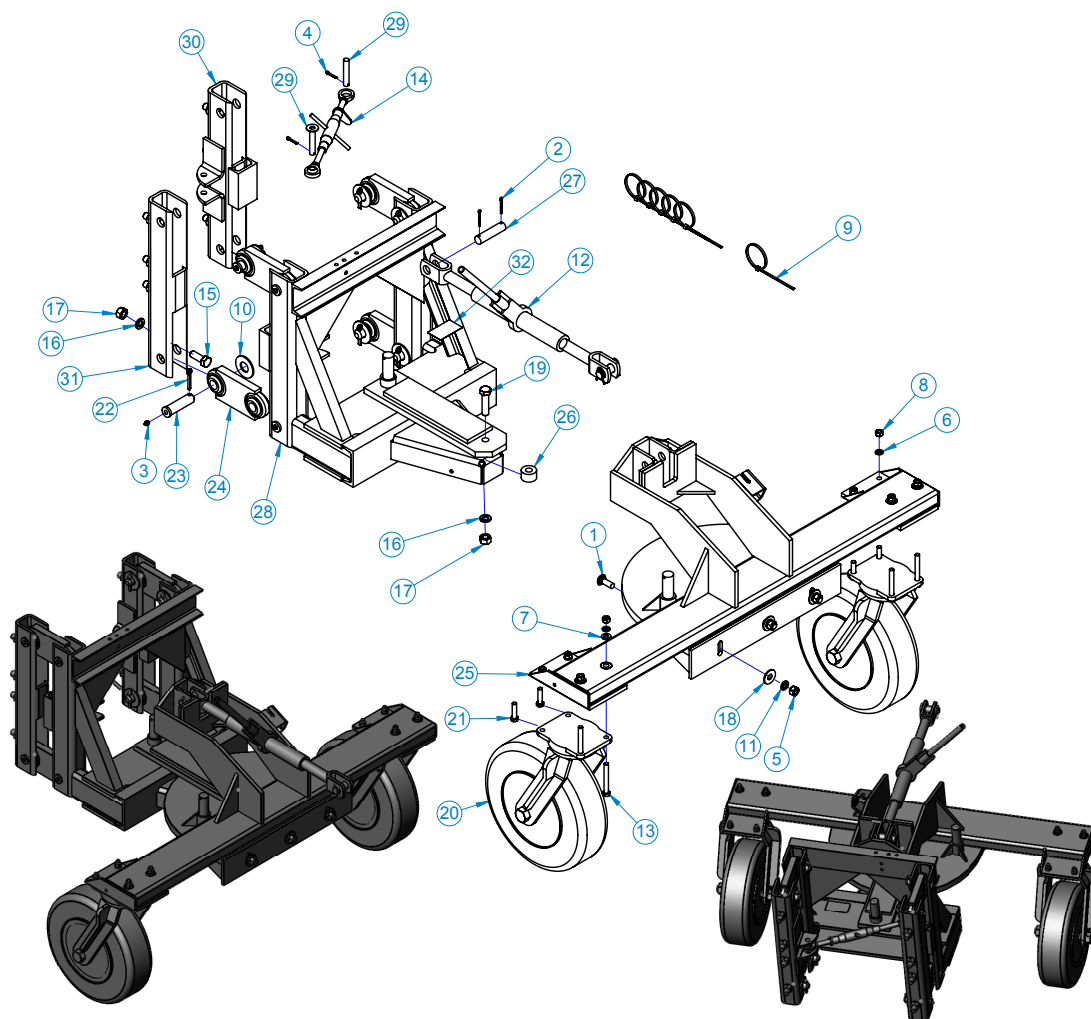

Item	Part	Qty	Description	Item	Part	Qty	Description
1.	07-0119	3	Bolt, Carriage, Gr5, 5/8-11 x 1 3/4	17.	07-3066	9	Nut, Hex, Gr8, 3/4-10
2.	07-0206	2	Pin, Cotter, Gr2, 3/16 x 2	18.	07-3120	3	Washer, Flat, Gr8, 5/8
3.	07-0223	8	Fitting, Zerk, 1/8NPT	19.	07-3544	1	Screw, HHC, Tap, Gr5, 3/4-10 x 3
4.	07-0786	2	Pin, Cotter, Gr2, 3/16 x 1 1/2	20.	07-3256	2	Assembly, Caster, 6 Ply, Taper Bearing
5.	07-1294	3	Nut, Hex, Gr8, 5/8-11		07-3941	2	Assembly, Caster, Solid Taper Bearing
6.	07-1762	8	Washer, Lock, Split, Medium, 1/2	21.	07-5075	4	Screw, HHC, Gr8, 1/2-13 x 2
7.	07-1763	4	Washer, Flat, Gr8, 1/2	22.	07-5355	8	Pin, Cotter, 5/16 x 2
8.	07-1764	8	Nut, Hex, Gr8, 1/2-13	23.	12-0292	8	Pin, Hitch, 1.122 x 4
9.	07-1817	6	Tie, Plastic, 15 inch	24.	12-4152	4	Weld, Link, Hitch, 6.25
10.	07-1841	8	Washer, Flat, Gr2, 1 1/8	25.	13-2218	1	Weld, Plate, Swing
11.	07-1872	3	Washer, Lock, Split, Medium, 5/8	26.	13-2230	1	Bushing, 1 3/4 x 25/32 x 1 1/16
12.	07-2104	1	Toplink, Ratchet, 8 Stroke	27.	13-2484	1	Pin, 1 x 4, with Holes
13.	07-2360	4	Screw, HHC, Gr8, 1/2-13 x 4	28.	13-3134	1	Weld, Frame, Swing
14.	07-2484	1	Toplink, CAT 0, 10 3/4C x 16 3/8E	29.	13-3413	2	Weld, Pin, Mounting, 5/8 x 3 1/2
15.	07-3064	8	Screw, HHC, Gr8, 3/4-10 x 2	30.	13-4386	1	Weld, Bracket, Lift
16.	07-3065	9	Washer, Lock, Split, Medium, 3/4	31.	13-4387	1	Tube, Lift
				32.	50-0635	1	Label, Part Number, Date

Weld-On Swing Mounting

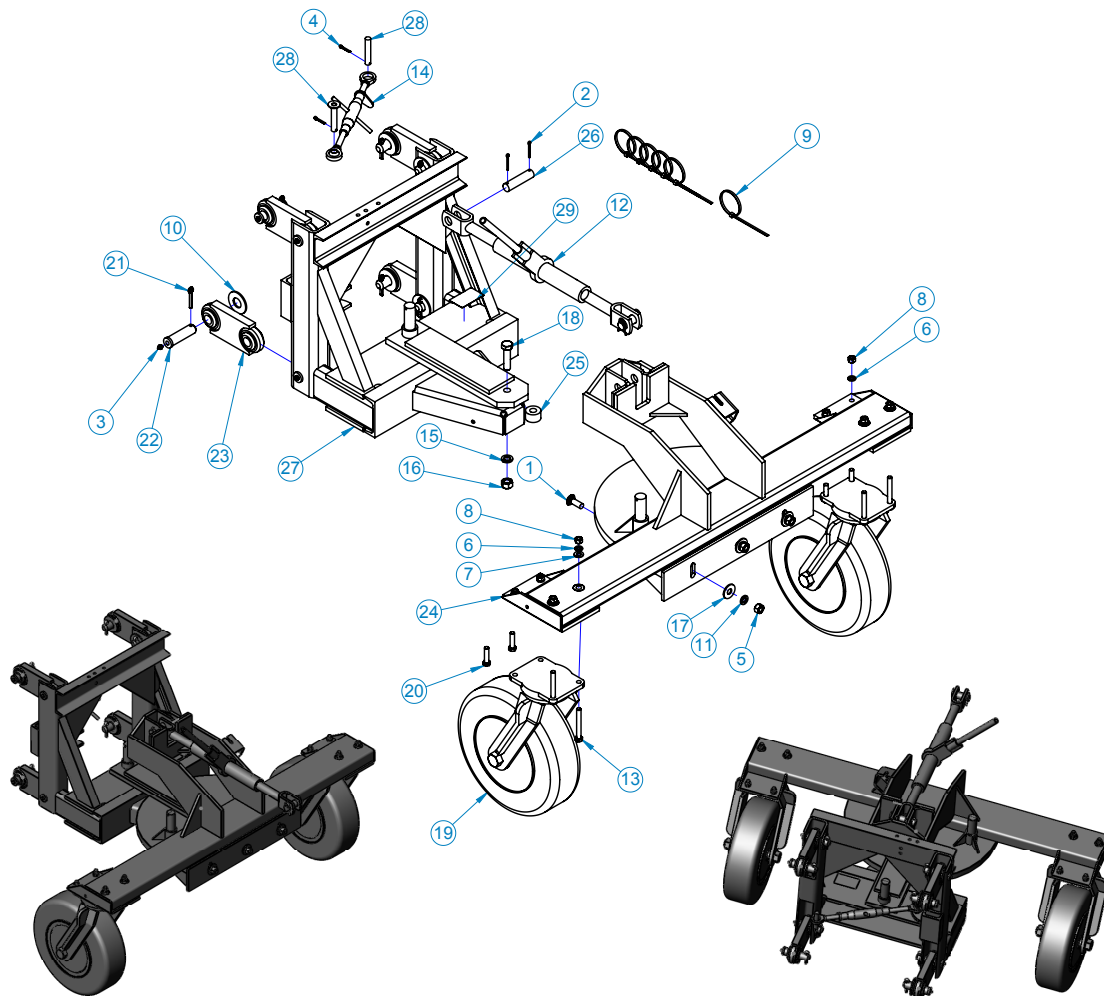

Item	Part	Qty	Description	Item	Part	Qty	Description
1.	07-0119	3	Bolt, Carriage, Gr5, 5/8-11 x 1 3/4	16.	07-3066	1	Nut, Hex, Gr8, 3/4-10
2.	07-0206	2	Pin, Cotter, Gr2, 3/16 x 2	17.	07-3120	3	Washer, Flat, Gr8, 5/8
3.	07-0223	8	Fitting, Zerk, 1/8NPT	18.	07-3544	1	Screw, HHC, Tap, Gr5, 3/4-10 x 3
4.	07-0786	2	Pin, Cotter, Gr2, 3/16 x 1 1/2	19.	07-3256	2	Assembly, Caster, 6 Ply, Taper Bearing
5.	07-1294	3	Nut, Hex, Gr8, 5/8-11		07-3941	2	Assembly, Caster, Solid, Taper Bearing
6.	07-1762	8	Washer, Lock, Split, Medium, 1/2	20.	07-5075	4	Screw, HHC, Gr8, 1/2-13 x 2
7.	07-1763	4	Washer, Flat, Gr8, 1/2	21.	07-5355	8	Pin, Cotter, 5/16 x 2
8.	07-1764	8	Nut, Hex, Gr8, 1/2-13	22.	12-0292	8	Pin, Hitch, 1.122 x 4
9.	07-1817	6	Tie, Plastic, 15 inch	23.	12-4152	4	Weld, Link, Hitch, 6.25
10.	07-1841	8	Washer, Flat, Gr2, 1 1/8	24.	13-2218	1	Weld, Plate, Swing
11.	07-1872	3	Washer, Lock, Split, Medium, 5/8	25.	13-2230	1	Bushing, 1 3/4 x 25/32 x 1 1/16
12.	07-2104	1	Toplink, Ratchet, 8 Stroke	26.	13-2484	1	Pin, 1 x 4, with Holes
13.	07-2360	4	Screw, HHC, Gr8, 1/2-13 x 4	27.	13-3134	1	Weld, Frame, Swing
14.	07-2484	1	Toplink, CAT 0, 10 3/4C x 16 3/8E	28.	13-3413	2	Weld, Pin, Mounting, 5/8 x 3 1/2
15.	07-3065	1	Washer, Lock, Split, Medium, 3/4	29.	50-0635	1	Label, Part Number, Date

Swing Mounting 3 Point Category II

Serial # 0943101 and Higher

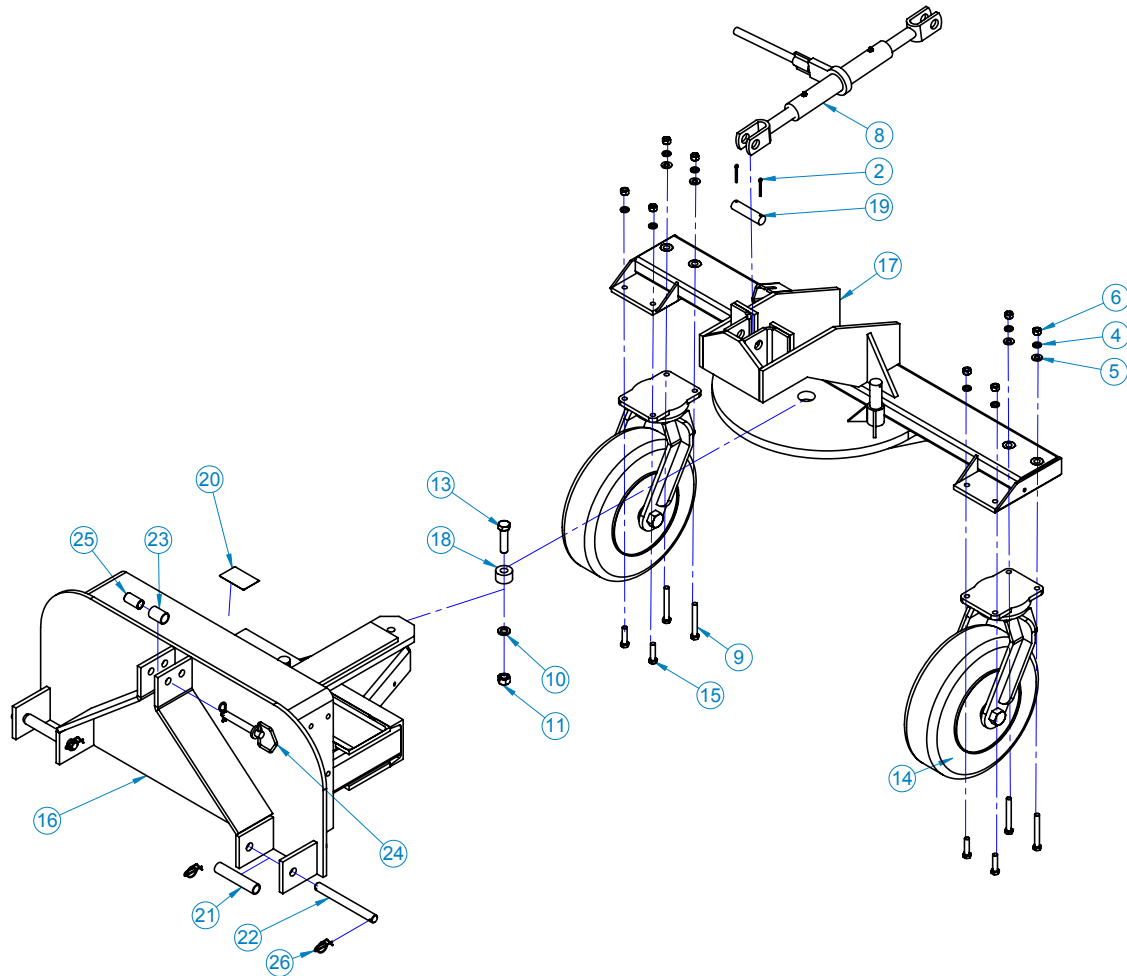

Item	Part	Qty	Description	Item	Part	Qty	Description
1.	07-0119	3	Bolt, Carriage, Gr5, 5/8-11 x 1 3/4	14.	07-3941	2	Caster, Assembly, Swivel
2.	07-0206	2	Pin, Cotter, Gr2, 3/16 x 2	15.	07-5075	4	Screw, HHC, Gr8, 1/2-13 x 2
3.	07-1294	3	Nut, Hex, Gr8, 5/8-11	16.	13-17196	1	Weld, Frame, 3 Point
4.	07-1762	8	Washer, Lock, Split, Medium, 1/2	17.	13-2218	1	Weld, Plate, Swing
5.	07-1763	4	Washer, Flat, Gr8, 1/2	18.	13-2230	1	Bushing, 1 3/4 x 25/32 x 1 1/16
6.	07-1764	8	Nut, Hex, Gr8, 1/2-13	19.	13-2484	1	Pin, 1 x 4, with Holes
7.	07-1872	3	Washer, Lock, Split, Medium, 5/8	20.	50-0635	1	Label, Part Number, Date
8.	07-2104	1	Toplink, Ratchet, 1 inch Pins	21.	LAF9429	2	Tube, Round, 1.13 x .885 x 5.56
9.	07-2360	4	Screw, HHC, Gr8, 1/2-13 x 4	22.	LAF9430	2	Rod, 1 x 3.62, with Chamfers
10.	07-3065	1	Washer, Lock, Split, Medium, 3/4	23.	LAF9433	1	Bushing, Toplink, Category 2-3
11.	07-3066	1	Nut, Hex, Gr8, 3/4-10	24.	P121200	1	Pin, Hitch
12.	07-3120	3	Washer, Flat, Gr8, 5/8	25.	P126250	1	Bushing, Category I-II
13.	07-3544	1	Screw, HHC, Gr8, 3/4-10 x 3	26.	RHW8130	4	Rue Ring, Cotter, .88, Heavy

Brush Head Labels

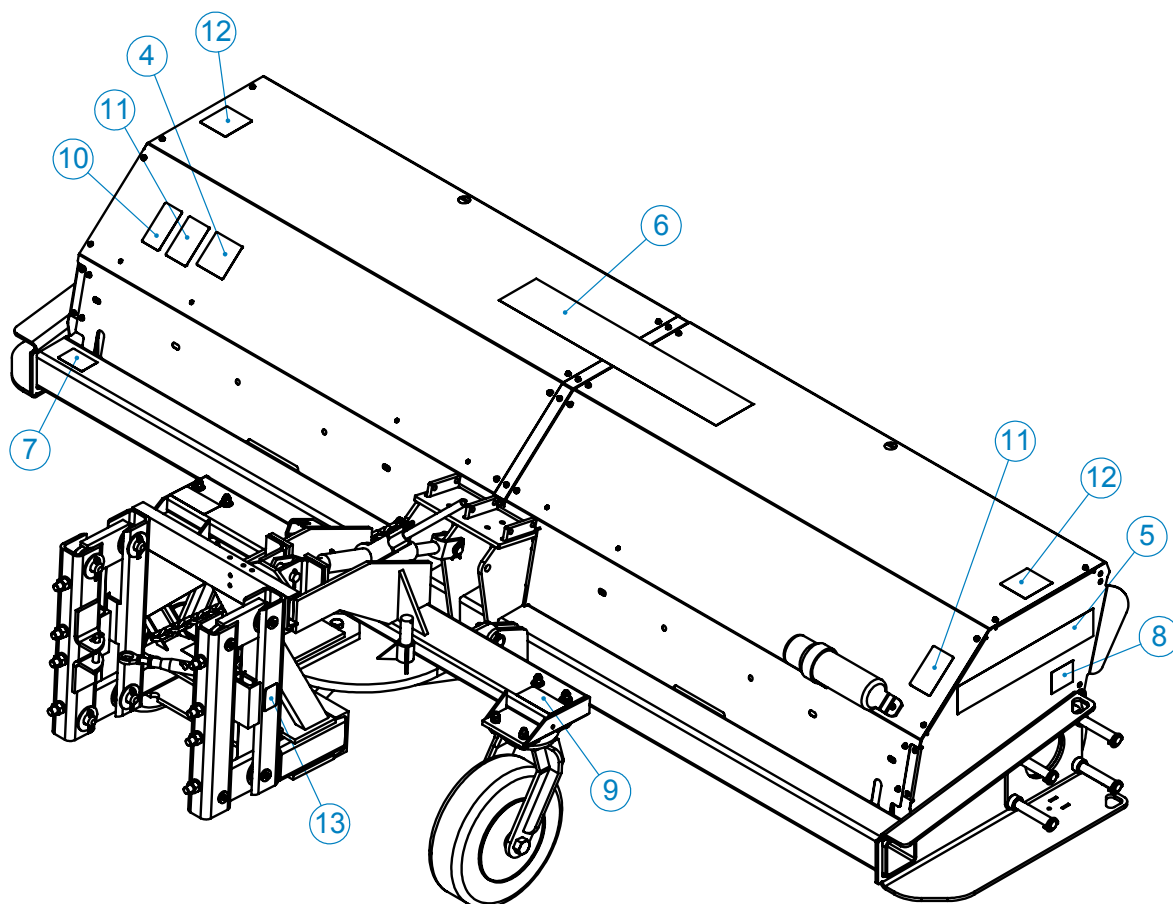

Item	Part	Qty	Description
4.	41043	1	Decal, Warning, Hazardous Dust
5.	50-0185	2	Label, Logo, Medium, White
6.	50-0252	1	Label, Logo, Large, White
7.	50-0634	1	Label, Serial Number, Sweepster
8.	50-0643	2	Label, Tie Down Point
9.	50-0721	2	Label, Warning, Crush Hazard
10.	50-0722	1	Label, Warning, Misuse Hazard
11.	50-0724	1	Label, Warning, High Pressure Fluid Hazard
12.	50-0726	2	Label, Warning, Flying Objects & Entanglement
13.	50-0775	2	Label, Warning, Crush Hazard

Brush Head Stand

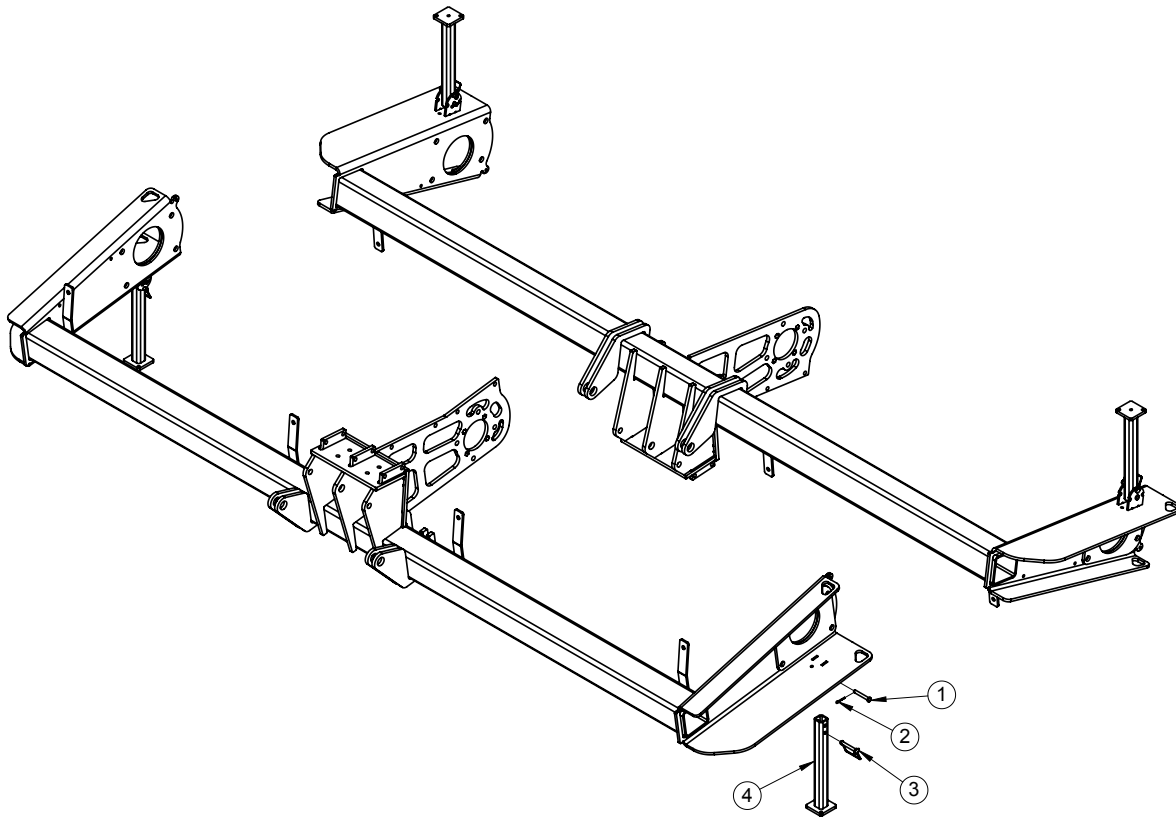

Item	Part	Qty	Description
1.	07-0260	2	Pin, Clevis, Gr2, 3/8 x 2 3/4
2.	07-0699	2	Pin, Cotter, Gr2, 1/8 x 1 1/4
3.	07-4748	2	Pin, Lock, 3/8 x 2
4.	13-13898	2	Weld, Stand

Options Section

Table of Contents

Options	47-55
Hood Kits.....	48-49
Dust Suppression.....	50
Water Tank	51-52
Sight Indicator Kits	53
Case Drain Kit.....	54
Hydraulic Angle	55

OPTION SECTION
HOOD KITS

180° Hood with Drape

28-9927-10 10 Ft

28-9927-12 12 Ft

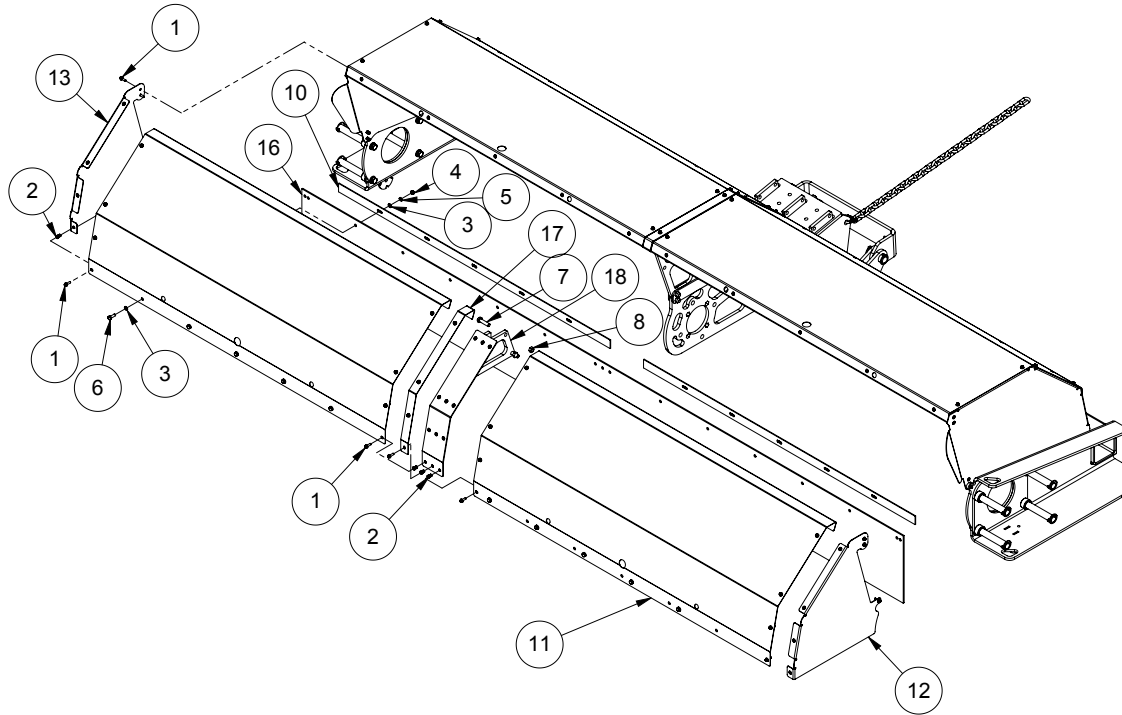

Item	Part	Qty	Description
1.	07-2952	36	Screw, HFH, CL10.9, M6-1 x 20
2.	07-3617	20	Nut, Insert, Hex, M6 x 1
3.	07-3736	20	Washer, Flat, CL8.8, M8
4.	07-3737	10	Nut, Hex, CL10, M8-1.25
5.	07-3738	10	Washer, Lock, Split, Medium, M8
6.	07-3739	10	Screw, HHC, CL10.9, M8-1.25 x 25mm
7.	07-3761	2	Screw, HHC, CL10.9, M12-1.75 x 45mm
8.	07-4610	2	Nut, Hex, Lock, CL10.9, M12-1.75
10.	13-12834	2	Plate, Retainer, 5 ft, Dirt Deflector (10 Ft)
	13-12298	2	Plate, Retainer, 6 ft, Dirt Deflector (12 Ft)
11.	13-14575	2	Sheet, Hood, 5 ft 180° (10 Ft)
	13-14536	2	Sheet, Hood, 6 ft 180° (12 Ft)
12.	13-14545	1	Sheet, Side, Left, Hood
13.	13-14546	1	Sheet, Side, Right, Hood
16.	13-14577	1	Flap, Hood, 180° (10 Ft)
	13-14578	1	Flap, Hood, 180° (12 Ft)
17.	13-15325	1	Sheet, 180° Hood Filler
18.	13-15326	1	Weld, Support

180° Hood

28-9932-10 10 Ft
28-9932-12 12 Ft

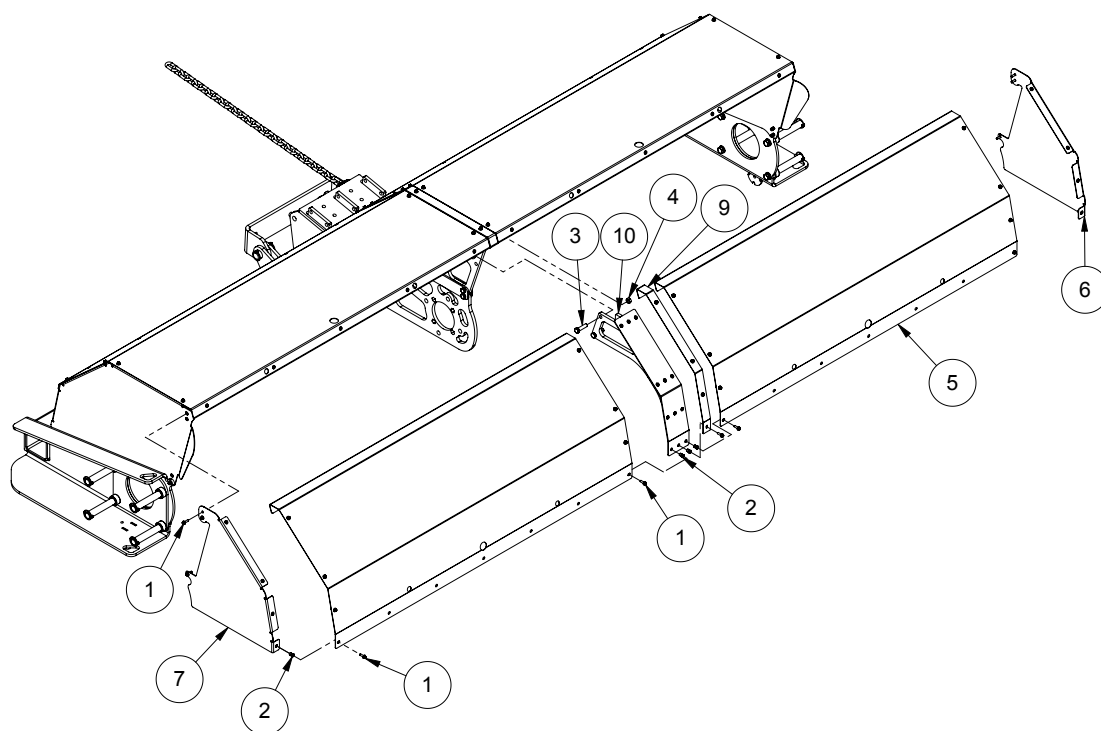

Item	Part	Qty	Description
1.	07-2952	36	Screw, HFH, CL10.9, M6-1 x 20
2.	07-3617	20	Nut, Insert, Hex, M6 x 1
3.	07-3761	2	Screw, HHC, CL10.9, M12-1.75 x 45mm
4.	07-4610	2	Nut, Hex, Lock, CL10.9, M12-1.75
5.	13-14575	2	Sheet, Hood, 5 ft, 180° (10 Ft)
	13-14536	2	Sheet, Hood, 6 ft, 180° (12 Ft)
6.	13-14545	1	Sheet, Side, Left
7.	13-14546	1	Sheet Side, Right
9.	13-15325	1	Sheet, 180° Hood Filler
10.	13-15326	1	Weld, Support, Hood

Dust Suppression

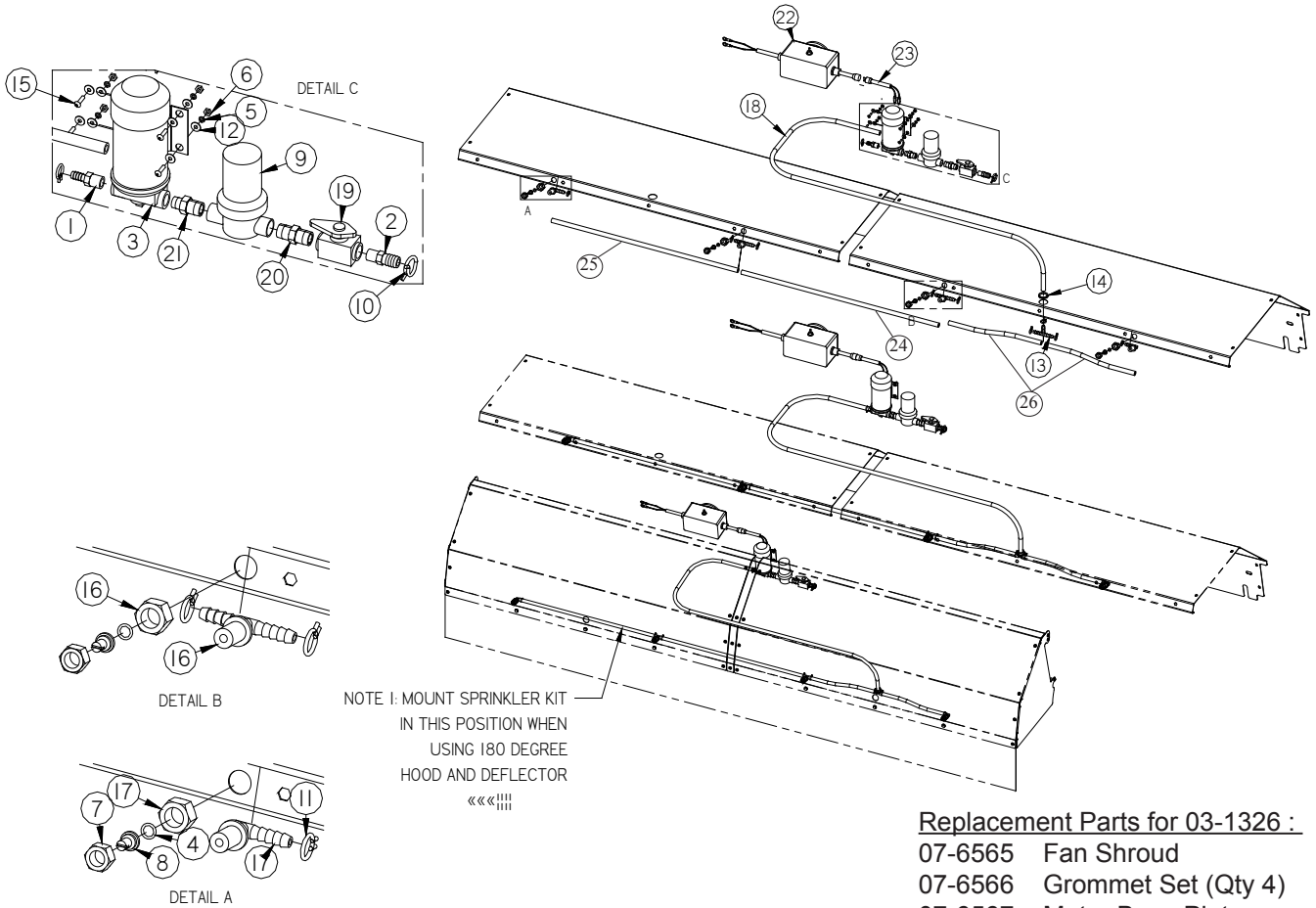
Kit: 28-9928

Replacement Parts for 03-1326 :

07-6565 Fan Shroud
 07-6566 Grommet Set (Qty 4)
 07-6567 Motor Base Plate

Replacement Parts for LAF8316 :

07-7492 Switch
 07-3152 Circuit Breaker
 07-1824 Rubber Boot

Item	Part	Qty	Description
1.	03-0457	1	Barb, 6, 6MP
2.	03-1226	1	Barb, 10, 8MP
3.	03-1326	1	Pump, Flojet, Water, 2.1gpm, 12 volt
	03-2558	1	Pump, Flojet, Water, 2.1gpm, 24 volt
4.	03-3537	4	O-Ring, #8, Face Seal
5.	07-0140	4	Washer, Lock, Gr2, #10
6.	07-0141	4	Nut, Hex, Gr2, 10-24
7.	07-0413	4	Nozzle, Cap, Nylon
8.	07-0414	4	Nozzle, Tip, Brass
9.	07-0532	1	Strainer, Hypro, Water
10.	07-0547	1	Clamp, Spring, 7/8, Hose
11.	07-0549	10	Clamp, Spring, 5/8, Hose
12.	07-1430	8	Washer, Flat, #10
13.	07-3869	1	Fitting, Barb, Tee, Nylon, 3/8
14.	07-4804	1	Grommet, Rubber, 1-1/4 x 7/8 x 1/16
15.	07-4831	4	Screw, BHC, 10-24UNC, 2B x 3/4

Item	Part	Qty	Description
16.	07-4861	2	Nozzle, Tee, without Clamp
17.	07-4862	2	Nozzle, Elbow, without Clamp
18.	07-5127	25ft	Hose, Clear, Vinyl, 3/8 (To make # 24, 25, 26)
19.	07-6862	1	Valve, Shut-off, 1/2
20.	07-6863	1	Fitting, Nipple, 1/2
21.	07-6864	1	Fitting, Nipple, 1/2 x 3/8
22.	LAF8316	1	Wire Harness, with Box
23.	LAF8320	1	Wire Harness, 11 Ft
24.	07-5127	33 in.	Hose, Clear, Vinyl, 3/8, 10 Ft
	07-5127	39 in.	Hose, Clear, Vinyl, 3/8, 12 Ft
25.	07-5127	31 in.	Hose, Clear, Vinyl, 3/8, 10 Ft
	07-5127	37 in.	Hose, Clear, Vinyl, 3/8, 12 Ft
26.	07-5127	32 in.	Hose, Clear, Vinyl, 3/8, 10 Ft
	07-5127	38 in.	Hose, Clear, Vinyl, 3/8, 12 Ft

85 Gallon Water Tank

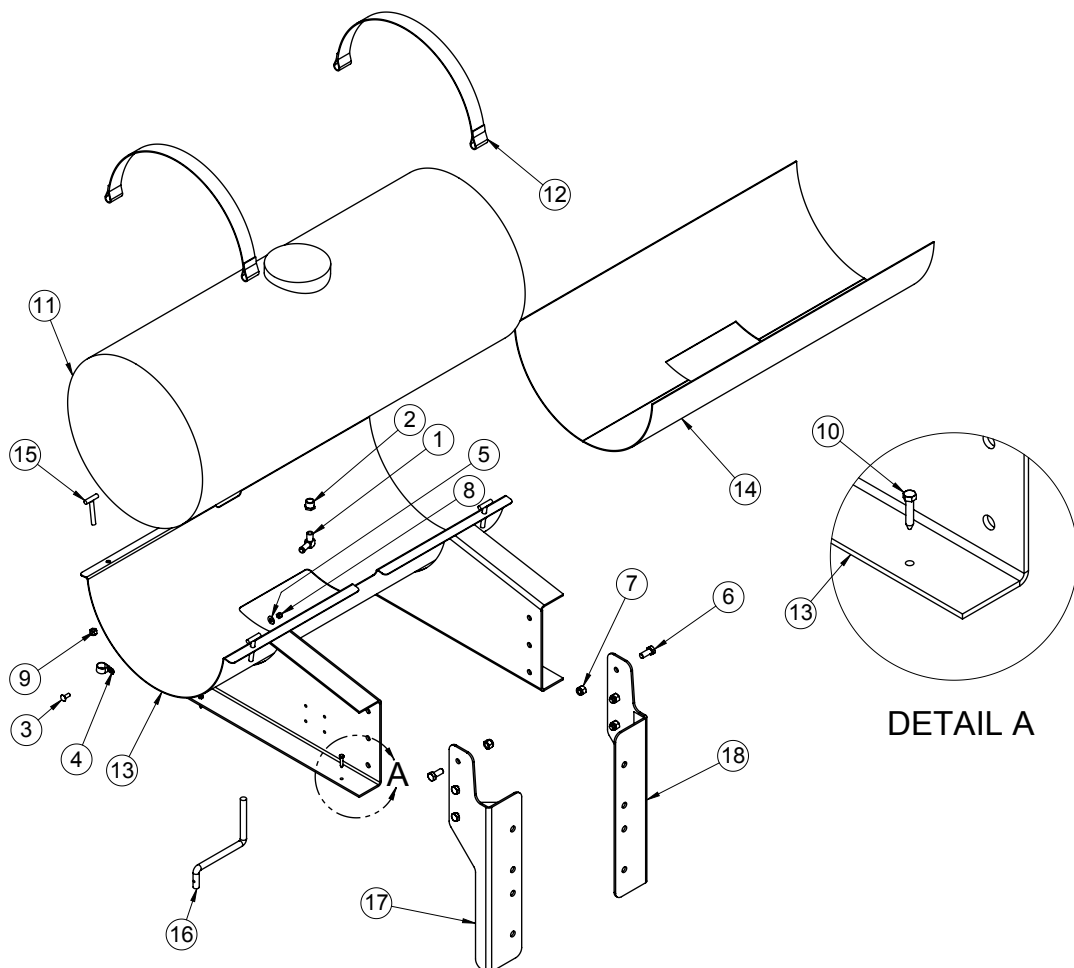
Kit: 28-4318

Item	Part	Qty	Description	Item	Part	Qty	Description
1.	03-0714	1	Barb, 10, 8MP90	13.	13-10074	1	Weld, Mounting, Water Tank
2.	03-1068-9	1	Fitting, 8FP-12MP	14.	13-10075	2	Rubber, Neoprene, Tank, Pad
3.	07-1716	1	Bolt, Carriage, Gr5, 3/8-16 x 1	15.	13-10081	4	Weld, Bolt, Tee, 3 1/2
4.	07-1734	1	Clamp, Rubber Coat, 1 inch	16.	13-10485	1	Handle, Ratchet
5.	03-3279	1	Washer, Flat, Gr8, 3/8	17.	13-15523	1	Weld, Mounting, Tank, Left
6.	03-3433	6	Screw, HHC, Gr8, 5/8-11 x 1 1/2	18.	13-15524	1	Weld, Mounting, Tank, Right
7.	07-4031	6	Nut, Hex, Nylock, Gr8, 5/8-11				
8.	07-4036	1	Nut, Hex, Nylock, Gr8, 3/8-16				
9.	07-4037	4	Nut, Hex, Nylock, Gr8, 1/2-13				
10.	07-4262	4	Bolt, Lag, 5/16 x 1 1/2				
11.	07-4682	1	Tank, Water, Poly, 85 gallons				
12.	09-0202	2	Strap, Nylon, 37 inches				

Replacement Parts for 07-4682 :

07-6088	Cap
07-7168	Drain Assembly

85 Gallon Water Tank 3 Point

Kit: 28-10217

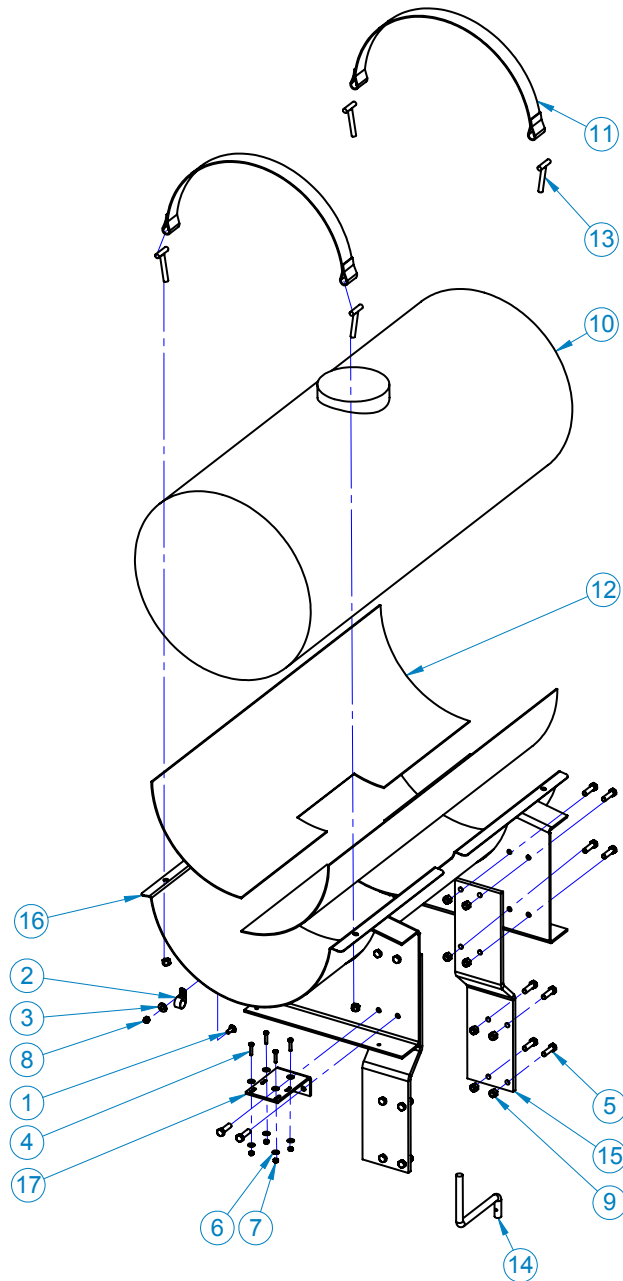

Replacement Parts for 07-4682 :

 07-6088 Cap
 07-7168 Drain Assembly

Item	Part	Qty	Description	Item	Part	Qty	Description
1.	07-1716	1	Bolt, Carriage, Gr5, 3/8-16 x 1	9.	07-4037	20	Nut, Hex, Nylock, Gr8, 1/2-13
2.	07-1734	1	Clamp, Rubber, Vinyl, Coat, Hose, 1	10.	07-4682	1	Tank, Water, Poly, 85 Gallon, 32 Inch
3.	07-3279	1	Washer, Flat, Gr8, 3/8	11.	09-0202	2	Strap, Water, Tank, 34 Inch
4.	07-3638	4	Screw, HHC, Gr8, 1/4-20 x 1 1/4	12.	13-10075	2	Rubber, Neoprene, Tank Pad
5.	07-3671	16	Screw, HHC, Gr8, 1/2-13 x 1 3/4	13.	13-10081	4	Weld, Bolt, Tee, 3 1/2
6.	07-4032	8	Washer, Flat, Gr8, 1/4	14.	13-10485	1	Handle, Ratchet
7.	07-4033	4	Nut, Hex, Nylock, Gr8, 1/4-20	15.	13-16545	2	Plate, Tank, Mounting, Water, 3 Point
8.	07-4036	1	Nut, Hex, Nylock, Gr8, 3/8-16	16.	13-16548	1	Weld, Mounting, Tank, Water
				17.	13-16549	1	Plate, Mounting, Water Pump

Sight Indicators

Kit: 28-9965

Item	Part	Qty	Description
1.	07-3279	2	Washer, Flat, Gr8, 3/8
2.	07-5839	2	Nut, Hex, Nylock, 3/8-24
3.	07-6597	4	Screw, HFH, CL10.9, M6-1 x 30
4.	13-14857	2	Weld, Sight Indicator
5.	13-9567	2	Ball, 2 1/8, Red, with Hole

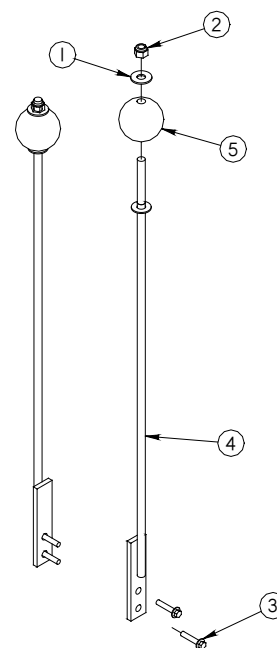

Kit: 11-5897

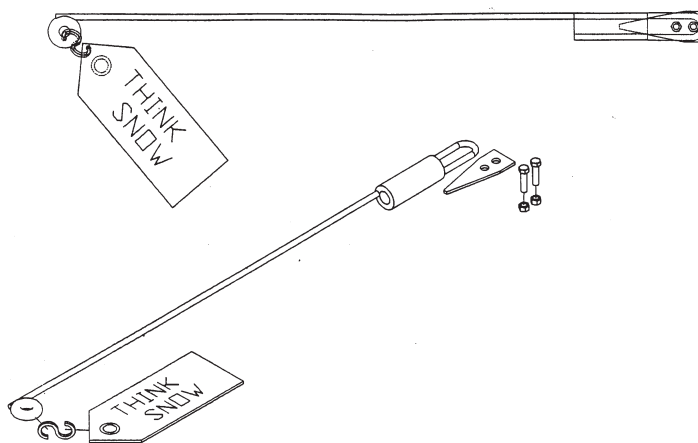

Case Drain Assembly

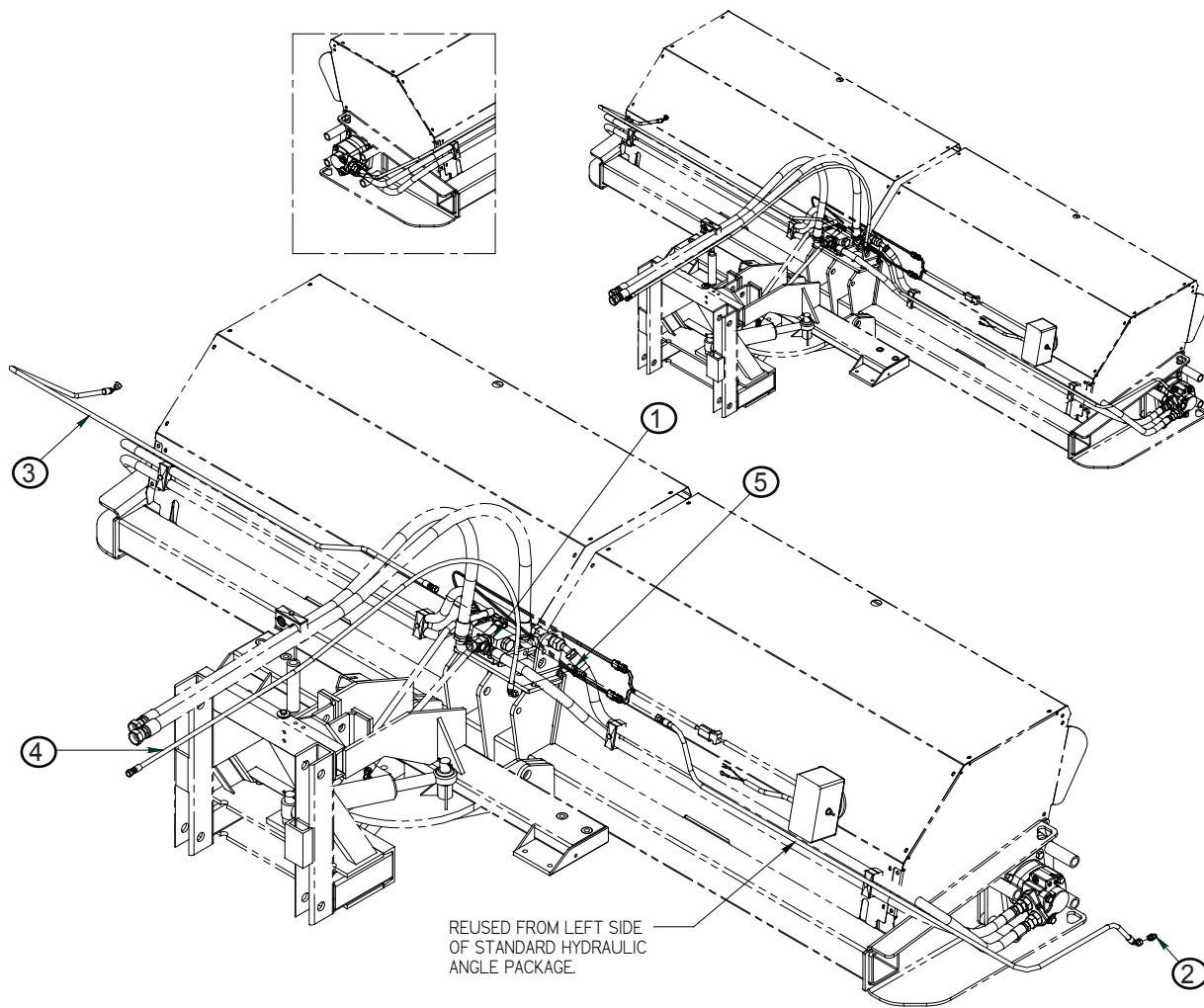

Item	Part	Qty	Description
1.	03-3135	1	Tee, 12MB-12MF-12MF
2.	03-3344	1	Fitting, 4MB-4MF
3.	03-5245	1	Hose, .25 x 104, 4FF-4FF45, 3K, AR
4.	03-5247	1	Hose, .25 x 120, 4FF-4FF90, 3K, AR
5.	03-5249	1	Tee, 4MF-4MF-4MF, BHD, R

HYDRAULIC ANGLE ASSEMBLY

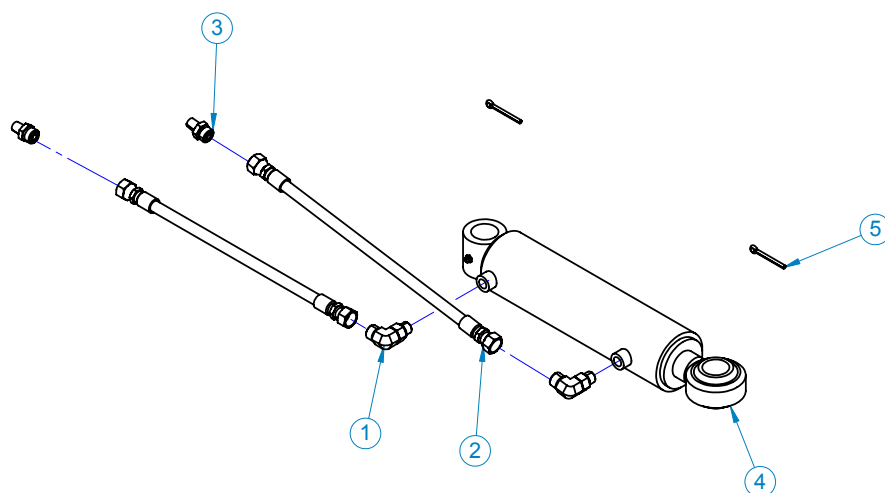

Item	Part	Qty	Description
------	------	-----	-------------

1.	03-2092	2	Elbow, 90°, 6MB-6MF
2.	03-2155	2	Hose, .25 x 72, 6FF-6FF, 3.25K
3.	03-2159	2	Fitting, 6MF-4MP
4.	03-5724	1	Cylinder, 2.5 x 1.25, 3.5K (09/24/09 and Up)
	03-4887	1	Cylinder, 2.5 x 1.38 x 7.5, 3.5K (09/23/09 and Down)
6.	07-0206	2	Pin, Cotter, Gr2, 3/16 x 2

Replacement Parts for 03-5724 :
45617 Seal Kit

Replacement Parts for 03-4887 :
03-4888 Seal Kit
03-5035 Rod

HYDRAULIC ANGLE CYLINDER

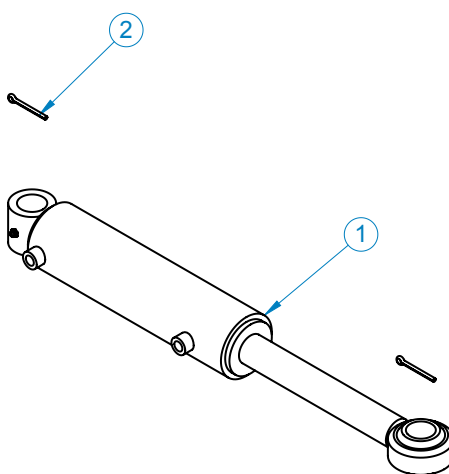

Item	Part	Qty	Description
------	------	-----	-------------

1.	03-5724	1	Cylinder, 2.5 x 1.25, 3.5K (09/24/09 and Up)
	03-4887	1	Cylinder, 2.5 x 1.38 x 7.5, 3.5K (09/23/09 and Down)
2.	07-0206	2	Pin, Cotter, Gr2, 3/16 x 2

Notes

Appendix

Table of Contents

Bolt Torque Specifications.....	58
Hydraulic Fittings Torque Specifications	59-60
Warranty Information.....	61

APPENDIX
TORQUE SPECS.**Bolt Torque Specifications**

Body Size Grade 5	Ft-lbs		Body Size Class 8.8	Ft-lbs
1/4 - 20	6 ± 1		M6 - 1.0	5 ± 1
- 28	7 ± 1		n/a	-
5/16 - 18	13 ± 3		n/a	-
- 24	14 ± 3		n/a	-
3/8 - 16	23 ± 5		M8 - 1.25	14 ± 3
- 24	26 ± 5		- 1.0	-
7/16 - 14	37 ± 8		M10 - 1.5	29 ± 6
- 20	41 ± 9		- 0.75	-
1/2 - 13	56 ± 11		M12 - 1.75	50 ± 10
- 20	63 ± 12		- 1.0	-
9/16 - 12	82 ± 14		M14 - 2.0	80 ± 14
- 18	91 ± 16		- 1.5	-
5/8 - 11	113 ± 20		M16 - 2.0	125 ± 22
- 18	127 ± 23		- 1.5	-
3/4 - 10	201 ± 26		n/a	-
- 16	223 ± 29		n/a	-
7/8 - 9	321 ± 41		M20 - 2.5	244 ± 31
- 14	355 ± 46		- 1.5	-
1 - 8	483 ± 62		M24 - 3.0	422 ± 54
- 12	528 ± 68		- 2.0	-

Body Size Grade 8	Ft-lbs		Body Size Class 10.9	Ft-lbs
1/4 - 20	9 ± 2		M6 - 1.0	8 ± 1
- 28	10 ± 2		n/a	-
5/16 - 18	18 ± 4		n/a	-
- 24	20 ± 4		n/a	-
3/8 - 16	32 ± 7		M8 - 1.25	20 ± 4
- 24	37 ± 8		- 1.0	-
7/16 - 14	52 ± 11		M10 - 1.5	40 ± 8
- 20	58 ± 12		- 0.75	-
1/2 - 13	80 ± 16		M12 - 1.75	69 ± 14
- 20	90 ± 18		- 1.0	-
9/16 - 12	115 ± 20		M14 - 2.0	110 ± 20
- 18	128 ± 23		- 1.5	-
5/8 - 11	159 ± 28		M16 - 2.0	173 ± 31
- 18	180 ± 32		- 1.5	-
3/4 - 10	282 ± 36		n/a	-
- 16	315 ± 41		n/a	-
7/8 - 9	454 ± 59		M20 - 2.5	337 ± 44
- 14	500 ± 65		- 1.5	-
1 - 8	681 ± 88		M24 - 3.0	583 ± 75
- 12	746 ± 97		- 2.0	-

Foot-pounds may be converted to Newton Meters by multiplying by 1.35582

Foot-pounds may be converted to Inch-pounds by multiplying by 12.

If the nut and screw are not the same grade, the lower grade will always be used.

NOTE - Nylock nuts are utilized when greater resistance to vibrating loose is required, and greater operating temperatures are not a factor. In addition, like lock nuts, nylock nuts have a safety feature that if the bolt does vibrate loose, the nut will remain on the screw. Install nylock nuts to the standard torque shown above.

Hydraulic Torque Specifications

Face Seal: Assembly, Tube to Fitting

Note - Face seal fittings have the most reliable sealing method and therefore, should be used whenever possible.

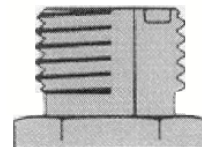

Installation

1. Make sure threads and sealing surfaces are free of burrs, nicks, scratches, or any foreign materials.
2. Install proper SAE o-ring to end of fitting if not already installed. Ensure o-ring is fully seated and retained properly.
3. Lubricate o-ring with a light coating of clean hydraulic oil.
4. Position tube and nut squarely on face seal of fitting and tighten nut finger tight.
5. Using appropriate torquing device, tighten to given torque rating from the table below.

Torque Values:

SAE Dash Size	Tube Side Thread Size	In-lbs	Ft-lbs
-4	9/16 - 18	220 ± 10	18 ± 1
-6	11/16 - 16	320 ± 25	27 ± 2
-8	13/16 - 16	480 ± 25	40 ± 2
-10	1 - 14	750 ± 35	63 ± 3
-12	1 3/16 - 12	1080 ± 45	90 ± 4
-16	1 7/16 - 12	1440 ± 90	120 ± 8
-20	1 11/16 - 12	1680 ± 90	140 ± 8
-24	2 - 12	1980 ± 100	165 ± 8

NOTE - ft-lb may be converted to Newton Meters by multiplying by 1.35582.
NOTE - in-lbs may be converted to Newton Meters by multiplying by 0.11298.

APPENDIX
TORQUE SPECS.

Hydraulic Torque Specifications

Straight Thread O-ring Fitting: Assembly, Fitting to Port

NOTE - Straight thread o-ring fittings are utilized to adapt hydraulic systems to motors, pumps, cylinders, and valves.



Installation (Adjustable Fitting)

1. Make sure threads and sealing surfaces are free of burrs, nicks, scratches, or any foreign materials.
2. Install proper SAE o-ring on port end of fitting if not already installed. Ensure o-ring is fully seated and retained properly.
3. Lubricate o-ring with a light coating of clean hydraulic oil.
4. Back off nut as far as possible and push washer up as far as possible. (Figure 4 & 5)
5. Screw fitting into port. Hand tighten fitting until backup washer contacts face of port. (Figure 6)
6. To position the fitting, unscrew to desired position, but not more than one full turn.
7. Hold fitting in position with wrench. Using appropriate torquing device, tighten nut to given torque rating from the table in section. (Figure 7)

Torque Values

Figures 4, 5, 6 and 7

Fitting Size	SAE Port Thread Size	In-Lbs	Ft-Lbs
-4	7/16 - 20	190 ± 10	16 ± 1
-6	9/16 - 18	420 ± 15	35 ± 1
-8	3/4 - 14	720 ± 25	60 ± 2
-10	7/8 - 14	1260 ± 50	105 ± 5
-12	1 1/16 - 12	1680 ± 75	140 ± 6
-16	1 5/16 - 12	2520 ± 100	210 ± 8
-20	1 5/8 - 12	3100 ± 150	260 ± 12
-24	1 7/8 - 12	3800 ± 150	315 ± 12

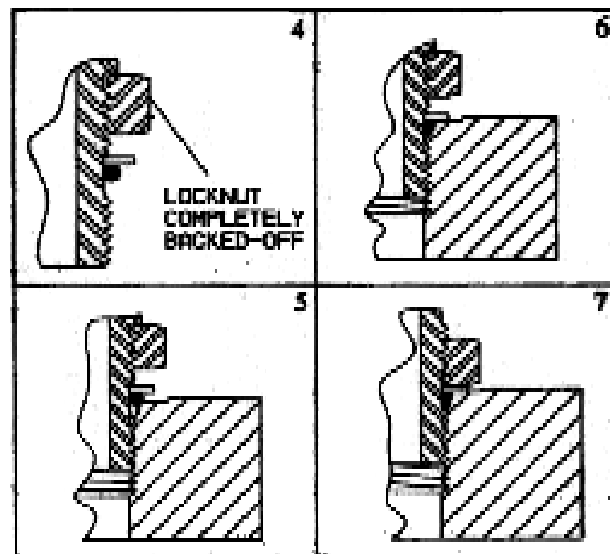

NOTE - ft-lb may be converted to NewMeters by multiplying by 1.35582.
NOTE - in-lbs may be converted to Newton Meters by multiplying by 0.11298.

Limited Warranty

Except for the Excluded Products as described below, all new products are warranted to be free from defects in material and/or workmanship during the Warranty Period, in accordance with and subject to the terms and conditions of this Limited Warranty.

1. Excluded Products. The following products are excluded from this Limited Warranty:

(a) Any cable, part that engages with the ground (i.e. sprockets), digging chain, bearing, teeth, tamping and/or demolition head, blade cutting edge, pilot bit, auger teeth and broom brush that either constitutes or is part of a product.

(b) Any product, merchandise or component that, in the opinion of Paladin Light Construction¹, has been (i) misused; (ii) modified in any unauthorized manner; (iii) altered; (iv) damaged; (v) involved in an accident; or (vi) repaired using parts not obtained through Paladin Light Construction.

2. Warranty Period. The Limited Warranty is provided only to those defects that occur during the Warranty Period, which is the period that begins on the first to occur of: (i) the date of initial purchase by an end-user, (ii) the date the product is first leased or rented, or (iii) the date that is six (6) months after the date of shipment by Paladin Light Construction as evidenced by the invoiced shipment date (the "Commencement Date") and ends on the date that is twelve (12) months after the Commencement Date.

3. Terms and Conditions of Limited Warranty. The following terms and conditions apply to the Limited Warranty hereby provided:

(a) Option to Repair or Replace. Paladin Light Construction shall have the option to repair or replace the product.

(b) Timely Repair and Notice. In order to obtain the Limited Warranty, (i) the product must be repaired within thirty (30) days from the date of failure, and (ii) a claim under the warranty must be submitted to Paladin Light Construction in writing within thirty (30) days from the date of repair.

(c) Return of Defective Part or Product. If requested by Paladin Light Construction, the alleged defective part or product shall be shipped to Paladin Light Construction at its manufacturing facility or other location specified by Paladin Light Construction, with freight PRE-PAID by the claimant, to allow Paladin Light Construction to inspect the part or product.

Claims that fail to comply with any of the above terms and conditions shall be denied.

LIMITATIONS AND EXCLUSIONS.

THIS LIMITED WARRANTY IS IN LIEU OF ALL OTHER WARRANTIES, EXPRESS OR IMPLIED, INCLUDING WITHOUT LIMITATION THE WARRANTIES OF MERCHANTABILITY, FITNESS FOR A PARTICULAR PURPOSE AND ANY WARRANTY BASED ON A COURSE OF DEALING OR USAGE OF TRADE.

IN NO EVENT SHALL PALADIN LIGHT CONSTRUCTION BE LIABLE FOR CONSEQUENTIAL OR SPECIAL DAMAGES.

IN NO EVENT SHALL PALADIN LIGHT CONSTRUCTION BE LIABLE FOR ANY LOSS OR CLAIM IN AN AMOUNT IN EXCESS OF THE PURCHASE PRICE, OR, AT THE OPTION OF PALADIN LIGHT CONSTRUCTION, THE REPAIR OR REPLACEMENT, OF THE PARTICULAR PRODUCT ON WHICH ANY CLAIM OF LOSS OR DAMAGE IS BASED. THIS LIMITATION OF LIABILITY APPLIES IRRESPECTIVE OF WHETHER THE CLAIM IS BASED ON BREACH OF CONTRACT, BREACH OF WARRANTY, NEGLIGENCE OR OTHER CAUSE AND WHETHER THE ALLEGED DEFECT IS DISCOVERABLE OR LATENT.

¹Attachment Technologies Inc., a subsidiary of Paladin Brands Holding, Inc. (PBHI) is referred to herein as Paladin Light Construction.