



# QC Series

210 Series

**Hydraulic Windrow Sweepers  
for Skid Loaders**



**PALADIN**  
LIGHT CONSTRUCTION GROUP



*The Power of Combined Excellence*



Sweepster Serial Number \_\_\_\_\_

Manual Number: 51-3880  
Release Date: November 3, 2008  
Serial Number 0733001 and Up



# Table of Contents

<b>Section 1 ... Installation.....</b>	<b>5-13</b>
<b>Section 2 ... Operation and Maintenance .....</b>	<b>15-23</b>
<b>Section 3 ... Service.....</b>	<b>25-30</b>
<b>Section 4 ... Parts.....</b>	<b>31-43</b>
<b>Section 5 ... Options .....</b>	<b>45-54</b>
<b>Section 6 ... Appendix .....</b>	<b>54-61</b>



---

# Installation Manual

---

## QC Series Angle Brooms

---

### Table of Contents

Introduction .....	6
<b>Safety Information .....</b>	<b>7-13</b>
General Safety Information .....	7-8
Safety Signs & Labels .....	10-11
Product Information Section.....	12
Installation/Storage .....	13

---

# Introduction

## Importance of this Manual

 Read this manual before attempting to operate the equipment.

This operator's manual should be regarded as part of the sweeper. Suppliers of both new and secondhand sweepers are advised to keep documentation indicating that this manual was provided with the sweeper.

The manual contains information regarding installation, operation and maintenance required for this sweeper and optional equipment. It also includes detailed parts lists.

---

## Purpose of Sweeper

This sweeper is designed solely for use in construction cleanup, road maintenance, grounds maintenance and similar operations. Use in any other way is considered contrary to the intended use. Compliance with and strict adherence to operation, service and repair conditions, as specified by the manufacturer, are also essential elements of the intended use.

This sweeper should be operated, serviced and repaired only by persons who are familiar with its characteristics and acquainted with relevant safety procedures.

Accident prevention regulations, all other generally recognized safety regulations and all road traffic regulations must be observed at all times.

Any modifications made to this sweeper may relieve the manufacturer of liability for any resulting damage or injury.

---

## Safety Alert Symbol

 This safety alert symbol indicates important safety messages in this manual. When you see this symbol, be alert to the possibility of injury. Carefully read the message that follows and inform other operators.

---

## Contacting SWEEPSTER

If you have any questions about information in this manual or need to order parts, please call, write, fax or e-mail SWEEPSTER.

SWEEPSTER  
2800 North Zeeb Road  
Dexter, Michigan 48130  
Phone: (734) 996-9116 - (800) 456-7100  
FAX: (734) 996-9014  
e-mail: [sweepster@paladinbrands.com](mailto:sweepster@paladinbrands.com)

For help with installation, operation or maintenance procedures, contact our Technical Service Department. Direct product questions and parts orders to our Sales Department.

When ordering parts or accessories, be prepared to give the following information:

- Sweeper model, serial number and date of purchase
- Prime mover, make and model
- Part number, description and quantity

---

## Terms Used in Manual

*Right-hand, left-hand, front and rear* are determined from the operator's perspective (either the operator's seat or standing behind a walk-behind unit), facing forward in the normal operating position.

*Prime mover* refers to the tractor, truck, loader or tow vehicle that the sweeper is mounted on or towed by.

---

## Optional Equipment

Installation instructions for optional equipment, if applicable, appear in the Service Manual Section.

---

## Specifications & Features

Due to continuous product improvement, specifications and features may change without notice.

---

## Warranty

To validate the warranty for this unit, fill out the warranty card or warranty pages located at the back of this manual. Then, send this information to SWEEPSTER.

# Safety Information

## Read this manual

*Read all safety information in this manual. All operators must read and understand the entire contents of this manual before sweeping. General safety practices are listed on Safety Information pages and specific safety information is located throughout this manual.*

## Hazard Definitions

Four hazard classifications are used in this manual. They are



**DANGER** - Indicates an imminently hazardous situation which, if not avoided, will result in death or serious injury.



**WARNING** - Indicates a potentially hazardous situation which, if not avoided, could result in death or serious injury.



**CAUTION** - Indicates a potentially hazardous situation which, if not avoided, may result in minor or moderate injury.

**NOTICE** - Used for instructions when machine damage may be involved.

## Operation



**CAUTION** - A sweeper is a demanding machine. Only fully trained operators or trainee operators under the close supervision of a fully trained person should use this machine.

Before operating sweeper:

- Learn sweeper and prime mover controls in an off-road location.
- Be sure that you are in a safe area, away from traffic or other hazards.
- Check all hardware holding the sweeper to the prime mover, making sure it is tight.
- Replace any damaged or fatigued hardware with properly rated fasteners. See Maintenance Section
- Make sure all hydraulic hardware and hydraulic fittings are tight.
- Replace any damaged or fatigued fittings or hoses.

- Check prime mover tire pressure before sweeping.
- Check tire ratings to be sure they match the prime mover load. Weigh the sweeper end of the prime mover, if necessary, to insure proper tire rating.
- Remove from the sweeping area all property that could be damaged by flying debris.
- Be sure all persons not operating the sweeper are clear of the sweeper discharge area.
- Always wear proper apparel such as a long-sleeved shirt buttoned at the cuffs; safety glasses, goggles or a face shield; ear protection; and a dust mask.

While operating sweeper:

• When operating sweeper, adhere to all government rules, local laws and other professional guidelines for your sweeping application.



**WARNING** - Never raise the sweeper more than a few feet off the ground. The sweeper can tip back or the prime mover can tip over causing death or serious injury,

- Before leaving the operator's area for any reason, lower the sweeper to the ground. Stop the prime mover engine, set the parking brake and remove the key from the ignition.
- Minimize flying debris - use the slowest rotating speed that will do the job. See Operation Section: Operating Tips
- Keep hands, feet, hair and loose clothing away from all moving parts.
- Leave the brush hood (shield) and all other shields and safety equipment in place when operating the sweeper and prime mover.
- Be aware of the extra weight and width a sweeper adds. Reduce travel speed accordingly. See Product Information Section: Operating the Sweeper.
- When sweeping on rough terrain, reduce speed to avoid "bouncing" the sweeper. Loss of steering can result.
- Never sweep toward people, buildings, vehicles or other objects that can be damaged by flying debris.
- Only operate the sweeper while you are in the operating position. The safety restraint must be fastened while you operate the prime mover. Only operate the controls while the engine is running. Protective glasses must be worn while you operate the prime mover and while you operate the sweeper.
- While you operate the sweeper slowly in an open area, check for proper operation of all controls and all protective devices. Note any needed repairs during operation of the sweeper. Report any needed repairs.

SAFETY SECTION  
GENERAL SAFETY INFORMATION

---

### Service & Repair - General



**CAUTION** - Do not modify the sweeper in any way. Personal injury could result. If you have questions, contact your dealer or SWEEPSTER.

Repair or adjust the sweeper in a safe area, away from traffic and other hazards.

Before adjusting or servicing - lower the sweeper to the ground, set parking brake, shut down the prime mover and remove the key from the ignition.

When working on or around the sweeper, safely secure it from falling or shifting.

### Service & Repair - Hydraulic Safety

Stop the prime mover engine and release hydraulic pressure before servicing or adjusting sweeper hydraulic systems.



**WARNING** - Escaping hydraulic fluid can have enough pressure to penetrate the skin, causing serious personal injury.

Check lines, tubes and hoses carefully. Do not use your hand to check for leaks. Use a board or cardboard to check for leaks. Tighten all connections to the recommended torque. See Appendix.

Do not bend high pressure lines. Do not strike high pressure lines, Do not install bent lines, bent tubes, or kinked hoses. Do not install damaged lines, damaged tubes, or damaged hoses.

Repair loose lines, loose tubes, and loose hoses. Repair damaged lines, damaged tubes, and damaged hoses. Leaks can cause fires. See your SWEEPSTER dealer for repair or replacement parts.

Replace the parts if any of the following conditions are present:

- The end fittings are damaged or leaking.
- The outer covering is chafed or cut.
- The reinforcing wire layer is exposed.
- The outer covering is ballooning locally.
- The hose is kinked or crushed.
- The hoses have been pulled or stretched.

Make sure that all clamps, guards, and shields are installed correctly.

---



# Notes

---

SAFETY SECTION  
SAFETY SIGNS & LABELS

## Safety Signs and Labels

There are several specific safety signs on this sweeper. The exact location of the hazards and the description of the hazards are reviewed in this section.

### Placement or Replacement of Safety Signs

1. Clean the area of application with nonflammable solvent, and then wash the same area with soap and water.
2. Allow the surface to fully dry.
3. Remove the backing from the safety sign, exposing the adhesive surface.
4. Apply the safety sign to the position shown in the diagram above and smooth out any bubbles.

### Instructions

- Keep all safety signs clean and legible.
- Replace all missing, illegible, or damaged safety signs.
- Replacement parts, for parts with safety signs attached, must also have safety signs attached.
- Safety signs are available, free of charge, from your dealer or from SWEEPSTER.

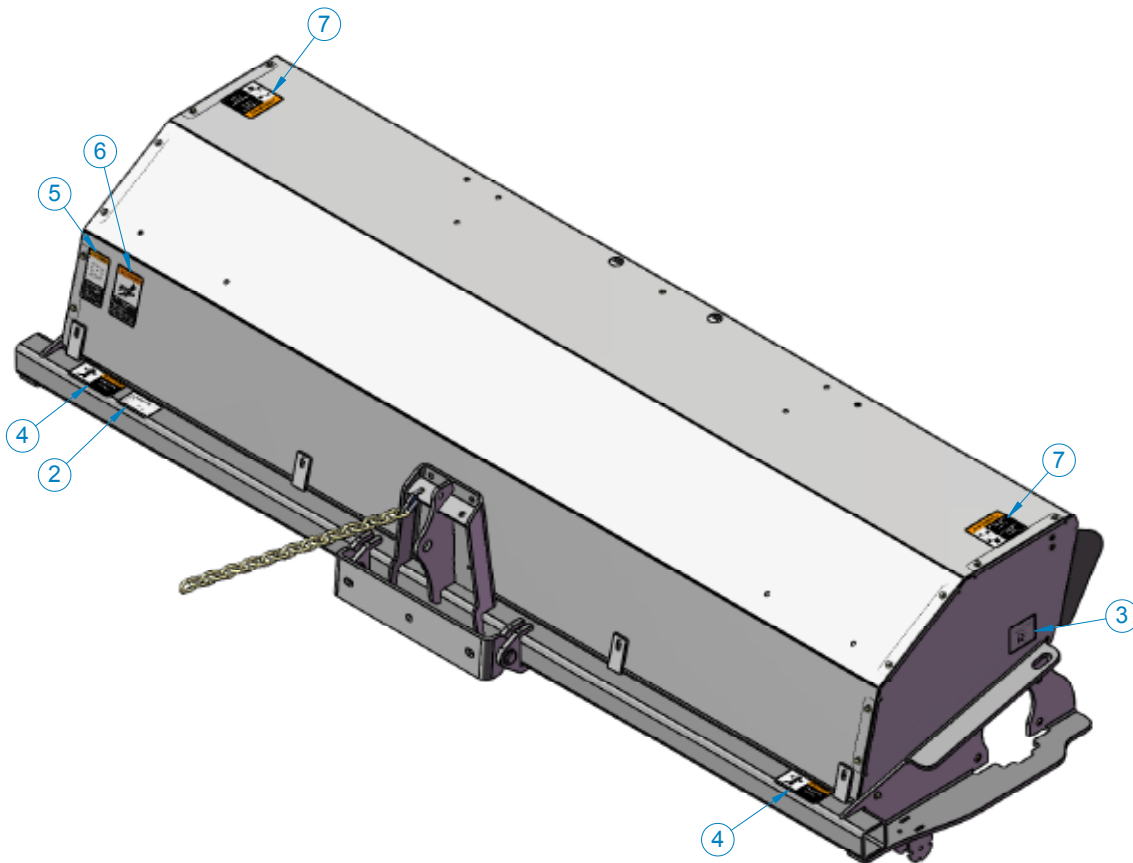

Item	Part Qty	Description
2.	50-0634 1	Label, Serial Number
3.	50-0643 2	Label, Tie Down Point
4.	50-0721 2	Label, Warning, Crush Hazard
5.	50-0722 1	Label, Warning, Misuse Hazard
6.	50-0724 1	Label, Warning, High Pressure Fluid Hazard
7.	50-0726 2	Label, Warning, Flying Objects & Entanglement

Safety Signs and Labels



2. 50-0634

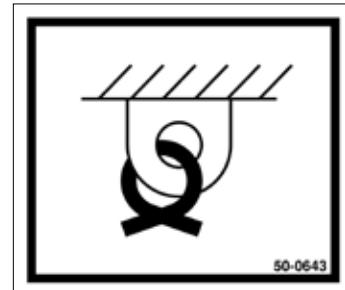

3. 50-0643



4. 50-0721

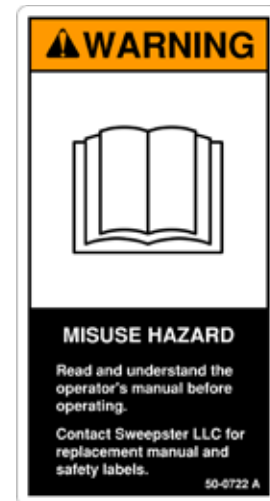

5. 50-0722



6. 50-0724



7. 50-0726

# Product Information Section

## Specifications and Model Views

Maximum Width at 0° Articulation

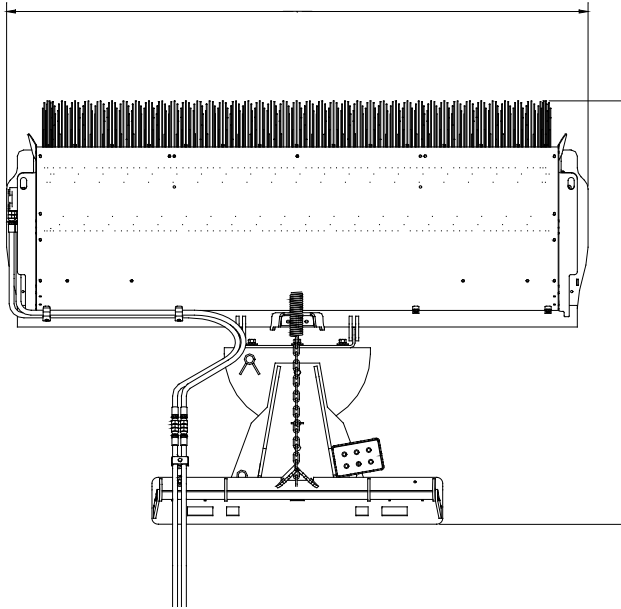

Maximum Length at 0° Articulation

Maximum Width at Full Articulation

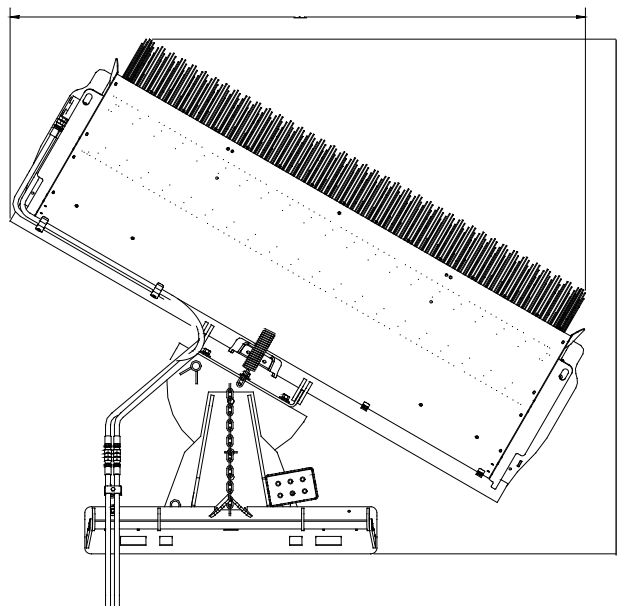

Maximum Length at Full Articulation

QC Brush Head			
	Single Motor	Dual Motor	
Approximate Weight with SAE J2513 Mounting	793 lbs	829 lbs	5 Ft
	852 lbs	890 lbs	6 Ft
	915 lbs	953 lbs	7 Ft
	982 lbs	1022 lbs	8 Ft
Maximum Length at 0° Articulation	71 inches with SAE J2513 Mounting		
Maximum Width at 0° Articulation	70.5 inches	5 Ft	
	82.5 inches	6 Ft	
	94.5 inches	7 Ft	
	106.5 inches	8 Ft	
Maximum Length at Full Articulation	79.5 inches	5 Ft	
	82.5 inches	6 Ft	
	85.5 inches	7 Ft	
	88.5 inches	8 Ft	
Maximum Width at Full Articulation	72 inches	5 Ft	
	82 inches	6 Ft	
	93 inches	7 Ft	
	103 inches	8 Ft	
Sweeping Width at 0° Articulation	60 inches	5 Ft	
	72 inches	6 Ft	
	84 inches	7 Ft	
	96 inches	8 Ft	
Sweeping Width at Full Articulation	54 inches	5 Ft	
	64 inches	6 Ft	
	75 inches	7 Ft	
	85 inches	8 Ft	

Range of Hydraulic Oil Flow		
Single Motor	18 cubic inch	10-18
Single Motor	25 cubic inch	12-25
Dual Motor	18 cubic inch	18-36
Maximum Hydraulic Oil Pressure		
Single Motor	18 cubic inch	3500 psi
Single Motor	25 cubic inch	3000 psi
Dual Motor	18 cubic inch	3500 psi

## Sweeper Installation (Broom to Prime Mover)



**WARNING** - Improper attachment of sweeper could result in injury or death. Do not operate this machine until you have positive indication that the attachment is securely mounted.

1. Position the broom on a level surface.
2. Enter the prime mover.
3. Fasten the safety restraints.
4. Start the engine.
5. Disengage the parking brake.
6. Align the attachment mechanism with the mounting on the broom, attach to the prime mover. Follow the attaching procedure in the prime mover owners manual.
7. Engage the parking brake and shut down the prime mover. Be sure to relieve pressure to the auxiliary hydraulic lines.
8. Unfasten safety restraints and exit the prime mover.
9. Lock jack stands in stowed position. (if available)
10. Ensure that the hydraulic quick couplers are clean. Connect hydraulic lines for the broom to the prime mover. Twist the collar of the quick couplers one quarter of a turn in order to secure the hydraulic connections.
11. While the loader arms are lowered, visually inspect the attachment mechanism to ensure that it is securely mounted.
12. Enter prime mover, fasten safety restraints and start the prime mover.
13. Carefully raise the loader and cycle the rollback/dump cylinders to check clearances, that limiting stops make proper contact and verify that all mounting procedures have been successfully completed. Contact SWEEPSTER for instructions if the limiting stops do not contact properly.

## Removing the Sweeper



**WARNING** - Serious injury or death may result from disengaging the sweeper when the sweeper is in an unstable position or carrying a load. Place the sweeper in a stable position before disengaging.

**NOTICE** - Hoses for the sweepers must be removed before the quick attach is disengaged. Pulling the sweeper with the hoses could result in damage to the prime mover or the sweeper.

1. Lower the broom to the ground.
2. Engage the parking brake and shut down the prime mover. Be sure to relieve pressure to the auxiliary hydraulic lines.
3. Unfasten safety restraints and exit prime mover.
4. Lock jack stands in lowered position. (if available)
5. Disconnect the broom hydraulic lines from the prime mover. Connect quick couplers together to keep clean.
6. Disengage attachment locking mechanism. (mechanical type)
7. Enter prime mover, fasten safety restraints and start the prime mover.
8. Disengage attachment mechanism. (hydraulic type)
9. Disengage the parking brake, and back away from the broom.

## Storage

**NOTICE** - Do not store the sweeper with weight on the brush. Weight will deform the bristles, destroying the sweeping effectiveness. To avoid this problem, place the sweeper on blocks or use storage stands.

Do not store polypropylene brushes in direct sunlight. The material can deteriorate and crumble before the bristles are worn out.

Keep polypropylene brush material away from intense heat or flame.

# Notes

---

---

# Operation and Maintenance Manual

---

## QC Series Angle Brooms

---

### Table of Contents

<b>Operation.....</b>	<b>16-18</b>
Operation .....	16
Leveling Sweeper .....	17-18
<b>Maintenance.....</b>	<b>19-23</b>
Brush Pattern Adjustment .....	19
Maintenance Schedule .....	20
Maintenance Record.....	21
Replacing Brush Sections.....	22
Lubrication Points .....	23

## OPERATION SECTION SWEEPING/OPERATING TIPS

---

### Before Each Use

Perform daily maintenance as indicated in Maintenance Schedule.

Run the prime mover and sweeper at a slow idle. Check for hydraulic leaks or other problems and make corrections, if necessary, before using the sweeper. See "Hydraulic inspection guideline".



**WARNING** - Avoid serious injury. Check for large objects that could harm the operator or others if thrown by the sweeper. Remove these items before operating.

### During Use

#### Directing Debris

Carry the sweeper low to the ground so that the operator has good visibility and stability. Avoid any sudden movements.

Avoid excessive downward pressure on the brush sections to prevent excessive wear. A two to four inch wide pattern is sufficient for most applications. Ensure that the adjustment bolts are equally adjusted in order to prevent an uneven wear pattern. To adjust brush pattern see "Adjusting Brush Pattern".

Direct debris by angling the brush head in that direction.

Observe wind direction. Sweeping with the wind makes sweeping more effective and helps keep debris off the operator.

The terms swing and angle are used interchangeably.

#### Manual Angle

1. Remove the quick release pin from the swing plate.
2. Position the brush head at the desired angle, aligning holes in the swing plate and mounting frame.
3. Re-insert the quick release pin.

#### Hydraulic Angle

1. Start the prime mover.
2. Position the brush head at the desired angle by using

### Sweeping

To sweep:

1. Manual angle only - Swing the brush head assembly the direction that you want to direct debris.
2. Start the prime mover at idle and raise the brush.
3. Hydraulic angle only - Swing the brush head assembly the direction that you want to direct debris.

4. Engage the brush and then lower it to the ground.
5. Increase prime mover engine rpm to sweeping speed.
6. Travel forward at 5 mph (8 kph) or less.

**NOTICE** - Avoid sweeper damage. Reduce travel speed to avoid hitting immovable objects.

---

### Operating Tips

**NOTICE**- Avoid sweeper damage. Do not ram into piles. Use an appropriate attachment for this type of job.

#### Brush, Engine & Travel Speeds

Vary brush, engine and travel speeds to match sweeping conditions.

#### Large Areas

When sweeping a large area, such as a parking lot, make a path down the middle and sweep to both sides. This reduces the amount of debris that the sweeper must sweep to one side.

#### Snow

Fast brush speeds and slow travel speeds are needed to sweep snow effectively. Start at 3/4 throttle and the lowest gear of the prime mover. For wet and/or deep snow, increase to almost full throttle. This helps keep snow from packing up inside the brush hood.

In deep snow you may need to make multiple passes to get down to a clean surface.

To keep snow from blowing back onto a swept area, always sweep so the wind is at your back.

#### Dirt & Gravel

To keep dust at a minimum, use the optional dust suppression kit or plan sweeping for days when it is overcast and humid or after it has rained. Also, sweep so the wind blows at your back.

Low brush speeds and moderate travel speeds work best for cleaning debris from hard surfaces. Brush speeds that are too fast tend to raise dust because of the aggressive sweeper action.

To sweep gravel, use just enough brush speed to "roll" the gravel, not throw it.

#### Heavy Debris

Travel slowly - 2-3 mph. (3-5 kph)

Sweep a path less than the full width of the sweeper.

Increase engine speed if debris becomes very heavy.

---



## Leveling

Level the sweeper for even brush wear and effective use.



**CAUTION** - Avoid injury. Before adjusting the sweeper, always turn off the sweeper and the prime mover engine and remove the key.

1. Move the sweeper to a flat, paved surface.
2. Lower the brush head assembly so the brush is 2 inches (51 mm) above the ground.
3. Engage the parking brake and shut down the prime mover. Be sure to relieve pressure to the auxiliary hydraulic lines.
4. Unfasten safety restraints and exit prime mover.
5. Check if the swing assembly is level by using a bubble level. To make corrections: Adjust tilt cylinders. If the front of the swing assembly is high, extend tilt cylinders. If low, retract cylinders.
6. Position the brush head assembly straight ahead. On each side, measure from the brush frame to the ground (figure 1). If measurements are not equal:

Loosen hardware that attaches the swing assembly to the brush head assembly; lower the high side of the brush head until both sides are an equal distance above the ground. Tighten the hardware. (figure 2)

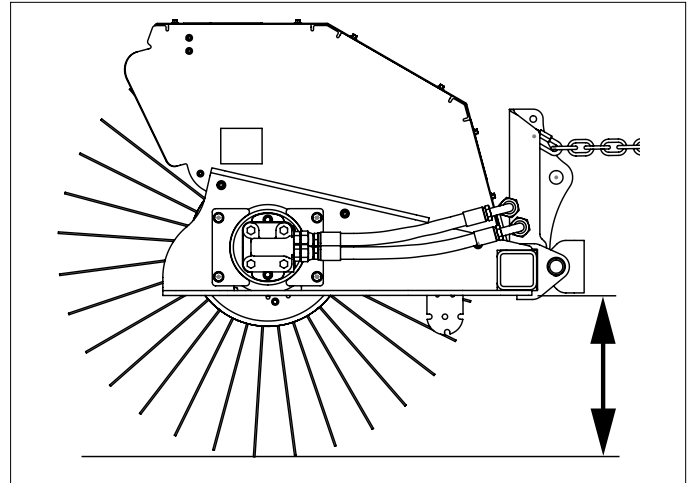

figure 1

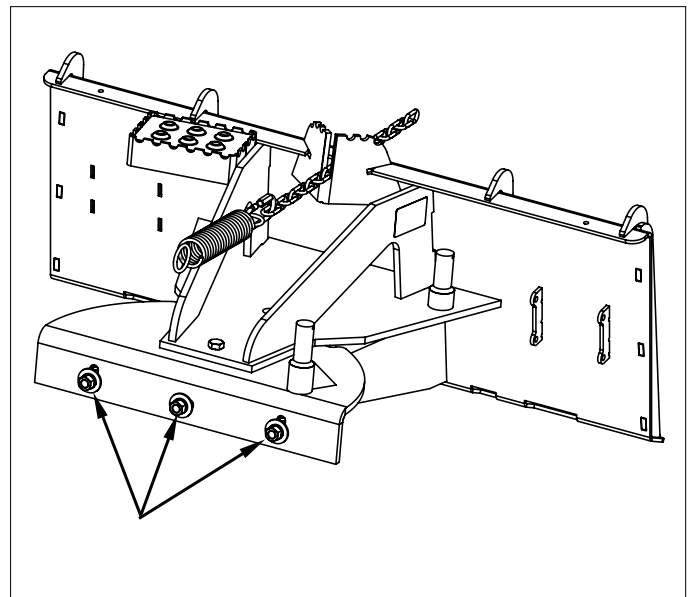

figure 2

MAINTENANCE SECTION  
LEVELING THE SWEEPER

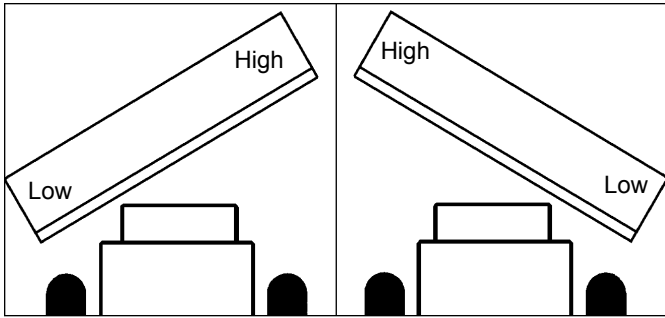

figure 3

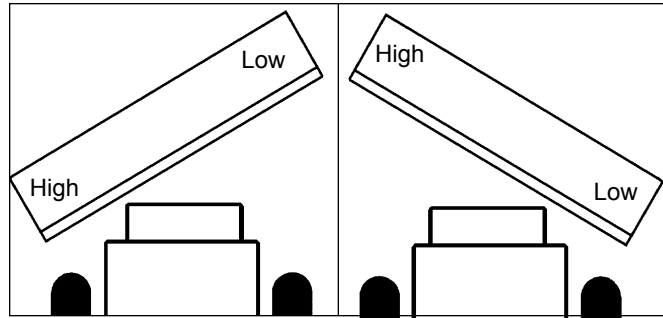

figure 5

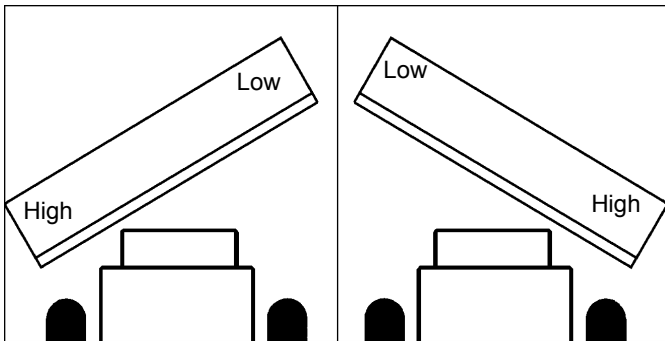

figure 4

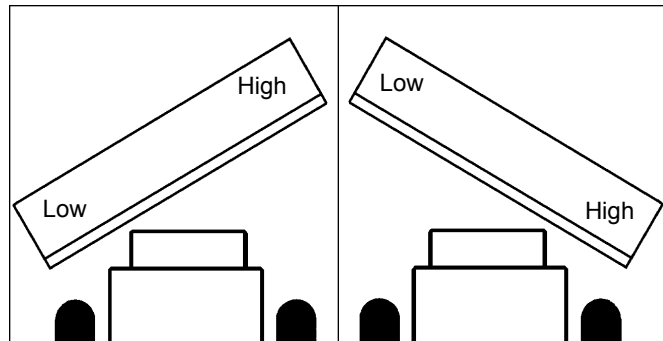

figure 6

7. Measure to see if the brush head assembly is level when angled. First, angle the brush head to the right. Measure as in step 4. Then, angle the brush head to the left. Measure again. If measurements are equal, the sweeper is level. If not, proceed with this step.

To correct leveling problems shown in:

- figure 3, extend tilt cylinders.
- figure 4, retract tilt cylinders.
- figure 5, loosen hardware that attaches the swing assembly to the brush head assembly; lower the left-hand side of the brush head until both sides are an equal distance above the ground. Tighten the hardware.
- figure 6, loosen hardware that attaches the swing assembly to the brush head assembly; lower the right-hand side of the brush head until both sides are an equal distance above the ground. Tighten the hardware.

## Setting Brush Pattern

A properly adjusted brush offers the best sweeper performance. To check the brush pattern:

1. Move the sweeper to a dusty, flat surface.
2. Set the prime mover's parking brake and leave the engine running.
3. Start the sweeper at a slow speed: lower it so the bristle tips touch the ground. Run the sweeper in a stationary position for 10 seconds.
4. Raise the sweeper and back away; switch off the engine and remove the key. The brush pattern left in the dust should be 2-4 inches (51-102 mm) wide, running the length of the brush. (Compare the swept area with figure 7.)
5. Adjust the brush pattern as necessary according to instructions found in adjusting the Spring-Chain Assembly.

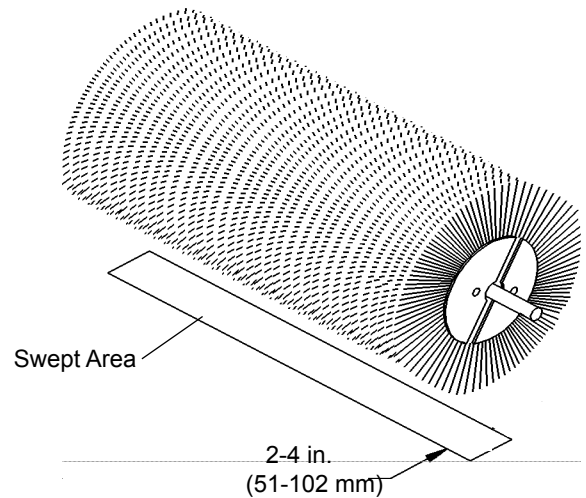

Figure 7

## Adjusting Spring-Chain Assembly

The spring-chain assembly allows the brush head to pivot up and down.

To adjust the brush pattern:

1. Lower the sweeper.
2. Tighten the transport chain and lower the sweeper so the transport chain supports weight.
3. Move the spring chain forward in the swing assembly chain holder to lower the brush head or backward in the holder to raise it.

## Tightening Transport Chain

The transport chain supports the weight of the brush head assembly during transport between work sites and during adjustment of the spring-chain assemblies.

To adjust the transport chain:

1. Extend tilt cylinders.
  2. Tighten the transport chain.
  3. Retract tilt cylinders.
-

MAINTENANCE SECTION  
 MAINTENANCE SCHEDULE

**Maintenance Schedule**

Procedure	Before Each Use	After Each Use	100 Hours	500 Hours	See Prime Mover Manual
<b>Brush head assembly</b> - Level	✓				
<b>Brush pattern</b> - Check (See Pattern Adj. Section)	✓				
<b>Cylinders</b> - Retract rods		✓			
- Grease threaded and ball ends to prevent rust		✓			
<b>Filter, air, prime mover</b> - Clean					✓
<b>Fittings/hoses, hydraulic</b> - Check for leaks/tighten Check for damage	✓				
<b>Fittings, zerk</b> - Grease. (See lubrication points)	✓				
<b>Oil, hydraulic</b> - Check Level	✓				
<b>Hardware</b> - Check for tightness	✓				



MAINTENANCE SECTION  
REPLACING BRUSH SECTIONS

## Replacing Brush Sections

1. Remove motor mount screws. Retain hardware for reinstallation. Remove motor mount.
2. Remove bearing mounting plate screws from side. Retain hardware for reinstallation.
3. Remove core from brush head assembly.
4. Remove one half of bearing mount plate from bearing.
5. Remove retaining plate from core assembly.
6. Remove old sections.
7. Install new sections by doing the following:
  - a. Slide the first section onto the core with the drive pins on each side of a tube. Make sure that the drive pins angle up. (figure 1)
  - b. Install a second section with drive pins rotated 180° from those on the first section. ( figure 2)
  - c. Continue installing sections, rotating each section 180° until the core is full.
8. Reattach the section retainer and bearing mounting plate with previously removed hardware.
9. Lay core on ground. Lower frame over core.
10. Reattach bearing mounting plate with previously removed hardware.
11. Reattach motor mount with hardware removed in first step.

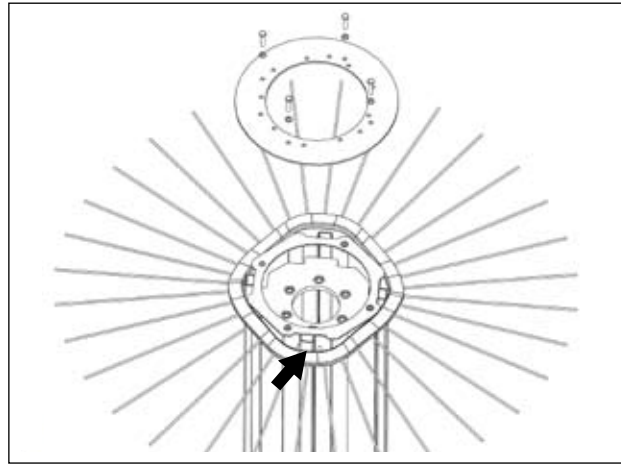

figure 1

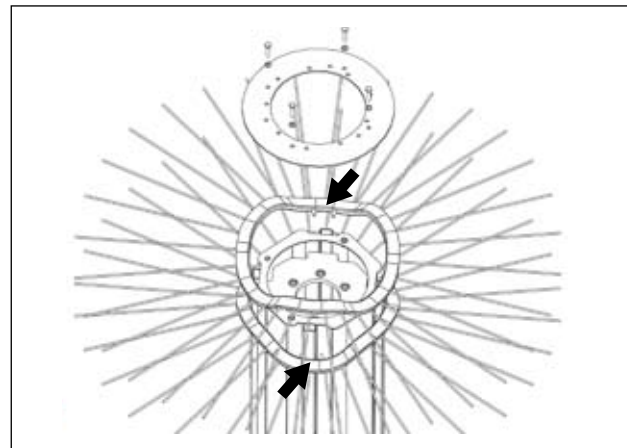
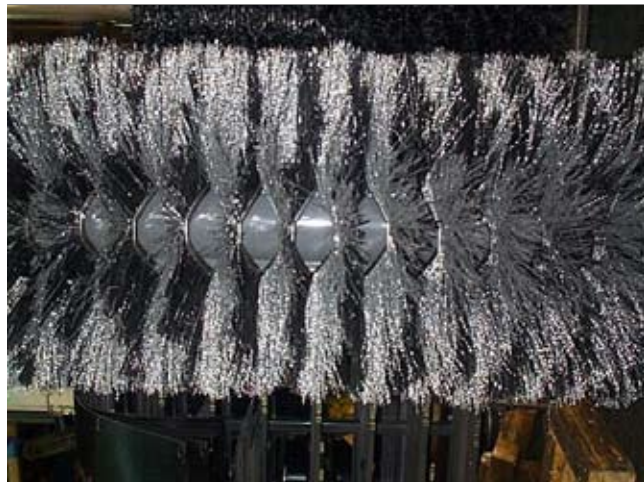

figure 2



## Lubrication Points

The following grease fittings should be greased before each use. See figure for locations.

1. Core bearing (1 fitting - single motor only)
2. Brush Head Pivot (2 fitting)

Not Shown:  
Hydraulic Angle Cylinder (1 fitting)

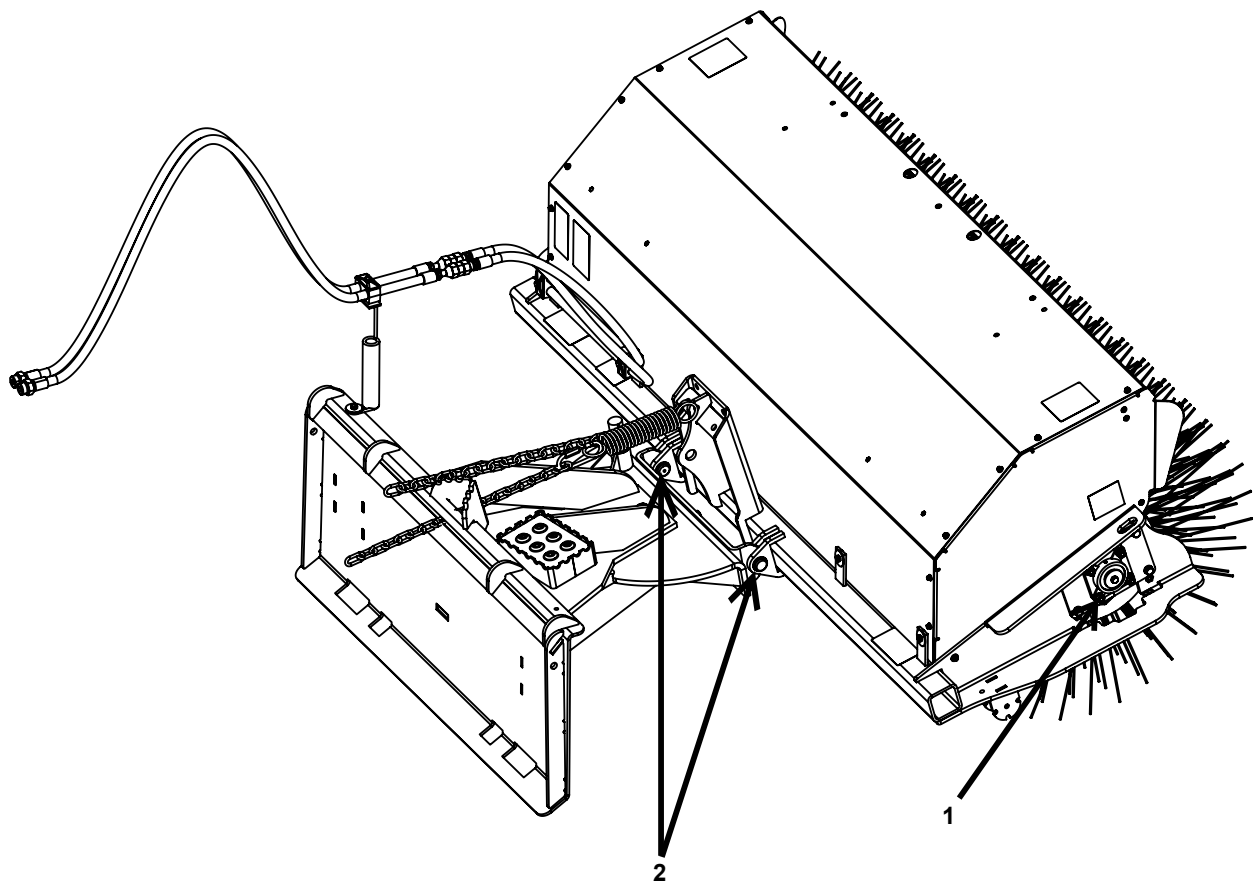

# Notes

---



---

# Service Manual

---

## QC Series Angle Brooms

---

### Table of Contents

<b>Troubleshooting .....</b>	<b>26-30</b>
Brush Head .....	26
Spring-Chain .....	27
Lift & Swing .....	27
Hydraulic System .....	28
Hydraulic Hose Routing .....	29
Wiring Harness .....	30

SERVICE SECTION  
TROUBLESHOOTING

---

**Brush Head**

<b>Problem</b>	<b>Possible Cause</b>	<b>Possible Solution</b>
Brush rotates in wrong direction	Hoses installed incorrectly	Switch hoses at brush head tubes
Brush slows or stops when sweeping	Brush pattern too wide	Adjust brush pattern to 2-4 inches (51-101mm) wide: see Maintenance: Adjusting Brush Pattern
	Travel speed too fast	Travel no more than 5 mph (8 kph) while sweeping (2-3 mph recommended)
	Trying to sweep too much material at once	Make several passes with sweeper
	Relief pressure set too low	Set relief pressure to 2000 psi (138.0 bars)
	Filter plugging	Change or clean hydraulic oil filter
Brush head assembly "bounces" during sweeping	Travel speed too fast and/or brush speed too slow	Find correct combination of ground and brush speeds: do not travel at more than 5 mph (8 kph)
Brush wears into cone shape	Sweeper is not level	Level sweeper before each use: see Maintenance: Leveling
	Tires on prime mover at different pressures or are different sizes	Check tire sizes and rating: make corrections as necessary
Brush wears very quickly	Brush pattern too wide	Adjust brush pattern to 2-4 inches (51-101mm) wide: see Maintenance: Setting Brush Pattern

**Spring-Chain Assemblies**

<b>Problem</b>	<b>Possible Cause</b>	<b>Possible Solution</b>
Springs on spring-chain assemblies stretching	Transport chain too loose when traveling between job sites	Adjust according to Adjustment: Transport Chain
	Travel speeds too fast when sweeping	Do not travel at speeds over 5 mph (8 kph).

**Hydraulic Cylinders - Lift & Swing**

<b>Problem</b>	<b>Possible Cause</b>	<b>Possible Solution</b>
Hydraulic cylinder neither extends nor retracts	<u>Manual valve</u> - Control rods not connected or are binding	Check control rod linkage; make sure all parts are connected and are not binding; fix if necessary
	<u>Electric valve</u> - No power from controls because wires are broken or disconnected	Reconnect wires if disconnected; replace wires if broken
	<u>Electric valve</u> - No power from controls because switch is broken	Replace switch
	<u>Both types of valves</u> - Hydraulic oil level too low	Fill tank to 2-3 inches (51-76mm) from top of tank with ISO VG-46 oil
	<u>Both types of valves</u> - Hoses or fittings loose or disconnected	Tighten hoses and fittings
	<u>Both types of valves</u> - Restriction in hoses	Remove bends in hoses, remove obstructions inside hoses
Hydraulic cylinder only extends or only retracts	<u>Electric valve</u> - Set screw in flow divider on manifold out of adjustment	Loosen jam nut and then turn set screw in until it stops; turn set screw out 1 1/2 turns; tighten jam nut
	<u>Electric valve</u> - Dirt or debris in spools	Contact Sweepster Technical Service
Hydraulic cylinder extends or retracts too quickly	<u>Manual valve</u> - Flow too high because restrictor fitting missing from cylinder	Reinstall restrictor fitting on barrel end of cylinder
	<u>Manual valve</u> - Flow too high even though restrictor fitting is installed	Contact Sweepster for smaller orifice fitting

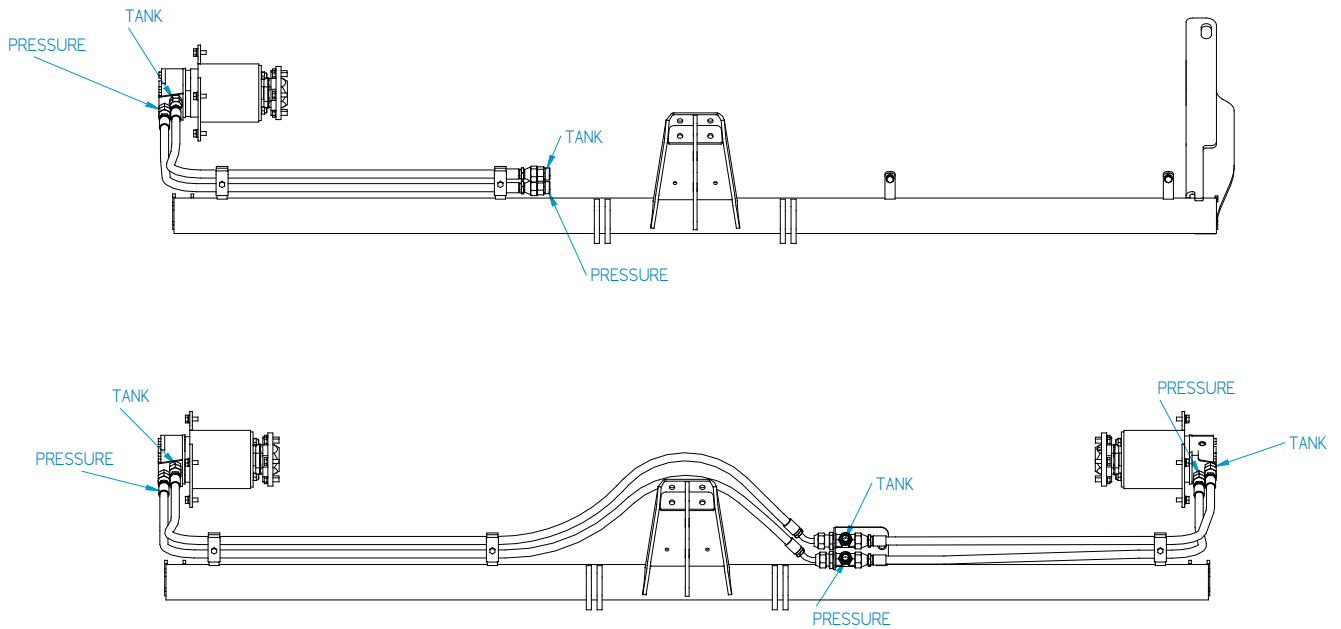

**Hydraulic Hose Routings**

**Manual Angle:** Connect pressure line to female quick disconnect. Connect return line to male quick disconnect.

**Hydraulic Angle:** Connect pressure line to female quick disconnect. Connect return line from brush motor(s) to "P" port on manifold. Connect "T" port on manifold to male quick disconnect.

**Note:**  
Quick Disconnect Set-Up

Your broom comes equipped with standard ISO 16028 hydraulic quick disconnects (QD's). They are factory installed using the broom female QD as the detented pressure line. If your skid steer loader male QD is not the detented pressure line you will need to swap the positions of the broom QD's.

SERVICE SECTION  
TROUBLESHOOTING

Wiring Harness

WIRE NO.		APPLICATION	
GUAGE	IDENTIFICATION	FROM	TO
1A	16 BLACK	BATTERY +2V	SPADE TERMINAL (MALE)
1B	16 BLACK	PACKARD CONN. PIN F	SPADE TERMINAL (FEMALE)
2A	16 RED	BATTERY +	CIRCUIT BREAKER 10A - BATT
2B	16 RED	CIRCUIT BREAKER 10A - AUX	SWITCH 1-A
3	16 RED	PACKARD CONN. PIN BDEPTH	SWITCH 1-B
4	16 YELLOW	PACKARD CONN. PIN C-TILT	SWITCH 1-C

LAF9444 WIRE HARNESS

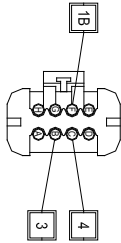

PLUG - A, D, E, G & H  
VIEW "A-A"

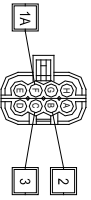

A, D, E, G, H PLUG

- | Item | Part    | Qty | Description     |
|------|---------|-----|-----------------|
| 1.   | 07-3152 | 1   | Circuit Breaker |
| 2.   | 07-0868 | 1   | Switch          |
| 3.   | 07-1824 | 1   | Rubber Boot     |

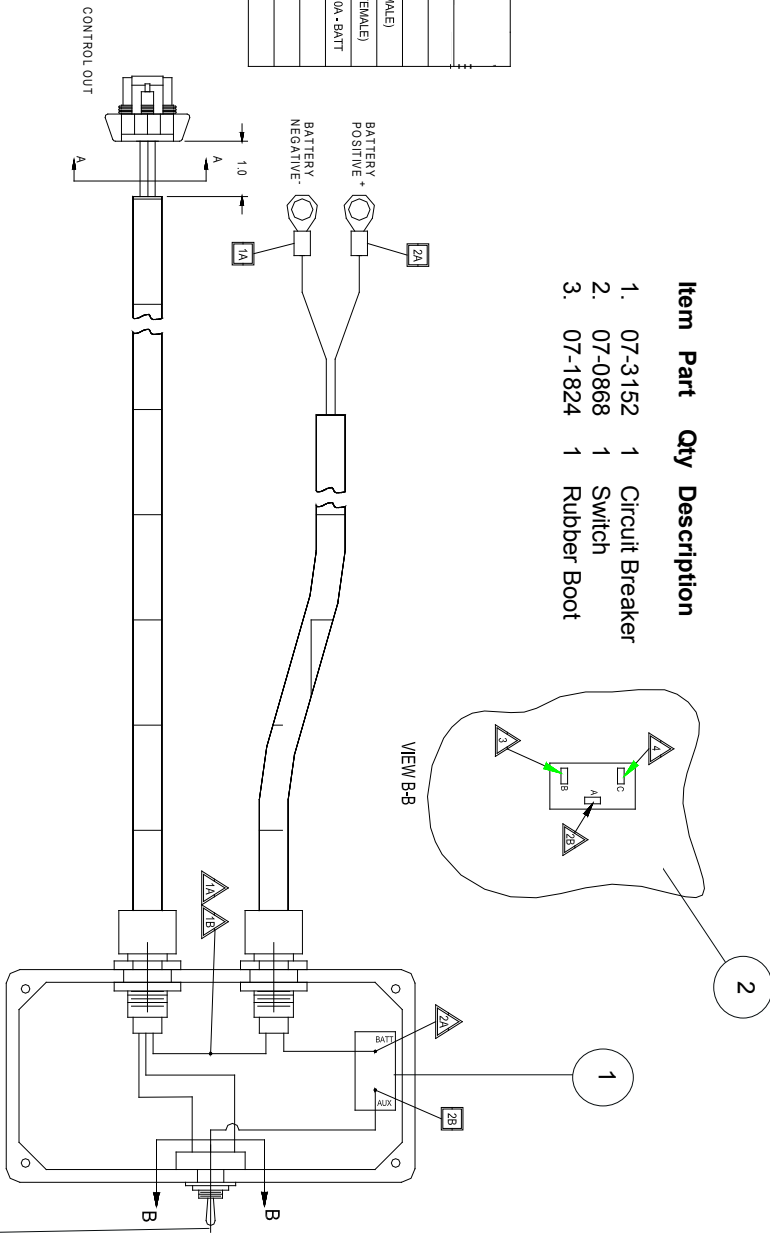

WIRE NO.		APPLICATION	
GUAGE	IDENTIFICATION	FROM	TO
1A	16 BLACK	PACKARD PIN F	ULTRA SONIC SPICE
1B	16 BLACK	ULTRA SONIC SPICE	PACKARD 1 PIN B
1C	16 BLACK	ULTRA SONIC SPICE	PACKARD 2 PIN B
2	16 RED	PACKARD PIN B	PACKARD 1 PIN A
3	16 YELLOW	PACKARD PIN C	PACKARD 2 PIN A

LAF9441 WIRE HARNESS

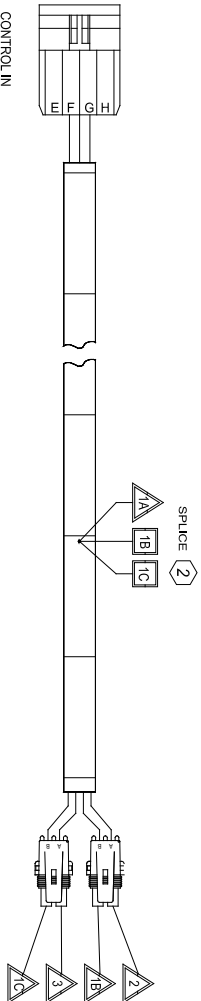

SPICE (2)

VIEW B-B

---

# Parts Manual

---

## QC Series Angle Brooms

---

### Table of Contents

#### Parts Lists .....32-43

Brush Head Frames.....	32
Core Assemblies.....	33
Shaft Assembly.....	34
Motor Bucket Assembly.....	35
Hydraulics-Dual Motor.....	36-38
Hydraulics-Single Motor.....	39-40
Brush Head Stand.....	41
Brush Frame Labels.....	42
Quick Attach.....	43

21059MH-XXXX	5 FT	QC, 32", Single	18 ci, Hydraulic Angle Broom
21059MM-XXXX	5 FT	QC, 32", Single	18 ci, Manual Angle Broom
21060MH-XXXX	5 FT	QC, 32", Single	24 ci, Hydraulic Angle Broom
21060MM-XXXX	5 FT	QC, 32", Single	24 ci, Manual Angle Broom
21061MH-XXXX	5 FT	QC, 32", Dual	18 ci, Hydraulic Angle Broom
21061MM-XXXX	5 FT	QC, 32", Dual	18 ci, Manual Angle Broom
21071MH-XXXX	6 FT	QC, 32", Single	18 ci, Hydraulic Angle Broom
21071MM-XXXX	6 FT	QC, 32", Single	18 ci, Manual Angle Broom
21072MH-XXXX	6 FT	QC, 32", Single	24 ci, Hydraulic Angle Broom
21072MM-XXXX	6 FT	QC, 32", Single	24 ci, Manual Angle Broom
21073MH-XXXX	6 FT	QC, 32", Dual	18 ci, Hydraulic Angle Broom
21073MM-XXXX	6 FT	QC, 32", Dual	18 ci, Manual Angle Broom
21083MH-XXXX	7 FT	QC, 32", Single	18 ci, Hydraulic Angle Broom
21083MM-XXXX	7 FT	QC, 32", Single	18 ci, Manual Angle Broom
21084MH-XXXX	7 FT	QC, 32", Single	24 ci, Hydraulic Angle Broom
21084MM-XXXX	7 FT	QC, 32", Single	24 ci, Manual Angle Broom
21085MH-XXXX	7 FT	QC, 32", Dual	18 ci, Hydraulic Angle Broom
21085MM-XXXX	7 FT	QC, 32", Dual	18 ci, Manual Angle Broom
21096MH-XXXX	8 FT	QC, 32", Single	24 ci, Hydraulic Angle Broom
21096MM-XXXX	8 FT	QC, 32", Single	24 ci, Manual Angle Broom
21097MH-XXXX	8 FT	QC, 32", Dual	18 ci, Hydraulic Angle Broom
21097MM-XXXX	8 FT	QC, 32", Dual	18 ci, Manual Angle Broom

PARTS SECTION  
BRUSH HEAD FRAME

## Brush Head Frames

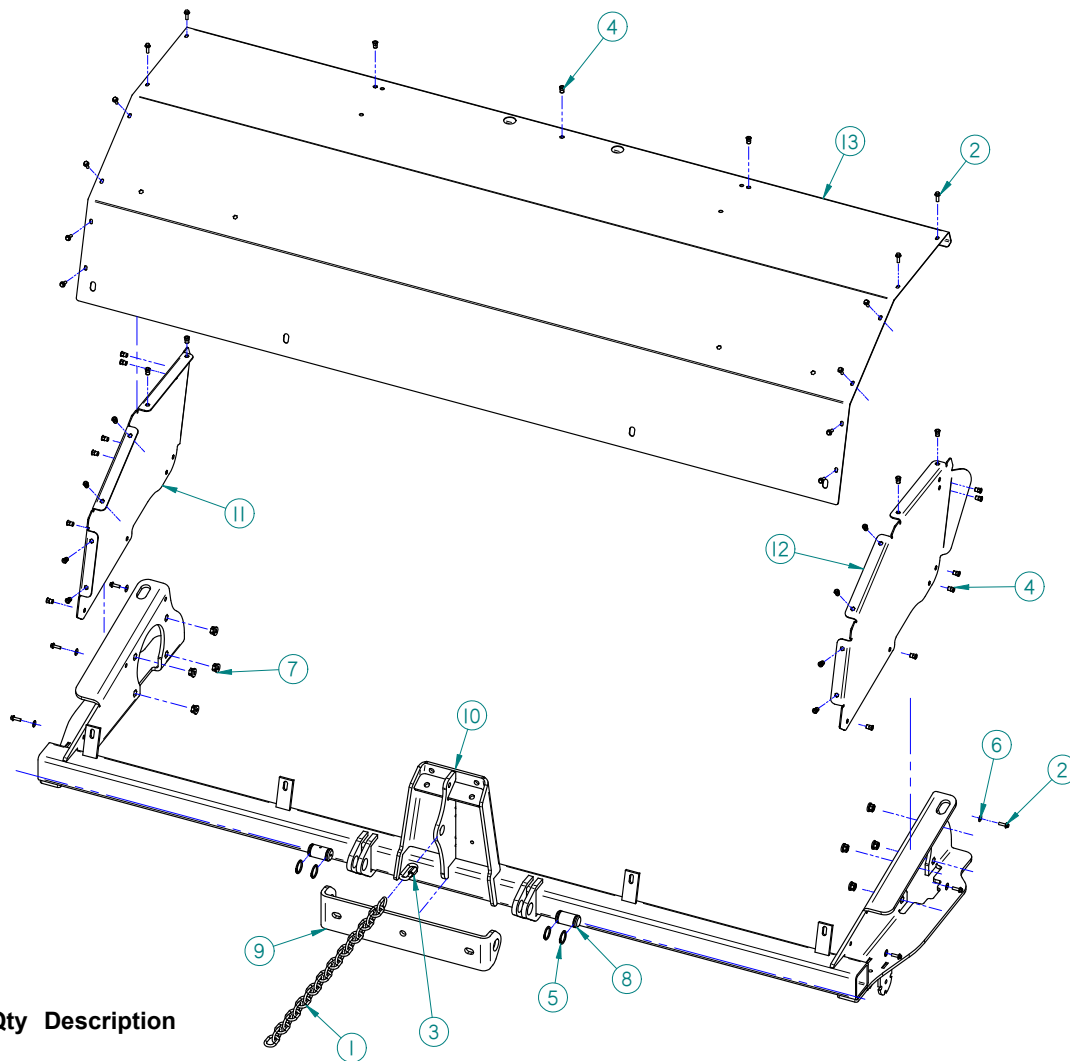

Item	Part	Qty	Description
1.	07-0249	1	Chain, 1/4 x 22
2.	07-2952	18	Screw, HFH, CL10.9, M6-1 x 20
3.	07-3311	1	Link, Quick, 5/16
4.	07-3617	27	Nut, Insert, M6 x 1
5.	07-3842	4	Ring, Snap
6.	07-4927	6	Washer, Fender, CL8.8, M6
7.	07-6056	8	Nut, Flange, M10-1.5
8.	13-10004	2	Pin, Pivot, Left Arm, QA
9.	13-12617	1	Plate, Mounting, Brush Head, Pivot
10.	13-16417	1	Weld, Brush Frame, 4 Ft
	13-13278	1	Weld, Brush Frame, 5 Ft
	13-13279	1	Weld, Brush Frame, 6 Ft
	13-12857	1	Weld, Brush Frame, 7 Ft
	13-13280	1	Weld, Brush Frame, 8 Ft
	13-13594	1	Weld, Brush Frame, 9 Ft
11.	13-13047	1	Sheet, Hood, Side, Left
12.	13-13048	1	Sheet, Hood, Side, Right
13.	13-16416	1	Sheet, Hood, 4 Ft
	13-13281	1	Sheet, Hood, 5 Ft
	13-13282	1	Sheet, Hood, 6 Ft
	13-13049	1	Sheet, Hood, 7 Ft
	13-13283	1	Sheet, Hood, 8 Ft
	13-13595	1	Sheet, Hood, 9 Ft



## Core Assemblies

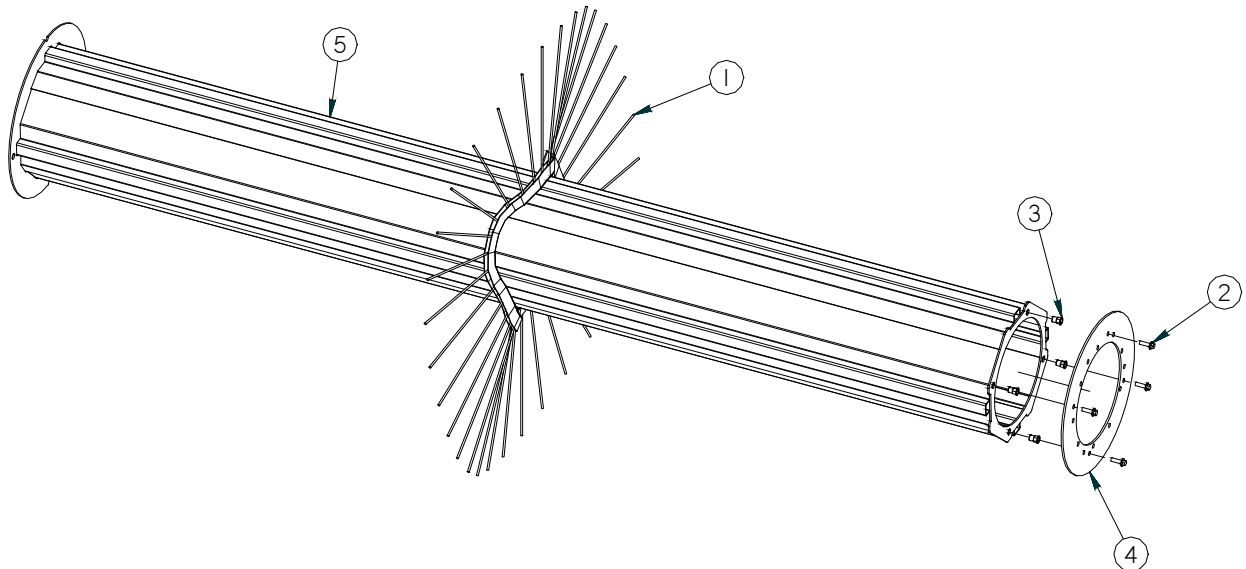

### Item Part Qty Description

1.	01-1201	1	Section, Set, 32, 10, Mixed, Convolute ( 4 Ft )
	01-1085	1	Section, Set, 32, 10, Mixed, Convolute ( 5 Ft )
	01-0930	1	Section, Set, 32, 10, Mixed, Convolute ( 6 Ft )
	01-0931	1	Section, Set, 32, 10, Mixed, Convolute ( 7 Ft )
	01-0933	1	Section, Set, 32, 10, Mixed, Convolute ( 8 Ft )
	01-1148	1	Section, Set, 32, 10, Mixed, Convolute ( 9 Ft )
	01-1200	1	Section, Set, 32, Poly, Convolute ( 4 Ft )
	01-0272C	1	Section, Set, 32, Poly, Convolute ( 5 Ft )
	01-0020C	1	Section, Set, 32, Poly, Convolute ( 6 Ft )
	01-0079C	1	Section, Set, 32, Poly, Convolute ( 7 Ft )
	01-0080C	1	Section, Set, 32, Poly, Convolute ( 8 Ft )
	01-0530C	1	Section, Set, 32, Poly, Convolute ( 9 Ft )
2.	07-2952	4	Screw, HFH, CL10.9, M6-11 x 20
3.	07-3617	4	Nut, Insert, M6 x 1
4.	13-13166	1	Plate, Ring, Core, End, QC
5.	13-16418	1	Weld, Core, 4 Ft, Hex Drive
	13-13284	1	Weld, Core, 5 Ft, Hex Drive
	13-13285	1	Weld, Core, 6 Ft, Hex Drive
	13-12899	1	Weld, Core, 7 Ft, Hex Drive
	13-13286	1	Weld, Core, 8 Ft, Hex Drive
	13-13596	1	Weld, Core, 9 Ft, Hex Drive

PARTS SECTION  
SHAFT ASSEMBLY

## Shaft Assembly

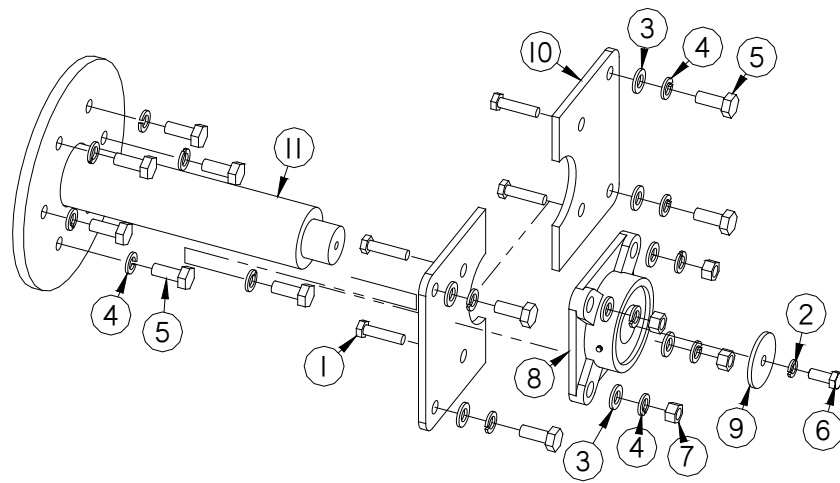
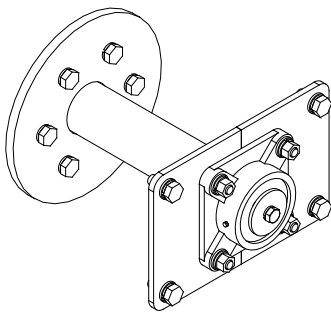
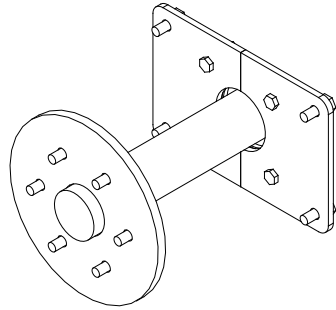

**Item Part Qty Description**

1.	07-2495	4	Screw, HHC, CL8.8, M10-1.5 x 35mm
2.	07-3738	1	Washer, Lock, Split, Medium, M8
3.	07-3745	8	Washer, Flat, CL8.8, M10
4.	07-3747	14	Washer, Lock, Split, Medium, M10
5.	07-3748	10	Screw, HHC, CL10.9, M10-1.5 x 25mm
6.	07-3777	1	Screw, HHC, CL10.9, M8-1.25 x 20mm
7.	07-4514	4	Nut, Hex, CL10, M10-1.5
8.	08-0067	1	Bearing, 1 1/4, 4 Bolt
9.	13-11903	1	Washer, .34 x 1.8 x 10Ga
10.	13-12941	2	Plate, Shaft, Brush Frame, Mounting
11.	13-12974	1	Weld, Shaft, Hex Drive

## Motor Bucket Assemblies

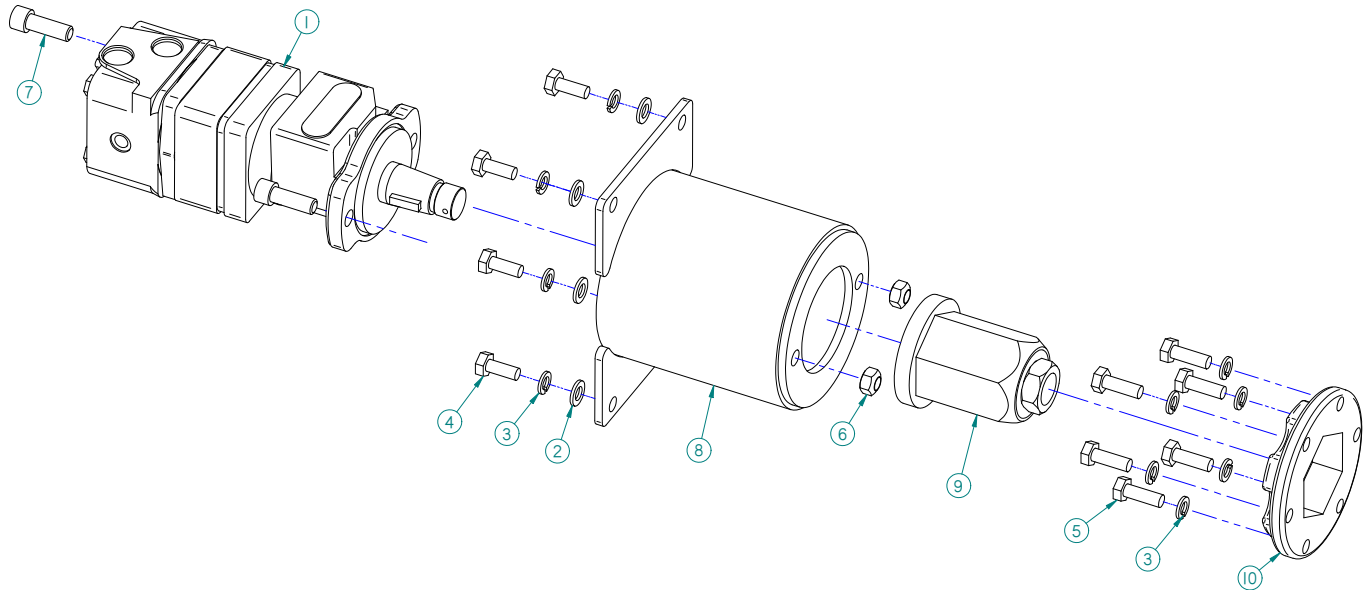

Item	Part	Qty	Description
------	------	-----	-------------

1.	03-4682	1	Motor, Hydraulic, White, 17.9 Cu In, with Check Valve, Right (Dual Motor)
	03-4634	1	Motor, Hydraulic, White, 17.9 Cu In, with Check Valve, Left (Single or Dual Motor)
	03-4425	1	Motor, Hydraulic, White, 24.9 Cu In, with Check Valve, Left (Single Motor)
2.	07-3745	4	Washer, Flat, CL8.8, M10
3.	07-3747	10	Washer, Lock, Split, Medium, M10
4.	07-3748	4	Screw, HHC, CL10.9, M10-1.5 x 25mm
5.	07-3749	6	Screw, HHC, CL10.9, M10-1.5 x 30mm
6.	07-4610	2	Nut, Hex, Lock, CL10.9, M12-1.75
7.	07-6178	2	Screw, Socket Head, M12-1.75 x 35mm
8.	13-12946	1	Weld, Motor Bucket
9.	13-15206	1	Hub, Hex, 2 1/2 x 1 1/4, Tapered Bore x 3.75
10.	13-16225	1	Plate, Receiver, Hex, 2.50

Replacement Parts for 03-4682, 03-4634, and 03-4425 Motors :

03-3081 Seal Kit  
 07-4657 Key  
 07-4568 Shaft Nut  
 03-5543 Shaft Motor

PARTS SECTION  
HYDRAULIC ASSEMBLIES

## Hydraulic Assemblies - Dual Motor

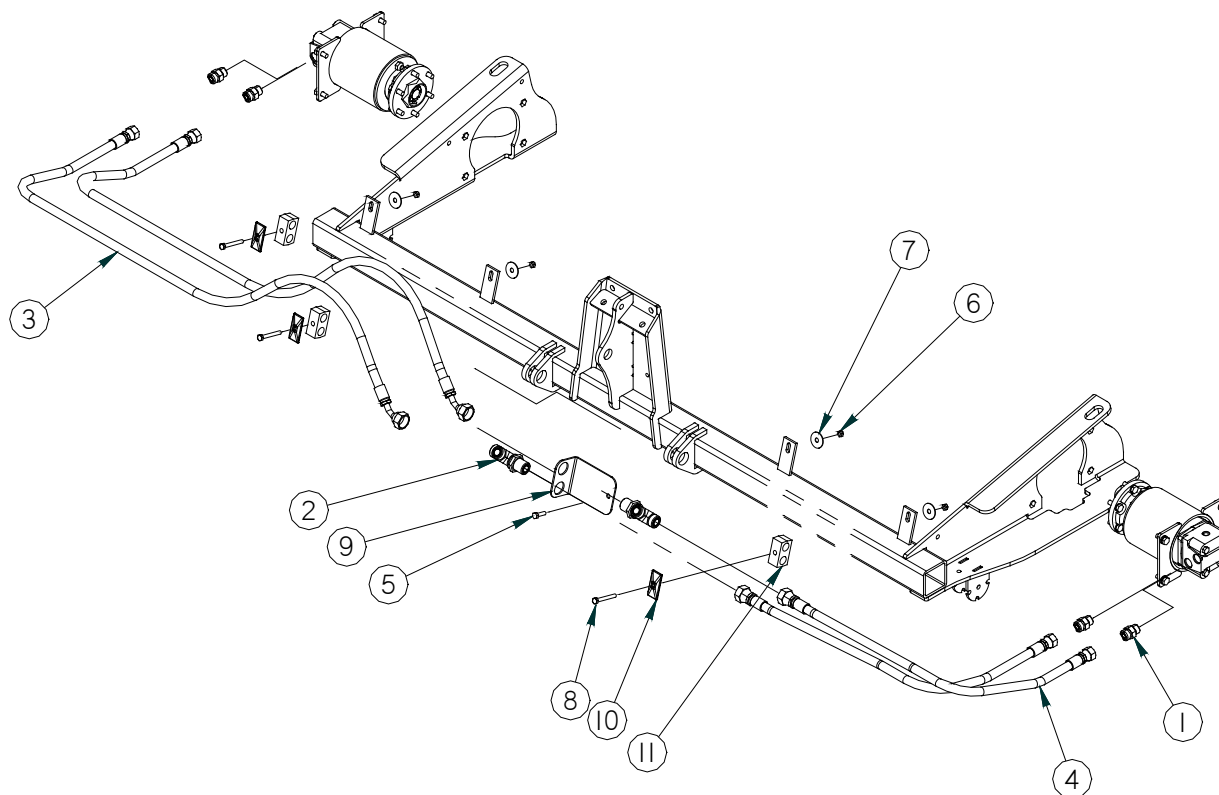

Item	Part	Qty	Description
1.	03-1939	4	Fitting, 10MB-10MF
2.	03-5160	2	Tee, 12MF-12MF-12MF, Bulkhead
3.	03-5161	2	Hose, .50 x 68, 10FF-12FF45, 3.5K (5 ft)
	03-5162	2	Hose, .50 x 75, 10FF-12FF45, 3.5K (6 ft)
	03-5163	2	Hose, .50 x 80, 10FF-12FF45, 3.5K (7 ft)
	03-5164	2	Hose, .50 x 86, 10FF-12FF45, 3.5K (8 ft)
4.	03-5165	2	Hose, .50 x 32, 10FF-12FF, 3.5K (5 ft)
	03-5166	2	Hose, .50 x 38, 10FF-12FF, 3.5K (6 ft)
	03-5167	2	Hose, .50 x 44, 10FF-12FF, 3.5K (7 ft)
	03-5168	2	Hose, .50 x 50, 10FF-12FF, 3.5K (8 ft)
5.	07-3740	1	Screw, HHC, CL10.9, M8-1.25 x 30mm
6.	07-4604	4	Nut, Hex, Lock, CL10.9, M8-1.25
7.	07-4942	4	Washer, Fender, 1 1/2 x 5/16
8.	07-5287	3	Screw, HHC, CL10.9, M8-1.25 x 65mm
9.	13-15094	1	Bracket, Mounting, Bulkhead Tees
10.	RHW8614	3	Cover Plate
11.	RHW8616	3	Hose Cradle

## Hydraulic Assemblies - Dual Motor Manual Angle

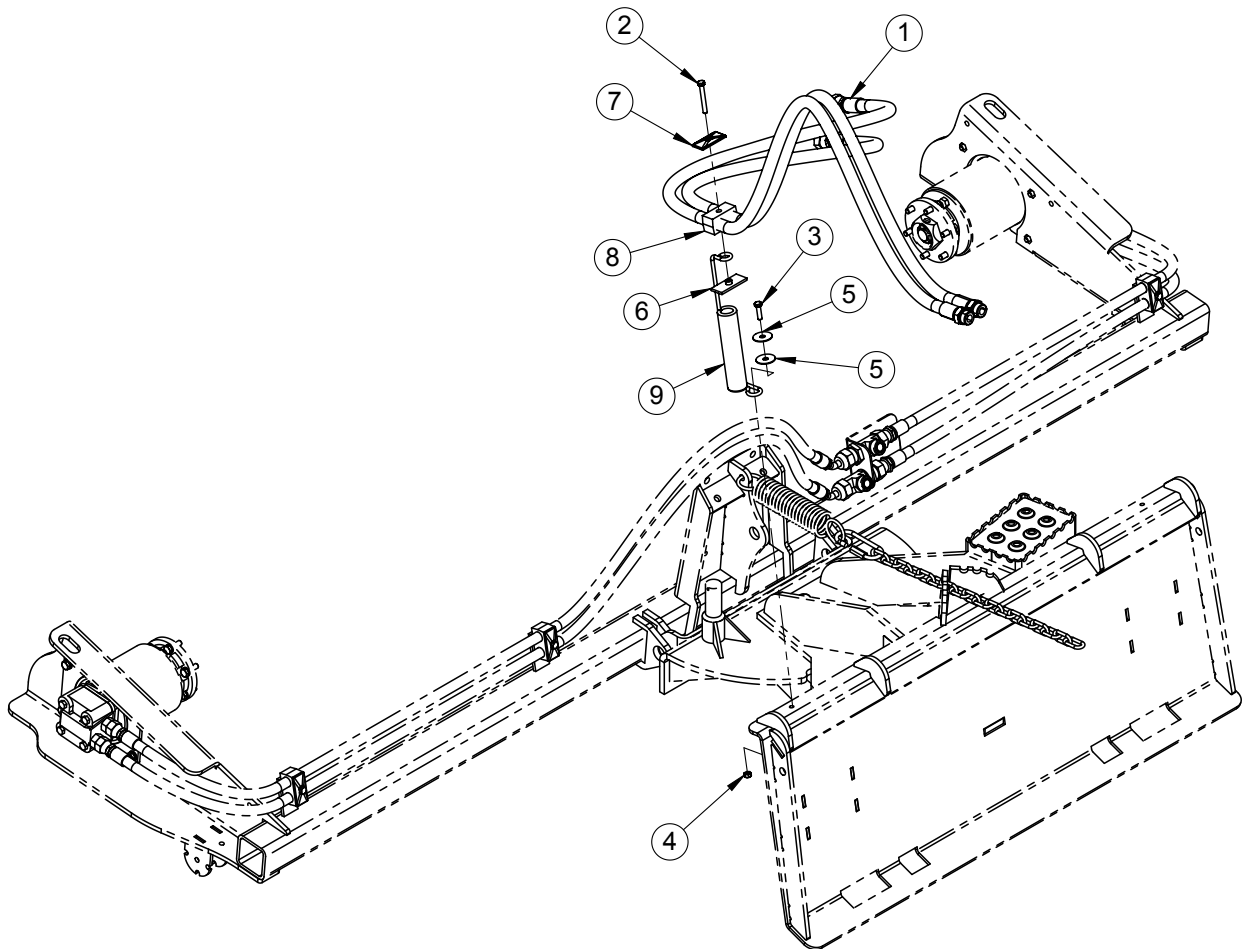

Item	Part	Qty	Description
1.	03-5169	2	Hose, .63 x 140, 12FF-12MB, 2.75K, HS
2.	07-1784	1	Screw, HHC, Gr8, 5/16-18 x 2 1/2
3.	07-3740	1	Screw, HHC, CL10.9, M8-1.25 x 30mm
4.	07-4604	1	Nut, Hex, Lock, CL10.9, M8-1.25
5.	07-4942	2	Washer, Fender, 1 1/2 x 5/16
6.	RHW8613	1	Weld, Plate
7.	RHW8614	1	Cover, Plate
8.	RHW8616	1	Hose, Cradle
9.	RHW8618	1	Hose, Spring

PARTS SECTION  
HYDRAULIC ASSEMBLIES

## Hydraulic Assemblies - Dual Motor Hydraulic Angle

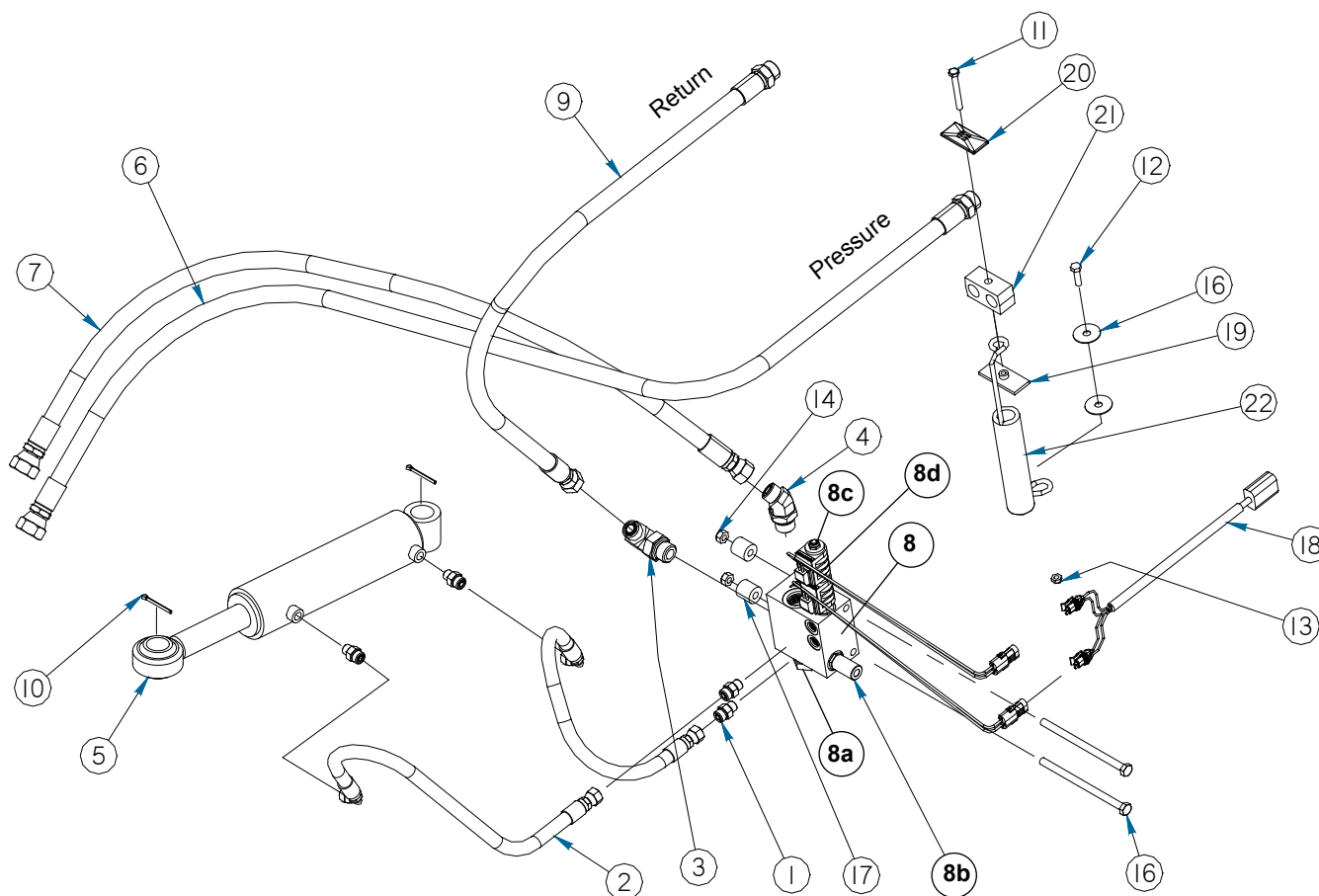

Item	Part	Qty	Description
1.	03-2291	4	Fitting, 6MF-6MB, 6F5OLO-S
2.	03-2352	2	Hose, .38 x 32, 6FF-6FF90, 4.75K
3.	03-2396	1	Elbow, 90, 10MF-12MB
4.	03-4700	1	Elbow, 45, 10MF-12MB
5.	03-4887	1	Cylinder, 2.50 x 1.38 x 7.50, 3.5K
6.	03-5169	1	Hose, .63 x 140, 12FF-12MB, 2.75K, HS
7.	03-5173	1	Hose, .63 x 60, 10FF-12FF, 3.625K
8.	03-5215	1	Manifold, Swing, 12 Volt
	03-5280	1	Manifold, Swing, 24 Volt
8a	07-7150	1	Valve, Cartridge, Pressure Comp
8b	07-7151	1	Valve, Cartridge, Relief
8c	07-7152	1	Valve, Cartridge, Directional
8d	07-7153	2	Coil, 12 Volt
	07-7134	2	Coil, 24 Volt
9.	03-5385	1	Hose, .63 x 80, 10FF-10MB, 3K, HS
10.	07-0206	2	Pin, Cotter, Gr2, 3/16 x 2
11.	07-1784	1	Screw, HHC, Gr8, 5/16-18 x 2 1/2
12.	07-3740	1	Screw, HHC, CL10.9, M8-1.25 x 30mm
13.	07-4604	1	Nut, Hex, Lock, CL10.9, M8-1.25
14.	07-4622	2	Nut, Hex, Lock, CL10.9, M10-1.5
15.	07-4942	2	Washer, Fender, 1 1/2 x 5/16
16.	07-7131	2	Screw, HHC, CL10.9, M10-1.5 x 160mm
17.	13-11248	2	Bushing, 1 x .406 x 1
18.	LAF9441	1	Wire, Assembly, 9 ft
19.	RHW8613	1	Weld, Plate
20.	RHW8614	1	Cover, Plate
21.	RHW8616	1	Hose, Cradle
22.	RHW8618	1	Hose, Spring

Replacement Part for 03-4887 Cylinder :

03-4888 Seal Kit

03-5035 Cylinder Rod

## Hydraulic Assembly - Single Motor Manual Angle

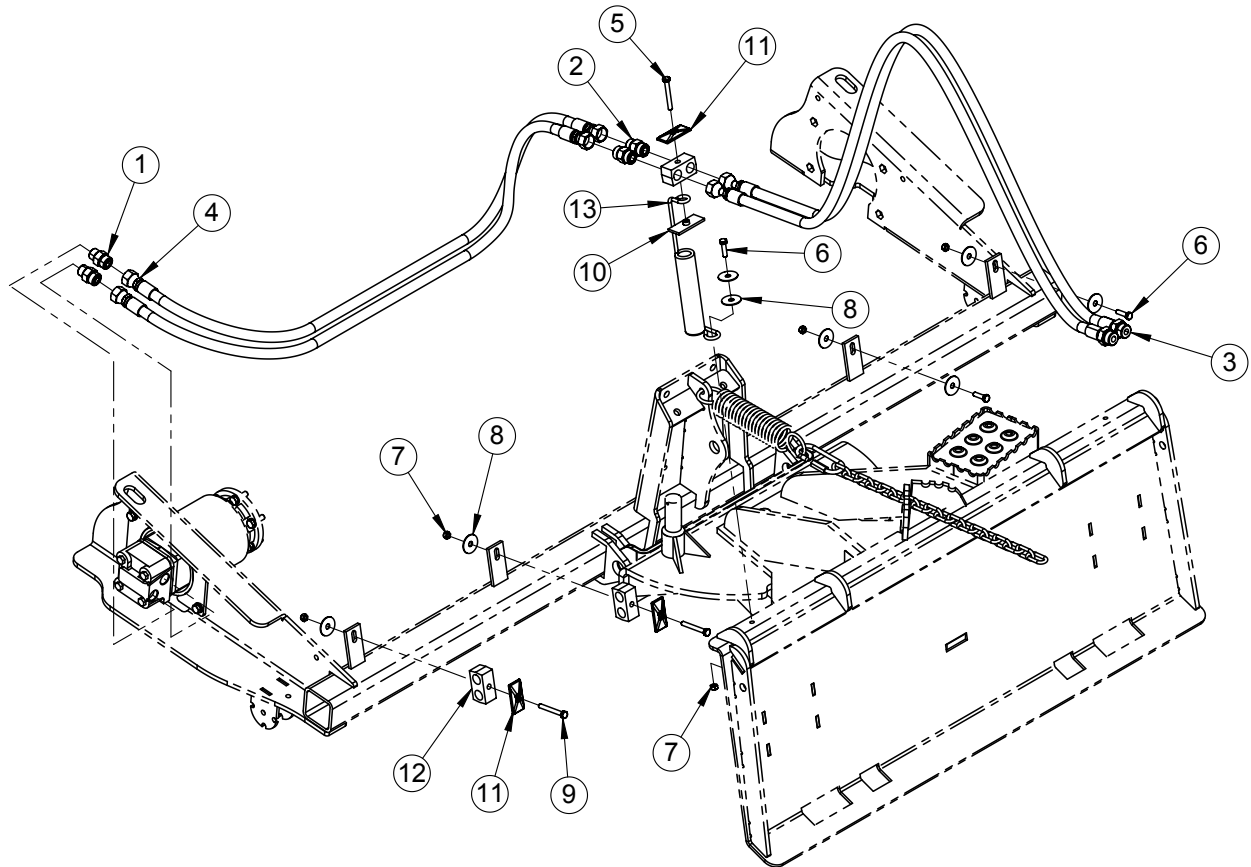

### Item Part Qty Description

1.	03-1939	2	Fitting, 10MB-10MF
2.	03-4804	2	Fitting, 10MF-10MF, UN
3.	03-5153	2	Hose, .50 x 80, 10FF-12MB, 3.5K, HS
4.	03-5154	2	Hose, .50 x 112, 10FF- 10FF, 3.5K
5.	07-1784	1	Screw, HHC, 5/16-18 x 2 1/2
6.	07-3740	3	Screw, HHC, CL10.9, M8-1.25 x 30mm
7.	07-4604	5	Nut, Hex, Lock, CL10.9, M8-1.25
8.	07-4942	8	Washer, Fender, 1 1/2 x 5/16
9.	07-5287	2	Screw, HHC, CL10.9, M8-1.25 x 65mm
10.	RHW8613	1	Weld, Plate
11.	RHW8614	3	Cover, Plate
12.	RHW8616	3	Hose, Cradle
13.	RHW8618	1	Hose, Spring

PARTS SECTION  
HYDRAULIC ASSEMBLIES

## Hydraulic Assembly - Single Motor Hydraulic Angle

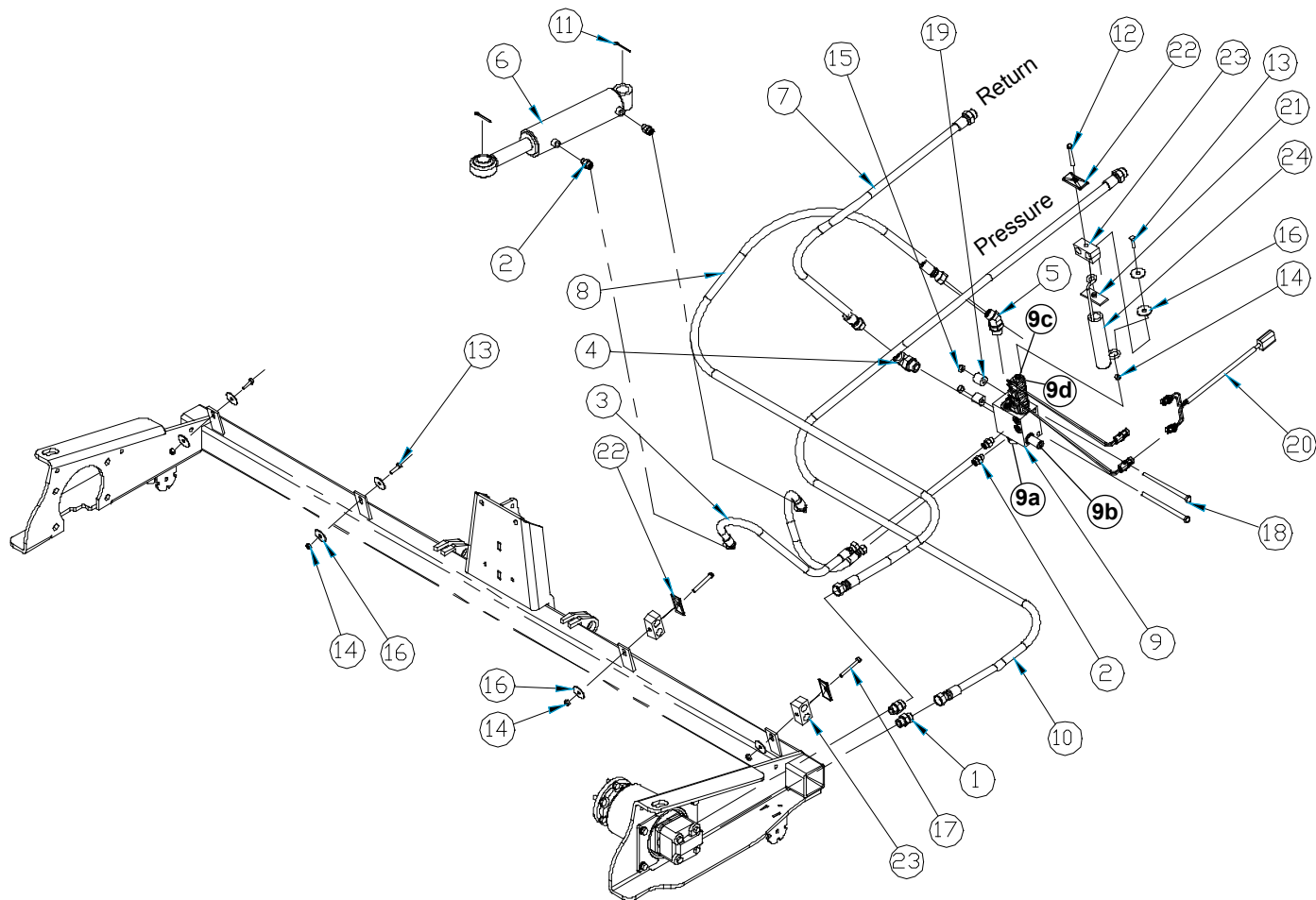

Item	Part	Qty	Description
1.	03-1939	2	Fitting, 10MB-10MF
2.	03-2291	4	Fitting, 6MF-6MB, 6F5OLO-S
3.	03-2352	2	Hose, .38 x 32, 6FF-6FF90, 4.75K
4.	03-2396	1	Elbow, 90, 10MF-12MB
5.	03-4700	1	Elbow, 45, 10MF-12MB
6.	03-4887	1	Cylinder, 2.50 x 1.38 x 7.50, 3.5K Ball
7.	03-5153	1	Hose, .50 x 80, 10FF-12MB, 3.5K, HS
8.	03-5154	1	Hose, .50 x 112, 10FF-10FF, 3.5K
9.	03-5215	1	Manifold, Swing, 12 Volt
	03-5280	1	Manifold, Swing, 24 Volt
9a	07-7150	1	Valve, Cartridge, Pressure, Comp
9b	07-7151	1	Valve, Cartridge, Relief
9c	07-7152	1	Valve, Cartridge, Directional
9d	07-7153	2	Coil, 12 Volt
	07-7134	2	Coil, 24 Volt
10.	03-5383	1	Hose, .50 x 195, 10FF-12MB, 3K, HS
11.	07-0206	2	Pin, Cotter, Gr2, 3/16 x 2
12.	07-1784	1	Screw, HHC, Gr8, 5/16-18 x 2 1/2
13.	07-3740	3	Screw, HHC, CL10.9, M8-1.25 x 30mm
14.	07-4604	5	Nut, Hex, Lock, CL10.9, M8-1.25
15.	07-4622	2	Nut, Hex, Lock, CL10.9, M10-1.5
16.	07-4942	8	Washer, Fender, 1 1/2 x 5/16
17.	07-5287	2	Screw, HHC, CL10.9, M8-1.25 x 65mm
18.	07-7131	2	Screw, HHC, CL10.9, M10-1.5 x 160mm
19.	13-11248	2	Bushing, 1 x .406 x 1
20.	LAF9441	1	Wire, Assembly, 9ft
21.	RHW8613	1	Weld, Plate
22.	RHW8614	3	Cover, Plate
23.	RHW9616	3	Hose, Cradle
24.	RHW9618	1	Hose, Spring

Replacement Part for 03-4887 Cylinder :

03-4888 Seal Kit  
03-5035 Cylinder Rod



## Brush Head Stands

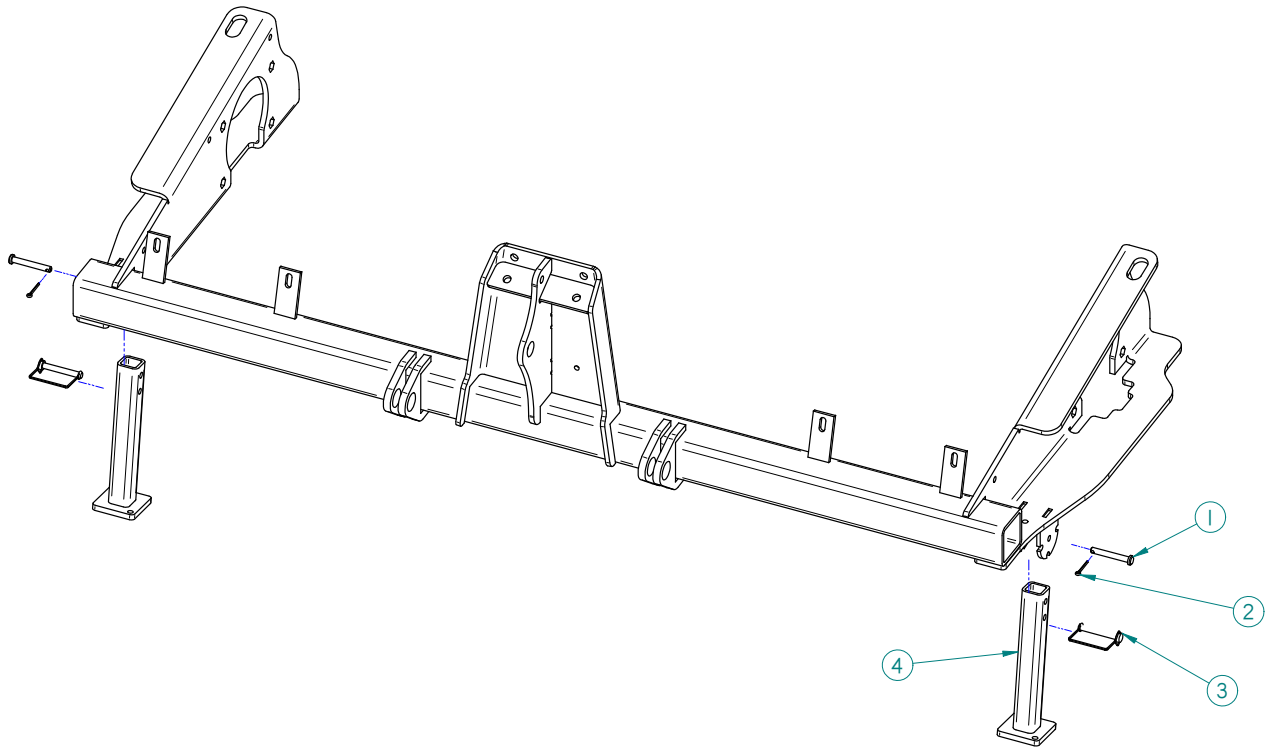

Item	Part	Qty	Description
------	------	-----	-------------

1.	07-0260	2	Pin, Clevis, Gr2, 3/8 x 2 3/4
2.	07-0699	2	Pin, Cotter, Gr2, 1/8 x 1 1/4
3.	07-4748	2	Pin, Lock, 3/8 x 2, Grip, Square, 2.50AL
4.	13-13226	2	Weld, Stand, Brush Head

PARTS SECTION  
BRUSH HEAD LABELS

## Brush Head Labels

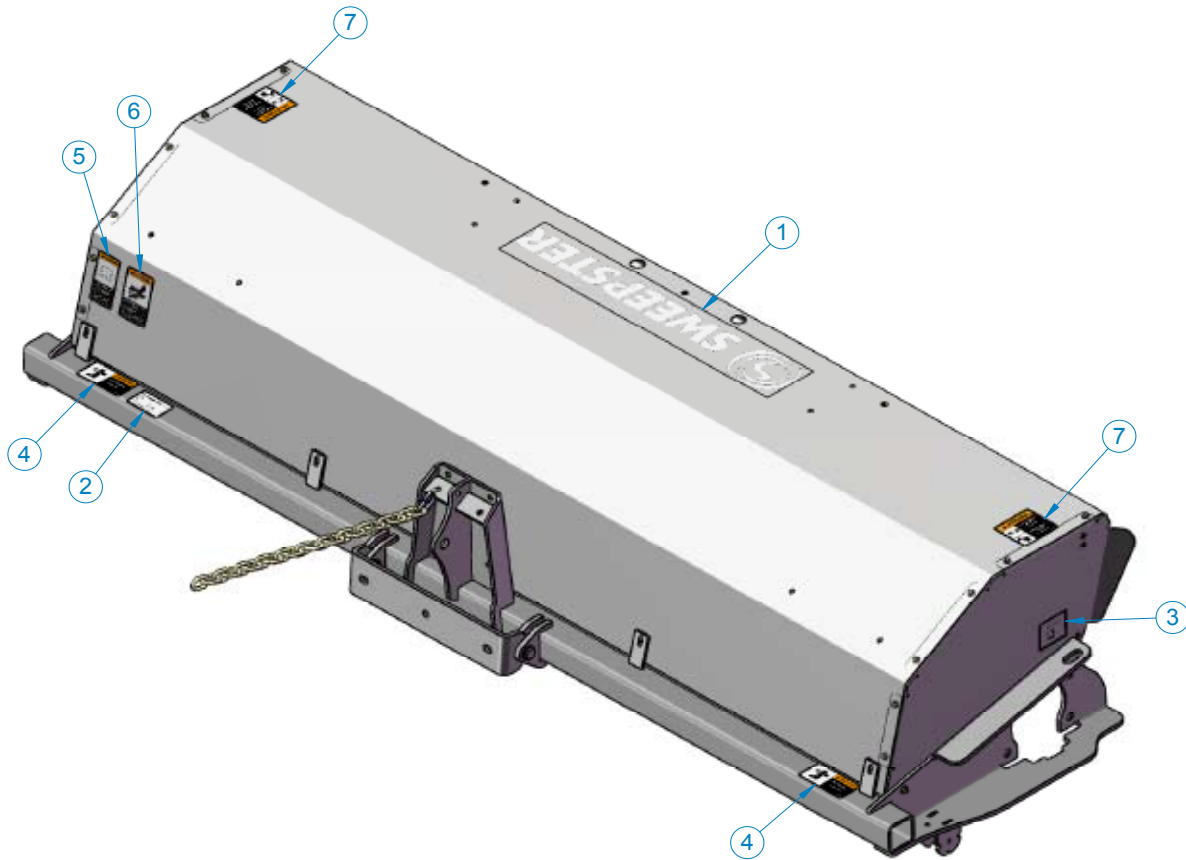

Item	Part	Qty	Description
------	------	-----	-------------

1.	50-0252	1	Label, Logo, Large, White
2.	50-0634	1	Label, Serial Number
3.	50-0643	2	Label, Tie Down Point
4.	50-0721	2	Label, Warning, Crush Hazard
5.	50-0722	1	Label, Warning, Misuse Hazard
6.	50-0724	1	Label, Warning, High Pressure Fluid Hazard
7.	50-0726	2	Label, Warning, Flying Objects & Entanglement

## Quick Attach

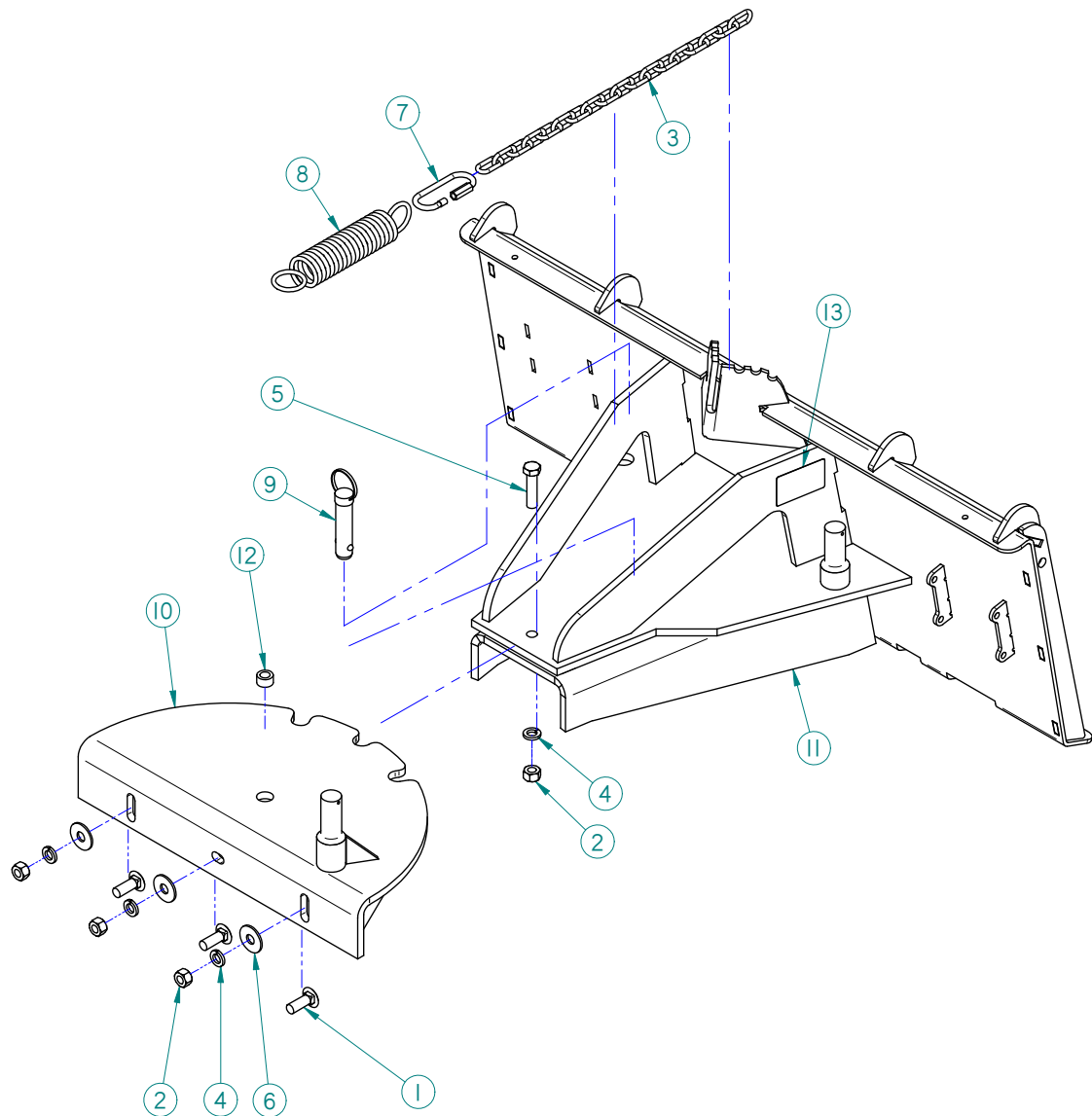

### Item Part Qty Description

1.	07-0119	3	Bolt, Carriage, Gr5, 5/8-11 x 1 3/4
2.	07-1294	4	Nut, Hex, Gr8, 5/8-11
3.	07-1558	1	Chain, 1/4, 18 Links
4.	07-1872	4	Washer, Lock, Split, Medium, 5/8
5.	07-2855	1	Screw, HHC, Gr8, 5/8-11 x 2 1/2
6.	07-3120	3	Washer, Flat, Gr8, 5/8
7.	07-5294	1	Link, Quick, 5/16, Wide Jaw
8.	07-6451	1	Spring, Tension, 325#/in
9.	07-6903	1	Pin, Quick Release, 1 x 3
10.	11-9080	1	Weld, Swing, Plate
11.		1	Weld, Frame, Mounting (Contact Sweepster with seial number and model number of unit for correct part)
12.	13-4657	1	Bushing, 1 x 5/8 x .562
13.	50-0635	1	Label, Plate, Part Number/Date

# Notes

---

---

# Options Section

---

## QC Series Angle Brooms

---

### Table of Contents

<b>Options .....</b>	<b>46-53</b>
Hood Kits.....	46-47
Hydraulic Angle .....	48
Dust Suppression Systems .....	49-50
Sight Indicator Kits .....	51
Manual to Hydraulic Conversion Kits .....	52-53

OPTION SECTION  
HOOD KITS

# 180° Hood Kits with Drape

**Factory Installed**

- 28-9787 5 Ft
- 28-9788 6 Ft
- 28-9789 7 Ft
- 28-9790 8 Ft
- 28-9797 9 Ft

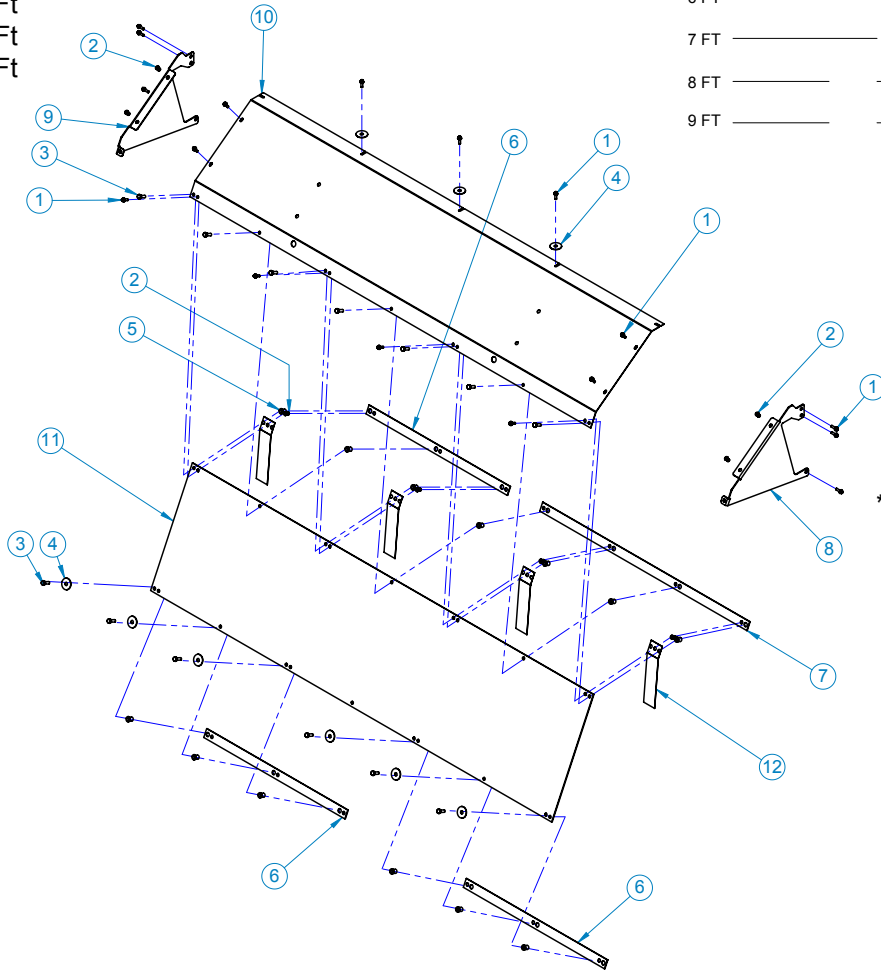

RETAINER STRAP COMBINATIONS

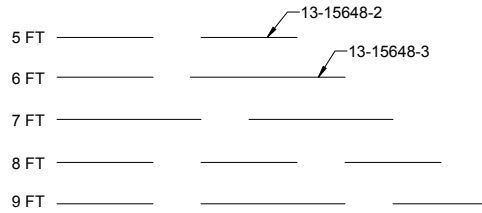

\*See chart for correct combination.

Item	Part	Qty	Description	Item	Part	Qty	Description
1.	07-3522	17	Screw, HFH, CL10.9, M6-1 x 20	7.	13-15648-3	0	Plate, Retainer, Flap, 3 Ft (5ft)
2.	07-3617	8	Nut, Insert, Hex, M6 x 1	13-15648-3	1	Plate, Retainer, Flap, 3 Ft (6ft)	
3.	07-3739	12	Screw, HHC, CL10.9, M8-1.25 x 25mm (5ft)	13-15648-3	2	Plate, Retainer, Flap, 3 Ft (7ft)	
	07-3739	13	Screw, HHC, CL10.9, M8-1.25 x 25mm (6ft)	13-15648-3	0	Plate, Retainer, Flap, 3 Ft (8ft)	
	07-3739	14	Screw, HHC, CL10.9, M8-1.25 x 25mm (7ft)	13-15648-3	1	Plate, Retainer, Flap, 3 Ft (9ft)	
	07-3739	15	Screw, HHC, CL10.9, M8-1.25 x 25mm (8ft)	8.	13-16045	1	Sheet, Hood, Extension, Side, Left
	07-3739	16	Screw, HHC, CL10.9, M8-1.25 x 25mm (9ft)	9.	13-16046	1	Sheet, Hood, Extension, Side, Right
4.	07-4942	9	Washer, Fender, 5/16 x 1	10.	13-16047-5	1	Sheet, Hood, Extension, 5 Ft
5.	07-7115	12	Nut, Insert, M8-1.25 (5ft)	13-16047-6	1	Sheet, Hood, Extension, 6 Ft	
	07-7115	13	Nut, Insert, M8-1.25 (6ft)	13-16047-7	1	Sheet, Hood, Extension, 7 Ft	
	07-7115	14	Nut, Insert, M8-1.25 (7ft)	13-16047-8	1	Sheet, Hood, Extension, 8 Ft	
	07-7115	15	Nut, Insert, M8-1.25 (8ft)	13-16047-9	1	Sheet, Hood, Extension, 9 FT	
	07-7115	16	Nut, Insert, M8-1.25 (9ft)	11.	13-16199-5	1	Flap, Deflector, 180° Hood 5 Ft
6.	13-15648-2	4	Plate, Retainer, Flap, 2 Ft (5ft)	13-16199-6	1	Flap, Deflector, 180° Hood 6 Ft	
	13-15648-2	3	Plate, Retainer, Flap, 2 Ft (6ft)	13-16199-7	1	Flap, Deflector, 180° Hood 7 Ft	
	13-15648-2	2	Plate, Retainer, Flap, 2 Ft (7ft)	13-16199-8	1	Flap, Deflector, 180° Hood 8 Ft	
	13-15648-2	5	Plate, Retainer, Flap, 2 Ft (8ft)	13-16199-9	1	Flap, Deflector, 180° Hood 9 Ft	
	13-15648-2	4	Plate, Retainer, Flap, 2 Ft (9ft)	12.	13-16200	4	Plate, Spring, 180°, Hood, Flap

# 180° Hood Kits

<u>Field Installed</u>		<u>Factory Installed</u>	
28-9722	5 Ft	28-9783	5 Ft
28-9723	6 Ft	28-9784	6 Ft
28-9724	7 Ft	28-9785	7 Ft
28-9725	8 Ft	28-9786	8 Ft
28-9748	9 Ft	28-9796	9 Ft

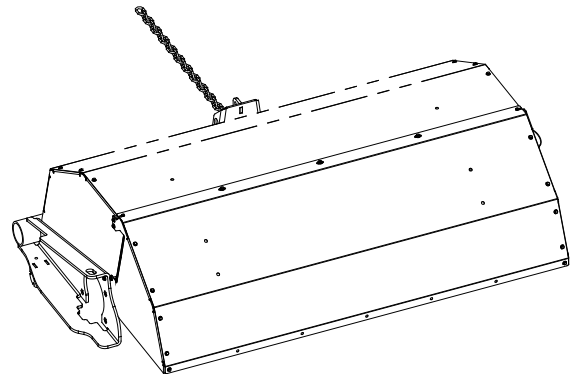
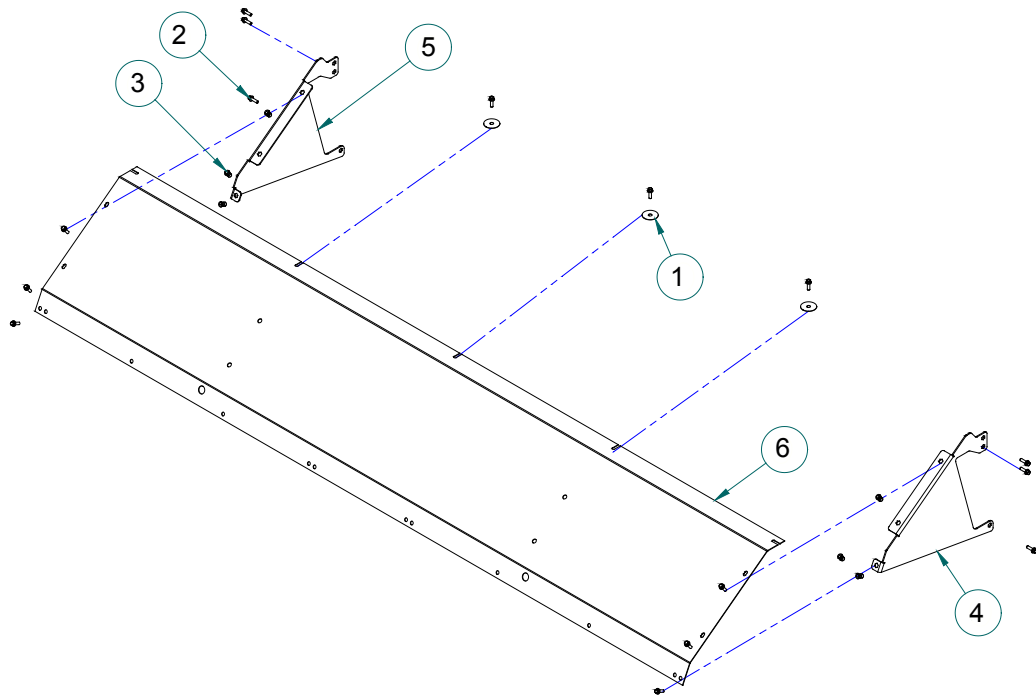

Item	Part	Qty	Description
1.	07-4942	3	Washer, Fender, 5/16 x 1 1/2
2.	07-3522	15	Screw, HFH, CL10.9, M6-1 x 20
3.	07-3617	6	Nut, Insert, Hex, M6 x 1
4.	13-16045	1	Sheet, Hood, Extension, Side, Left
5.	13-16046	1	Sheet, Hood, Extension, Side, Right
6.	13-16047-5	1	Sheet, Hood, Extension 5 Ft
	13-16047-6	1	Sheet, Hood, Extension 6 Ft
	13-16047-7	1	Sheet, Hood, Extension 7 Ft
	13-16047-8	1	Sheet, Hood, Extension 8 Ft
	13-16047-9	1	Sheet, Hood, Extension 9 Ft

OPTION SECTION  
HYDRAULIC ANGLE

## Hydraulic Angle - Field Installed 11-4297 & 11-4298

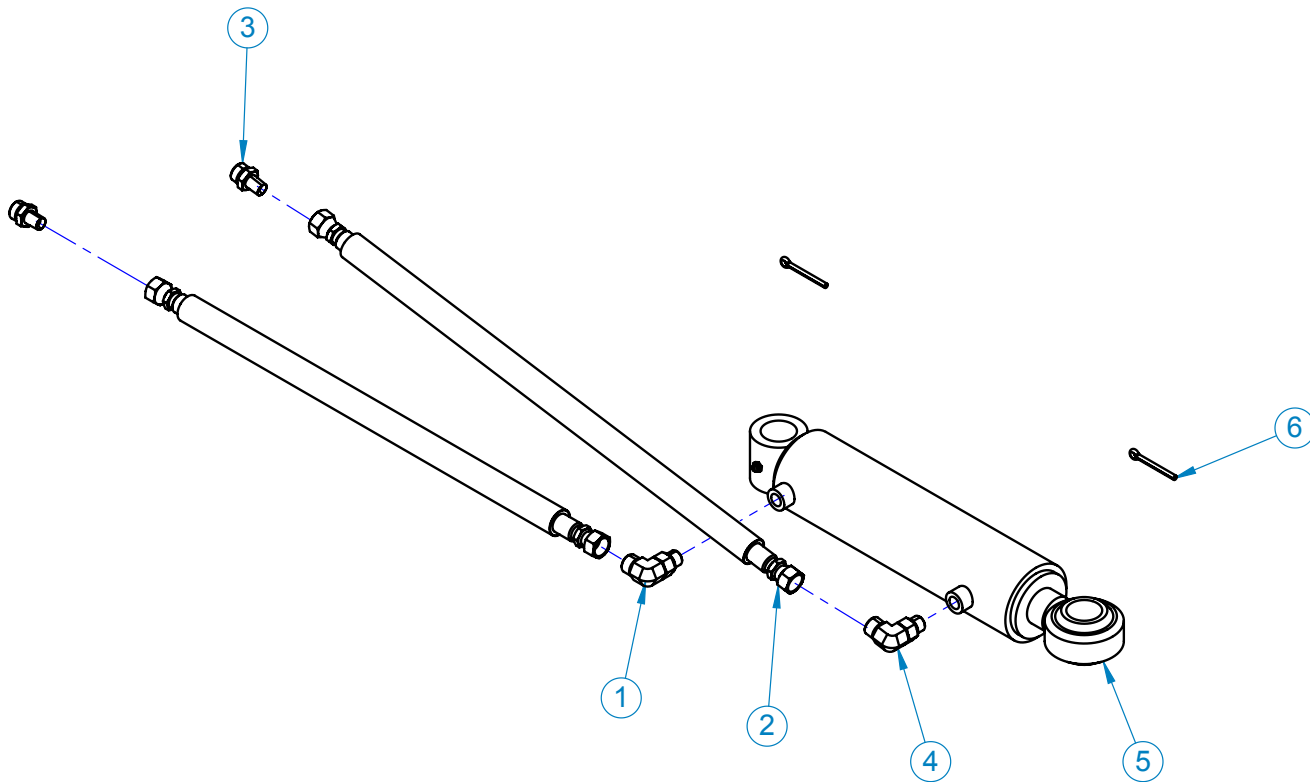

**Item Part Qty Description**

1.	03-2092	1	Elbow, 90, 6MF-6MB, 6C50L0-S
2.	03-2155	2	Hose, .25 x 72, 6FF-6FF, 3.25K (11-4298)
	03-2158	2	Hose, .25 x 144, 6FF-6FF, 3.25K (11-4297)
3.	03-2159	2	Fitting, 6MF-4MP, 6FL0-S
4.	03-2345	1	Fitting, Orifice, .078, Elbow, 90°, HP, 9/16MOR, 3/8MFS
5.	03-4887	1	Cylinder, 2.50 x 1.38 x 7.50, 3.5K Ball-Cross Tube
6.	07-0206	2	Pin, Cotter, 3/16 x 2

Replacement Part for 03-4887 Cylinder :

03-4888 Seal Kit

03-5035 Cylinder Rod



# Dust Suppression System

## Direct Nozzle Mount

**Field Installed**

28-9919 12 Volt  
28-10116 24 Volt

**Factory Installed**

28-10114 12 Volt  
28-10115 24 Volt

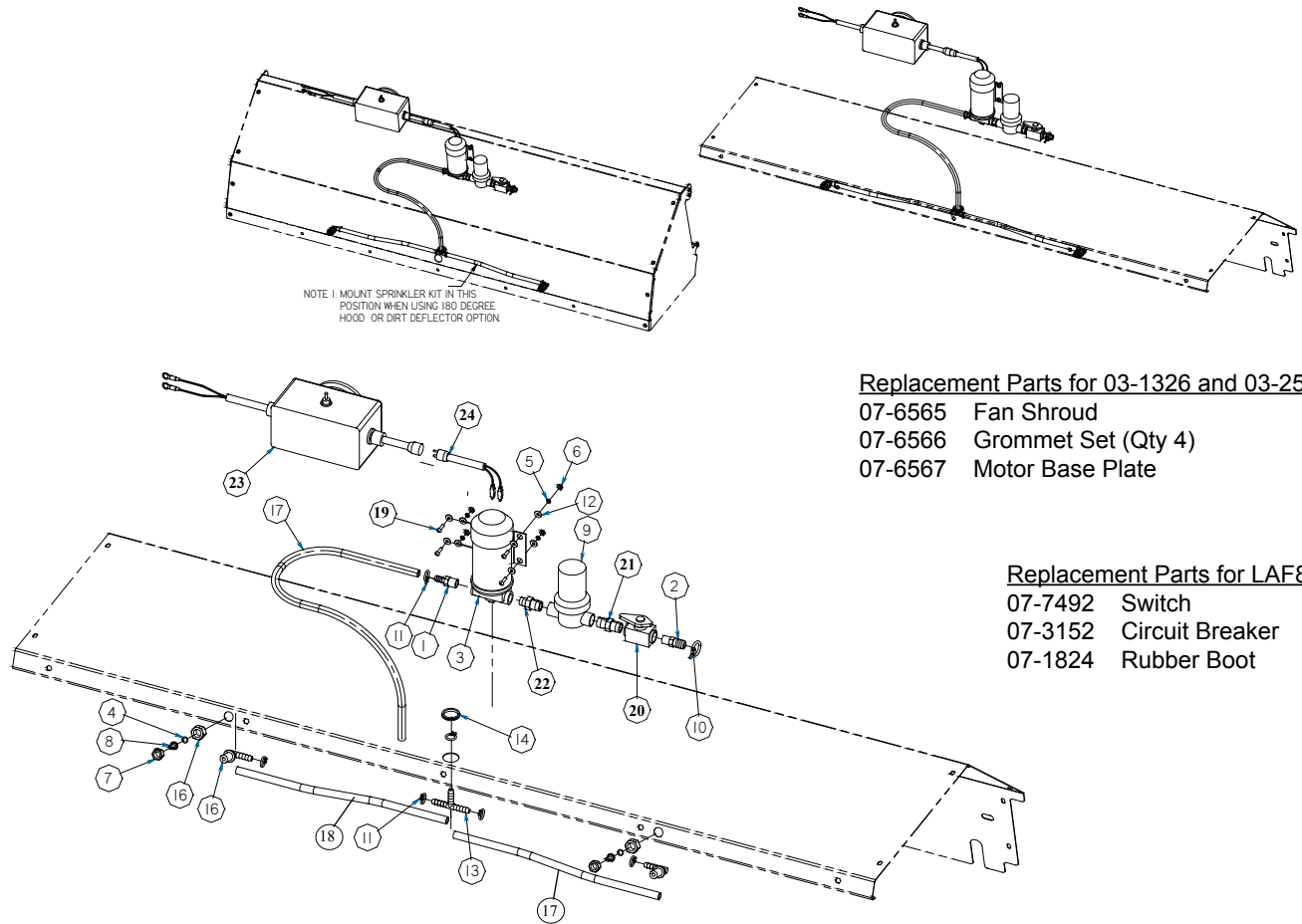

Replacement Parts for 03-1326 and 03-2558 :

- 07-6565 Fan Shroud
- 07-6566 Grommet Set (Qty 4)
- 07-6567 Motor Base Plate

Replacement Parts for LAF8316 :

- 07-7492 Switch
- 07-3152 Circuit Breaker
- 07-1824 Rubber Boot

Item	Part	Qty	Description	Item	Part	Qty	Description
1.	03-0457	1	Barb, 6, 6MP, Nylon	16.	07-4862	2	Nozzle, Elbow, without Clamp
2.	03-1226	1	Barb, 10, 8MP	17.	07-5127	1.25ft	Hose, Clear, Vinyl, 3/8, 5 ft
3.	03-1326	1	Pump, Flojet, Water, 2.1 gpm, 12 volt		07-5127	1.5ft	Hose, Clear, Vinyl, 3/8, 6 ft
	03-2558	1	Pump, Flojet, Water, 2.9 gpm, 24 volt		07-5127	1.75ft	Hose, Clear, Vinyl, 3/8, 7 ft
4.	03-3537	2	O-Ring, #8, Face Seal		07-5127	2ft	Hose, Clear, Vinyl, 3/8, 8 ft
5.	07-0140	4	Washer, Lock, Gr2, #10		07-5127	2.5ft	Hose, Clear, Vinyl, 3/8, 9 ft
6.	07-0141	4	Nut, Hex, Gr2, 10-24	18.	07-5127	1.25ft	Hose, Clear, Vinyl, 3/8, 5 ft
7.	07-0413	2	Nozzle, Cap, Nylon,		07-5127	1.5ft	Hose, Clear, Vinyl, 3/8, 6 ft
8.	07-0414	2	Nozzle, Tip, Brass		07-5127	1.75ft	Hose, Clear, Vinyl, 3/8, 7 ft
9.	07-0532	1	Strainer, Hypro, Water		07-5127	2ft	Hose, Clear, Vinyl, 3/8, 8 ft
10.	07-0547	1	Clamp, Spring, 7/8 Hose		07-5127	2.5ft	Hose, Clear, Vinyl, 3/8, 9 ft
11.	07-0549	6	Clamp, Spring, 5/8 Hose	19.	07-5127	20ft	Hose, Clear, Vinyl, 3/8
12.	07-1430	8	Washer, Flat, #10	20.	07-6862	1	Valve, Shut-Off, 1/2, Nylon
13.	07-3869	1	Fitting, Barb, Tee, Nylon, 3/8	21.	07-6863	1	Fitting, Nipple, 1/2, Nylon
14.	07-4804	1	Grommet, Rubber, 1-1/4 x 7/8 x 1/16	22.	07-6864	1	Fitting, Nipple, 1/2 x 3/8, Nylon
15.	07-4831	4	Screw, BHC, 10-24UNC, 2B x 3/4	23.	LAF8316	1	Wire, Harness, with Box

## Dust Suppression System Spray Bar Nozzle Mount

- |  |  |
|--|--|
| <p><b>12 Volt</b><br/>                 11-4190 (5 Ft [1.3m])<br/>                 11-4045 (6 Ft [1.5m])<br/>                 11-4171 (7 Ft [1.8m])<br/>                 11-4062 (8 Ft [2.0m])<br/>                 11-4262 (9 Ft [2.7m])</p> | <p><b>24 Volt</b><br/>                 11-4379 (8/9 Ft [2.0m])</p> |
|--|--|

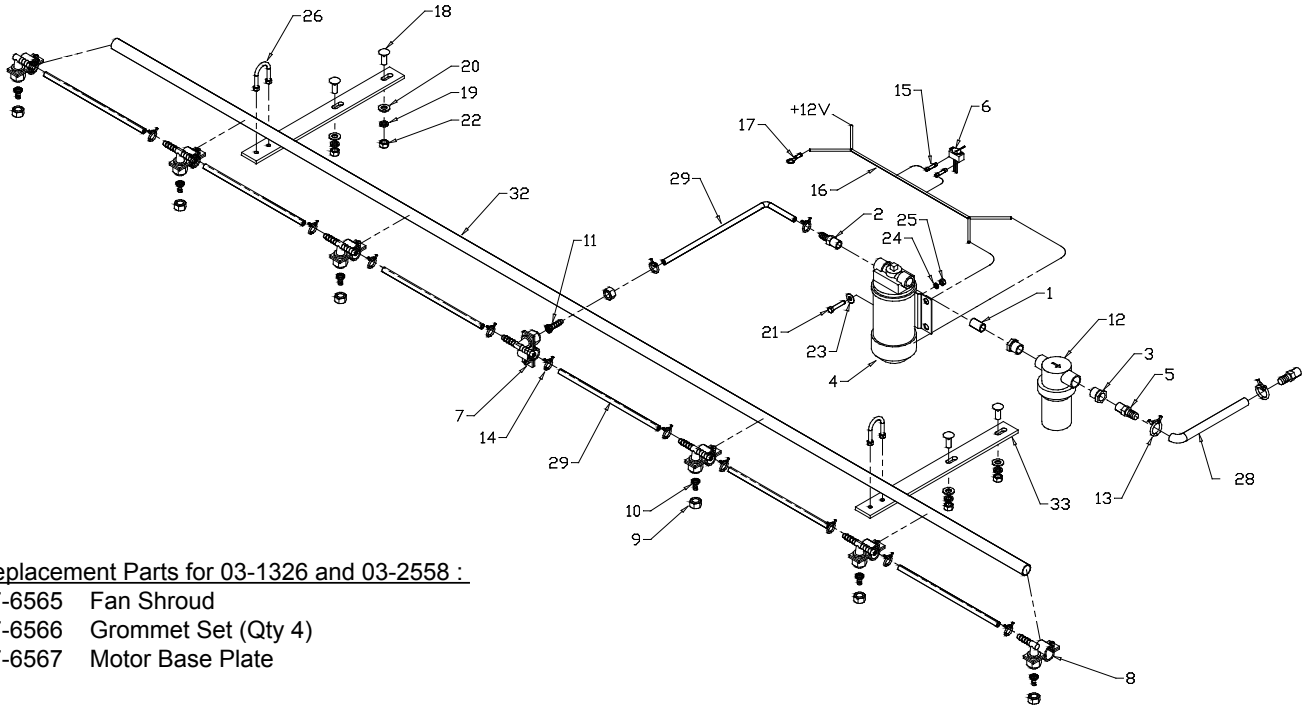

Replacement Parts for 03-1326 and 03-2558 :

- 07-6565 Fan Shroud
- 07-6566 Grommet Set (Qty 4)
- 07-6567 Motor Base Plate

Item	Part	Qty	Description	Item	Part	Qty	Description
1.	03-0076	1	Nipple, 6MP-6MP, BP, Close	18.	07-1716	4	Bolt, Carriage, 3/8-16 x 1
2.	03-0457	1	Barb, 6, 6MP, Nylon	19.	07-1718	4	Washer, Lock, Split, 3/8
3.	03-0819	2	Fitting, 6FP-8MP	20.	07-3279	4	Washer, Flat, 3/8
4.	03-1326	1	Pump, Flojet, Water, 2.1 gpm, 12 volt	21.	07-3638	4	Screw, Cap, 1/4-20 x 1 1/4
	03-2558	1	Pump, Flojet, Water, 2.9 gpm, 24 volt	22.	07-3654	4	Nut, Hex, 3/8-16
5.	03-1709	2	Barb, 10, 6MP, Nylon	23.	07-4032	4	Washer, Flat, 1/4
6.	07-0343	1	Switch, Toggle, 2 Position	24.	07-4038	4	Washer, Lock, Split, 1/4
7.	07-0411	3	Nozzle, Tee, with Clamp (5/6/7)	25.	07-4039	4	Nut, Hex, 1/4-20
	07-0411	5	Nozzle, Tee, with Clamp (8)	26.	07-4673	2	U-Bolt, Standard, 1/4-20 x 1
8.	07-0412	2	Nozzle, Elbow, with Clamp	28.	09-0028	7ft	Hose, Heater, 5/8(5/6/7)
9.	07-0413	5	Nozzle, Cap, Nylon, (5/6/7)		09-0028	10ft	Hose, Heater, 5/8 (8/9)
	07-0413	7	Nozzle, Cap, Nylon, (8)	29.	09-0056	23.75ft	Hose, Heater, 3/8 (5)
10.	07-0414	4	Nozzle, Tip, Brass (5/6/7)		09-0056	25ft	Hose, Heater, 3/8 (6)
	07-0414	6	Nozzle, Tip, Brass (8)		09-0056	26.25ft	Hose, Heater, 3/8 (7)
11.	07-0417	1	Fitting, Barb, Brass, 3/8		09-0056	27.5ft	Hose, Heater, 3/8 (8)
12.	07-0532	1	Strainer, Hypro, Water		09-0056	28.75ft	Hose, Heater, 3/8 (9)
13.	07-0547	2	Clamp, Spring, 7/8 Hose	32.	13-2164	1	Tube, RD, 7/8 x 16 Gauge x 60 (5)
14.	07-0549	10	Clamp, Spring, 5/8 Hose (5/6/7)		11-6684	1	Tube, RD, 7/8 x 16 Gauge x 72 (6/7)
	07-0549	14	Clamp, Spring, 5/8 Hose (8)		13-2812	1	Tube, RD, 7/8 x 16 Gauge x 92.37 (8/9)
15.	07-0867	4	Terminal, Butt	33.	13-10076	2	Plate, Mounting, Sprinkler Bar
16.	07-0917	20ft	Wire, Bulk, Cord, 16 Gauge				
17.	07-0929	1	Terminal, Ring, 3/8, 16-14				

# Sight Indicators

**Kit: 28-9965**

Item	Part	Qty	Description
1.	07-3279	2	Washer, Flat, Gr8, 3/8
2.	07-4036	2	Nut, Hex, Nylock, 3/8-16
3.	07-6597	4	Screw, HFH, CL10.9, M6-1 x 30
4.	13-14857	2	Weld, Sight Indicator
5.	13-9567	2	Ball, 2 1/8, Red, with Hole

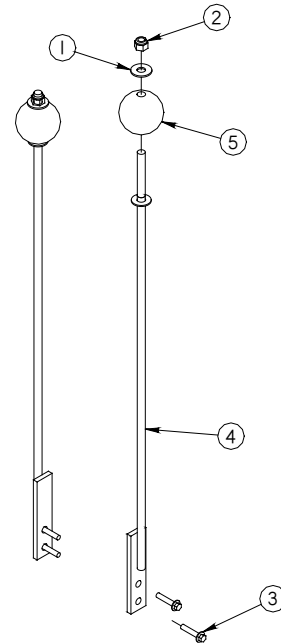

**Kit: 11-5897**

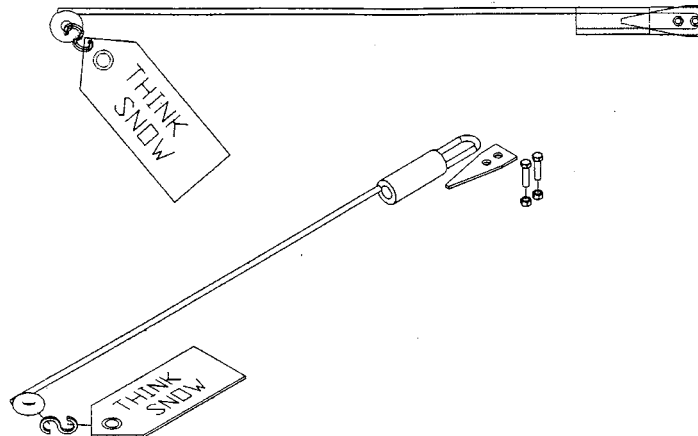

OPTIONS SECTION  
CONVERSION KIT

# Manual to Hydraulic Single Motor

Kit: 28-10133

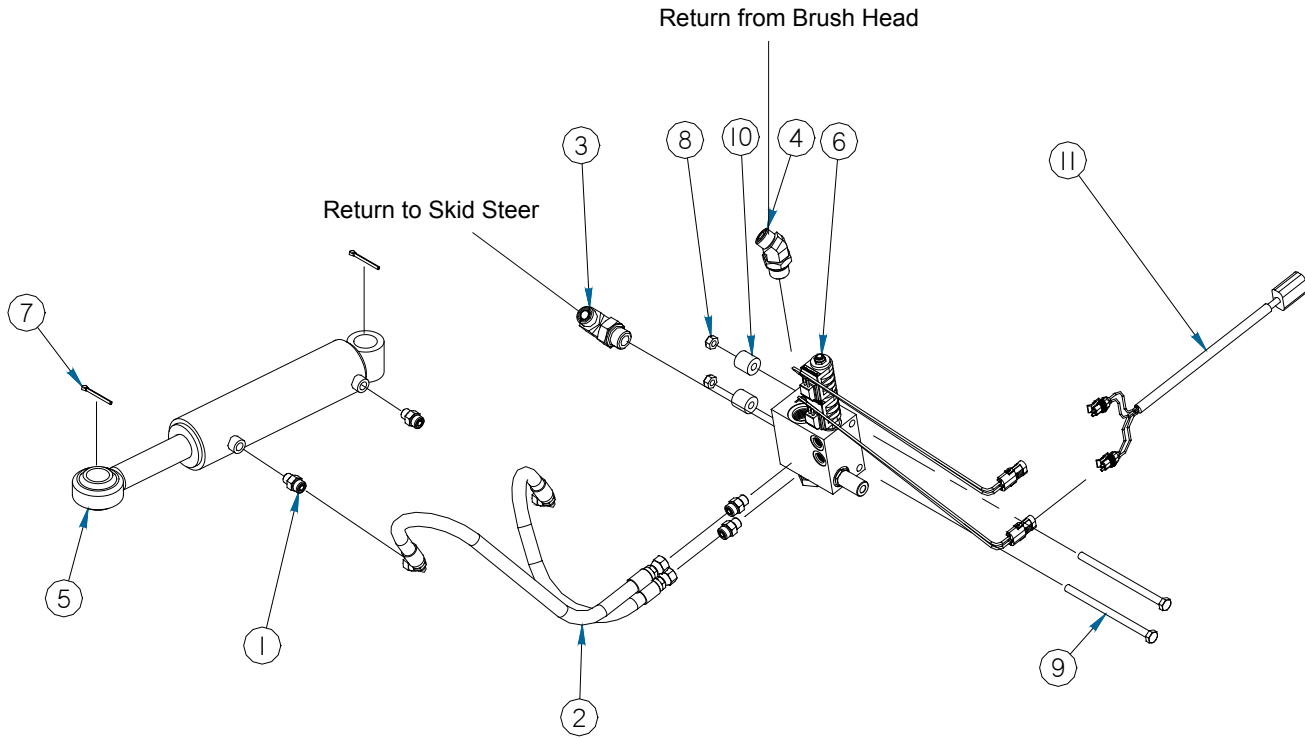

**Item Part Qty Description**

1.	03-2291	4	Fitting, 6MF-6MB, 6F50L0-S
2.	03-2352	2	Hose, .38 x 32, 6FF-6FF90, 4.75K
3.	03-2396	1	Elbow, 90, 10MF-12MP
4.	03-4700	1	Elbow, 45, 10MF-12MB
5.	03-4887	1	Cylinder, 2.50 x 1.38 x 7.50, 3.5K Ball-Cross Tube
6.	03-5215	1	Manifold, Swing, with Relief, 12 Volt
7.	07-0206	2	Pin, Cotter, Gr2, 3/16 x 2
8.	07-4622	2	Nut, Hex, Lock, CL10.9, M10-1.5
9.	07-7131	2	Screw, HHC, CL10.9, M10-1.5 x 160mm
10.	13-11248	2	Bushing, 1 x .406 x 1
11.	LAF9441	1	Wire, Assembly, 9 Ft

Replacement Parts for 03-4887 :

03-4888	Seal Kit
03-5035	Cylinder Rod

Replacement Parts for 03-5215 :

07-7150	Valve, Cartridge, Pressure, Comp
07-7151	Valve, Cartridge, Relief
07-7152	Valve, Cartridge, Directional
07-7153	Coil, 12 Volt

# Manual to Hydraulic Dual Motor

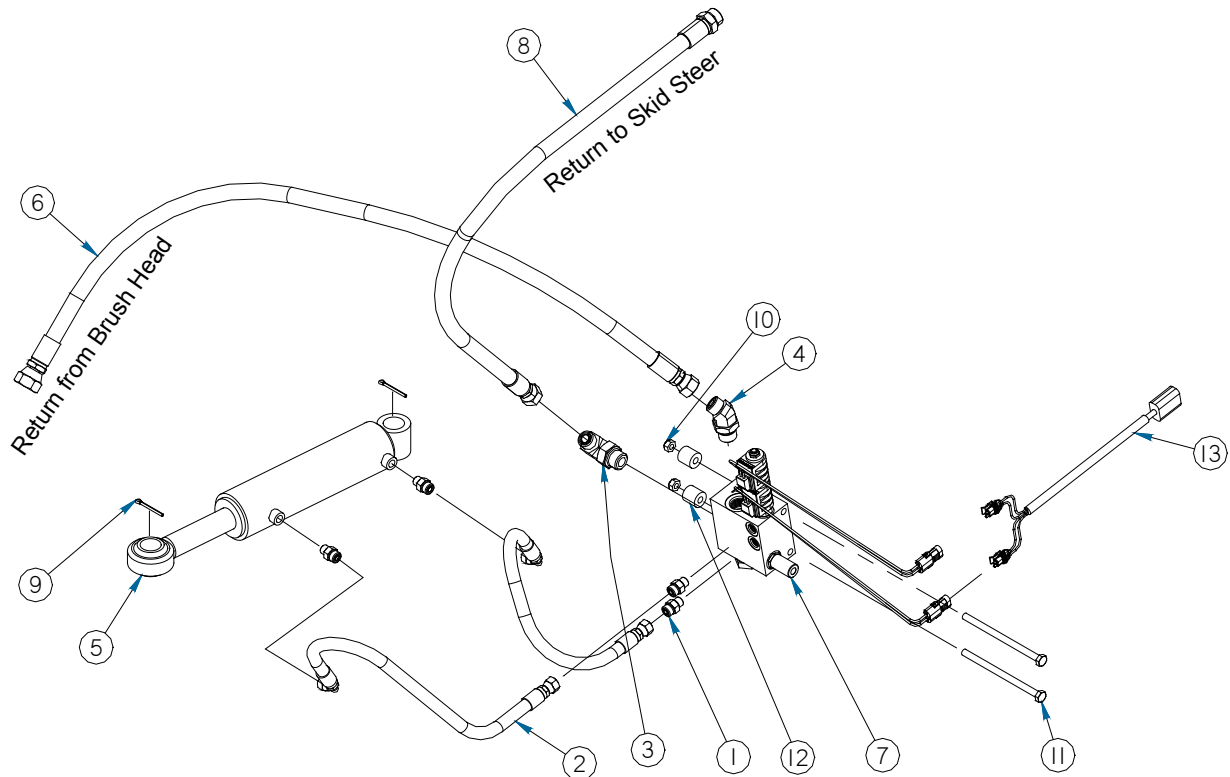
**Kit: 28-10134**

Item	Part	Qty	Description
1.	03-2291	4	Fitting, 6MF-6MB, 6F50L0-S
2.	03-2352	2	Hose, .38 x 32, 6FF-6FF90, 4.75K
3.	03-2396	1	Elbow, 90, 10MF-12MB
4.	03-4700	1	Elbow, 45, 10MF-12MB
5.	03-4887	1	Cylinder, 2.50 x 1.38 x 7.50, 3.5K Ball-Cross Tube
6.	03-5173	1	Hose, .63 x 60, 10FF-12FF, 3.625K
7.	03-5215	1	Manifold, Swing, with Relief, 12 Volt
8.	03-5385	1	Hose, .63 x 80, 10FF-10MB, 3K, HS
9.	07-0206	2	Pin, Cotter, Gr2, 3/16 x 2
10.	07-4622	2	Nut, Hex, Lock, CL10.9, M10-1.5
11.	07-7131	2	Screw, HHC, CL10.9, M10-1.5 x 160mm
12.	13-11248	2	Bushing, 1 x .406 x 1
13.	LAF9441	1	Wire, Assembly, 9 Ft

### Replacement Parts for 03-4887 :

03-4888 Seal Kit  
03-5035 Cylinder Rod

### Replacement Parts for 03-5215 :

07-7150 Valve, Cartridge, Pressure, Comp  
07-7151 Valve, Cartridge, Relief  
07-7152 Valve, Cartridge, Directional  
07-7153 Coil, 12 Volt

# Notes

---

---

# Appendix

---

## QC Series Angle Brooms

---

### Table of Contents



Bolt Torque Specifications.....	55
Hydraulic Fittings Torque Specifications .....	56-57
Glossary .....	58-59
Warranty Information.....	60-61

APPENDIX  
TORQUE SPECS.**BOLT TORQUE SPECIFICATIONS****GENERAL TORQUE SPECIFICATION TABLES**

Use the following charts when determining bolt torque specifications when special torques are not given. Always use grade 5 or better when replacing bolts.



**SAE BOLT TORQUE SPECIFICATIONS**

**NOTE:** The following torque values are for use with extreme pressure lubricants, plating or hard washer applications increase torque 15% when using hardware that is unplated and either dry or lubricated with engine oil.

Bolt Size		SAE GRADE 5 TORQUE				SAE GRADE 8 TORQUE				Bolt head identification marks as per grade. NOTE: Manufacturing Marks Will Vary
		Pounds Feet		Newton-Meters		Pounds Feet		Newton-Meters		
Inches	Millimeters	UNC	UNF	UNC	UNF	UNC	UNF	UNC	UNF	
1/4	6.35	8	9	11	12	10	13	14	18	<p>GRADE 2</p>  <p>GRADE 5</p>  <p>GRADE 8</p> 
5/16	7.94	14	17	19	23	20	25	27	34	
3/8	9.53	30	36	41	49	38	46	52	62	
7/16	11.11	46	54	62	73	60	71	81	96	
1/2	12.70	68	82	92	111	94	112	127	152	
9/16	14.29	94	112	127	152	136	163	184	221	
5/8	15.88	128	153	174	207	187	224	254	304	
3/4	19.05	230	275	312	373	323	395	438	536	
7/8	22.23	340	408	461	553	510	612	691	830	
1	25.40	493	592	668	803	765	918	1037	1245	
1-1/8	25.58	680	748	922	1014	1088	1224	1475	1660	
1-1/4	31.75	952	1054	1291	1429	1547	1700	2097	2305	
1-3/8	34.93	1241	1428	1683	1936	2023	2312	2743	3135	
1-1/2	38.10	1649	1870	2236	2535	2686	3026	3642	4103	

**METRIC BOLT TORQUE SPECIFICATIONS**

**NOTE:** The following torque values are for use with metric hardware that is unplated and either dry or lubricated with engine oil. Reduce torque 15% when using hardware that has extreme pressure lubricants, plating or hard washer applications.

Bolt head identification marks as per grade.		
		

Size of Bolt	Grade No.	Pitch (mm)	Pounds Feet	Newton-Meters	Pitch (mm)	Pounds Feet	Newton-Meters
M6	5.6	1.0	3.6-5.8	4.9-7.9	-	-	-
	8.8		5.8-4	7.9-12.7		-	-
	10.9		7.2-10	9.8-13.6		-	-
M8	5.6	1.25	7.2-14	9.8-19	1.0	12-17	16.3-23
	8.8		17-22	23-29.8		19-27	25.7-36.6
	10.9		20-26	27.1-35.2		22-31	29.8-42
M10	5.6	1.5	20-25	27.1-33.9	1.25	20-29	27.1-39.3
	8.8		34-40	46.1-54.2		35-47	47.4-63.7
	10.9		38-46	51.5-62.3		40-52	54.2-70.5
M12	5.6	1.75	28-34	37.9-46.1	1.25	31-41	42-55.6
	8.8		51-59	69.1-79.9		56-68	75.9-92.1
	10.9		57-66	77.2-89.4		62-75	84-101.6
M14	5.6	2.0	49-56	66.4-75.9	1.5	52-64	70.5-86.7
	8.8		81-93	109.8-126		90-106	122-143.6
	10.9		96-109	130.1-147.7		107-124	145-168
M16	5.6	2.0	67-77	90.8-104.3	1.5	69-83	93.5-112.5
	8.8		116-130	157.2-176.2		120-138	162.6-187
	10.9		129-145	174.8-196.5		140-158	189.7-214.1
M18	5.6	2.0	88-100	119.2-136	1.5	100-117	136-158.5
	8.8		150-168	203.3-227.6		177-199	239.8-269.6
	10.9		175-194	237.1-262.9		202-231	273.7-313
M20	5.6	2.5	108-130	146.3-176.2	1.5	132-150	178.9-203.3
	8.8		186-205	252-277.8		206-242	279.1-327.9
	10.9		213-249	288.6-337.4		246-289	333.3-391.6

**NOTE** - Nylock nuts are utilized when greater resistance to vibrating loose is required, and greater operating temperatures are not a factor. In addition, like lock nuts, nylock nuts have a safety feature that if the bolt does vibrate loose, the nut will remain on the screw. Install nylock nuts to the standard torque shown above.



# Hydraulic Torque Specifications

## Face Seal: Assembly, Tube to Fitting

**Note** - Face seal fittings have the most reliable sealing method and therefore, should be used whenever possible.

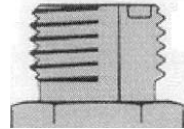

## Installation

1. Make sure threads and sealing surfaces are free of burrs, nicks, scratches, or any foreign materials.
2. Install proper SAE o-ring to end of fitting if not already installed. Ensure o-ring is fully seated and retained properly.
3. Lubricate o-ring with a light coating of clean hydraulic oil.
4. Position tube and nut squarely on face seal of fitting and tighten nut finger tight.

## Torque Values:

SAE Dash Size	Tube Size	In-lbs Thread Size	Ft-lbs	
-4		9/16 - 18	220 ± 10	18 ± 1
-6		11/16 - 16	320 ± 25	27 ± 2
-8		13/16 - 16	480 ± 25	40 ± 2
-10		1 - 14	750 ± 35	63 ± 3
-12		1 3/16 - 12	1080 ± 45	90 ± 4
-16		1 7/16 - 12	1440 ± 90	120 ± 8
-20		1 11/16 - 12	1680 ± 90	140 ± 8
-24		2 - 12	1980 ± 100	165 ± 8

**NOTE** - ft-lb may be converted to NewMeters by multiplying by 1.35582.  
**NOTE** - in-lbs may be converted to Newton Meters by multiplying by 0.11298.

APPENDIX  
TORQUE SPECS.

## Hydraulic Torque Specifications

### Straight Thread O-ring Fitting: Assembly, Fitting to Port

**NOTE** - Straight thread o-ring fittings are utilized to adapt hydraulic systems to motors, pumps, cylinders, and valves.



### Installation (Adjustable Fitting)

1. Make sure threads and sealing surfaces are free of burrs, nicks, scratches, or any foreign materials.
2. Install proper SAE o-ring on port end of fitting if not already installed. Ensure o-ring is fully seated and retained properly.
3. Lubricate o-ring with a light coating of clean hydraulic oil.
4. Back off nut as far as possible and push washer up as far as possible. (Figure 4 & 5)
5. Screw fitting into port. Hand tighten fitting until backup washer contacts face of port. (Figure 6)
6. To position the fitting, unscrew to desired position, but not more than one full turn.
7. Hold fitting in position with wrench. Using appropriate torquing device, tighten nut to given torque rating from the table in section. (Figure 7)

### Torque Values

Figures 4, 5, 6 and 7

Fitting Size	SAE Port Thread Size	In-Lbs	Ft-Lbs
-4	7/16 - 20	190 ± 10	16 ± 1
-6	9/16 - 18	420 ± 15	35 ± 1
-8	3/4 - 14	720 ± 25	60 ± 2
-10	7/8 - 14	1260 ± 50	105 ± 5
-12	1 1/16 - 12	1680 ± 75	140 ± 6
-16	1 5/16 - 12	2520 ± 100	210 ± 8
-20	1 5/8 - 12	3100 ± 150	260 ± 12
-24	1 7/8 - 12	3800 ± 150	315 ± 12

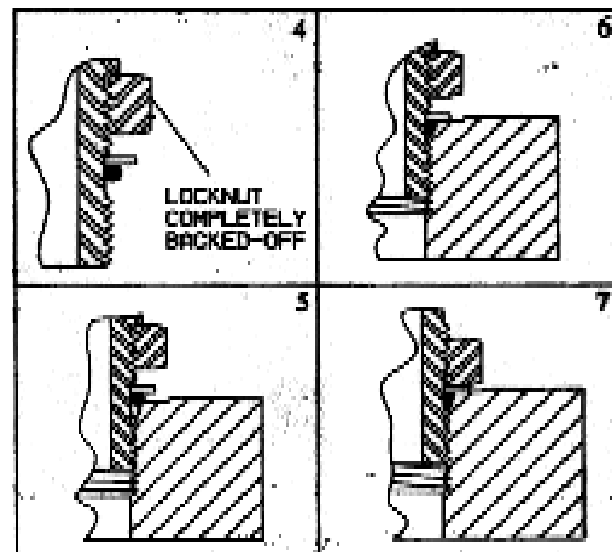

**NOTE** - ft-lb may be converted to NewMeters by multiplying by 1.35582.  
**NOTE** - in-lbs may be converted to Newton Meters by multiplying by 0.11298.

APPENDIX  
GLOSSARY

**angle or angle assembly** - portion of the sweeper that allows the brush head assembly to angle.

**BP** - black pipe.

**brush head assembly** - assembly that includes the core, hood, and brush frame.

**brush pattern** - area of dirt removed from sweeping surface; with a properly adjusted sweeper; the pattern is the same width for the entire length.

**castellated** - having battlements like a castle.

**caution** - indicates a potentially hazardous situation which, if not avoided, may result in minor or moderate injury.

**core** - weldment that holds brush sections.

**danger** - indicates an imminently hazardous situation which, if not avoided, will result in death or serious injury.

**F** - female.

**FS** - face seal.

**front** - side that is in front when facing the normal forward direction of travel of the machine.

**gpm** - gallons per minute.

**HP** - high pressure.

**hood** - brush shield.

**hydraulic angle kit** - means of swinging an assembly hydraulically.

**important** - used for instructions when machine damage may be involved.

**in.** - inches.

**kph** - kilometers per hour.

**lb** - pounds.

**left-hand** - side that is on the left when facing the normal forward direction of travel of the machine.

**lift cylinder** - means of raising the brush head assembly hydraulically.

**lps** - liters per second.

**M** - male.

**mm** - millimeters.

**mph** - miles per hour.

**manual angle kit** - means of swinging the brush head assembly mechanically.

**mid pump unit** - sweeper in which the pump is mounted on the mid PTO.

**mounting assembly** - portion of the sweeper that attaches to the prime mover; designed specifically for each prime mover.

**NPT** - national pipe thread.

**note** - indicates supplementary information.

**OR** - o-ring.

**psi** - pounds per square inch.

**PTO** - power take off; shaft on the prime mover used to drive attachments.

**plate swing** - swing assembly that includes a half-moon plate.

**power pack** - auxiliary hydraulic package used when prime mover hydraulics do not have enough flow available.

**prime mover** - refers to the tractor, truck, loader or other vehicle to which a sweeper is attached.

**qty** - quantity.

**quick change core** - core designed in a way that allows brush sections to be changed without removing hoses from motors.

**rpm** - revolutions per minute.

**rear** - side that is in rear when facing the normal forward direction of travel of the machine.

**rear pump unit** - sweeper in which the pump is mounted on a rear PTO.

**retainer** - removable plate or set of plates that keeps sections on the core.

**right-handed** - side that is on the right when facing the normal forward direction of travel of the machine.

**section** - single brush wafer.

**section set** - replacement brush wafers.

**sprinkler system** - system that sprays water ahead of the sweeper used to reduce dust.

**sprinkler tank** - assembly that includes the water reservoir and mounting used in a sprinkler system.

**stands** - devices designed to keep the components off the ground when the sweeper is dismounted.

**swing or swing assembly** - portion of the sweeper that allows the brush head assembly to angle.

**swing cylinder** - means of angling the brush head assembly hydraulically.

**tank assembly, hydraulic** - assembly that includes the hydraulic reservoir, filter and fittings; may also incorporate valves.

**warning** - indicates a potentially hazardous situation which, if not avoided, could result in death or serious injury.

**weld** - weldment.

**windrow** - pile of debris.

**zerk** - grease fitting.

APPENDIX  
WARRANTY INFORMATION



**Warranty Registration Form & Delivery Inspection Report**

**IMPORTANT!** Warranty **Void** if card is not returned within 10 days.

All Applicable sections **must** be filled in.

*This section to be filled out and signed by Dealer at time of delivery.*

Customer's Name _____	Dealer's Name _____
Address _____	Address _____
City _____ State ___ Zip _____	City _____ State ___ Zip _____
Phone _____	

Loader / Tractor Model \_\_\_\_\_  
 Delivery Date \_\_\_\_\_  
 Brand & Model # \_\_\_\_\_  
 Serial # \_\_\_\_\_

**CHECK ONE:**

<input type="checkbox"/> Agricultural Use	<input type="checkbox"/> Construction Use
<input type="checkbox"/> Landscape Use	<input type="checkbox"/> Other _____

**Dealer Inspection** *(check items applicable)*

<input type="checkbox"/> All Decals Installed (see operator's manual)	<input type="checkbox"/> Review Operating & Safety Instructions
<input type="checkbox"/> Hydraulic Fittings Tight & Free of Leaks	<input type="checkbox"/> Guards & Covers in Place & Secure
<input type="checkbox"/> Fastners Tight	<input type="checkbox"/> Does Product Function Properly

I have thoroughly instructed the buyer on the above described equipment. This review included: The Operator's Manual content, equipment care, adjustments, safe operation and applicable warranty policy.

Dealer Rep. Signature: \_\_\_\_\_ Date: \_\_\_\_\_

*This section to be completed and signed by the Owner*

QUALITY ASSURANCE RATING	1=Excellent	2=Good	3=Average	4=unsatisfactory	5=poor
Question	Paladin Light Construction		Local Dealer		
Quality of Product: Appearance	_____				
Construction	_____				
Quality of Service	_____		_____		
Value (Priced Fairly)	_____		_____		
Does it perform as claimed	_____				

The above described equipment and Operator's Manual have been received by me and I have been thoroughly instructed as to care, adjustments, safe operation and applicable warranty policy.

Owner's Signature: \_\_\_\_\_ Date: \_\_\_\_\_

**NOTE!** Make one copy each for the dealer's and owner's records. Fax or mail to

Paladin Light Construction Group  
 Bradco, FFC, Harley, McMillen, Sweepster  
 2800 North Zeeb Rd Dexter MI 48130  
 Fax 734.996.9014



## **SWEEPSTER ATTACHMENTS LLC**

### **Limited 12 Month Warranty**

Thank you for purchasing a Sweepster Attachments, LLC. product. Warranty protection is valid only when this Warranty Registration is completed and signed by the customer and dealer, and mailed to Sweepster Attachments, LLC. I hereby acknowledge that I have received a copy of the owners Limited Warranty and I accept the terms therein.

For a period of 12 months from the date of delivery of product to the original user, Sweepster Attachments, LLC. warrants each product to be free from manufacturing defects, subject to the limitations contained in this policy.

This warranty does not apply to defect caused, in whole or in part, by unreasonable use while in the possession of the user, including, but not limited to: failure to properly set up product; failure to provide reasonable and necessary maintenance; normal wear; routine tune ups or adjustments; improper handling or accidents; operation at speed or load conditions contrary to published specification; improper or insufficient lubrication; improper storage. This warranty is also not a guarantee that performance of each product will meet the expectations of the purchaser.

Sweepster Attachments, LLC. shall not be liable for consequential damages of any kind, including, but not limited to: consequential labor costs or transportation charges in connection with the replacement or repair of defective parts; lost time or expense which may have accrued because of said defects. In no event shall Sweepster Attachments, LLC.'s total liability hereunder exceed the product purchase price.

Sweepster Attachments, LLC. makes no warranty with respect to trade accessories or any component or accessory of the product which was not manufactured by Sweepster Attachments, LLC. including any purchased components of any kind. These are subject to the warranties of their respective manufacturers. The warranty will be considered void if the product or any part of the product is modified or repaired in any way not expressly authorized by Sweepster Attachments, LLC. or if closed components are disassembled prior to return. Closed components include, but are not limited to: gearboxes, hydraulic pumps, motors, cylinders, and actuators.

Our obligation under the warranty is expressly limited, at our option, to the replacement or repair at Sweepster Attachments, LLC or at a service facility designated by us, or such part or parts as inspection shall disclose to have been defective. We are not responsible for unauthorized repairs or replacements. Any implied or statutory warranties, including any warranty of merchantability or fitness for a particular purpose, are expressly limited to the duration of this written warranty. We make no other express or implied warranty, nor is anyone authorized to make any on our behalf. This warranty cannot be extended, broadened, or changed except in writing by an authorized officer of Sweepster Attachments, LLC.