

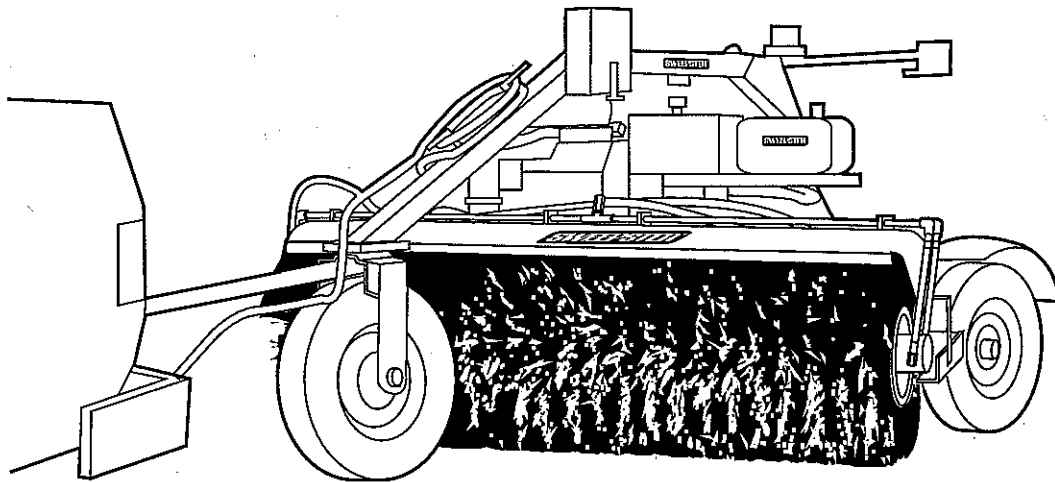

P Series



SWEEPSTER, Inc.
2800 N. Zeeb Road • Dexter, MI 48130
(734) 996-9116 • FAX (734) 996-9014
1-800-456-7100
www.sweepster.com

51-2507-4

Contents

Introduction	4-5	Carrier Assembly (3 and 4Wheel)	24-25
Serial & Part Numbers	4	Casters	26-27
Importance of this Manual	5	Carrier Assembly (2Wheel)	28-29
Purpose of Sweeper	5	Hitch Assemblies	30-37
Safety Alert Symbol	5	Brush Head Assembly	38-39
Contacting SWEEPSTER	5	Swing Assembly	40-41
Terms Used in Manual	5	Engine Drive Assembly	42-43
Optional Equipment	5	Option – Sprinkler Assembly	44-45
Specifications & Features	5	Control Box Assemblies	46-47
Warranty	5	Storage	48
Safety Information	6-7	Torque Values	49
Read this Manual	6	Warranty Information	50-51
Hazard Definitions	6	Glossary	52-53
Operation	6		
Service & Repair	7		
Safety Signs & Labels	8-9		
Important	8		
Representations of labels	9		
Installation	10-13		
Reference Diagram	10		
Engine Oil Level	11		
Engine Fuel	11		
Battery Installation	11		
Hitch	11		
Tail Light Installaton	12		
Mounting Brush Head	13		
Adjustments	15-19		
Leveling Main Frame	15		
Support Yokes	15		
Leveling Brush Head	16-17		
Brush Pattern	18		
Spring-Chain Assembly	18		
Transport Chain	19		
Maintenance	20-23		
Brush Section Replacement	20		
Tightening Drive Chain	20		
Sprocket Alignment	20		
Hydraulic Swing Lift	20		
Lubrication Points	21		
Maintenance Schedule	22		
Notes	23		

Introduction

Serial & Part Numbers

On your unit you will find a serial number plate and/or part number plate(s). The numbers on these plates are very important if you wish to order parts or accessories. For your convenience, record numbers in the appropriate spaces below.

SWEEPSTER	
Model #	Serial #
<input type="text"/>	<input type="text"/>
Empty	GVW
<input type="text"/>	<input type="text"/>
Dexter, MI 48130 1-800-456-7100	

SWEEPSTER	
Dexter, MI 48130 1-800-456-7100	
Part Number	Date
<input type="text"/>	<input type="text"/>

SWEEPSTER	
Dexter, MI 48130 1-800-456-7100	
Part Number	Date
<input type="text"/>	<input type="text"/>

SWEEPSTER	
Dexter, MI 48130 1-800-456-7100	
Part Number	Date
<input type="text"/>	<input type="text"/>

Introduction

Importance of this Manual

This operator's manual should be regarded as part of the sweeper. Suppliers of both new and secondhand sweepers are advised to keep documentation indicating that this manual was provided with the sweeper.

The manual contains information regarding installation, operation and maintenance required for this sweeper model and optional equipment. It also includes detailed parts lists.

Purpose of Sweeper

This sweeper is designed solely for use in construction cleanup, road maintenance, grounds maintenance, snow removal and similar operations. Use in any other way is considered contrary to the intended use. Compliance with and strict adherence to operation, service and repair conditions, as specified by the manufacturer, are also essential elements of the intended use.

This sweeper should be operated, serviced and repaired only by persons who are familiar with its characteristics and acquainted with relevant safety procedures.

Accident prevention regulations, all other generally recognized safety regulations and all road traffic regulations must be observed at all times.

Any modifications made to this sweeper may relieve the manufacturer of liability for any resulting damage or injury.

Safety Alert Symbol

 This safety alert symbol indicates important safety messages in this manual. When you see this symbol, be alert to the possibility of injury. Carefully read the message that follows and inform other operators.

Contacting SWEEPSTER

If you have any questions about information in this manual or need to order parts, please call, write, FAX or e-mail SWEEPSTER.

SWEEPSTER, Inc.
2800 North Zeeb Road
Dexter, Michigan 48130
Phone: (734) 996-9116 • (800) 456-7100
FAX: (734) 996-9014
e-mail: sweep@sweepster.com

For help with installation, operation or maintenance procedures, contact our Technical Service Department. Direct product questions and parts orders to our Sales Department.

When ordering parts or accessories, be prepared to give the following information:

- Sweeper model, serial number and date of purchase
- Prime mover make and model
- Part number, description and quantity

Terms Used in Manual

Right-hand, left-hand, front and rear are determined from the operator's perspective (either the operator's seat or standing behind a walk-behind unit), facing forward in the normal operating position.

Prime mover refers to the tractor, truck, loader or tow vehicle that a sweeper is mounted on or towed by.

Optional Equipment

Installation instructions for optional equipment, if applicable, appear with parts lists in the back of the manual.

Specifications & Features

Due to continuous product improvement, specifications and features may change without notice.

Warranty

To validate the warranty for this unit, fill out the warranty card or warranty pages located at the back of this manual. Then, send this information to SWEEPSTER.

Safety Information

Read this Manual

Read all safety information in this manual. All operators must read and understand the entire contents of this manual before sweeping. General safety practices are listed on Safety Information pages and specific safety information is located throughout this manual.

Hazard Definitions

Four hazard classifications are used in this manual. They are

 **CAUTION** – Indicates a potentially hazardous situation which, if not avoided, may result in minor or moderate injury.

 **WARNING** – Indicates a potentially hazardous situation which, if not avoided, could result in death or serious injury.

 **DANGER** – Indicates an imminently hazardous situation which, if not avoided, will result in death or serious injury.

IMPORTANT – Used for instructions when machine damage may be involved.

Operation

 **CAUTION** – A sweeper is a demanding machine. Only fully trained operators or trainee operators under the close supervision of a fully trained person should use this machine.

Before sweeping:

- Learn sweeper and prime mover controls in an off-road location.
- Be sure that you are in a safe area, away from traffic or other hazards.
- Check all hardware holding the sweeper to the prime mover, making sure it is tight.
- Make sure all hydraulic fittings and hardware are tight.
- Replace any damaged or fatigued hardware with properly rated fasteners.

- Check prime mover tire pressure before sweeping.
- Check tire ratings to be sure they match the prime mover load. Weigh the sweeper end of the prime mover, if necessary, to insure proper tire rating.
- Remove from the sweeping area all property that could be damaged by debris flying from the sweeper.
- Be sure all persons not operating the sweeper are clear of the sweeper discharge area.
- Always wear proper apparel such as a long-sleeve shirt buttoned at the cuffs; safety glasses, goggles or a face shield; ear protection; and a dust mask.

When sweeping, adhere to all government rules, local laws and other professional guidelines for your sweeping application.

 **WARNING** – Never raise the sweeper more than a few feet off the ground. The sweeper can tip back or the prime mover can tip over causing death or serious injury.

Before leaving the operator's area for any reason – lower the sweeper to the ground, stop the prime mover engine, set the brakes and remove the key from the ignition.

Minimize flying debris – use the slowest brush speed that will do the job.

Keep hands, feet, hair and loose clothing away from all moving parts.

Leave the brush hood (shield) and all other shields and safety equipment in place when operating the sweeper and prime mover.

Be aware of the extra weight and width a sweeper adds. Reduce travel speed accordingly.

When sweeping on rough terrain, reduce speed to avoid "bouncing" the sweeper. Loss of steering can result.

Never sweep toward people, buildings, vehicles or other objects that can be damaged by flying debris.

Safety Information

Service & Repair



CAUTION – Do not modify the sweeper in any way. Personal injury could result. If you have questions, contact your dealer or SWEEPSTER.

Repair or adjust the sweeper in a safe area, away from road traffic and other hazards.

Before adjusting or servicing the sweeper – lower the sweeper to the ground, stop the prime mover engine, set the brakes and remove the key from the ignition.

When working on or around the sweeper, lower it to the ground or secure it with transport chains or cylinder-stop locks.

Stop the prime mover engine and cycle control levers to release hydraulic pressure before servicing or adjusting sweeper hydraulic systems.



WARNING – Escaping hydraulic fluid can have enough pressure to penetrate the skin, causing serious personal injury.

Safety Signs & Labels

Important

Always keep safety signs clean and readable, and always replace any damaged or missing safety signs with new ones from SWEEPSTER.

For representations of safety signs and labels, refer to page 9.

Item	Part	Qty	Description
1.	50-0004	1	Label, Serial Number
2.	50-0005	1	Label, Danger, Lights and Chains
3.	50-0006	1	Label, Danger, Gasoline
4.	50-0575	4	Label, Danger, No Riders
5.	50-0574	1	Label, Caution, Read, Manual
	50-0577	1	Label, Caution, Running Sweeper & Engine
6.	50-0076-1	4	Label, Caution, Pinch Point
7.	50-0026	6	Label, Tie Down, Here
8.	50-0184	2	Label, Small, White, Logo
9.	50-0186	5	Label, Small, Black, Logo
10.	50-0192	1	Label, Large, Black, Logo

Safety Signs & Labels

Representations of Labels

Locations shown on page 8.



1. 50-0004

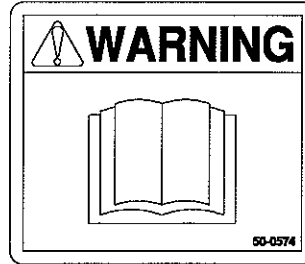

5. 50-0574



5. 50-0577



2. 50-0005



6. 50-0076-1

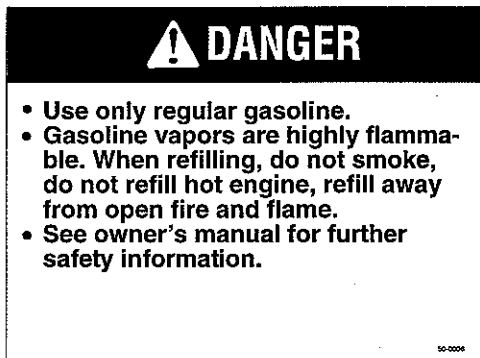

3. 50-0013-1



7. 50-0026



8. 50-0185



9. 50-0186



4. 50-0575



10. 50-0252

Installation

Reference Diagram

1. Monarch Hydraulic Unit (Swing-Lift)
2. Main Frame
3. Battery Holder
4. Swing Frame Assembly
5. Engine Mounting Frame
6. Brush Head Assembly
7. Fuel Tank Mounting Frame
8. Drive Shaft
9. Brush Hood
10. Control Box
11. Hitch Bolts and Hardware
12. Brush Sections
13. Core
14. Swing Cylinder
15. Fuel Tank
16. Brush Head Drive Shield
17. Bristle Shield
18. Lift Cylinder
19. Spring-Chain Assembly
20. Transport Chain
21. Safety-Chain Hitch
22. Serial Number Plate
23. Brush Head Mounting Plate

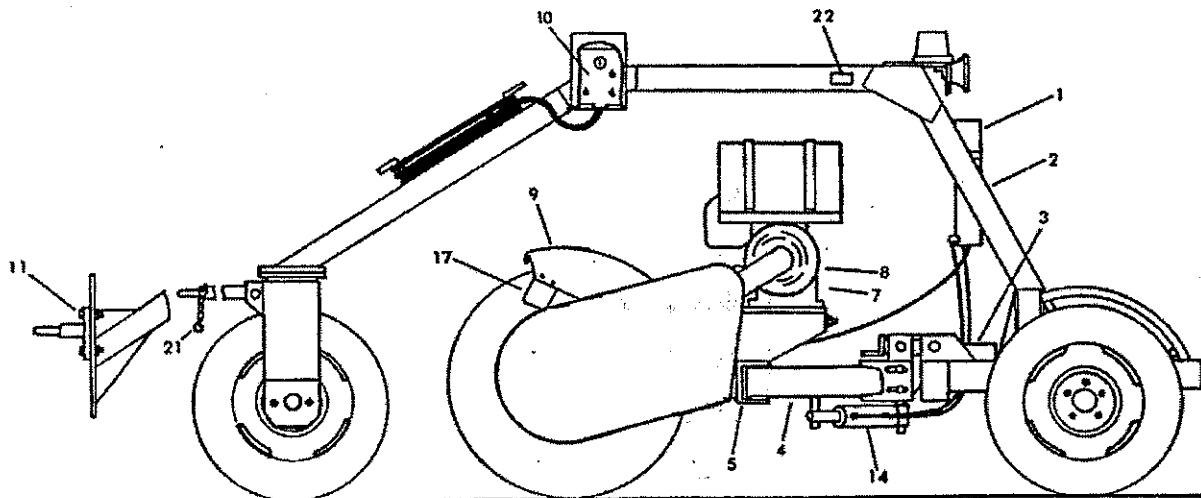
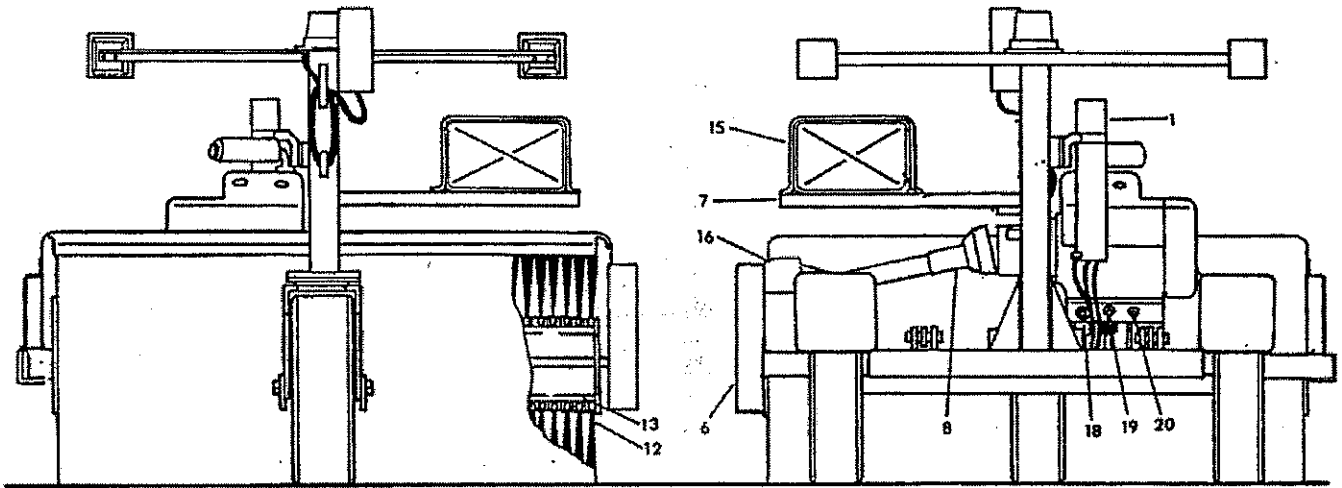

Installation

Engine Oil Level

Wisconsin Engine Only

Check engine crankcase oil level with dipstick located at the back, left side of the engine, (See Figure below).

Add oil as necessary (see "Grade of Oil" chart in Wisconsin Starting and Operating Manual supplied with this sweeper). Fill through the oil filler (vent cap) to the level indicated by the FULL mark on the dip stick.

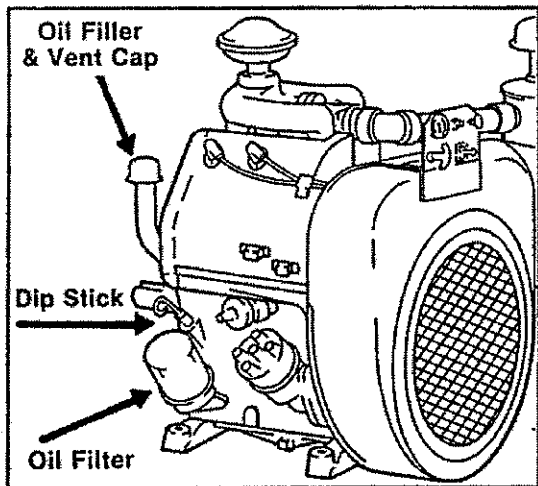

NOTE – If sweeper is equipped with an optional engine, refer to the operator's manual supplied with this sweeper for those engines.

Engine Fuel

Wisconsin Gasoline Engine Only

Fill the fuel tank with regular grade gasoline.

NOTE – If sweeper is equipped with an optional engine, refer to the operator's manual supplied with this sweeper for those engines.

Battery Installation

A battery is not supplied with this unit. A 12 volt 70 amp battery is recommended for use with Wisconsin Engines. This system is negative ground.

1. Place battery in holder located behind swing assembly on carrier frame. Secure battery with attached rubber strap.
2. Connect short battery cable (attached to frame of sweeper) to negative post of battery.
3. Connect long battery cable (attached to the Monarch solenoid) to positive post of battery.



CAUTION – Never allow battery acid to come in contact with eyes, skin, clothing, or any surface. Flush immediately with large amounts of water and consult a doctor at once if acid gets on skin or in eyes.

Hitch

Connect drawbar, pintle, or ball hitch to tow vehicle.



CAUTION – Be sure tow vehicle and tow vehicle hitch are rated to carry the Gross Vehicle Weight (G.V.W.) of this sweeper (weigh sweeper with water tank full to determine the G.V.W. of sweeper).

Two-Wheeled Sweepers Only

Adjust hitch height as required to level top of main-frame front-to-rear. Hitch mounting bolts must be tight and secured with lock washers.



CAUTION – Use only grade 8 bolts, nuts, and washers for replacement in hitch.

Installation

Tail Light Hook-Up

Refer to the figure below for tail light wiring diagram.

NOTE – The green and yellow wires connected to stop light terminals also operate turn signals.

Connect male half of tail light wiring harness to tow vehicle electrical system to match diagram below:

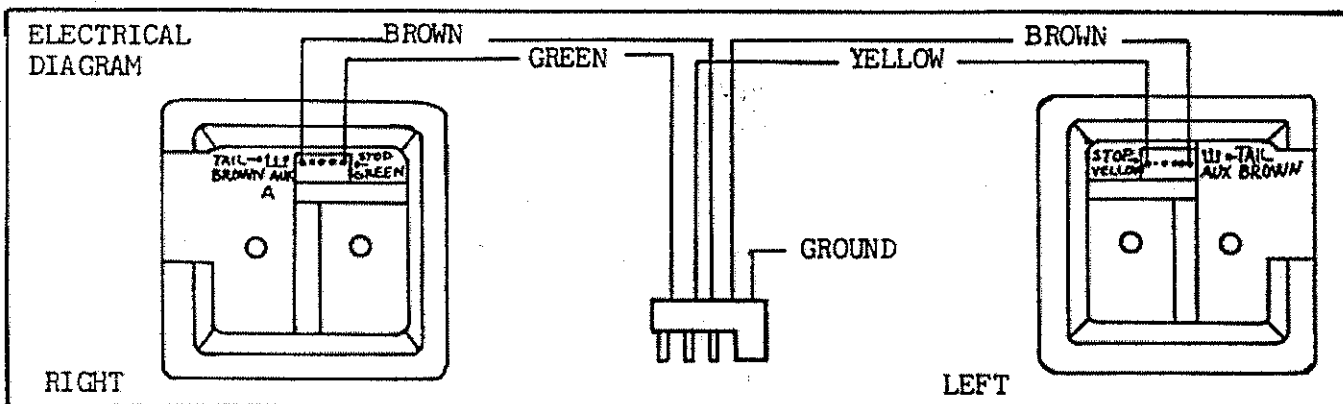

NOTE – Always check tail light, brake light, and turn signal operation each time sweeper is connected to towing vehicle.

NOTE – A tail light convertor module may be required to connect the sweeper lighting system to newer tow vehicles--order SWEEPSTER part number 07-1842 tail light convertor if necessary.

Installation

Mounting Brush Head

1. Position main frame assembly on a level area.
2. Turn key switch to "ON" position on control box.
3. Position engine and swing assembly in straight ahead position using "SWING" switch on control box.
4. Turn key switch to "OFF" position.
5. Slide brush head assembly under main frame, with cross tube of brush assembly to back, next to engine and swing assembly.
6. Raise back brush head cross tube until pivot tube plate on brush head lines up with swing assembly. Adjust brush head until square with front of swing frame and tighten bolts.
7. Pin the lift cylinder to the center ear on the brush head.
8. Connect spring on spring-chain assembly to right side ear next to lift cylinder. Run chain through notched hole in back plate of engine mounting frame.
9. Adjust brush pattern (brush contact) according to instructions in ADJUSTMENTS section of manual.
10. Install drive shaft between brush head input shaft and engine output shaft; tighten set screws securely. Install safety shield (if removed) to cover brush head input shaft.

Monarch Swing Lift

1. Add Dextron ATF (Automatic Transmission Fluid) as required to fill reservoir until fluid runs out filler elbow.

NOTE – Use ATF only in the Monarch Swing-Lift system

Operation

General Information

This unit is a power sweeper, not a bulldozer! Do not try to push materials as you would with a blade. For heavy material, reduce forward speed and make two or more passes, or remove heavy material first with a blade or bucket-loader.

Angle brush head fully left or right to sweep. Damage to sweeper or brush may occur if brush head is not angled fully left or right.

Required brush speeds will vary depending on sweeping conditions. For light sand, light gravel, or light snow, use slow brush speed. For heavy rock, mud, or other heavy material, a fast brush speed may be required.



CAUTION – Be aware of debris discharged by brush. Serious injury or property damage may result from flying debris.

Controls

In-cab controls located on electric control box:

1. Engine Stop Start
2. Brush Angle
3. Brush Lift
4. Sprinkler On-Off (Optional)

Engine Mounted Controls:

1. Throttle
2. Choke
3. Manual Clutch (Sweeper on-off)

Sweeping Conditions

When sweeping dusty material, sweep on a damp morning or on a day after it has rained when possible. Use the sprinkler system (optional) to help control dust.

NOTE – Optional sprinkler systems can be field installed on most sweepers equipped with Wisconsin engines.

Brush Speed

Always use the slowest speed that will do the job. Slower brush speeds will reduce flying debris and dust, and extends brush life under most conditions.

If excessive material is thrown forward toward tow vehicle, reduce brush speed.

Brush speed is controlled by engine speed with the throttle control on the engine. Increase engine speed to increase brush speed. Decrease engine speed to decrease brush speed.

Adjustment

Leveling Main Frame

2 Wheel Sweepers Only

Adjust hitch height up or down as required to level top of main frame front-to-rear. Hitch mounting bolts must be tight and secured with lock washers.

IMPORTANT – Use only grade 8 bolts, washers, and nuts for replacement in hitch.

Support Yokes

NOTE – For serial numbers 75146 and up only. Sweepers with serial numbers below 75146 do not have adjustable support yokes.

Adjust support yokes as follows:

1. Loosen two 5/8 carriage bolts in each support yoke (see figure 1).

2. Swing brush head assembly fully to the right.
3. Snug right support yoke around brush head tube and tighten two 5/8 bolts.
4. Swing brush head assembly fully to left.
5. Snug left support yoke around brush head tube and tighten two 5/8 bolts.
6. Brush tube should fit snugly into support yokes when fully angled left or right.
7. Level brush head per instructions on page 16.

NOTE – Adjust support yokes up or down if brush head will not level per instructions on page 16.

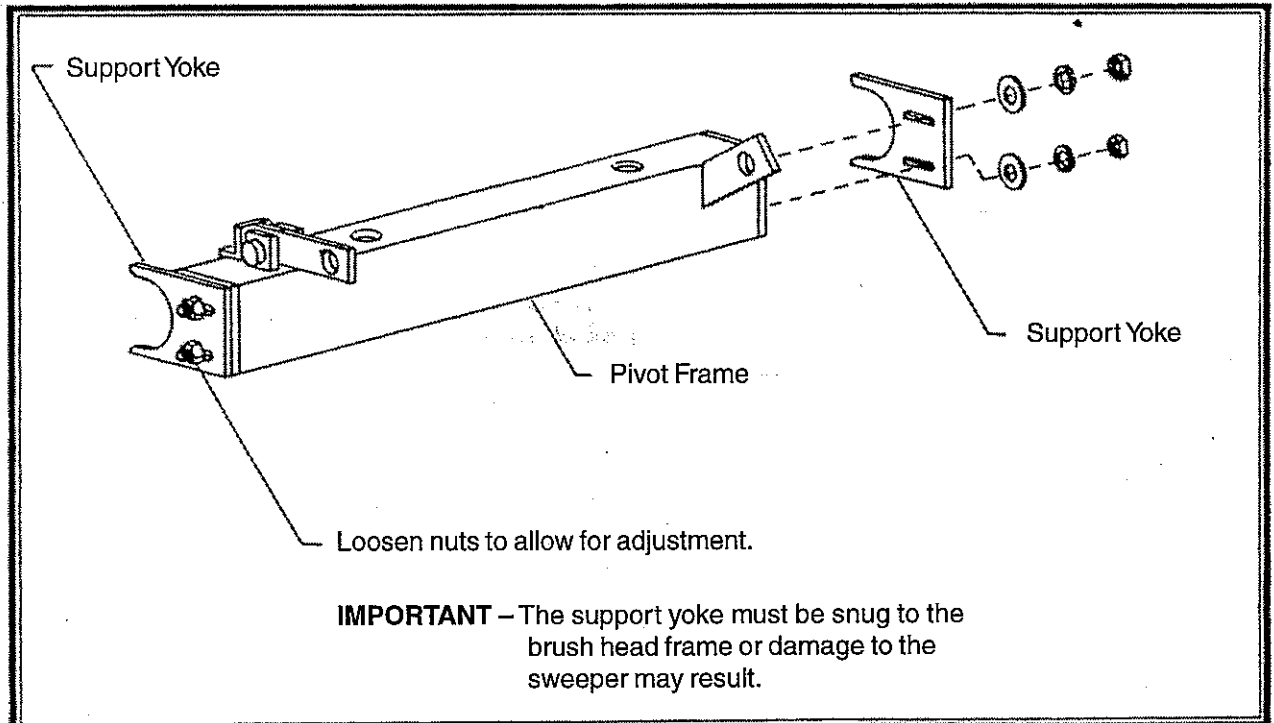

figure 1

Adjustment

Leveling Brush Head



CAUTION – Stop engine and remove key before making any adjustments to the sweeper.

Brush pattern (brush contact) should be the same all across the brush, with the brush fully right or fully left. Check leveling of brush daily and when brush is replaced.

NOTE – On 2-wheel sweepers only, be sure hitch is properly adjusted and main frame is level front-to-rear before making this adjustment (see Adjustment, Leveling Main Frame, page 15).

NOTE – Adjust support yokes before making this adjustment (see Adjustment, Support Yokes, page 15).

NOTE – Park and secure sweeper on a level surface before leveling brush head.

NOTE – Refer to figures 2, 3, 4, 5, and 6 while leveling brush head.

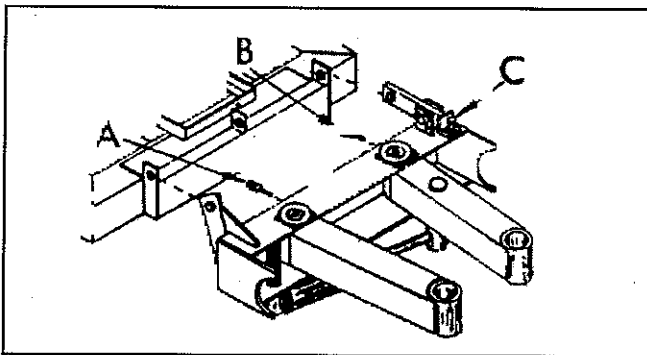

figure 2

1. Angle brush head to straight ahead position.
2. Raise brush 3 to 4 inches off the ground with lift cylinder.
3. Level-up brush head mounting plate with front of engine mounting frame. Securely tighten all 5 bolts holding brush head to engine mounting plate.
4. Adjust bolt "C" until each end of brush frame is the same height off the ground.
5. Turn bolts "A" and "B" out until they support an equal amount of weight.

NOTE – In steps 6-8 turn bolts "A" and "B" an equal number of turns.

6. Angle brush head fully right. Measure distance from ground to bottom front corner of brush head frame side angle. Check this measurement on both right and left sides, record measurements.
7. Angle brush head and check same measurements as step 6. Record measurements.
8. Compare measurements from steps 6 and 7 with figures 3, 4, 5, and 6. Adjust leveling as required.
9. Repeat steps 6-8 as required to level brush head.

Note – See Adjustment, Examples Of Leveling Brush Head, Page 17.

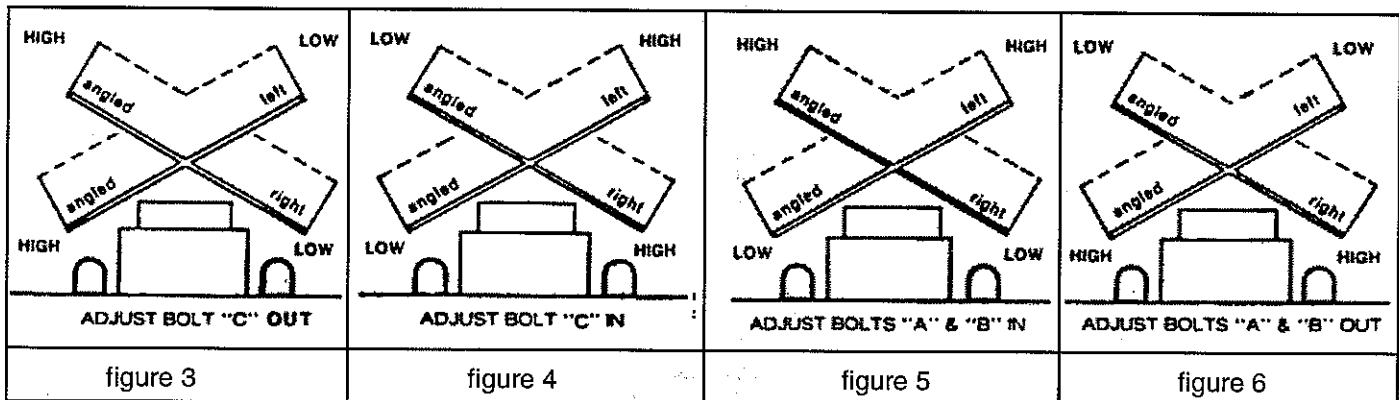

Adjustment

Examples of Leveling Brush Head

Example 1

See figure 7. Also figures 2,3,4,5,and 6 on page 16.

Angled fully right, left side of brush head frame side angle was $19\frac{1}{2}''$ and right side was $18''$. Then angled fully left, left side was $19\frac{1}{4}''$ and right side was $20''$. Per figure 5, adjust bolts "A" and "B" in.

Always turn bolts "A" and "B" equally, each time. $\frac{1}{2}$ turn is approximately $\frac{1}{8}''$ in measurement on brush head frame side. Recheck measurements and repeat adjustments per examples 1 or 2 as required.

Example 2

See figure 8. Also figures 2,3, 4, 5, and 6 on page 16.

Angled fully right, left side of brush head frame side angle was $19\frac{1}{2}''$ and right side was $21''$. Then angled fully left, left side was $19\frac{1}{2}''$ and right side was $20\frac{1}{2}''$. Per figure 4, adjust bolt "C" in.

Recheck measurements and repeat adjustments per example 1 or 2 as necessary.

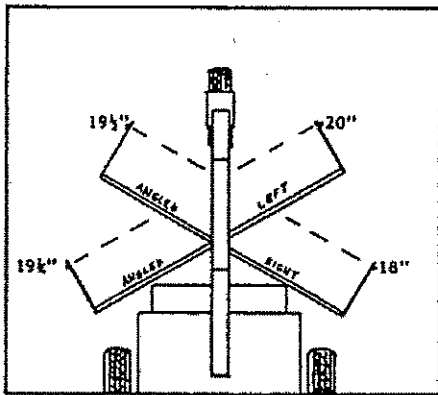

figure 7

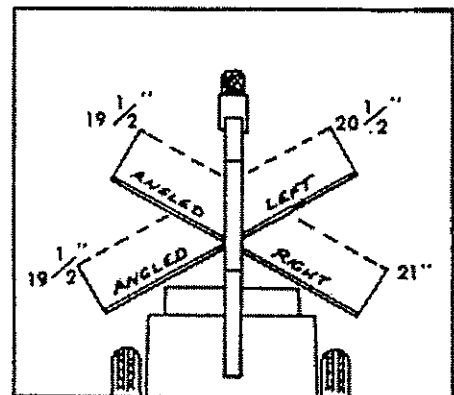

figure 8

Adjustment

Brush Pattern

Brush pattern (brush contact) is the front-to-rear distance cleaned on the ground when brush is running and sweeper is standing still. See figure 9.

Adjust brush pattern with spring-chain assembly (located under engine):

To increase brush pattern, lengthen chain.

To decrease brush pattern, shorten chain.

As brush wears, lengthen chain to maintain correct brush pattern.

Brush pattern must be the same width at both ends to prevent brush from wearing cone shaped. If brush pattern is not the same at both ends (with a new brush installed), level the brush head per instructions on page 16.

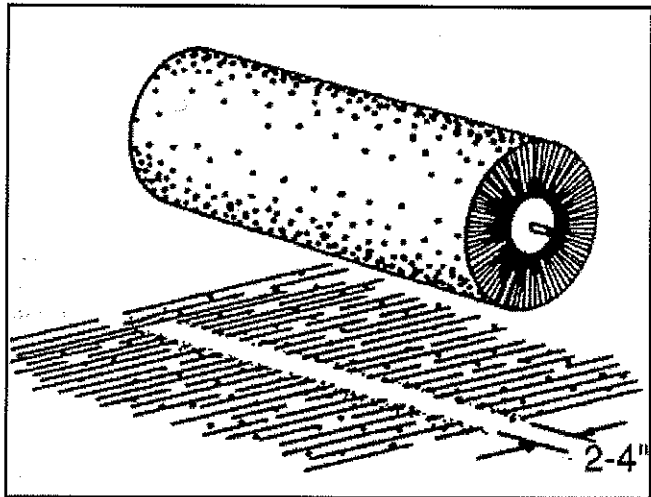

figure 9

Checking Brush Pattern

1. Move sweeper onto a level surface covered with sand or light gravel.
2. Start sweeper and set brush to a medium speed.
3. Lower brush onto sweeping surface. Run brush in place for 5 to 10 seconds in lowered position. Raise brush.
4. Move sweeper away and inspect clean area left by rotating brush. There should be an even strip 2 to 4 inches wide. If brush pattern is not even or is too wide or narrow adjust as follows:
 - A. Brush pattern even, but too narrow: Lengthen chain on spring chain assembly.
 - B. Brush pattern even, but too wide: Shorten chain on spring chain assembly.
 - C. Brush pattern not even (wider at one end than the other): Level brush per instructions on page 16.

Spring-Chain Assembly

Spring-chain assembly is located next to brush head lift cylinder.



CAUTION – Stop engine and remove key before adjusting spring-chain assembly.

For Sweeping

1. Adjust the spring-chain assembly so the tips of the bristles just touch the ground for maximum brush life.
2. For more effective sweeping, adjust spring-chain assembly so brush sweeps a 2 to 4 inch front-to-rear strip (see Adjustment, Brush Pattern).
3. In heavy sweeping, brush may tend to pull itself down, causing excessive brush wear. Adjust transport chain to limit the amount of spring stretch to give a 2 to 4 inch front-to-rear strip (see Adjustment, Brush Pattern).

Adjustment

Transport Chain

Transport chain is located next to brush head lift cylinder. Transport chain should be used when brush is in storage or moving between job sites.



CAUTION – Brush head weight could damage lift cylinder during transport, if transport chain is not used.



CAUTION – Stop engine and remove key before adjusting transport chain.

For Transport or Storage

1. Raise brush head assembly with lift cylinder. Stop engine.
2. Pull transport chain tight and place in chain holder.
3. Lower brush head assembly so weight is supported by transport chain.

For Sweeping

1. Adjust spring-chain assembly so brush bristles just touch the ground (see Adjustment, Spring-Chain Assembly page 18).
2. Adjust transport chain so spring stretches no more than 2 1/2 inches when brush is engaged and operating.

Maintenance

Brush Section Replacement

Position sweeper on a level surface. Place blocks in front and behind tires to prevent sweeper from rolling or secure hitch and set brakes on tow vehicle.

1. Connect transport chain so brush bristles are about 2 to 3 inches off the ground.
2. Remove lock collars from the bearing assemblies by removing set screws and tapping lock collars in direction opposite normal shaft rotation.
3. Remove the four bolts holding each core bearing, remove the drive chain, and remove the core (and old brush) from the brush head.
4. Stand brush assembly up on end with blocks under bottom end (sprocket end should be down).
5. Remove bolts from end ring and remove ring.
6. Remove old sections from core.
7. Fill core with new sections (per instructions included with new sections).
8. Reinstall end ring with bolts.
9. Reinstall core with new sections back into brush frame and reinstall drive chain.
10. Slide core side-to-side to align sprockets and pull forward on core to tighten drive chain; tighten bearing bolts.

NOTE – Core shaft must be equal distance on each end, from rear brush head frame to insure that drive sprockets are aligned.

11. Tighten lock collars by tapping into direction of shaft rotation; then tighten set screws.
12. Level brush head per Adjustment, Leveling Brush Head, page 16.
13. Adjust brush pattern per Adjustment, Brush Pattern, page 18.

Tightening Drive Chain

1. Loosen four bolts holding core bearings on brush shaft.
2. Pull brush forward to tighten chain.
3. Tighten bearing bolts.

Sprocket Alignment

1. Remove lock collars by removing set screws and tapping lock collar in direction opposite brush rotation.
2. Slide core side-to-side until sprockets align.
3. Reinstall lock collars by rotating lock collar into the direction of brush rotation; tighten set screws.

Hydraulic Swing-Lift Unit

A Monarch brand electric-hydraulic power unit provides hydraulic power for lifting and angling brush head assembly.

Refer to the separate Monarch manual (enclosed with this manual) for maintenance, service and troubleshooting of the Monarch power unit.

Maintenance

Lubrication

Axles Front and Rear

Axles are prelubricated at the factory. Check and/or repack axle bearings and hubs as required with high temperature wheel bearing grease.

Grease Zerks

Grease all grease fittings shown in figures 10-13, daily with Multi-purpose grease.

Drive Shaft

Grease u-joint on each end of drive shaft with multi-purpose lithium based grease daily

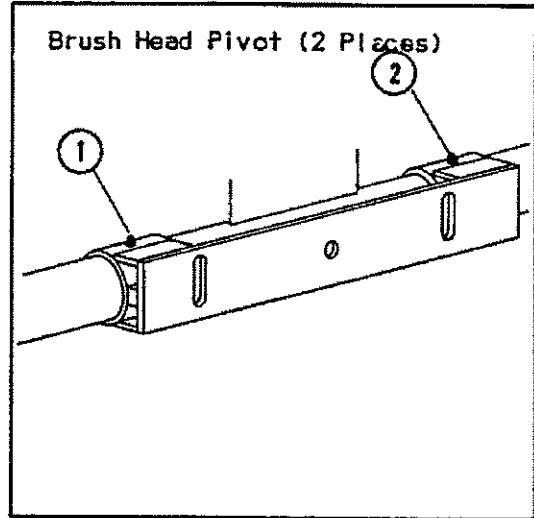

figure 10

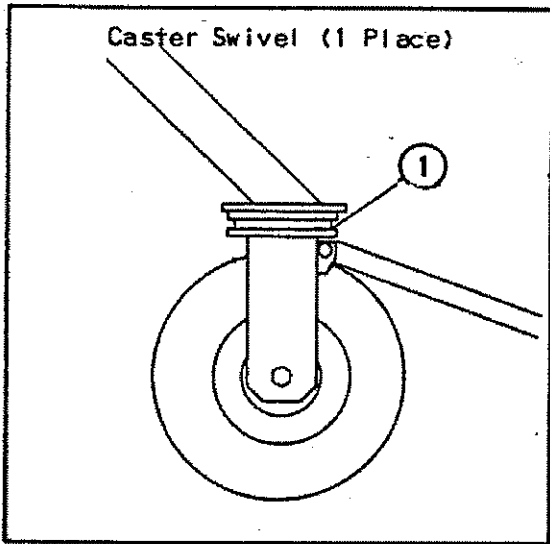

figure 13

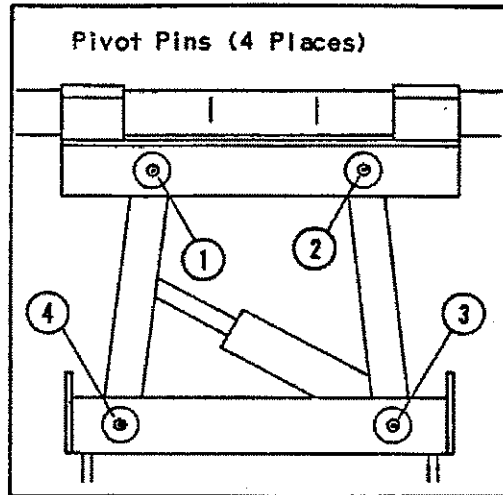

figure 11

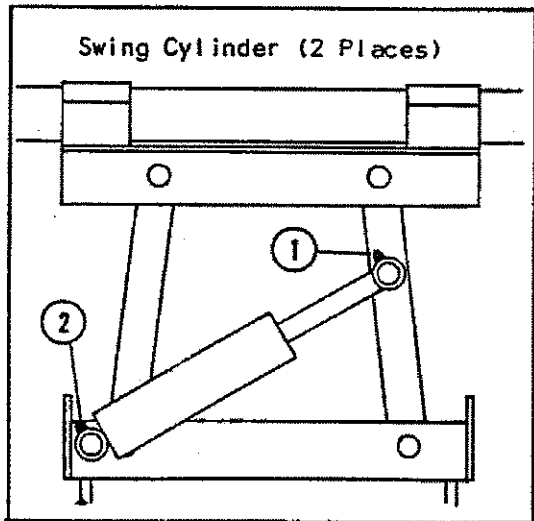

figure 12

Maintenance

Maintenance Schedule

	Daily	Weekly 50 hrs	See Engine Manual
Check Hydraulic Oil Level (Monarch Unit)	●		
Lubricate All Grease Zerk	●		
Check Brush Pattern	●		
Check Lights for Proper Operation	●		
Level Brush Head Assembly	●		
Inspect Hitch and Hitch Hardware	●		
Inspect Hitch Safety Chains	●		
Clean Safety Decals (Replace if necessary)	●		
Clean Optional Sprinkler System Filter		●	
Check Battery Electrolyte Level		●	
Check Tire Air Pressure		●	
Tighten Bolts and Hardware		●	
Check and Tighten Hydraulic Fittings and Hoses		●	
Check Engine Crankcase Oil Level			●
Clean or Replace Air Cleaner			●
Change Engine Crankcase Oil			●
Clean Engine Fuel Sediment Bowl or Replace Fuel Filter			●

Notes

1. The first part of the document discusses the importance of maintaining accurate records of all transactions. This is essential for ensuring the integrity of the financial statements and for providing a clear audit trail.

2. It is also important to ensure that all transactions are recorded in a timely and accurate manner. This helps to prevent errors and discrepancies in the financial data.

3. The second part of the document focuses on the importance of maintaining accurate records of all assets and liabilities. This is essential for ensuring the accuracy of the balance sheet and for providing a clear picture of the company's financial position.

4. It is also important to ensure that all assets and liabilities are recorded in a timely and accurate manner. This helps to prevent errors and discrepancies in the financial data.

5. The third part of the document discusses the importance of maintaining accurate records of all income and expenses. This is essential for ensuring the accuracy of the income statement and for providing a clear picture of the company's profitability.

6. It is also important to ensure that all income and expenses are recorded in a timely and accurate manner. This helps to prevent errors and discrepancies in the financial data.

7. The fourth part of the document focuses on the importance of maintaining accurate records of all cash flows. This is essential for ensuring the accuracy of the cash flow statement and for providing a clear picture of the company's liquidity.

8. It is also important to ensure that all cash flows are recorded in a timely and accurate manner. This helps to prevent errors and discrepancies in the financial data.

9. The fifth part of the document discusses the importance of maintaining accurate records of all taxes. This is essential for ensuring the accuracy of the tax return and for providing a clear picture of the company's tax liability.

10. It is also important to ensure that all taxes are recorded in a timely and accurate manner. This helps to prevent errors and discrepancies in the financial data.

Carrier Assembly (3 and 4 Wheel)

Ref	Part	Qty	Description
1.	03-0045	3	Fitting, Elbow, HP, 90°, 1/4MP, 1/4FPS
2.	03-0371	1	System, Hydraulic, Monarch, 12Volt
3.	03-3983	4	Assembly, Parklamp, 1/2 Hose, W/Clamp
4.	07-0018	3	Screw, Cap, 3/8-16 x 1
5.	07-0144	10	Nut, Lug, 1/2-20
6.	07-0819	1	Cable, Battery, 4 x 32, 3/8 Eye
7.	07-0820	1	Cable, Battery, 4 Gauge x 60
8.	07-0836	1	Terminal, Block, 12 Post
9.	07-0841	1	Wire, Cord, 16 Gauge
10.	07-0856	2	Nut, Lock, 1/2, F/Strain Relief
11.	07-0857	1	Strain, Relief, 1/2
12.	07-0871	1	Battery
13.	07-1093	8	Nut, Hex, 1/2-20
14.	07-1353	1	Axle, Assembly, Rear
15.	07-1427	1	Strain, Relief, 1/2, WHT
16.	07-1629	1	Box, Electric, Junction
17.	07-1718	4	Washer, Lock, Split, 3/8
18.	07-1757	1	Box, Battery, Plastic
19.	07-1762	8	Washer, Lock, Split, 1/2
20.	07-1763	8	Washer, Flat, 1/2
21.	07-5142	1	Cable, Battery, 4 x 27
22.	07-2480	2	Screw, Socket Head, 3/8-16 x 1/2
24.	07-3176	1	Cable, Battery, 4 x 20
25.	07-3279	3	Washer, Flat, 3/8
26.	07-3624	4	Tack, Metal, 31 Series
28.	07-3654	4	Nut, Hex, 3/8-16
30.	07-5158	4	U-Bolt, 1/2-20 x 5 1/2 x 2 7/16
33.	11-7129	1	Weld, Frame, Main, P, 3 or 4Wheel
34.	50-0004	1	Label, Plate, Serial Number
35.	07-5715	1	Boot, Red, #2/#8
36.	07-2022	2	Terminal, Ring, 3/8, 4 Gauge
37.	07-2171	7 ft	Cable, Battery, #4
38.	07-3273	2	Washer, Lock, Split, 5/16
39.	07-3278	2	Nut, Hex, 5/16-18
40.	07-5259	1	Extender, Battery, Bolt, 5/16-18
41.	07-1904	2	Screw, Round Head, Phillips, 8-32 x 3/4
42.	07-1906	2	Nut, Hex, 8-32
43.	07-1907	2	Washer, Lock, 8
44.	50-0574	1	Label, Warning, Read, Manual
45.	50-0186	2	Label, Logo, Sweepster
46.	50-0575	2	Label, Warning, Fenders
47.	50-0576	3	Label, Tie Down Point
A.	07-3640	4	Screw, Cap, 1/4-20 x 1 3/4

Carrier Assembly (3 and 4 Wheel)

Assembly No. 11-4244

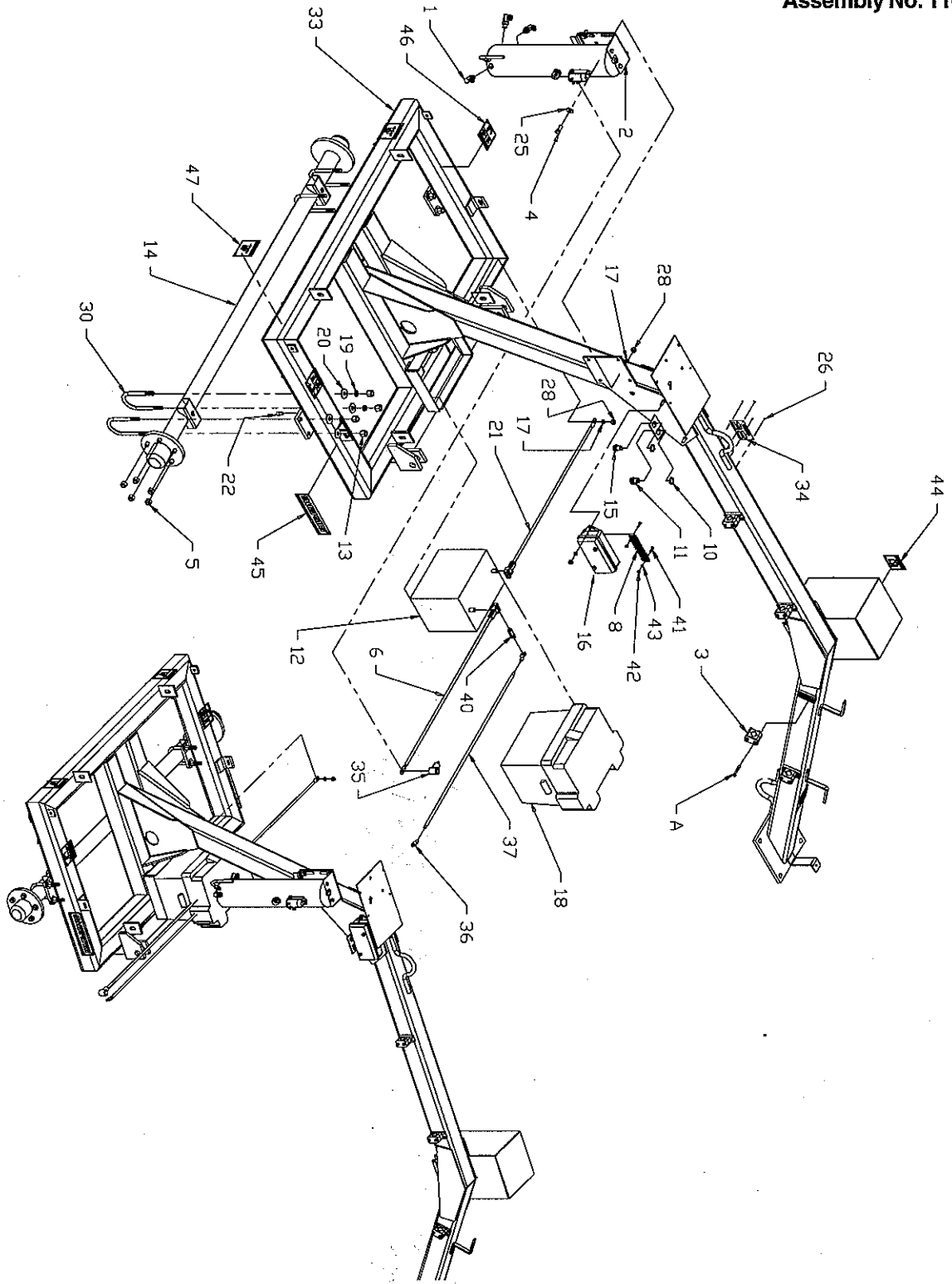

Caster (3 Wheel Assembly)

Assembly No. 11-4442

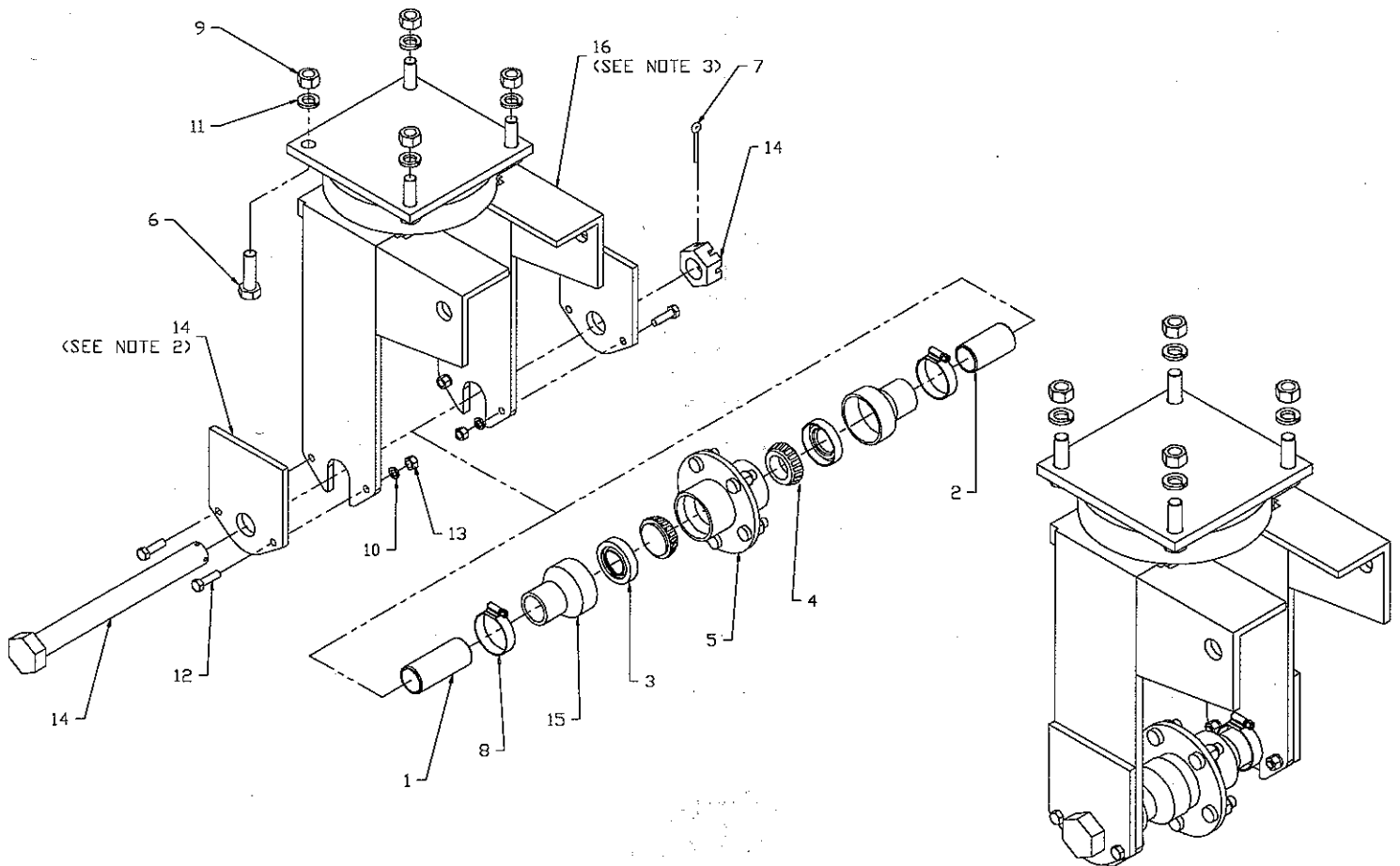

Ref Part Qty Description

Ref	Part	Qty	Description
1.	05-0534A	1	Spacer, 3 1/2, Caster
2.	05-0534B	1	Spacer, 2.70, Caster
3.	05-0535	2	Seal, Oil
4.	05-0536	2	Bearing
5.	05-0538	1	Hub, Caster, Tow, Front, W/Cups & Hardware
6.	07-0066	4	Screw, Cap, 5/8-11 x 2
7.	07-0206	1	Pin, Cotter, 3/16 x 2
8.	07-1188	2	Clamp, Screw, 1 5/16-2 1/4
9.	07-1294	4	Nut, Hex, 5/8-11
10.	07-1718	4	Washer, Lock, Split, 3/8
11.	07-1872	4	Washer, Lock, Split, 5/8
12.	07-2116	4	Screw, Cap, 3/8-16 x 1 1/4
13.	07-3654	4	Nut, Hex, 3/8-16
14.	07-4391	1	Kit, Mounting, F/Swivel, W/O Spacers
15.	09-0039	2	Shield, Dirt, Caster
16.	11-1539	1	Weld, Frame, Caster, Mounting, Single

Caster (4 Wheel Assembly)

Assembly No. 11-4416

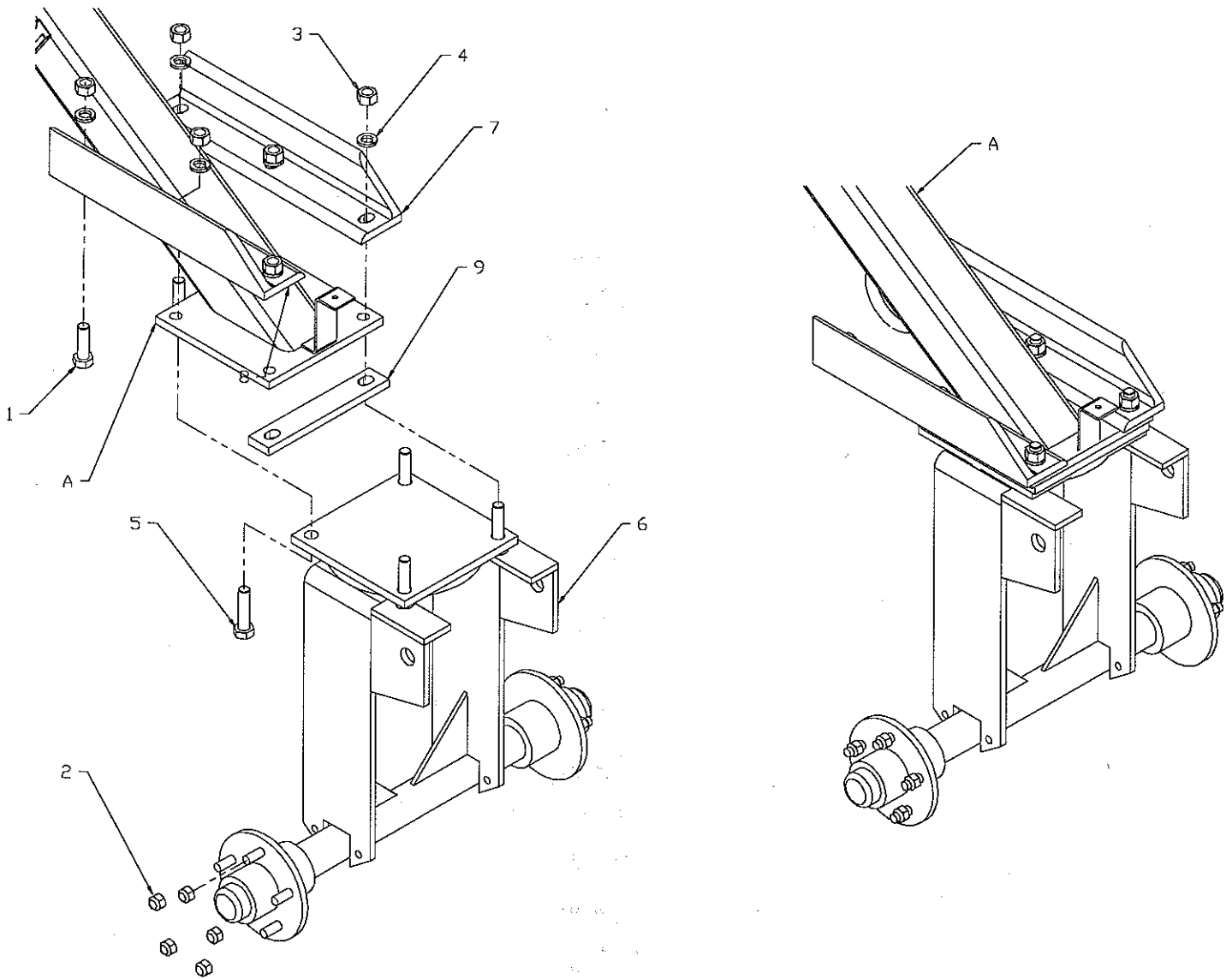

Ref	Part	Qty	Description
1.	07-0066	2	Screw, Cap, 5/8-11 x 2
2.	07-0144	10	Nut, Lug, 1/2-20
3.	07-1294	6	Nut, Hex, 5/8-11
4.	07-1872	6	Washer, Lock, Split, 5/8
5.	07-2855	4	Screw, Cap, 5/8-11 x 2 1/2
6.	11-1530	1	Weld, Mounting, Caster, Dual
7.	11-7222	1	Angle, Mounting, Caster, Left
8.	11-7223	1	Angle, Mounting, Caster, Right
9.	11-7224	1	Plate, Mounting, Caster, Dual

Carrier Assembly (2 Wheel)

Ref	Part	Qty	Description
1.	03-0045	3	Fitting, Elbow, HP, 90°, 1/4MP, 1/4FPS
2.	03-0371	1	System, Hydraulic, Monarch, 12Volt
3.	03-3983	3	Assembly, Parklamp, 1/2 Hose, W/Clamp
4.	07-0018	3	Screw, Cap, 3/8-16 x 1
5.	07-0144	10	Nut, Lug, 1/2-20
6.	07-0819	1	Cable, Battery, 4 x 32, 3/8 Eye/Standard
8.	07-0836	1	Terminal, Block, 12 Post
10.	07-0856	2	Nut, Lock, 1/2, F/Strain Relief
11.	07-0857	1	Strain, Relief, 1/2 BRN, 16/12
12.	07-0871	1	Battery, 24-3, 425CCA, 80 Reserve
13.	07-1093	8	Nut, Hex, 1/2-20
14.	07-1353	1	Axle, Assembly, Rear
15.	07-1427	1	Strain, Relief, 1/2
16.	07-1629	1	Box, Electric, Junction, Block
17.	07-1718	4	Washer, Lock, Split, 3/8
18.	07-1757	1	Box, Battery, Plastic
19.	07-1762	8	Washer, Lock, Split, 1/2
20.	07-1763	8	Washer, Flat, 1/2
21.	07-5142	1	Cable, Battery, 4 x 27, 3/8 Eye & Post
22.	07-2480	2	Screw, Socket Head, 3/8-16 x 1/2
25.	07-3279	3	Washer, Flat, 3/8
26.	07-3624	4	Tack, Metal
28.	07-3654	4	Nut, Hex, 3/8-16
30.	07-5158	4	U-Bolt, 1/2-20 x 5 1/2 x 2 7/16
33.	11-2573	1	Weld, Frame, Main, 2 Wheel
34.	50-0004	1	Label, Plate, Serial, Number
35.	07-5715	1	Boot, Red, #2/#8
36.	07-2022	2	Terminal, Ring, 3/8
37.	07-2171	7 ft	Cable, Battery
38.	07-3273	2	Washer, Lock, Split, 5/16
39.	07-3278	2	Nut, Hex, 5/16-18
40.	07-5259	1	Extender, Battery, Bolt, 5/16-18
41.	07-1904	2	Screw, Round Head, Phillips, 8-32 x 3/4
42.	07-1906	2	Nut, Hex, 8-32
43.	07-1907	2	Washer, Lock, 8
44.	50-0574	1	Label, Warning, Read Manual
45.	50-0186	2	Label, Logo, Sweepster
46.	50-0575	2	Label, Warning, Fenders
47.	50-0576	3	Label, Tie Down Point
48.	13-11807	1	Plate, Mounting, Cable, Bracket
49.	07-1477	1	Strain, Relief, 3/4, Water Tight
50.	07-2245	1	Strain, Relief Nut, 3/4

Carrier Assembly (2 Wheel)

Assembly No. 11-4198

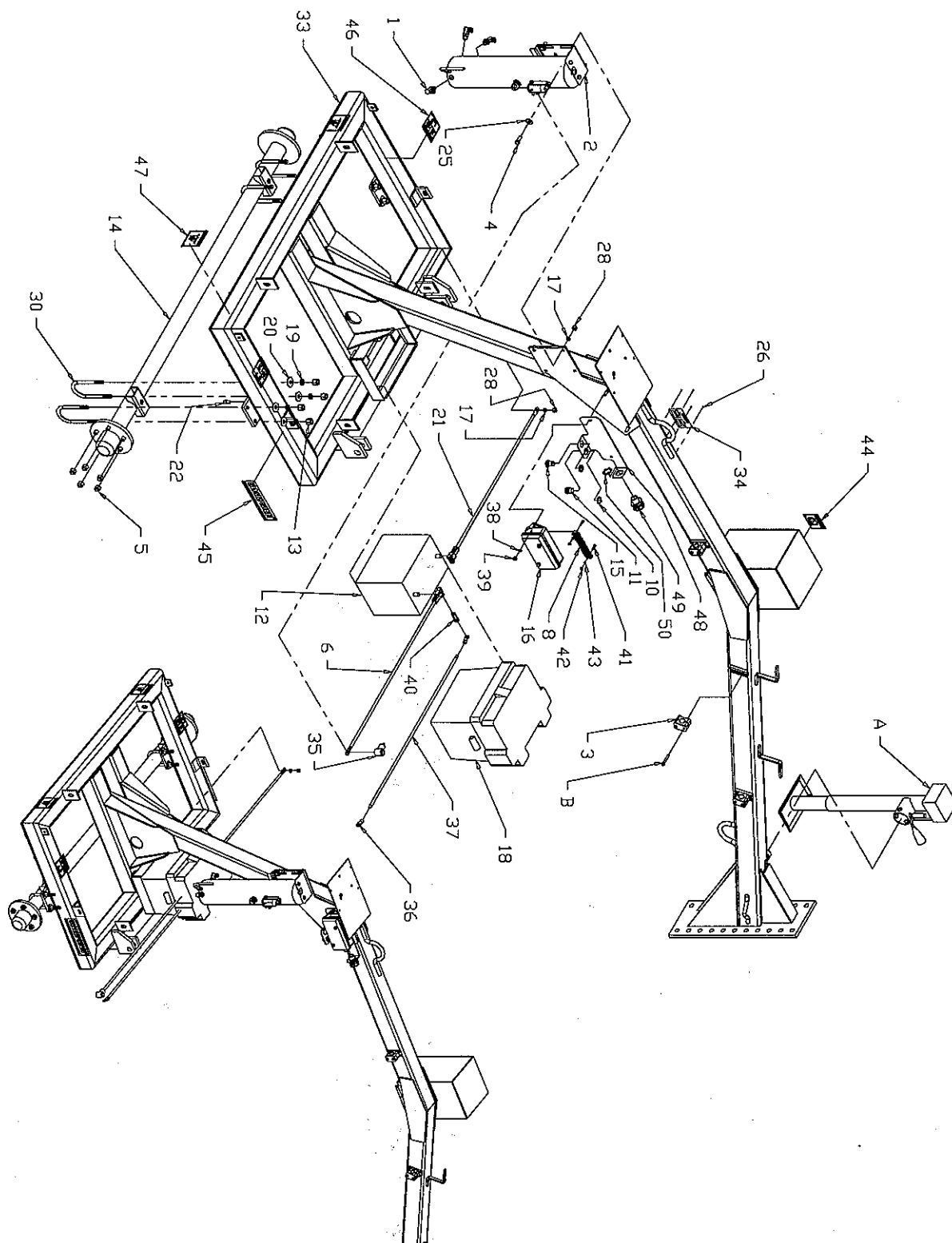

Hitch Assembly

Assembly No. 28-1512
(2 Wheel 2" Ball)

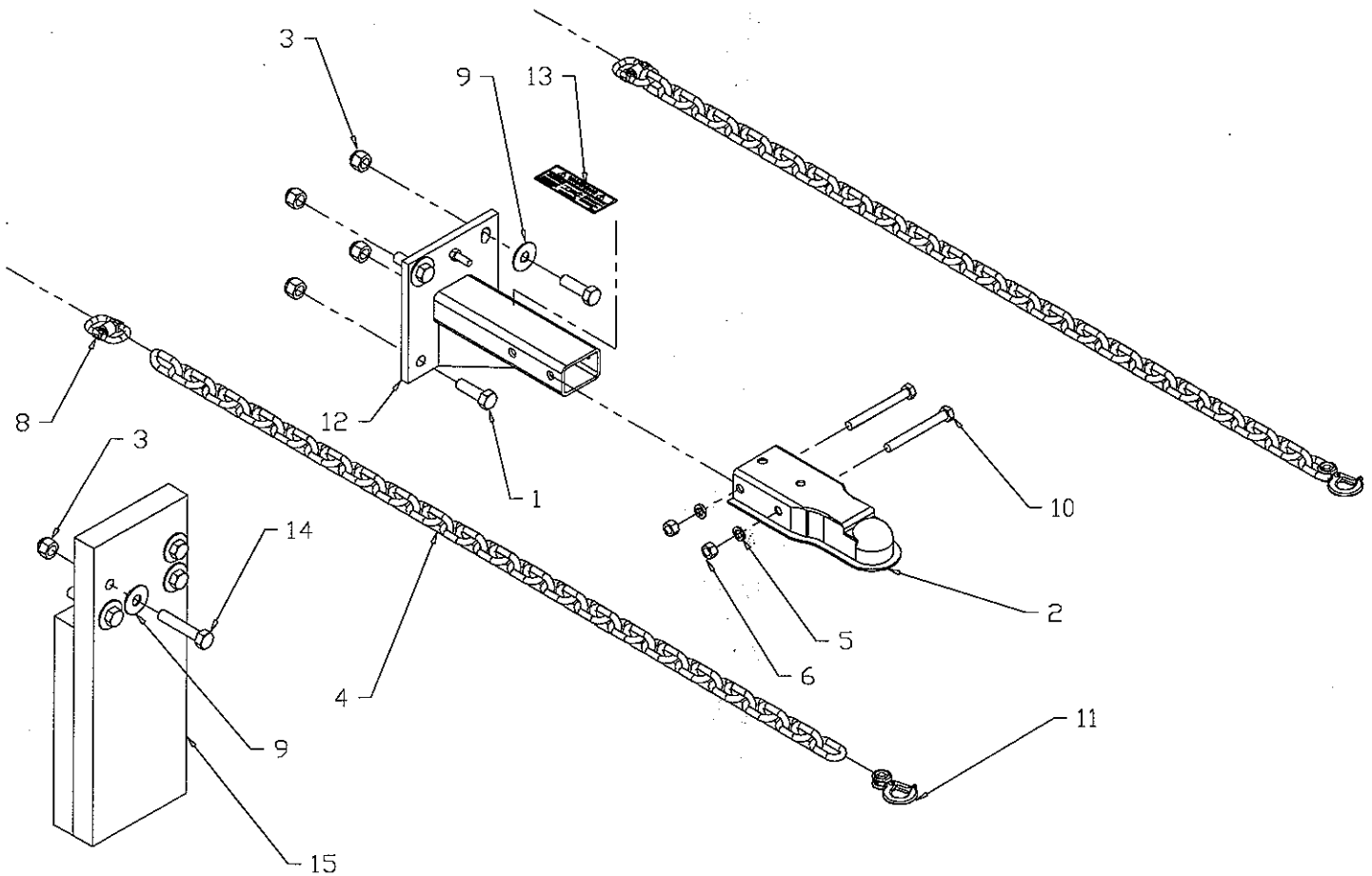

Ref	Part	Qty	Description
1.	07-5169	4	Screw, Cap, M16-2 x 50
2.	07-0363	1	Hitch, Ball, 2
3.	07-4532	8	Nut, Hex, Lock, M16-2
4.	07-1604	2	Chain, 3/8, 40 Links
5.	07-1762	2	Washer, Lock, Split, 1/2
6.	07-1764	2	Nut, Hex, 1/2-13
8.	07-2032	2	Clevis, Double Link, 9/32
9.	07-5172	6	Washer, Flat, M16
10.	07-3675	2	Screw, Cap, 1/2-13 x 4 1/2
11.	07-4815	2	Hook, Split, W/3/8 Clevis & Latch, F/Safety Chains
12.	11-6872	1	Weld, Mounting, Hitch, F/Pintel/Ball Insert
13.	50-0042	1	Label, Warning, Hitch
14.	07-5170	4	Screw, Cap, M16-2 x 80
15.	10-0278	1	Stand, Tow Behinds

Hitch Assembly

Assembly No. 28-1509
(2 Wheel 3" Pintle)

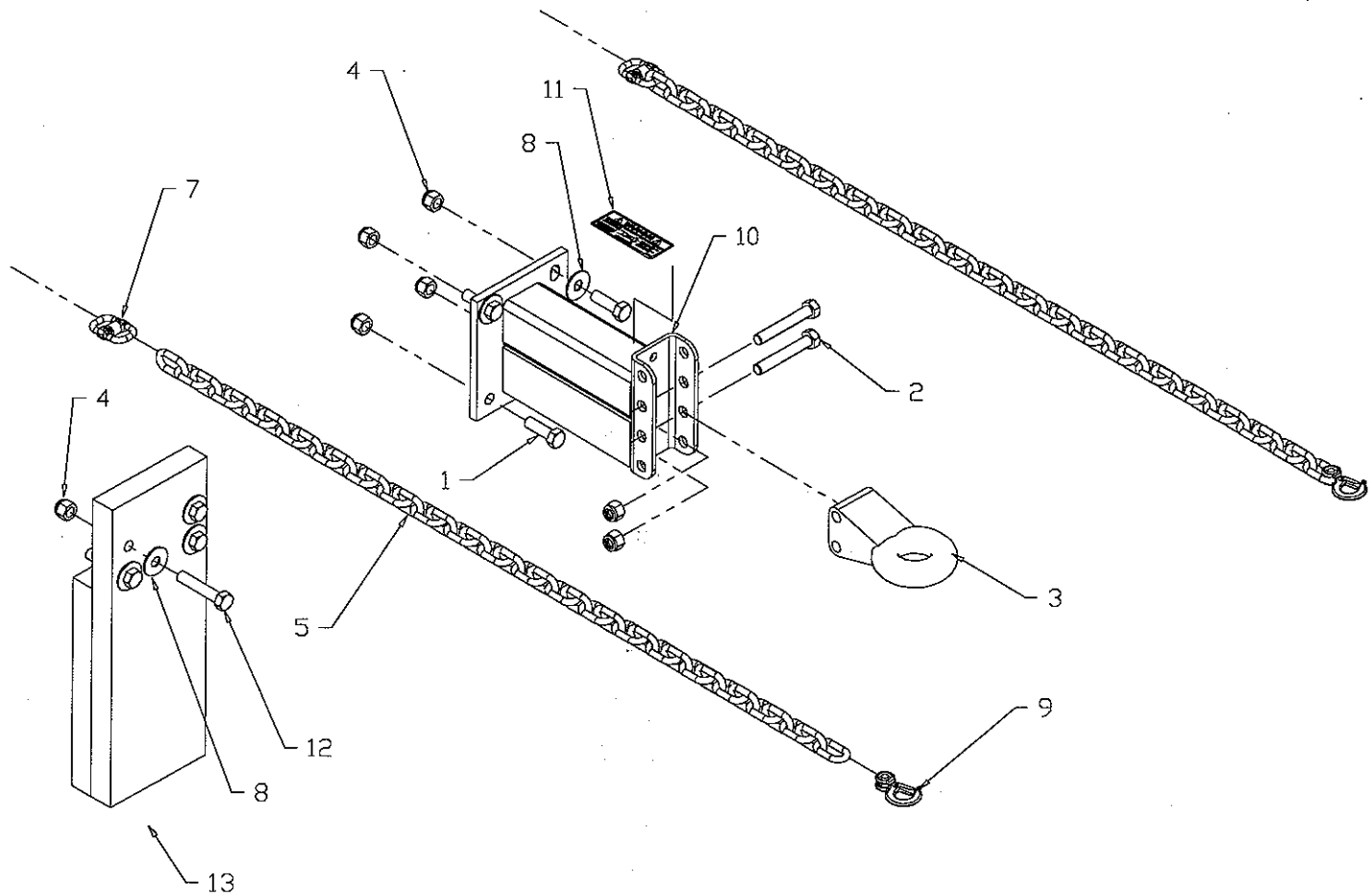

Ref	Part	Qty	Description
1.	07-5169	4	Screw, Cap, M16-2x50mm
2.	07-5173	2	Screw, Cap, M16-2 x 120mm
3.	07-1035	1	Eye, Pintle, 3, Bolt-On
4.	07-4532	10	Nut, Hex, Lock, M16-2
5.	07-1604	2	Chain, 3/8, 40 Links
7.	07-2032	2	Clevis, Double Link, 9/32
8.	07-5172	6	Washer, Flat, M16
9.	07-4815	2	Hook, Split, W/3/8 Clevis & Latch
10.	11-3016	1	Weld, Hitch, Mounting, F/Bolt-On Pintle
11.	50-0042	1	Label, Warning, Hitch
12.	07-5170	4	Screw, Cap, M16-2x80mm
13.	10-0278	1	Stand

Hitch Assembly

Assembly No. 28-1510
(2 Wheel 2" Pintle W/Chain)

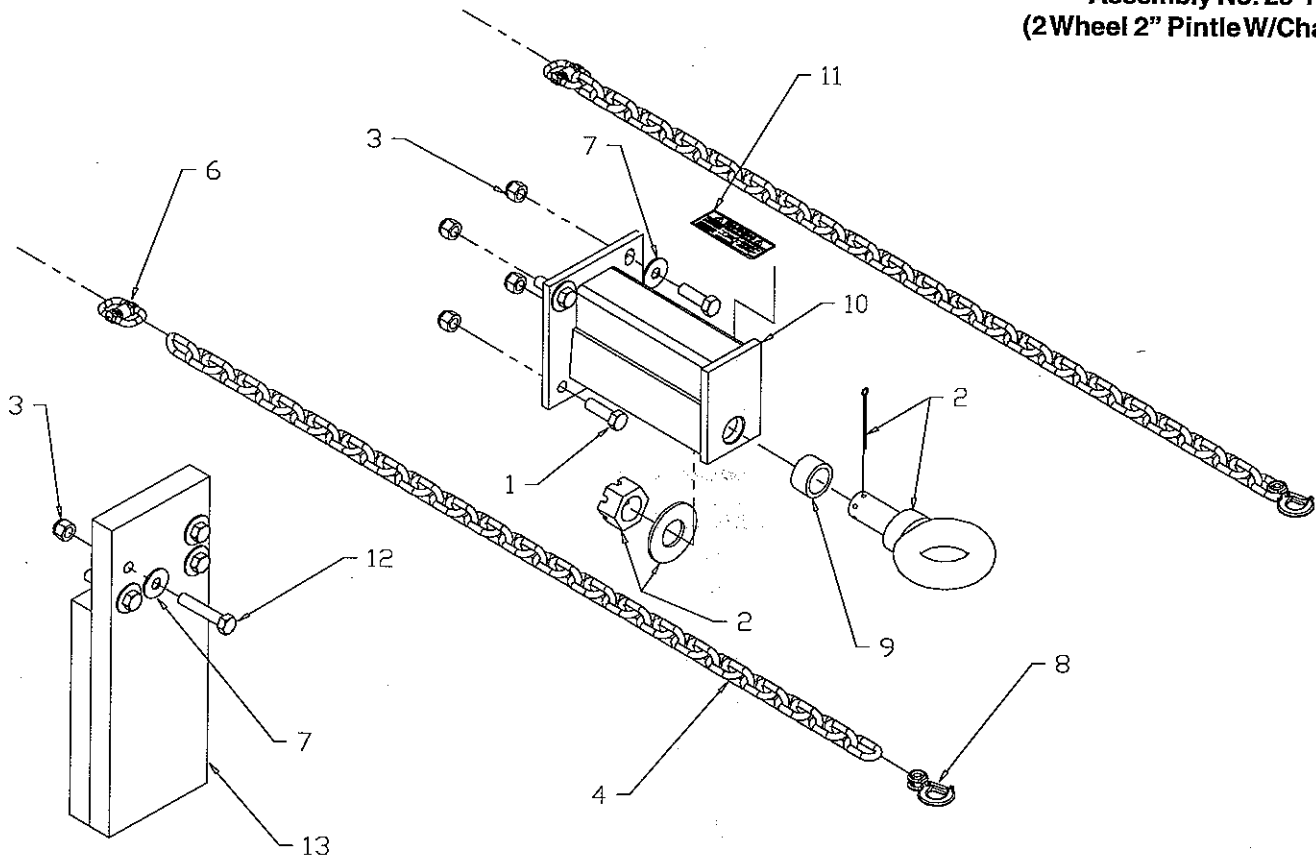

Ref	Part	Qty	Description
1.	07-5169	4	Screw, Cap, M16-2 x 50mm
2.	07-1027	1	Eye, Pintle, 2 1/2, I-Bolt
3.	07-4532	8	Nut, Hex, Lock, M16-2
4.	07-1604	2	Chain, 3/8, 40 Links
6.	07-2032	2	Clevis, Double Link, 9/32
7.	07-5172	6	Washer, Flat, M16
8.	07-4815	2	Hook, Split, W/3/8 Clevis & Latch
9.	13-1684	1	Bushing, 2 x 1.505 x 1.12
10.	13-2606	1	Weld, Mounting, Hitch, F/I-Bolt Pintle
11.	50-0042	1	Label, Warning, Hitch
12.	07-5170	4	Screw, Cap, M16-2 x 80mm
13.	10-0278	1	Stand

Hitch Assembly

Assembly No. 28-1513
(2 Wheel 2 5/16" Ball)

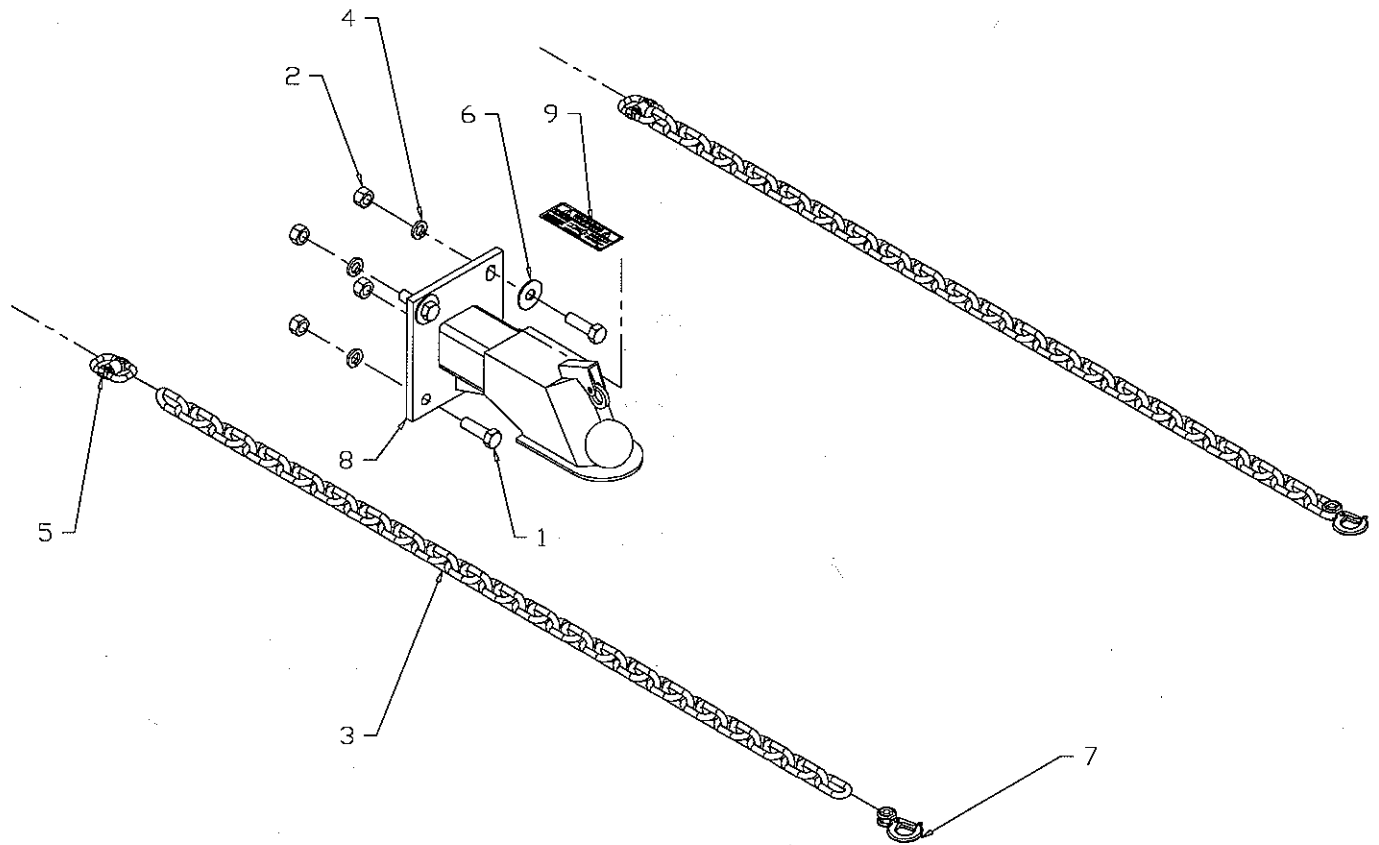

Ref	Part	Qty	Description
1.	07-0066	4	Screw, Cap, 5/8-11 x 2
2.	07-1294	4	Nut, Hex, 5/8-11
3.	07-1604	2	Chain, 3/8, 40 Links
4.	07-1872	4	Washer, Lock, Split, 5/8
5.	07-2032	2	Clevis, Double Link, 9/32
6.	07-3120	2	Washer, Flat, 5/8
7.	07-4815	2	Hook, Split, W/3/8 Clevis & Latch
8.	11-2877	1	Weld, Mounting, Hitch, Ball, 2 5/16
9.	50-0042	1	Label, Warning, Hitch

Hitch Assembly

Assembly No. 28-1504
(3 or 4 Wheel 2" Ball W/Pin)

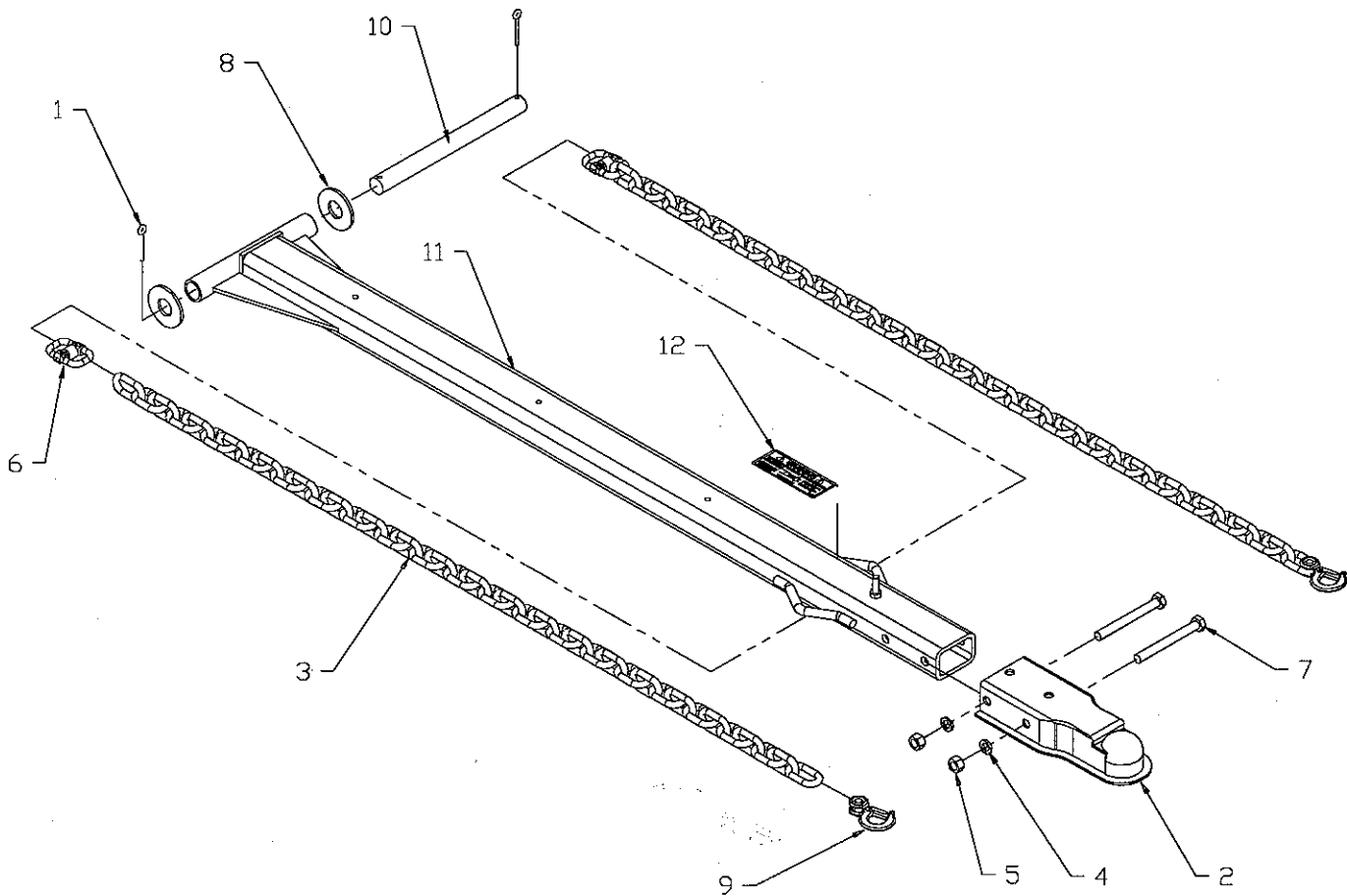

Ref	Part	Qty	Description
-----	------	-----	-------------

1.	07-0206	2	Pin, Cotter, 3/16 x 2
2.	07-0363	1	Hitch, Ball, 2
3.	07-1604	2	Chain, 3/8, 4o Links
4.	07-1762	2	Washer, Lock, Split, 1/2
5.	07-1764	2	Nut, Hex, 1/2-13
6.	07-2032	2	Clevis, Double Link, 9/32
7.	07-3675	2	Screw, Cap, 1/2-13 x 4 1/2
8.	07-4040	2	Washer, Flat, 1
9.	07-4815	2	Hook, Split, w/ 3/8 Clevis & Latch
10.	11-1511	1	Pin, Towing, Pole, Install
11.	11-1536	1	Weld, Hitch
12.	50-0042	1	Label, Warning, Hitch

Hitch Assembly

Assembly No. 28-1505
(3 or 4 Wheel Drawbar W/Pin)

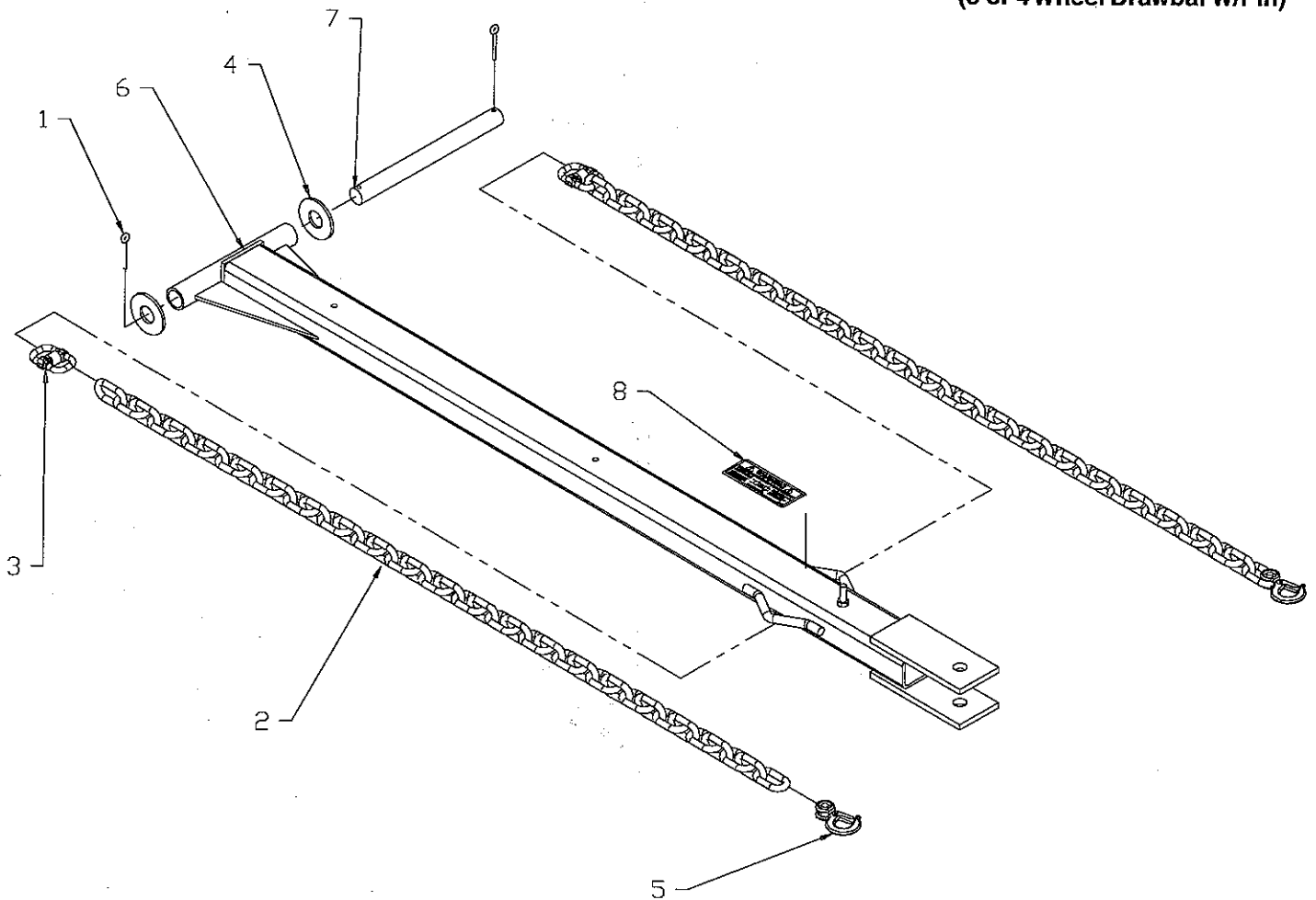

Ref	Part	Qty	Description
1.	07-0206	2	Pin, Cotter, 3/16 x 2
2.	07-1604	2	Chain, 3/8, 40 Links
3.	07-2032	2	Clevis, Double Link, 9/32
4.	07-4040	2	Washer, Flat, 1
5.	07-4815	2	Hook, Split, W/3/8 Clevis & Latch
6.	11-1509	1	Weld, Hitch, Towbar, Drop Pin
7.	11-1511	1	Pin, Towing Pole, Install
8.	50-0042	1	Label, Warning, Hitch

Hitch Assembly

Assembly No. 28-1506
(3 or 4 Wheel 2 5/16" W/Pin)

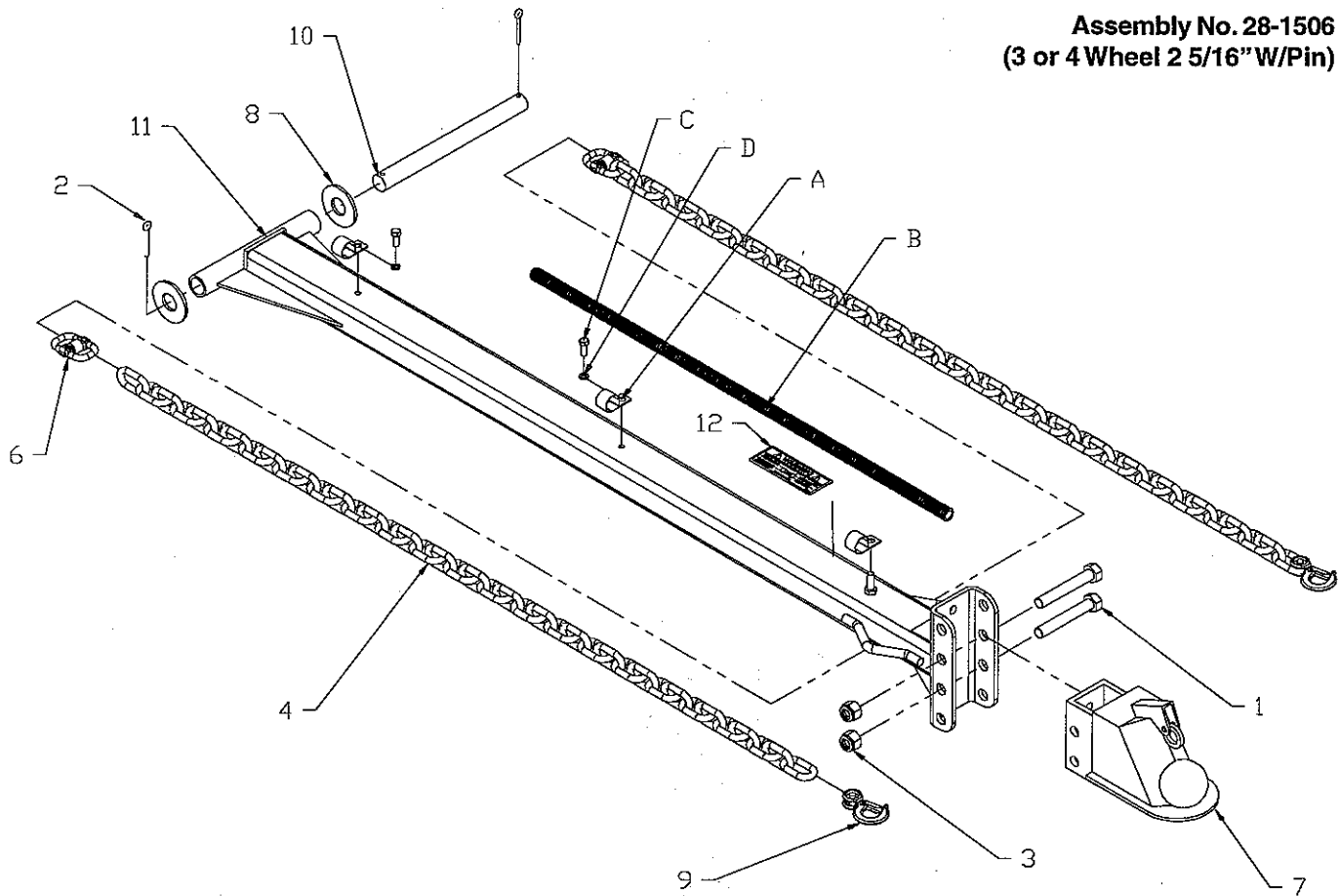

Ref	Part	Qty	Description
1.	07-5173	2	Screw, Cap, M16-2 x 120mm
2.	07-0206	2	Pin, Cotter, 3/16 x 2
3.	07-4532	2	Nut, Hex, Lock, M16-2
4.	07-1604	2	Chain, 3/8, 40 Links
6.	07-2032	2	Clevis, Double Link, 9/32
7.	07-2479	1	Hitch, Ball, 2 5/16
8.	07-4040	2	Washer, Flat, 1
9.	07-4815	2	Hook, Split, W/3/8 Clevis & Latch
10.	11-1511	1	Pin, Towing, Pole, Install
11.	13-0777	1	Weld, Hitch, Towbar, 3 or 4 Wheel
12.	50-0042	1	Label, Warning, Hitch
A.	07-1734	3	Clamp, Rubber, 1
B.	07-1833	8 ft	Loom, Flex, Guard, 3/4
C.	07-3426	2	Screw, Cap, 5/16-18 x 3/4
D.	07-3273	2	Washer, Lock, Split, 5/16

Hitch Assembly

Assembly No. 28-1508
(3 or 4 Wheel 3" Pintle)

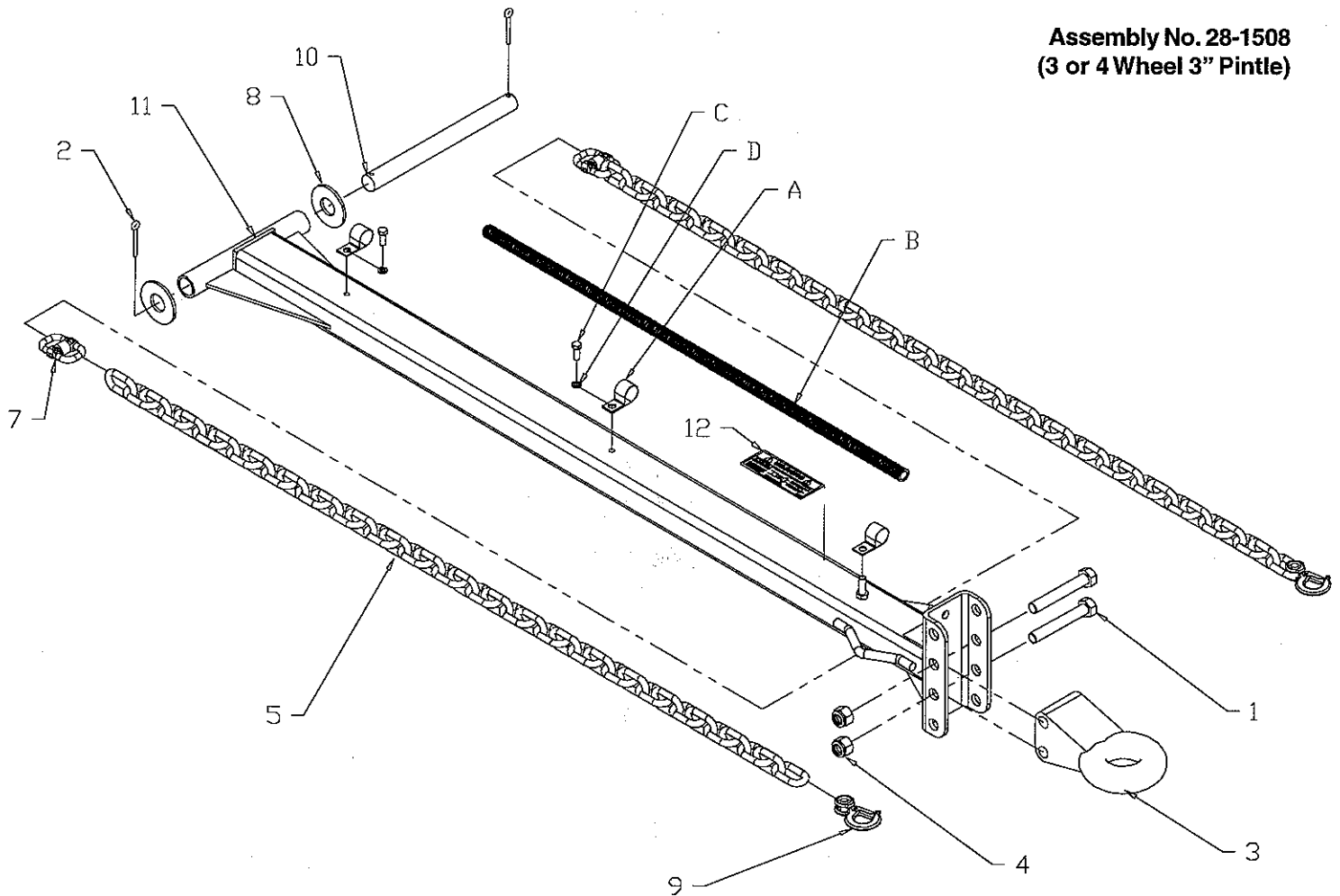

Ref	Part	Qty	Description
1.	07-5173	2	Screw, Cap, M16-2 x 120mm
2.	07-0206	2	Pin, Cotter, 3/16 x 2
3.	07-1035	1	Eye, Pintel, 3, Bolt-On
4.	07-4532	2	Nut, Hex, Lock, M16-2
5.	07-1604	2	Chain, 3/8, 40 Links
7.	07-2032	2	Clevis, Double Link, 9/32
8.	07-4040	2	Washer, Flat, 1
9.	07-4815	2	Hook, Split, W/3/8 Clevis & Latch
10.	11-1511	1	Pin, Towing Pole, Install
11.	13-0777	1	Weld, Hitch, Towbar, 3 or 4 Wheel
12.	50-0042	1	Label, Warning, Hitch
A.	07-1734	3	Clamp, Rubber, 1
B.	07-1833	8 ft	Loom, Flex, Guard, 3/4
C.	07-3426	2	Screw, Cap, 5/16-18 x 3/4
D.	07-3273	2	Washer, Lock, Split, 5/16

Brush Head Assembly

Ref	Part	Qty	Description	Ref	Part	Qty	Description
1.	05-0543	1	Shaft, Telescoping, P84, 1 1/4 RD, 7/8 Hex	30.	07-3654	9	Nut, Hex, 3/8-16
2.	06-0086	1	Chain, 60 x 88, W/Master	31.	07-3679	1	Screw, Cap, 5/8-11 x 1 3/4
3.	06-0180	1	Sprocket, 60B11, 7/8Hex, 5/16 Set Screw	32.	07-3709	3	Bolt, Carriage, 1/2-13 x 1 3/4
4.	06-0208	1	Sprocket, 60A48 x 1 1/4RD, W/Holes	33.	07-3922	8	Nut, Insert, M6 x 1
5.	07-0018	1	Screw, Cap, 3/8-16 x 1	34.	07-4350	2	Shackle, Chain, 3/8 Rnd Pin
6.	07-0045	8	Screw, Cap, 1/2-13 x 1 1/2	35.	08-0029B	2	Flange, Bearing, 2 Hole
7.	07-0117	1	Bolt, Carriage, 1/2 x 2	36.	08-0034	2	Bearing, 7/8Hex, W/Hole
8.	07-0119	4	Bolt, Carriage, 5/8-11 x 1 3/4	37.	08-0067	2	Bearing, 1 1/4, 4 Bolt
9.	07-0156	24	Washer, Flat, 1/2	38.	11-0773	2	Shield, Side, Hood
10.	07-0216	1	Spring, Tension, 1.87 x 10.31	39.	11-1626	1	Bracket, Hood, 11 1/2
11.	07-0217	1	Chain, 1/4, 9 Links	40.	11-3725-48	1	Shaft, Hex, 7/8 x 6 1/2, W/Hole
12.	07-0249	1	Chain, 1/4, 22 Links	42.	11-9220	1	Plate, Retainer, Section, Set
13.	07-1294	5	Nut, Hex, 5/8-11	43.	13-0830	1	Weld, Core, 7 Feet
14.	07-1309	4	Screw, Cap, 1/2-13 x 1 1/4		13-0833	1	Weld, Core, 8 Feet
16.	07-1716	7	Bolt, Carriage, 3/8-16 x 1		01-0529	1	Weld, Core, 9 Feet
17.	07-1717	1	Bolt, Carriage, 3/8-16 x 1 1/4	44.	13-0838	1	Bracket, Hood
18.	07-1718	9	Washer, Lock, Split, 3/8	45.	13-0954-1	1	Weld, Frame, Brush, 7 Feet
19.	07-1762	16	Washer, Lock, Split, 1/2		13-0954-2	1	Weld, Frame, Brush, 8 Feet
20.	07-1764	8	Nut, Hex, 1/2-13		11-9218	1	Weld, Frame, Brush, 9 Feet
21.	07-1783	1	Pin, Spirol, 3/16 x 1 1/2	46.	13-1862	1	Weld, Hood, 180°, 7 Feet
22.	07-1872	5	Washer, Lock, Split, 5/8		13-1867	1	Weld, Hood, 180°, 8 Feet
23.	07-2681	2	Fitting, Zerk, Drive-In, 1/4		13-7317	1	Weld, Hood, 180°, 9 Feet
24.	07-2952	8	Screw, M6 x 1 x 20	47.	13-8256	1	Plate, Chain, Guard, Front
25.	07-3120	4	Washer, Flat, 5/8	48.	13-11412	1	Plate, Chain, Guard, Rear
26.	07-3273	4	Washer, Lock, Split, 5/16	49.	28-1519	1	Safety, Label, Kit
27.	07-3278	4	Nut, Hex, 5/16-18	50.	50-0115	2	Label, Danger, Rotating, Driveline
28.	07-3279	8	Washer, Flat, 3/8	51.	50-0253	1	Label, Logo, Sweepster
29.	07-3438	4	Bolt, Carriage, 5/16-18 x 1				

Brush Head Assembly

Assemblies No. 11-4280 (7 Foot)
11-4193 (8 Foot)
28-0506 (9 Foot)

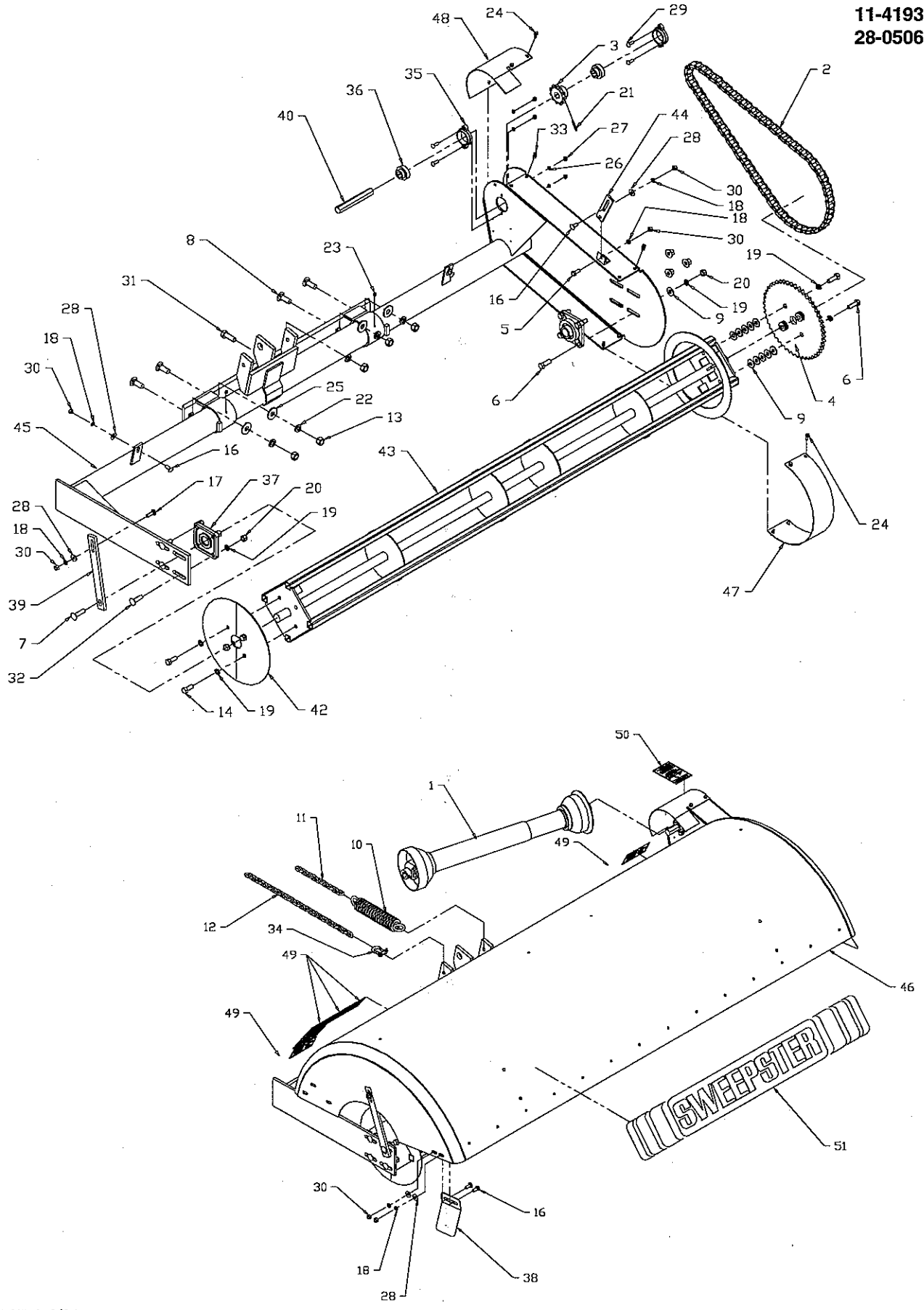

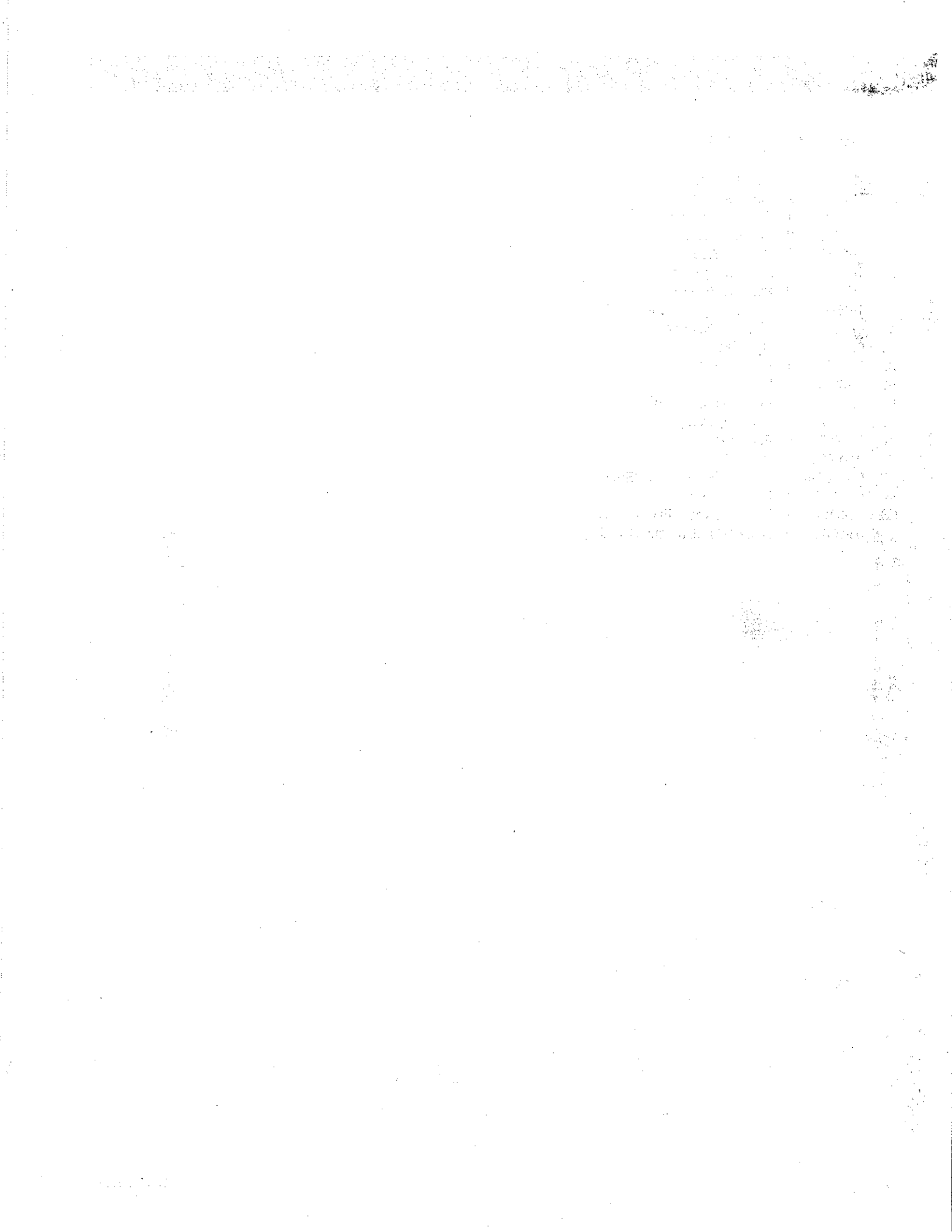

Swing Assembly

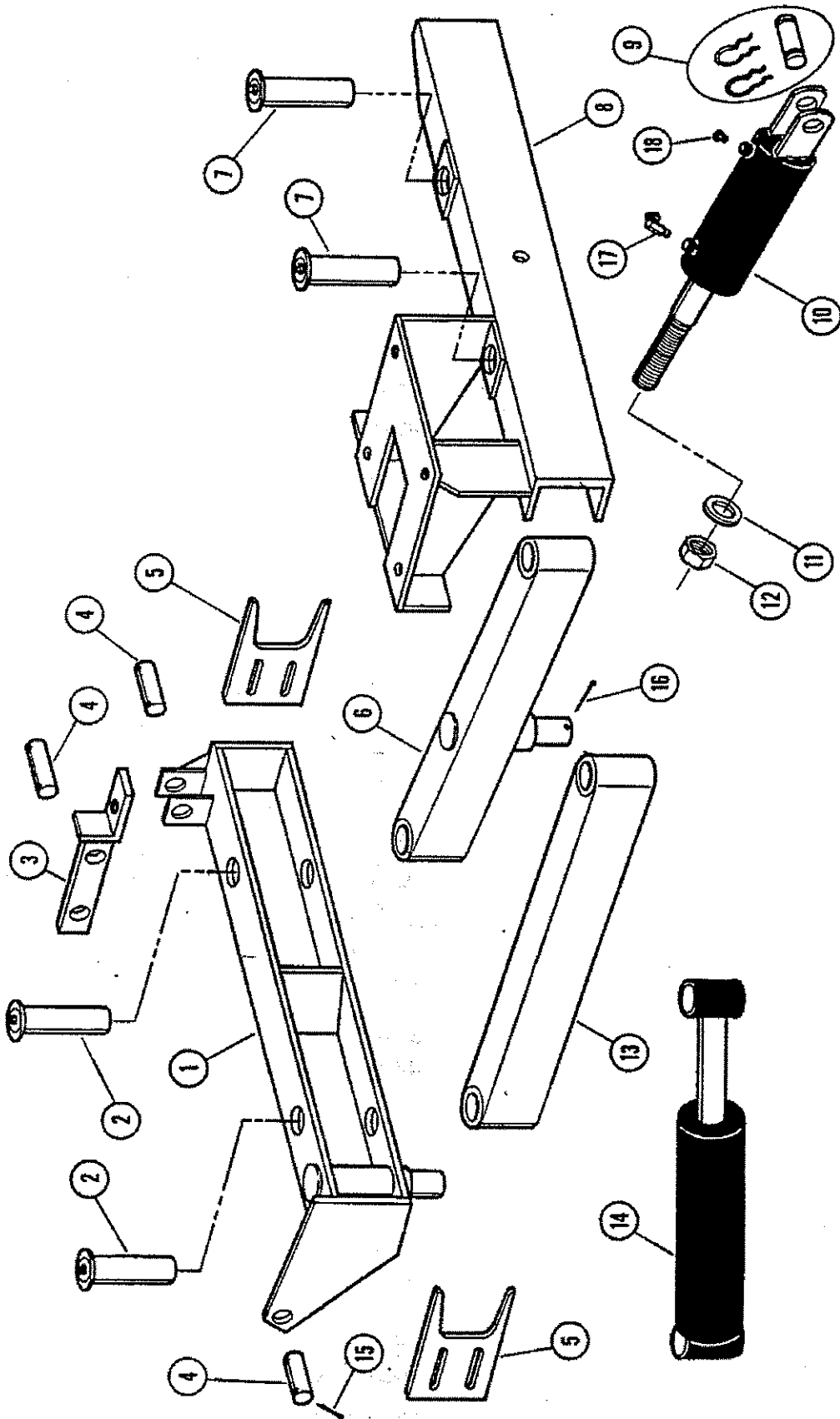

Engine and Drive Components

Ref	Part	Qty	Description
1.	03-0454	1	Fitting, Barb, HP, 90°, 1/4, 1/8MP
2.	03-0815	1	Fitting, STELB, BP, 90°, 1 1/4
3.	03-1173	1	Fitting, Barb, HP, 1/4, 1/4F
4.	07-0156	4	Washer, Flat, 1/2
5.	07-0538	2	Clamp, Screw, MM-4 1/4-5/8
6.	07-1095	2 ft	Hose, Fuel, 1/4
7.	07-1718	8	Washer, Lock, Split, 3/8
8.	07-1730	4	Bolt, Carriage, 3/8-16 x 1 1/2
9.	07-2885	1	Engine, Wisconsin, G, VH4D, Electric Ignition
10.	07-3279	6	Washer, Flat, 3/8
11.	07-3654	8	Nut, Hex, 3/8-16
12.	07-3673	4	Screw, Cap, 1/2-13 x 2 1/2
13.	07-3034	4	Nut, Hex, Lock, 1/2-13
14.	07-4052	4	Screw, Cap, 3/8 x 3/4
17.	11-1520	1	Weld, Mounting, Tank, Gas
18.	11-1523	1	Bracket, Air, Filter
19.	28-0508	1	Assembly, Electric, W/Engine, Wisconsin
20.	50-0213	2	Label, Warning, Rotating Shaft
A.	07-0570	1	Tank, Fuel, 10 Gallon
B.	11-1522	1	Weld, Mounting, Engine

Engine and Drive Components

Assembly No. 11-4195

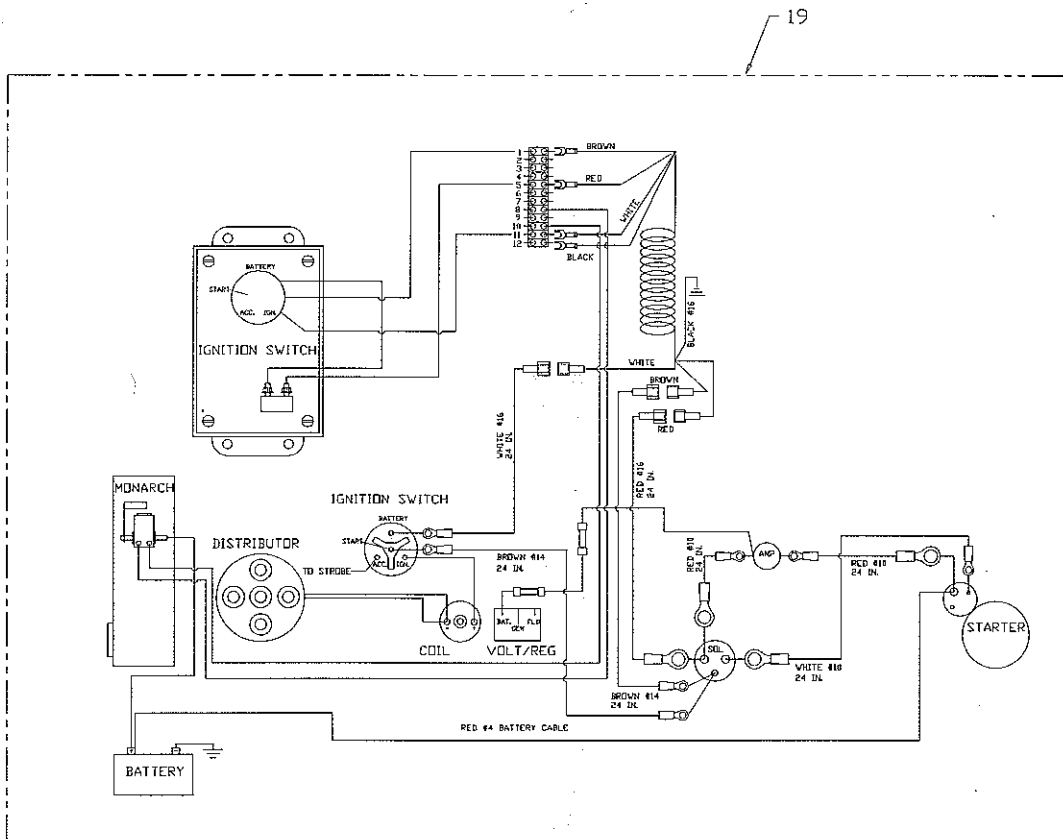
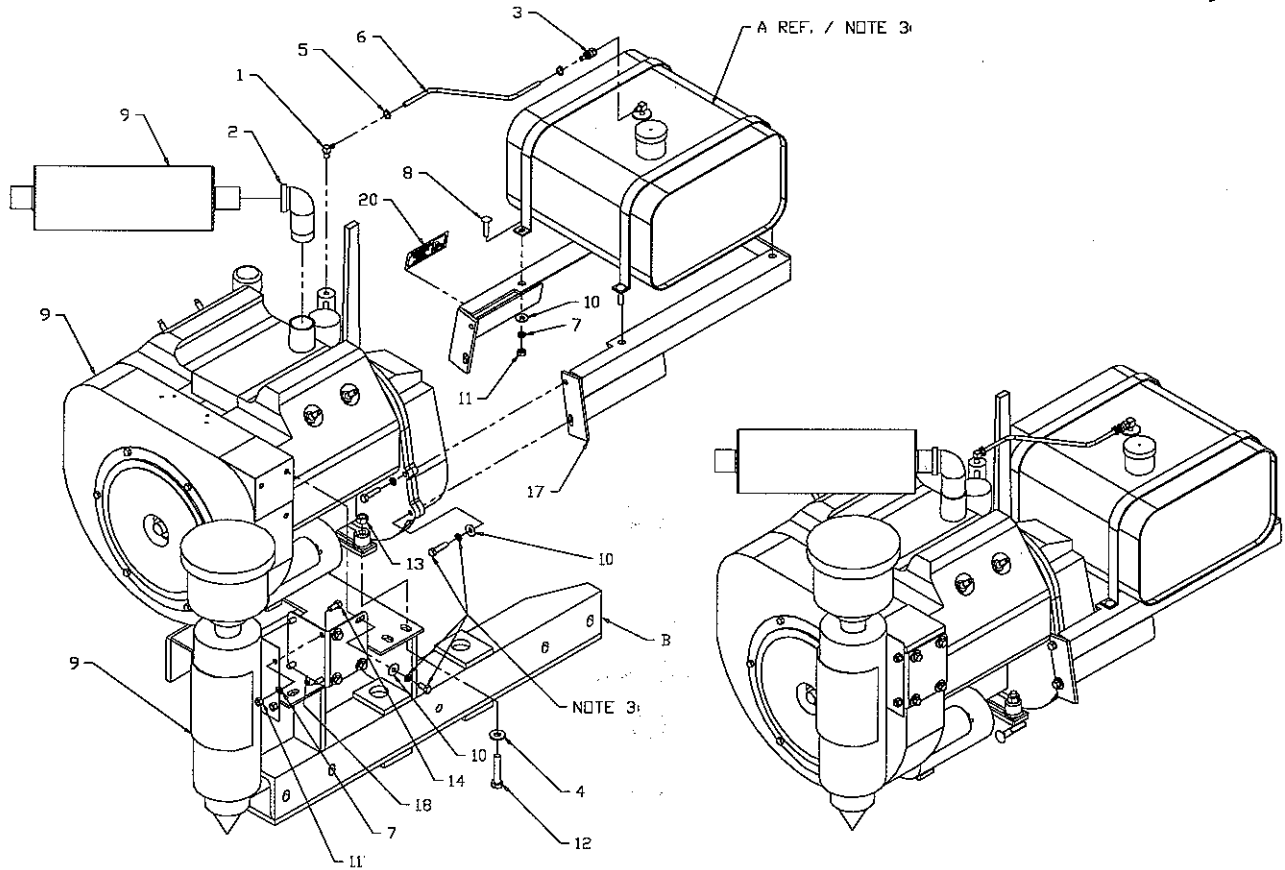

Option – Sprinkler System

Ref	Part	Qty	Description
1.	03-0076	1	Fitting, Nipple, BP, Close, 3/8
2.	03-0152	1	Fitting, Nipple, BP, Close, 1/2
3.	03-0457	1	Fitting, Barb, 3/8, 3/8MP
4.	03-0714	1	Fitting, Barb, HP, 90°, 5/8, 1/2MP
5.	03-0819	1	Fitting, Reducerbushing, BP, 1/2 x 3/8
6.	03-1068-9	1	Fitting, Reducerbushing, HP, 3/4 x 1/2
7.	03-1182-7	1	Fitting, Plug, BP, Square, 1 1/4
8.	03-1226	1	Fitting, Barb, HP, 5/8, 1/2MP
9.	03-1326	1	Pump, Flojet, Water, 2.1 G.P.M., 12Volt
10.	03-1392	1	Valve, Shut-Off, Ball, 1/2
11.	07-0156	4	Washer, Flat, 1/2
12.	07-0367	1	Assembly, Tank, Water, 150 Gal
13.	07-0532	1	Strainer, Hypro, Water
14.	07-0547	2	Clamp, Spring, 7/8 Hose
15.	07-0549	2	Clamp, Spring, 5/8 Hose
16.	07-1762	4	Washer, Lock, Split, 1/2
17.	07-1764	4	Nut, Hex, 1/2-13
18.	07-3637	2	Screw, Cap, 1/4-20 x 1
19.	07-3638	4	Screw, Cap, 1/4-20 x 1 1/4
20.	07-3708	4	Bolt, Carriage, 1/2-13 x 1 1/2
21.	07-4032	6	Washer, Flat, 1/4
22.	07-4033	6	Nut, Hex, Nylock, 1/4-20
23.	07-4037	4	Nut, Hex, Nylock, 1/2-13
24.	09-0028	2 ft	Hose, Heater, 5/8
25.	09-0056	14 ft	Hose, Heater, 3/8
26.	09-0107	1	Strap, Nylon, Tank, 2 x 52
27.	11-7051	4	Weld, Bolt, Tee, Sprinkler
28.	13-1742	1	Weld, Mounting, Tank, Water, 150 Gallon
29.	13-1835	1	Plate, Mounting, ROPS, Strobe
30.	G-Kit66	1	Assembly, Spray Bar (7 Foot)
	G-Kit67	1	Assembly, Spray Bar (8 & 9 Foot)

Option – Sprinkler System

Assembly No. 11-4409(7 Foot)
11-4441 (8 & 9 Foot)

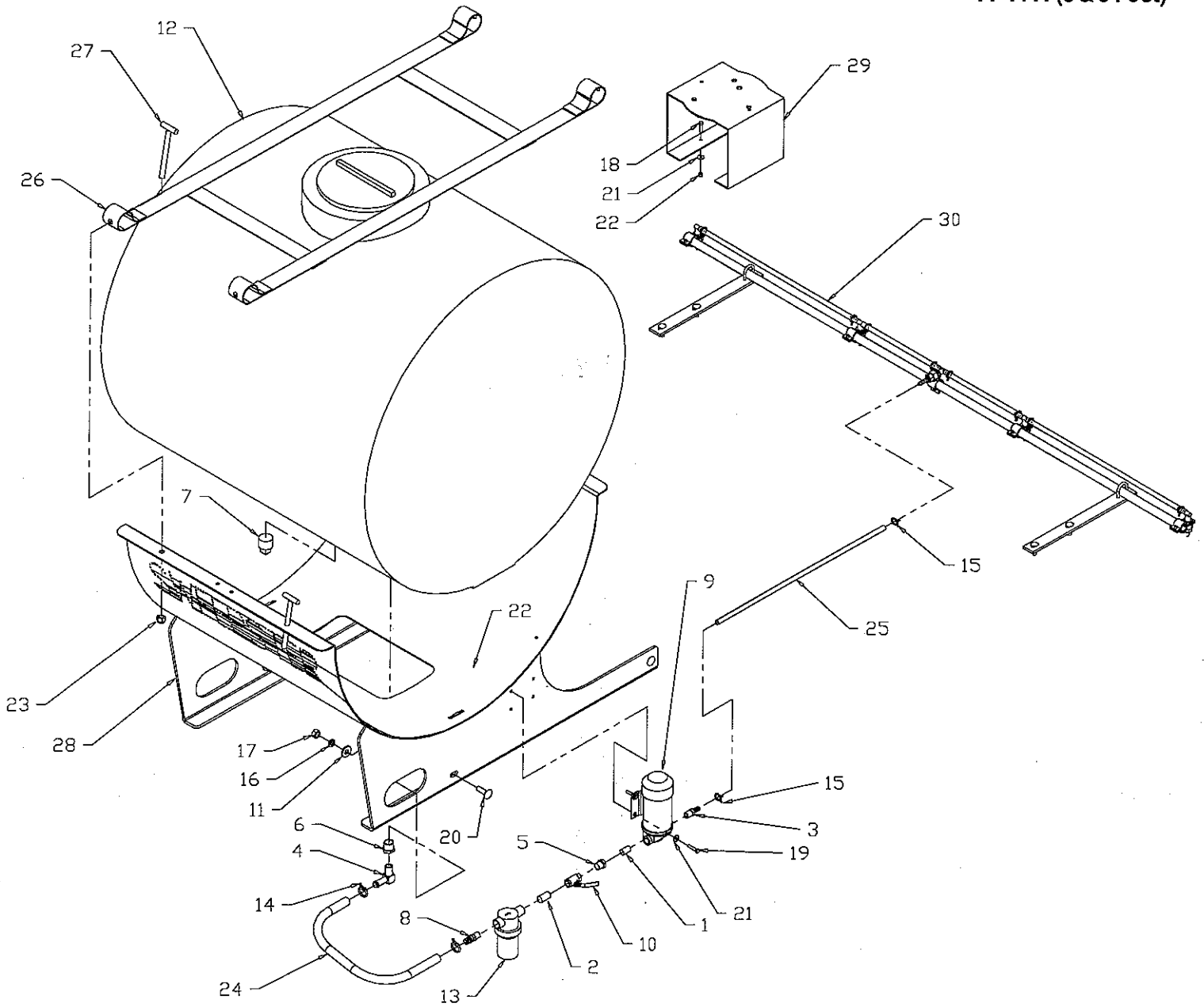

Control Box Assembly

Assembly No. 07-0351-1
Control Box without Cable

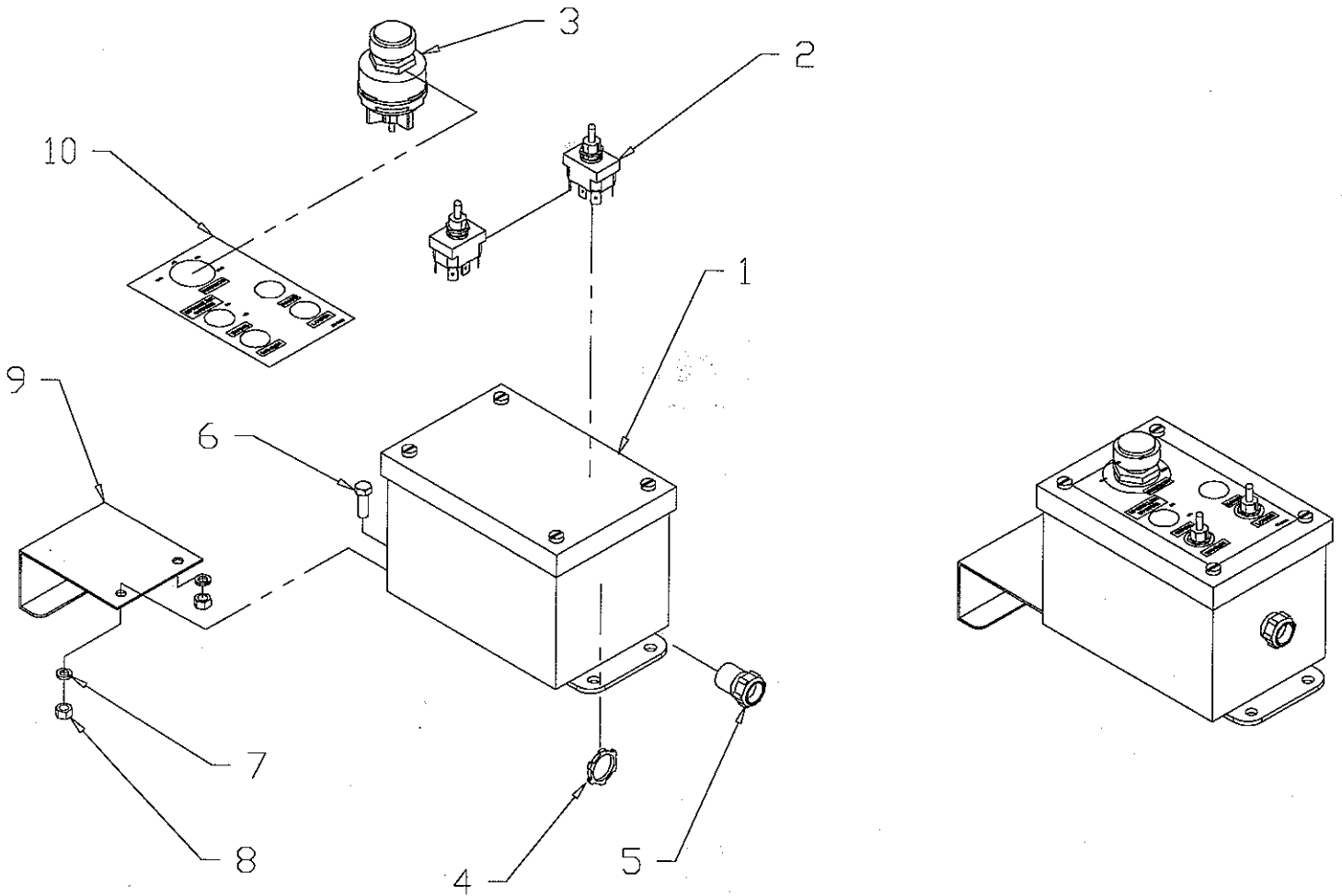

Item Part Qty Description

Item	Part	Qty	Description
1.	07-0351	1	Box, Control, Hoffman
2.	07-0351A	2	Switch, Toggle, 6 Prong
3.	07-0370	1	Switch, Ignition, NG-100
4.	07-0856	1	Nut, Lock, 1/2, F/Strain Relief
5.	07-0857	1	Strain Relief, 1/2 BRN, 16/12
6.	07-3432	2	Screw, Cap, 1/4-20 x 3/4
7.	07-4038	2	Washer, Lock, Split, 1/4
8.	07-4039	2	Nut, Hex, 1/4-20
9.	11-1519	1	Hanger, Control Box
10.	50-0019	1	Label, Control Box

Control Box Assembly

Assembly No. 07-0351-2
Control Box with Cable

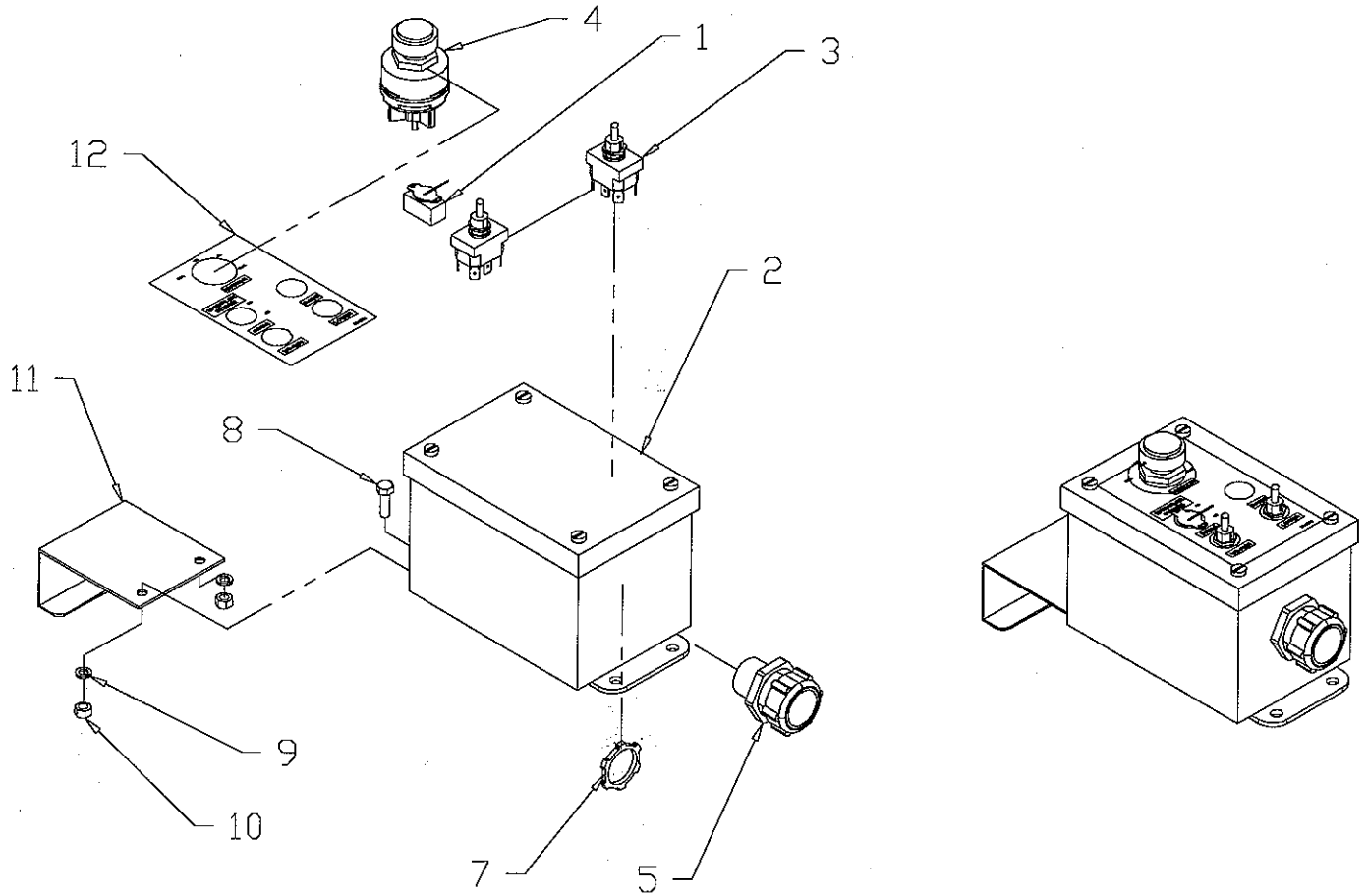

Item Part Qty Description

1.	07-0343	1	Switch, Toggle, 2 Position
2.	07-0351	1	Box, Control, Hoffman
3.	07-0351A	2	Switch, Toggle, 6 Prong
4.	07-0370	1	Switch, Ignition, NG-100
5.	07-1477	1	Strain, Relief, 3/4
7.	07-2245	1	Strain, Relief, Nut, 3/4
8.	07-3432	2	Screw, Cap, 1/4-20 x 3/4
9.	07-4038	2	Washer, Lock, Split, 1/4
10.	07-4039	2	Nut, Hex, 1/4-20
11.	11-1519	1	Hanger, Control Box
12.	50-0019	1	Label, Control Box

Storage

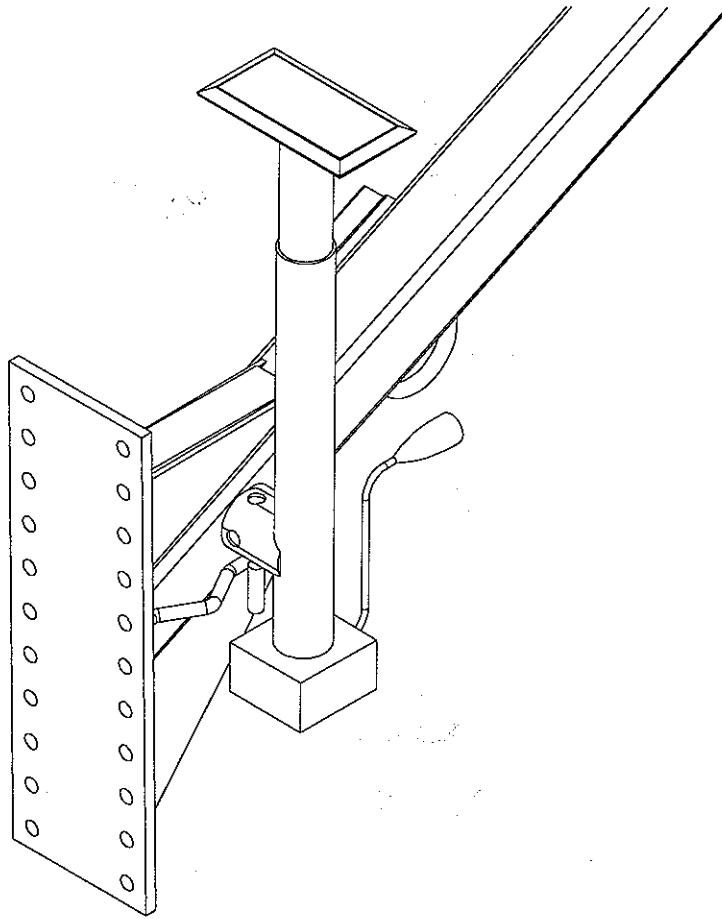

NOTE: RECOMMENDED JACK STAND STORAGE POSITION FOR P&H-

IMPORTANT – To avoid damage to both jack and spraybar, jack should be stored with the sand shoe vertical or forward towards the towering vehicle.

Torque Values

Bolt Torque Specifications

Body Size Grade 5	Ft-lbs		Body Size Class 8.8	Ft-lbs
1/4 - 20	6 ± 1		M6 - 1.0	5 ± 1
- 28	7 ± 1		n/a	-
5/16 - 18	13 ± 3		n/a	-
- 24	14 ± 3		n/a	-
3/8 - 16	23 ± 5		M8 - 1.25	14 ± 3
- 24	26 ± 5		- 1.0	-
7/16 - 14	37 ± 8		M10 - 1.5	29 ± 6
- 20	41 ± 9		- 0.75	-
1/2 - 13	56 ± 11		M12 - 1.75	50 ± 10
- 20	63 ± 12		- 1.0	-
9/16 - 12	82 ± 14		M14 - 2.0	80 ± 14
- 18	91 ± 16		- 1.5	-
5/8 - 11	113 ± 20		M16 - 2.0	125 ± 22
- 18	127 ± 23		- 1.5	-
3/4 - 10	201 ± 26		n/a	-
- 16	223 ± 29		n/a	-
7/8 - 9	321 ± 41		M20 - 2.5	244 ± 31
- 14	355 ± 46		- 1.5	-
1 - 8	483 ± 62		M24 - 3.0	422 ± 54
- 12	528 ± 68		- 2.0	-

Body Size Grade 8	Ft-lbs		Body Size Class 10.9	Ft-lbs
1/4 - 20	9 ± 2		M6 - 1.0	8 ± 1
- 28	10 ± 2		n/a	-
5/16 - 18	18 ± 4		n/a	-
- 24	20 ± 4		n/a	-
3/8 - 16	32 ± 7		M8 - 1.25	20 ± 4
- 24	37 ± 8		- 1.0	-
7/16 - 14	52 ± 11		M10 - 1.5	40 ± 8
- 20	58 ± 12		- 0.75	-
1/2 - 13	80 ± 16		M12 - 1.75	69 ± 14
- 20	90 ± 18		- 1.0	-
9/16 - 12	115 ± 20		M14 - 2.0	110 ± 20
- 18	128 ± 23		- 1.5	-
5/8 - 11	159 ± 28		M16 - 2.0	173 ± 31
- 18	180 ± 32		- 1.5	-
3/4 - 10	282 ± 36		n/a	-
- 16	315 ± 41		n/a	-
7/8 - 9	454 ± 59		M20 - 2.5	337 ± 44
- 14	500 ± 65		- 1.5	-
1 - 8	681 ± 88		M24 - 3.0	583 ± 75
- 12	746 ± 97		- 2.0	-

Foot-pounds may be converted to Newton Meters by multiplying by 1.35582.
 Foot-pounds may be converted to Inch-pounds by dividing by 12.
 If the nut and screw are not the same grade, the lower grade will always be used.

NOTE – Nylock nuts are utilized when greater resistance to vibrating loose is required, and greater operating temperatures are not a factor. In addition, like lock nuts, nylock nuts have a safety feature that if the bolt does vibrate loose, the nut will remain on the screw. Install nylock nuts to the standard torque shown above.

Warranty Information

SWEEPSTER WARRANTY REGISTRATION

Thank you for purchasing a Sweepster product. Warranty protection on this equipment is valid only when completed and signed by customer and dealer and mailed to SWEEPSTER. If you have any questions, please give us a call at 1-800-456-7100 or (734) 996-9116.

PLEASE PRINT - PRESS HARD MULTIPLE COPIES

Purchaser's Name

Address _____ City _____

State _____ Zip _____ Phone _____

Model Number _____ Serial Number _____

Engine Make _____ Engine Model _____

Date Delivered to Dealer _____ Date Delivered to Customer _____

Dealer's Name

Address _____ City _____

State _____ Zip _____ Phone _____

White-Customer Yellow-Dealer Card-Return to Sweepster postage paid

Form: SWR Rev 4/97

1. MATERIAL YOU ARE SWEEPING?

- Snow Dirt General Debris Thatch
 Other _____

2. MAKE AND MODEL NUMBER OF PRIME MOVER.

(For attachment sweepers only.) _____

3. DID YOU OR YOUR CUSTOMER RECEIVE AN OPERATION/PARTS MANUAL? Yes No

4. DID THE UNIT FIT CORRECTLY TO PRIME MOVER?

- Yes No Comments _____

5. WHY DID YOU PURCHASE A SWEEPSTER? (check one)

- Quality Price Reputation Simplicity Prior Use
 Dealer Referral Operation Features Availability
 Other _____

6. PLEASE RATE THE FOLLOWING (check one)

- Appearance: Excellent Good Poor
 Delivery Time: Excellent Good Poor
 Sales Service: Excellent Good Poor
 Performance: Excellent Good Poor
 Technical Support: Excellent Good Poor

7. SUGGESTIONS/COMMENTS?



SWEEPSTER Limited Six Month Warranty

For a period of six (6) months from date of delivery of product to the original user, Sweepster, Inc. of Dexter, Michigan warrants each product to be free from manufacturing defects, subject to the limitations contained in this policy.

This warranty does not apply to defect caused, in whole or in part, by unreasonable use while in the possession of the user, including, but not limited to: failure to properly set up product; failure to provide reasonable and necessary maintenance; normal wear, routine tune ups or adjustments; improper handling or accidents; operation at speed or load conditions contrary to published specifications; improper or insufficient lubrication; improper storage. This warranty is also not a guarantee that the performance of each product will meet the expectations of the purchaser.

Sweepster, Inc. shall not be liable for consequential damages of any kind, including, but not limited to: consequential labor costs or transportation charges in connection with the replacement of repair of defective parts; lost time or expense which may have accrued because of said defects. In no event shall Sweepster, Inc.'s total liability hereunder exceed the product purchase price.

Sweepster, Inc. makes no warranty with respect to trade accessories or any component or accessory of the product which was not manufactured by Sweepster, Inc. including any purchased components of any kind. These are subject to the warranties of their respective manufacturers. The warranty will be considered void if the product or any part of the product is modified or repaired in any way not expressly authorized by Sweepster, Inc., or if closed components are disassembled prior to return. Closed components include, but are not limited to: gearboxes, hydraulic pumps, motors, cylinders, and actuators.

Our obligation under the warranty is expressly limited, at our option, to the replacement or repair at Sweepster, Inc. of Dexter, Michigan, or at a service facility designated by us, or such part or parts as inspection shall disclosed to have been defective. We are not responsible for unauthorized repairs or replacements. Any implied or statutory warranties, including any warranty of merchantability or fitness for a particular purpose, are expressly limited to the duration of this written warranty. We make no other express warranty, nor is anyone authorized to make any in our behalf. This warranty cannot be extended, broadened, or changed except in writing by an authorized officer of Sweepster, Inc.

Glossary – Terms & Abbreviations

BP – black pipe

brush head assembly – assembly that includes the core, hood and brush frame.

brush pattern – area of dirt removed from sweeping surface; with a properly adjusted sweeper, the pattern is the same width for the entire length.

caution – indicates a potentially hazardous situation which, if not avoided, may result in minor or moderate injury.

CV – constant velocity; usually refers to a drive shaft.

core – weldment that holds brush sections.

dirt deflector – kit made of metal and/or rubber parts designed to direct debris away from the operator.

electric lift – means of raising the brush head assembly electrically.

F – female.

FS – face seal.

gpm – gallons per minute.

HP – high pressure.

hood – brush shield.

hydraulic angle kit – means of swinging the brush head assembly hydraulically.

hydraulic lift – means of raising the brush head assembly hydraulically.

important – used for instructions when machine damage may be involved.

in. – inches.

kph – kilometers per hour.

lb – pounds.

left-hand – side that is on the left when facing the normal forward direction of travel of the machine.

lps – liters per second.

M – male.

mm – millimeters.

mph – miles per hour.

manual angle kit – means of swinging the brush head assembly mechanically.

mid pump unit – sweeper in which the pump is mounted on the mid PTO.

mounting assembly – portion of the sweeper that attaches to the prime mover; designed specifically for each prime mover.

NPT – national pipe thread.

note – indicates supplementary information.

OR – O-ring.

psi – pounds per square inch.

PTO – power take off; shaft on the prime mover used to drive attachments.

power pack – auxiliary hydraulic packaged used when prime mover hydraulics do not have enough flow available.

prime mover – refers to the tractor, truck, loader or other vehicle to which a sweeper is attached.

qty – quantity.

rpm – revolutions per minute.

rear pump unit – sweeper in which the pump is mounted on a rear PTO.

retainer – removable plate or set of plates that keeps sections on the core.

right-hand – side that is on the right when facing the normal forward direction of travel of the machine.

Glossary – Terms & Abbreviations

section – single brush wafer.

section set – replacement brush wafers.

spring-chain assembly – assembly that helps keep the sweeper in proper adjustment yet allows it to pivot up and down.

swing assembly – portion of the sweeper that allows the brush head assembly to angle.

stand kit – means of keeping the brush off the ground during storage.

tank assembly – assembly that includes the hydraulic reservoir, filter and fittings; may also incorporate valves.

transport chain – chain that supports the weight of the brush head assembly during transport between work sites and during adjustment of the spring-chain assemblies.

warning – indicates a potentially hazardous situation which, if not avoided, could result in death or serious injury.

windrow – pile of debris.

zerk – grease fitting.