



# OPERATOR'S AND PARTS MANUAL

# FRONT MOUNT SCARIFIER



*The Power of Combined Excellence*

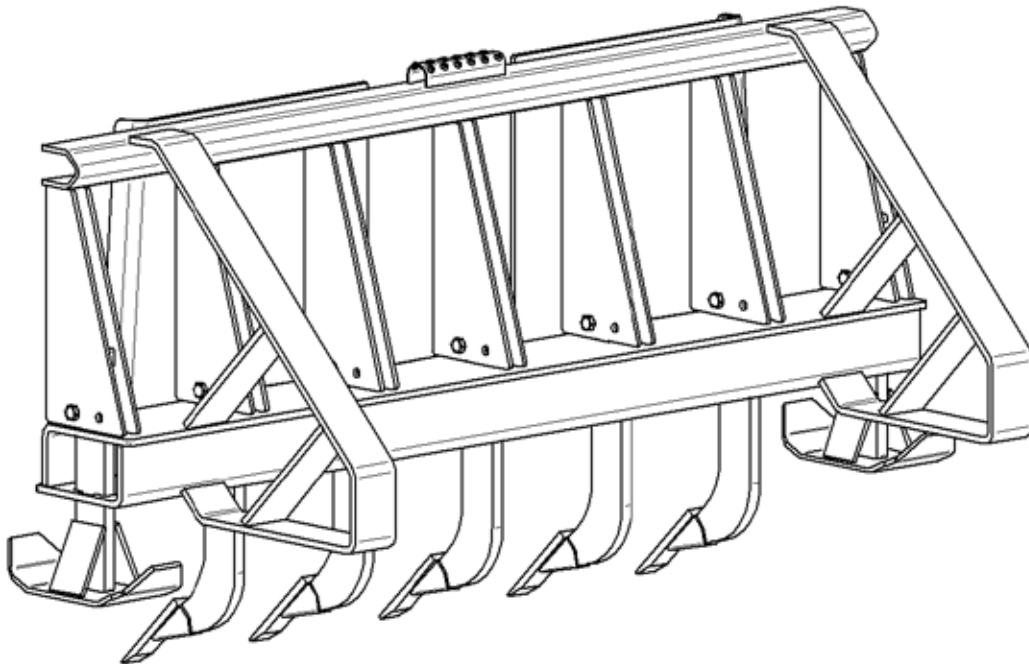

SERIAL NUMBER: \_\_\_\_\_

MODEL NUMBER: \_\_\_\_\_

Manual Number: MR05508

Part Number: LAF2201

Rev. 2



# TABLE OF CONTENTS

INTRODUCTION .....	2
GENERAL INFORMATION .....	2
SERIAL NUMBER .....	2
OWNER AND OPERATOR SAFETY INFORMATION	
SAFETY STATEMENTS .....	3
SAFETY PRECAUTIONS .....	3-5
SAFETY SIGNS .....	6-7
SPECIFICATIONS .....	8-9
ADJUSTMENT & OPERATING PROCEDURE .....	10
PARTS ILLUSTRATION & LIST .....	11
WARRANTY .....	12

# INTRODUCTION

Congratulations on your purchase of a new **FFC Front Mount Scarifier**. This product has been designed and built to efficiently loosen asphalt, hard packed earth and gravel, to allow easy removal with dozer blade or bucket. You or any other person who will be assembling, operating, maintaining, or working with this product are required to read and completely understand the information and instructions contained in this manual. If anyone does not fully understand every part of this manual, please obtain further assistance by contacting the dealer from which this product was purchased or by contacting **FFC** at the telephone number or address listed on the cover of this manual. Keep this manual available for reference whenever this product is being handled or used. Provide this manual to any new owners and/or operators.

This manual covers model: **LAF2201**.

## GENERAL INFORMATION

The purpose of this manual is to assist in assembling, mounting, operating, and maintaining your **Front Mount Scarifier**. Read this manual carefully to obtain valuable information and instructions that will help you achieve years of safe and dependable service.

The illustrations and data used in this manual were current at the time of printing, but due to possible engineering and/or production changes, this product may vary slightly in detail. **FFC** reserves the right to redesign and/or change components as may be necessary without notification to anyone.

Throughout this manual, references may be made to:

Prime Mover	The engine-driven machine to which this product must be attached.
Right, Left, Front, Rear	Directions that are determined in relation to the operator of the equipment when seated in the normal operation position.
<b>IMPORTANT</b>	Precautions that must be followed to prevent substandard performance.

## SERIAL NUMBER LOCATION

Always refer to the model and serial number when ordering parts or requesting information from your dealer. The serial number plate for this product is located on the top left surface of the loader attachment plate of your **Front Mount Scarifier**.

Reference Information	
Model Number	Loader Make
Serial Number	Loader Model
Date Purchased	Loader Serial Number

# SAFETY STATEMENTS



**THIS SYMBOL BY ITSELF OR WITH A WARNING WORD THROUGHOUT THIS MANUAL IS USED TO CALL YOUR ATTENTION TO INSTRUCTIONS INVOLVING YOUR PERSONAL SAFETY OR THE SAFETY OF OTHERS. FAILURE TO FOLLOW THESE INSTRUCTIONS CAN RESULT IN INJURY OR DEATH.**



## **DANGER**

**THIS SIGNAL WORD IS USED WHERE SERIOUS INJURY OR DEATH WILL RESULT IF THE INSTRUCTIONS ARE NOT FOLLOWED PROPERLY.**



## **WARNING**

**THIS SIGNAL WORD IS USED WHERE SERIOUS INJURY OR DEATH COULD RESULT IF THE INSTRUCTIONS ARE NOT FOLLOWED PROPERLY.**



## **CAUTION**

**THIS SIGNAL WORD IS USED WHERE MINOR INJURY COULD RESULT IF THE INSTRUCTIONS ARE NOT FOLLOWED PROPERLY.**

## **NOTICE**

**NOTICE INDICATES A PROPERTY DAMAGE MESSAGE.**

## GENERAL SAFETY PRECAUTIONS

### **WARNING! READ MANUAL PRIOR TO INSTALLATION**



Improper installation, operation, or maintenance of this equipment could result in serious injury or death. Operators and maintenance personnel should read this manual, as well as all manuals related to this equipment and the prime mover thoroughly before beginning installation, operation, or maintenance. **FOLLOW ALL SAFETY INSTRUCTIONS IN THIS MANUAL AND THE PRIME MOVER'S MANUAL(S).**



### **READ AND UNDERSTAND ALL SAFETY STATEMENTS**

Read all safety decals and safety statements in all manuals prior to operating or working on this equipment. Know and obey all OSHA regulations, local laws, and other professional guidelines for your operation. Know and follow good work practices when assembling, maintaining, repairing, mounting, removing, or operating this equipment.



### **KNOW YOUR EQUIPMENT**

Know your equipment's capabilities, dimensions and operations before operating. Visually inspect your equipment before you start, and never operate equipment that is not in proper working order with all safety devices intact. Check all hardware to ensure it is tight. Make certain that all locking pins, latches, and connection devices are properly installed and secured. Remove and replace any damaged, fatigued, or excessively worn parts. Make certain all safety decals are in place and are legible. Keep decals clean, and replace them if they become worn and hard to read.

## GENERAL SAFETY PRECAUTIONS

### WARNING! PROTECT AGAINST FLYING DEBRIS



Always wear proper safety glasses, goggles or a face shield when driving pins in or out, or when any operation causes dust, flying debris, or any other hazardous material.

### WARNING! LOWER OR SUPPORT RAISED EQUIPMENT



Do not work under raised booms without supporting them. Do not use support material made of concrete blocks, logs, buckets, barrels or any other material that could suddenly collapse or shift positions. Make sure support material is solid, not decayed, warped, twisted, or tapered. Lower booms to ground level or onto blocks. Lower booms and attachments to the ground before leaving the cab or operator's station.

### WARNING! USE CARE WITH HYDRAULIC FLUID PRESSURE



Hydraulic fluid under pressure can penetrate the skin and cause serious injury or death. Hydraulic leaks under pressure may not be visible. Before connecting or disconnecting hydraulic hoses, read your prime movers operator's manual for detailed instructions on connecting and disconnecting hydraulic hoses or fittings.

- Keep unprotected body parts, such as face, eyes, and arms as far away as possible from a suspected leak. Flesh injected with hydraulic fluid may develop gangrene or other permanent disabilities.
- If injured by injected fluid, see a doctor at once. If your doctor is not familiar with this type of injury, ask him to research immediately to determine proper treatment.
- Wear safety glasses, protective clothing, and use a sound piece of cardboard or wood when searching for hydraulic leaks. **DO NOT USE YOUR HANDS!** **SEE ILLUSTRATION.**

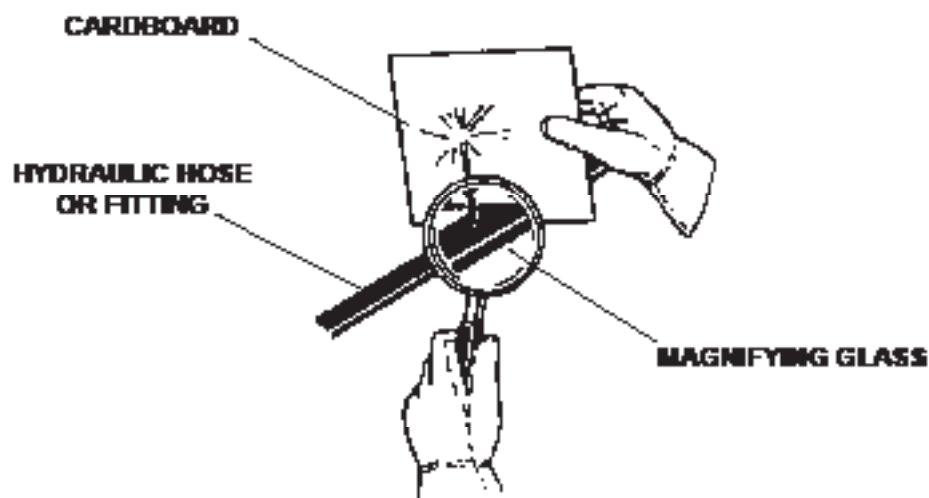

# GENERAL SAFETY PRECAUTIONS

## **WARNING! DO NOT MODIFY MACHINE OR ATTACHMENTS**



Modifications may weaken the integrity of the attachment and may impair the function, safety, life, and performance of the attachment. When making repairs, use only the manufacturer's genuine parts, following authorized instructions. Other parts may be substandard in fit and quality. Never modify any ROPS (Roll Over Protection Structure) or FOPS (Falling Object Protective Structure) equipment or device. Any modifications must be authorized in writing by the manufacturer.

## **WARNING! SAFELY MAINTAIN AND REPAIR EQUIPMENT**



- Do not wear loose clothing, or any accessories that can catch in moving parts. If you have long hair, cover or secure it so that it does not become entangled in the equipment.
- Work on a level surface in a well-lit area.
- Use properly grounded electrical outlets and tools.
- Use the correct tool for the job at hand. Make sure they are in good condition for the task required.
- Wear the protective equipment specified by the tool manufacturer.

## **WARNING! SAFELY OPERATE EQUIPMENT**



Do not operate equipment until you are completely trained by a qualified operator in how to use the controls, know its capabilities, dimensions, and all safety requirements. See your machine's manual for these instructions.

- Keep all step plates, grab bars, pedals, and controls free of dirt, grease, debris, and oil.
- Never allow anyone to be around the equipment when it is operating.
- Do not allow riders on the attachment or the prime mover.
- Do not operate the equipment from anywhere other than the correct operators position.
- Never leave equipment unattended with the engine running or with this attachment in a raised position.
- Do not alter or remove any safety feature from the prime mover or this attachment.
- Know your work site safety rules as well as traffic rules and flow. When in doubt on any safety issue, contact your supervisor or safety coordinator for an explanation.

## **WARNING! KNOW WHERE UTILITIES ARE**



Observe overhead electrical and other utility lines. Be sure equipment will clear them. When digging, call your local utilities for location of buried utility lines, gas, water, and sewer, as well as any other hazard you may encounter.

# SAFETY SIGN LOCATIONS

The diagram on this page shows the location of the decals used on the FFC Front Mount Scarifier. The decals are identified by their part numbers, with reductions of the actual decals located on the following page. Use this information to order replacements for lost or damaged decals. Be sure to read all decals before operating the attachment. They contain information you need to know for both safety and product longevity.

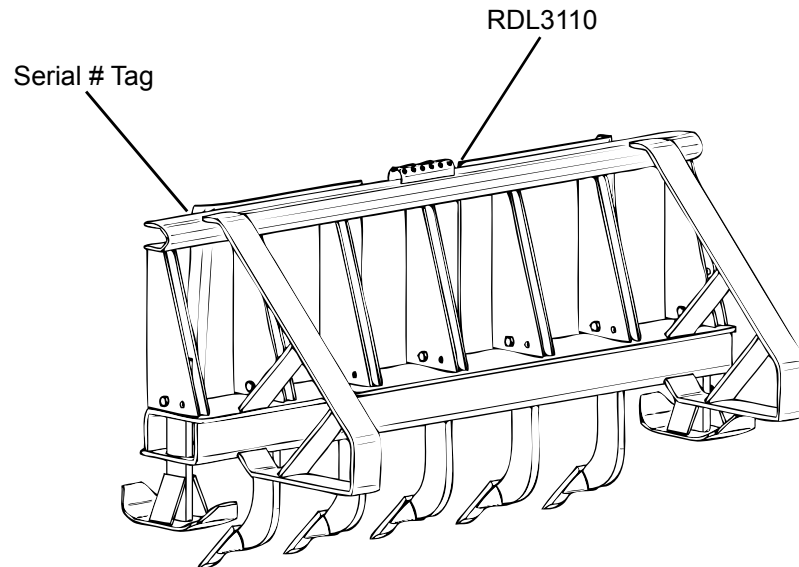

## INSTRUCTIONS

- Keep all safety signs clean and legible.
- Replace all missing, illegible, or damaged safety signs.
- Replacement parts for parts with safety signs attached must also have safety signs attached.
- Safety signs are available, free of charge, from your dealer or from FFC.

## PLACEMENT OR REPLACEMENT OF SAFETY SIGNS

1. Clean the area of application with non-flammable solvent, and then wash the same area with soap and water.
2. Allow the surface to fully dry.
3. Remove the backing from the safety sign, exposing the adhesive surface.
4. Apply the safety sign to the position shown in the diagram above and smooth out any bubbles.



## SAFETY SIGNS

**ATTENTION:**  
**ROLLING DUMP CYLINDERS TOO FAR FORWARD  
WILL CAUSE SEVERE TIRE DAMAGE.**

PART # RDL3110

ATTENTION: SEVERE TIRE DAMAGE

## PRIME MOVER SPECIFICATIONS

**IMPORTANT** Exceeding any of the maximum recommended prime mover specifications **CAN** result in damage to this product and **WILL** void all FFC warranties.

DESCRIPTION	SPECIFICATIONS
Weight of Prime Mover without Front Mount Scarifier	11,000 lbs. maximum
Rear Ballast	As required to maintain full prime mover stability. (Note the Shipping Weight on the specifications page, then see the operator's manual(s) for your prime mover, loader, and quick-attach for ballasting needs.)

**NOTICE** Make sure your prime mover is producing the manufacturer's specified hydraulic flow (gpm) and pressure (psi), especially for operation at high altitudes. Using prime movers with less than specified flow or pressure will cause your Front Mount Scarifier to perform in a substandard manner.

## FRONT MOUNT SCARIFIER SPECIFICATIONS

Model Number	Overall Width	Overall Height	Overall Depth	Ripping Depth*	Shipping Weight**
LAF2201	60"	29"	25"	1/2" to 6"	352 lbs.

\*Up to 7-1/2" maximum depth with skid shoes off (depths may vary on different prime mover models).

\*\*Shipping weights vary depending on loader mounting.

# BOLT TORQUE







## BOLT TORQUE SPECIFICATIONS

### GENERAL TORQUE SPECIFICATION TABLES

Use the following charts when determining bolt torque specifications when special torques are not given. Always use grade 5 or better when replacing bolts.

### SAE BOLT TORQUE SPECIFICATIONS

**NOTE:** The following torque values are for use with extreme pressure lubricants, plating or hard washer applications increase torque 15% when using hardware that is unplated and either dry or lubricated with engine oil.

Bolt Size		SAE GRADE 2 TORQUE				SAE GRADE 5 TORQUE				Bolt head identification marks as per grade. NOTE: Identification Marks Vary
		Pounds-Foot		Newton-Meters		Pounds-Foot		Newton-Meters		
Inches	Millimeters	UNC	UNF	UNC	UNF	UNC	UNF	UNC	UNF	
1/8	6.35	8	8	11	12	18	19	18	20	<p style="text-align: center;">GRADE 2</p>  <p style="text-align: center;">GRADE 5</p>    <p style="text-align: center;">GRADE 8</p>   
9/16	7.31	14	15	19	20	28	29	27	30	
3/8	9.53	20	20	26	28	38	40	32	35	
7/16	11.21	26	26	32	33	45	47	41	45	
1/2	12.70	35	35	42	44	58	61	52	56	
9/16	14.29	44	44	54	56	75	78	66	71	
5/8	15.88	55	55	67	70	92	96	81	87	
3/4	19.05	70	70	85	88	115	120	100	107	
7/8	22.23	88	88	106	110	145	151	125	133	
1	25.40	108	108	130	135	175	182	150	159	
1-1/8	29.17	135	135	162	168	220	228	187	198	
1-1/4	31.75	162	162	195	201	265	274	225	237	
1-3/8	34.93	195	195	235	242	320	330	268	281	
1-1/2	38.10	235	235	285	293	390	400	322	336	

### METRIC BOLT TORQUE SPECIFICATIONS

**NOTE:** The following torque values are for use with metric hardware that is unplated and either dry or lubricated with engine oil. Reduce torque 15% when using hardware that has extreme pressure lubricants, plating or hard washer applications.

Bolt head identification on marks as per grade.



Size of Bolt	Grade No.	Pitch (mm)	Pounds-Foot	Newton-Meters	Pitch (mm)	Pounds-Foot	Newton-Meters
M6	5.6	1.0	3.0-5.0	4.0-7.0	-	-	-
	8.8		5.0-6	7.0-12.7		-	-
	10.9		7.0-10	9.0-13.0		-	-
M8	5.6	1.25	7.0-10	9.0-10	1.0	12-17	16.3-20
	8.8		17-22	20-29.0		19-27	26.7-36.0
	10.9		20-26	27.1-40.2		22-31	29.8-42
M10	5.6	1.0	20-26	27.1-43.0	1.25	29-39	27.1-36.3
	8.8		34-40	46.1-64.2		36-47	47.4-62.7
	10.9		39-46	61.8-82.3		49-62	64.2-78.8
M12	5.6	1.75	29-34	37.8-46.1	1.25	31-41	42-50.3
	8.8		51-60	69.1-76.0		50-60	70.9-82.1
	10.9		57-66	77.2-88.4		62-70	84.1-94.9
M14	5.6	2.0	40-50	56.4-70.0	1.0	52-64	70.9-85.7
	8.8		61-80	100.0-120		80-100	123-143.0
	10.9		80-100	130.1-147.7		107-124	146-160
M16	5.6	2.0	57-77	80.3-104.3	1.0	89-93	103.0-112.0
	8.8		100-130	137.2-179.2		120-130	163.0-197
	10.9		120-140	174.0-199.0		140-160	190.7-214.1
M18	5.6	2.0	80-100	110.2-130	1.0	100-117	130-160.0
	8.8		100-160	203.0-227.0		177-190	230.0-260.0
	10.9		170-190	237.1-262.0		202-231	273.7-313
M20	5.6	2.0	100-130	140.3-170.2	1.0	132-160	170.0-200.0
	8.8		160-200	202-277.0		200-242	270.1-327.0
	10.9		210-240	290.0-327.4		240-290	330.0-391.0

## FRONT MOUNT SCARIFIER SKIDSHOE ADJUSTMENT

1. Skidshoes may be raised or lowered in 1/2" increments to rip from 1/2" depth to 6" depth. They may also be removed to attain 7-1/2" depth. (Depths may vary on different models of prime movers.
2. To adjust:
  - Lower Scarifier close to ground, set parking brake, stop engine and wait for all moving parts to stop before dismounting.
  - Loosen the 1/2" locknut and remove the 1/2" bolt that holds the skidshoe in place.
  - Raise or lower the skidshoe to the desired position. (Note: Both edges of the skidshoe are notched for the bolt to pass through. If you use the other bolt hole, different adjustment heights will be available.)
  - Replace the 1/2" bolt and lock nut.
  - Tighten the lock nut securely.

## FRONT MOUNT SCARIFIER SHANK ADJUSTMENT

1. The Scarifier shanks can be adjusted to a high or a low position.
2. To adjust:
  - Lower Scarifier close to ground, set parking brake, stop engine and wait for all moving parts to stop before dismounting.
  - Loosen the 1/2" locknut and remove the 1/2" bolt that holds the shank in place.
  - Raise or lower the shank to the desired position.
  - Replace the 1/2" bolt and lock nut.
  - Tighten the lock nut securely.

NOTE: Make certain that the shanks are installed with the points pointing toward the machine.

## FRONT MOUNT SCARIFIER OPERATION

- Read and completely understand this manual before operating.
- NOTE: This attachment is designed to be used while driving the machine in reverse.
- Lower the attachment to the desired depth while slowly backing up.
- Continue in reverse until row is completed.
- Raise the attachment and maneuver the prime mover to begin the next row and repeat procedure until done.

# FRONT MOUNT SCARIFIER PARTS ILLUSTRATION & LIST

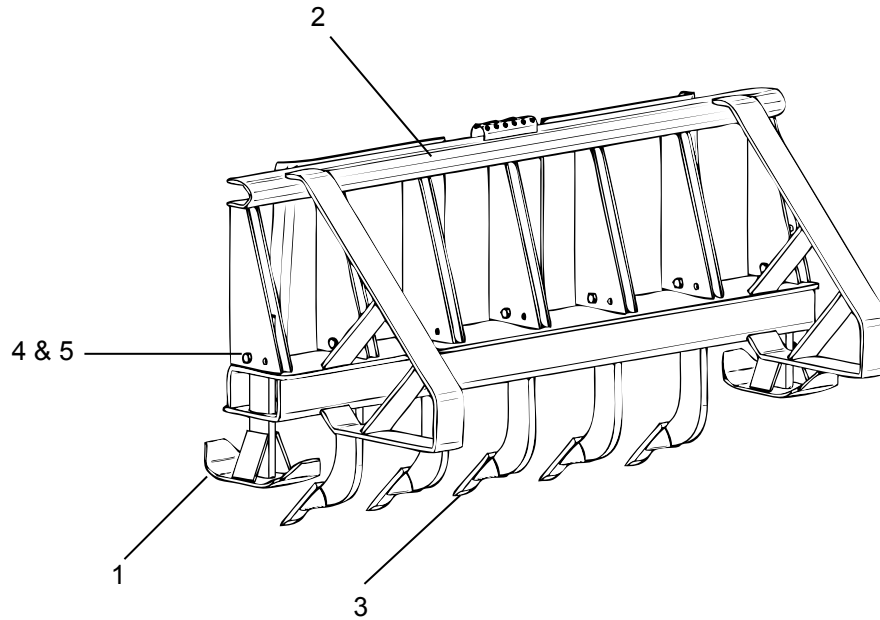

ITEM	QTY.	LAF2201	DESCRIPTION
1	2	LAF2202	Skid Shoe Weldment
2	1	LAF2204	Main-Frame Weldment
3	5	LAF3896	Ripper Shank / Tooth Assembly
4	7	RHW1407	Screw Hex Cap .50-13 x 2.00 Gr5
5	7	RHW7403	Center Dent Lock Nut .50 Gr5

## Limited Warranty

Except for the Excluded Products as described below, all new products are warranted to be free from defects in material and/or workmanship during the Warranty Period, in accordance with and subject to the terms and conditions of this Limited Warranty.

1. Excluded Products. The following products are excluded from this Limited Warranty:

(a) Any cable, part that engages with the ground (i.e. sprockets), digging chain, bearing, teeth, tamping and/or demolition head, blade cutting edge, pilot bit, auger teeth and broom brush that either constitutes or is part of a product.

(b) Any product, merchandise or component that, in the opinion of Paladin Light Construction<sup>1</sup>, has been (i) misused; (ii) modified in any unauthorized manner; (iii) altered; (iv) damaged; (v) involved in an accident; or (vi) repaired using parts not obtained through Paladin Light Construction.

2. Warranty Period. The Limited Warranty is provided only to those defects that occur during the Warranty Period, which is the period that begins on the first to occur of: (i) the date of initial purchase by an end-user, (ii) the date the product is first leased or rented, or (iii) the date that is six (6) months after the date of shipment by Paladin Light Construction as evidenced by the invoiced shipment date (the "Commencement Date") and ends on the date that is twelve (12) months after the Commencement Date.

3. Terms and Conditions of Limited Warranty. The following terms and conditions apply to the Limited Warranty hereby provided:

(a) Option to Repair or Replace. Paladin Light Construction shall have the option to repair or replace the product.

(b) Timely Repair and Notice. In order to obtain the Limited Warranty, (i) the product must be repaired within thirty (30) days from the date of failure, and (ii) a claim under the warranty must be submitted to Paladin Light Construction in writing within thirty (30) days from the date of repair.

(c) Return of Defective Part or Product. If requested by Paladin Light Construction, the alleged defective part or product shall be shipped to Paladin Light Construction at its manufacturing facility or other location specified by Paladin Light Construction, with freight PRE-PAID by the claimant, to allow Paladin Light Construction to inspect the part or product.

Claims that fail to comply with any of the above terms and conditions shall be denied.

### **LIMITATIONS AND EXCLUSIONS.**

**THIS LIMITED WARRANTY IS IN LIEU OF ALL OTHER WARRANTIES, EXPRESS OR IMPLIED, INCLUDING WITHOUT LIMITATION THE WARRANTIES OF MERCHANTABILITY, FITNESS FOR A PARTICULAR PURPOSE AND ANY WARRANTY BASED ON A COURSE OF DEALING OR USAGE OF TRADE.**

**IN NO EVENT SHALL PALADIN LIGHT CONSTRUCTION BE LIABLE FOR CONSEQUENTIAL OR SPECIAL DAMAGES.**

**IN NO EVENT SHALL PALADIN LIGHT CONSTRUCTION BE LIABLE FOR ANY LOSS OR CLAIM IN AN AMOUNT IN EXCESS OF THE PURCHASE PRICE, OR, AT THE OPTION OF PALADIN LIGHT CONSTRUCTION, THE REPAIR OR REPLACEMENT, OF THE PARTICULAR PRODUCT ON WHICH ANY CLAIM OF LOSS OR DAMAGE IS BASED. THIS LIMITATION OF LIABILITY APPLIES IRRESPECTIVE OF WHETHER THE CLAIM IS BASED ON BREACH OF CONTRACT, BREACH OF WARRANTY, NEGLIGENCE OR OTHER CAUSE AND WHETHER THE ALLEGED DEFECT IS DISCOVERABLE OR LATENT.**

<sup>1</sup>Attachment Technologies Inc., a subsidiary of Paladin Brands Holding, Inc. (PBHI) is referred to herein as Paladin Light Construction.

February 10, 2010

