



Scrap Grapple Buckets

For skid-steer loaders, utility loaders, wheel loaders, & backhoe loaders

FEATURES

- Patented design withstands the demands of work in scrap handling, recycling, and other tough applications
- Full feature includes hardened pins, cushioned cylinder kit, & cylinder/hose guard for model 120 & Forked Scrap Grapple
- Model 120 full featured shown below



PALADIN LIGHT CONSTRUCTION



Forked Scrap Grapple

FORKED SCRAP GRAPPLE (FOR SSL, COMPACT UTILITY LOADERS, SMALL WHEEL LOADERS AND BACKHOE LOADERS)

FEATURES:

- Ideal for brush and refuse removal; load loose material leaving dirt behind
- Grapples work independently to handle uneven loads
- 3/8" thick end plates
- 2.25" x 38.75" round tines
- Hardened sleeves at pivot points
- 29" useable tine
- Patented cushioned and sleeved cylinders are 2" x 8" x 1¼" on full feature

IMPORTANT: All replacement hydraulic hoses and fittings must have a minimum rated working pressure of 4000 psi. Hoses and hydraulic couplers from the attachment to the loader are included for skid-steer only.

LAF #	Weight (approx.)	Width ID	Height Open	Height Closed	Depth	Tine Length	Tines
Full Featured*			A	B	C	D	
10167*	1,303 lbs	66"	42.5"	17.3"	40.5"	29"	10
10173*	1,514 lbs	72"	42.5"	17.3"	40.5"	29"	11
10179*	1,542 lbs	78"	42.5"	17.3"	40.5"	29"	12
10185*	1,577 lbs	84"	42.5"	17.3"	40.5"	29"	13
Standard Featured							
10067	1,266 lbs	66"	42.5"	17.3"	40.5"	29"	10
10073	1,301 lbs	72"	42.5"	17.3"	40.5"	29"	11
10079	1,329 lbs	78"	42.5"	17.3"	40.5"	29"	12
10085	1,364 lbs	84"	42.5"	17.3"	40.5"	29"	13

Carrier Specifications:
lift capacities <10,000 lbs
operating weight <20,000 lbs

***NOTE:** Full Featured includes hardened pin, cushioned cylinder kit & cylinder/hose guard.

Specifications and design are subject to change without notice and without liability, therefore, whenever applicable specifications are in accordance with SAE standards.

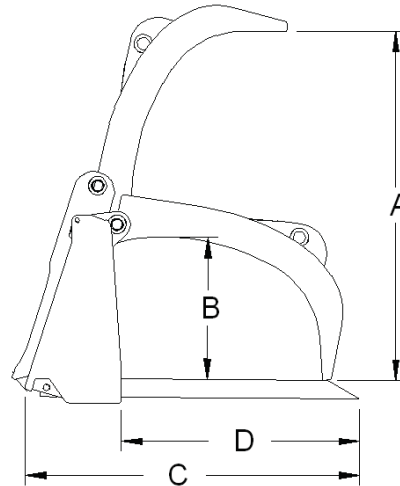

PH: (800) 747-2132
FX: (815) 824-2620

100 East Lee Road
Lee, IL 60530
United States of America

www.paladinbrands.com

F-Scrap Grapple 0702-1



PALADIN LIGHT CONSTRUCTION