



GRADER RAKE

For Skid Steer Loaders



FFC Grader Rakes, by Paladin, have a forward facing design with a full floating hitch that allows the rake to move with the terrain. Efficiently removes debris and levels ground.



- Tines increase digging action for grading and separates debris for site clean-up
- Scarifies and levels hard-packed soil when grading
- Increases productivity over conventional rakes by operating in a forward direction
- Features a full-floating design to follow compound grades; oscillates from side to side for crowning roads

GRADER RAKES

- Heavy duty, adjustable, front mounted castors keep the attachment working the ground and leveling it quickly
- Available in four sizes: 82", 92", 97" & 102"

Specifications	LAF6682	LAF6692	LAF6697	LAF6602
Weight (app.) lbs.	715	750	775	790
Max. Angle	28.5°	28.5°	28.5°	28.5°
A. Width (OD)	82.5"	92.8"	97.9"	103.1"
Cutting Width				
Straight	81.5"	91.75"	97"	102"
B. Max. Angle	71.625"	80.625"	85.25"	89.75"
C. Height	33"	33"	33"	33"
D. Depth	72"	72"	72"	72"

Carrier Specifications:

lift capacities < 9,000 lbs.
operating weight < 11,000 lbs.

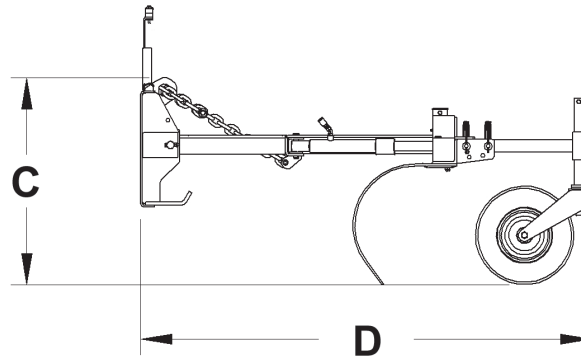
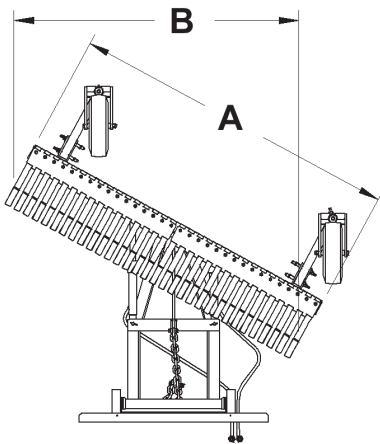

When work needs to get done you need to be able to depend on your equipment. Our Grader Rakes are designed for maximum reliability, durability, and productivity.