



BRADCO

BY PALADIN

OPERATOR'S MANUAL

GROUND SHARK STANDARD DUTY BRUSH CUTTER



SERIAL NUMBER: _____

MODEL NUMBER: _____

Manual Number: OM834
Part Number: 75734
Rev. 4

READ ENTIRE OPERATOR'S & PARTS MANUAL BEFORE OPERATING!

DANGER!



ROTATING BLADE HAZARD! STAY BACK!

OBJECTS CAN BE THROWN!

DO NOT operate near bystanders.

DO NOT place hands or feet under deck while in operation or with engine running.

DO NOT operate without a shatterproof door (or front shield) installed on loader.

WARNING!



Before leaving the operator's seat: Lower the lift arms against frame and place unit on the ground. Disengage auxiliary hydraulics. Stop Engine. Engage parking brake. Remove key.

WARNING!



Operating the standard flow brush cutter on a high flow hydraulic system may cause severe injury or death to the operator or bystanders due to the increased RPM. Do NOT operate the standard flow brush cutters on high flow hydraulic systems.

DANGER!



FLYING DEBRIS HAZARD. CLEAR AREA OF BYSTANDERS AND LIVESTOCK BEFORE OPERATING. THE BRUSH CUTTER IS CAPABLE OF PRODUCING LARGE AMOUNTS OF FLYING DEBRIS IN ALL DIRECTIONS.

WARNING!



Lift Limiting chains must be properly installed before operation.

WARNING!



These BRADCO Brush Cutters should never be operated with the back of the unit more than 12" (305 mm) above the ground.

If there is any portion of this manual or function you do not understand, contact your local authorized dealer or the manufacturer.

TABLE OF CONTENTS

PREFACE	3
SAFETY PRECAUTIONS	
Safety Statements	5
General Safety Precautions.....	5-7
Equipment Safety Precautions	8-9
DECALS	10-12
PREOPERATION	13
INSTALLATION INSTRUCTIONS	14
OPERATING INSTRUCTIONS	
Intended Use	15
General Information.....	15
Operating Tips	15
Cutting Operation	16-17
Troubleshooting Operating Conditions	17
Storage	18
Lift Points.....	18-19
Tie Down Points.....	19
Transporting.....	19
LUBRICATION	20
MAINTENANCE AND SERVICE	
Maintenance Schedule	21
Replacing Blades.....	22-23
Replacing Hydraulic Motor	23-24
Replacing Drive Bearing Housing.....	24-25
Changing Oil.....	26
TROUBLESHOOTING	27
SPECIFICATIONS	
Brush Cutter Specifications	28
Bolt Torque Specifications	29
LIMITED WARRANTY	31

**THIS PAGE
IS INTENTIONALLY
BLANK**

PREFACE

GENERAL COMMENTS

Congratulations on the purchase of your new BRADCO product! This product was carefully designed and manufactured to give you many years of dependable service. Only minor maintenance (such as cleaning and lubricating) is required to keep it in top working condition. Be sure to observe all maintenance procedures and safety precautions in this manual and on any safety decals located on the product and on any equipment on which the attachment is mounted.

This manual has been designed to help you do a better, safer job. Read this manual carefully and become familiar with its contents.

WARNING! Never let anyone operate this unit without reading the "Safety Precautions" and "Operating Instructions" sections of this manual.



Always choose hard, level ground to park the vehicle on and set the brake so the unit cannot roll.

Unless noted otherwise, right and left sides are determined from the operator's control position when facing the attachment.

NOTE: The illustrations and data used in this manual were current (according to the information available to us) at the time of printing, however, we reserve the right to redesign and change the attachment as may be necessary without notification.

BEFORE OPERATION

The primary responsibility for safety with this equipment falls to the operator. Make sure the equipment is operated only by trained individuals that have read and understand this manual. If there is any portion of this manual or function you do not understand, contact your local authorized dealer or the manufacturer to obtain further assistance. Keep this manual available for reference. Provide the manual to any new owners and/or operators.

SAFETY ALERT SYMBOL



This is the "Safety Alert Symbol" used by this industry. This symbol is used to warn of possible injury. Be sure to read all warnings carefully. They are included for your safety and for the safety of others working with you.

SERVICE

Use only manufacturer replacement parts. Substitute parts may not meet the required standards.

Record the model and serial number of your unit on the cover of this manual. The parts department needs this information to insure that you receive the correct parts.

SOUND AND VIBRATION

Sound pressure levels and vibration data for this attachment are influenced by many different parameters: some items are listed below (not inclusive):

- prime mover type, age, condition, with or without cab enclosure and configuration
- operator training, behavior, stress level
- job site organization, working material condition, environment

Based on the uncertainty of the prime mover, operator, and job site, it is not possible to get precise machine and operator sound pressure levels or vibration levels for this attachment.

NOTE: A list of all Paladin Patents can be found at <http://www.paladinbrands.com/patents.asp>.

**THIS PAGE
IS INTENTIONALLY
BLANK**

SAFETY STATEMENTS



THIS SYMBOL BY ITSELF OR WITH A WARNING WORD THROUGHOUT THIS MANUAL IS USED TO CALL YOUR ATTENTION TO INSTRUCTIONS INVOLVING YOUR PERSONAL SAFETY OR THE SAFETY OF OTHERS. FAILURE TO FOLLOW THESE INSTRUCTIONS CAN RESULT IN INJURY OR DEATH.



DANGER

THIS SIGNAL WORD IS USED WHERE SERIOUS INJURY OR DEATH WILL RESULT IF THE INSTRUCTIONS ARE NOT FOLLOWED PROPERLY.



WARNING

THIS SIGNAL WORD IS USED WHERE SERIOUS INJURY OR DEATH COULD RESULT IF THE INSTRUCTIONS ARE NOT FOLLOWED PROPERLY.



CAUTION

THIS SIGNAL WORD IS USED WHERE MINOR INJURY COULD RESULT IF THE INSTRUCTIONS ARE NOT FOLLOWED PROPERLY.

NOTICE

NOTICE INDICATES A PROPERTY DAMAGE MESSAGE.

GENERAL SAFETY PRECAUTIONS

WARNING!

READ MANUAL PRIOR TO INSTALLATION



Improper installation, operation, or maintenance of this equipment could result in serious injury or death. Operators and maintenance personnel should read this manual, as well as all manuals related to this equipment and the prime mover thoroughly before beginning installation, operation, or maintenance. **FOLLOW ALL SAFETY INSTRUCTIONS IN THIS MANUAL AND THE PRIME MOVER'S MANUAL(S).**



READ AND UNDERSTAND ALL SAFETY STATEMENTS

Read all safety decals and safety statements in all manuals prior to operating or working on this equipment. Know and obey all OSHA regulations, local laws, and other professional guidelines for your operation. Know and follow good work practices when assembling, maintaining, repairing, mounting, removing, or operating this equipment.



KNOW YOUR EQUIPMENT

Know your equipment's capabilities, dimensions, and operations before operating. Visually inspect your equipment before you start, and never operate equipment that is not in proper working order with all safety devices intact. Check all hardware to ensure it is tight. Make certain that all locking pins, latches, and connection devices are properly installed and secured. Remove and replace any damaged, fatigued, or excessively worn parts. Make certain all safety decals are in place and are legible. Keep decals clean, and replace them if they become worn or hard to read.

GENERAL SAFETY PRECAUTIONS

WARNING!



PROTECT AGAINST FLYING DEBRIS

Always wear proper safety glasses, goggles, or a face shield when driving pins in or out, or when any operation causes dust, flying debris, or any other hazardous material.

WARNING!



LOWER OR SUPPORT RAISED EQUIPMENT

Do not work under raised booms without supporting them. Do not use support material made of concrete blocks, logs, buckets, barrels, or any other material that could suddenly collapse or shift positions. Make sure support material is solid, not decayed, warped, twisted, or tapered. Lower booms to ground level or on blocks. Lower booms and attachments to the ground before leaving the cab or operator's station.

WARNING!



USE CARE WITH HYDRAULIC FLUID PRESSURE

Hydraulic fluid under pressure can penetrate the skin and cause serious injury or death. Hydraulic leaks under pressure may not be visible. Before connecting or disconnecting hydraulic hoses, read your prime mover's operator's manual for detailed instructions on connecting and disconnecting hydraulic hoses or fittings.

- Keep unprotected body parts, such as face, eyes, and arms as far away as possible from a suspected leak. Flesh injected with hydraulic fluid may develop gangrene or other permanent disabilities.
- If injured by injected fluid, see a doctor at once. If your doctor is not familiar with this type of injury, ask him to research it immediately to determine proper treatment.
- Wear safety glasses, protective clothing, and use a piece of cardboard or wood when searching for hydraulic leaks. **DO NOT USE YOUR HANDS!** **SEE ILLUSTRATION.**

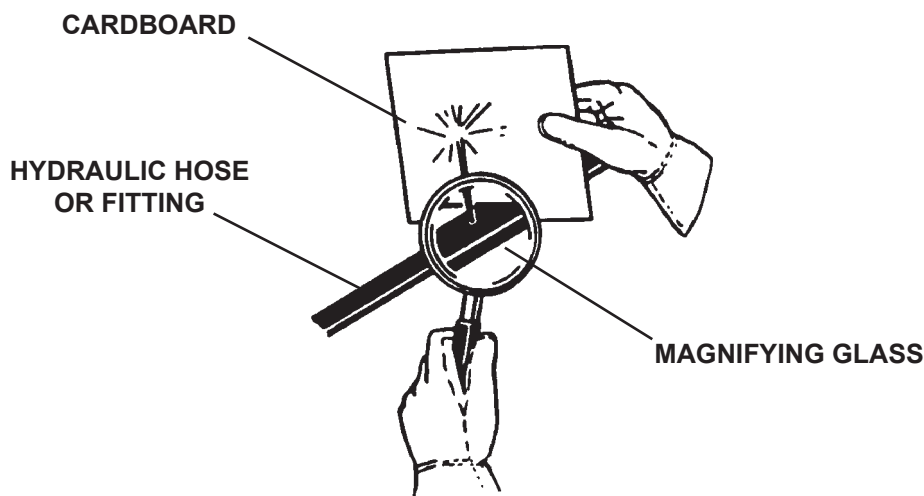

GENERAL SAFETY PRECAUTIONS

WARNING!



DO NOT MODIFY MACHINE OR ATTACHMENTS

Modifications may weaken the integrity of the attachment and may impair the function, safety, life, and performance of the attachment. When making repairs, use only the manufacturer's genuine parts, following authorized instructions. Other parts may be substandard in fit and quality. Never modify any ROPS (Roll Over Protection Structure) or FOPS (Falling Object Protective Structure) equipment or device. Any modifications must be authorized in writing by the manufacturer.

WARNING!



SAFELY MAINTAIN AND REPAIR EQUIPMENT

- Do not wear loose clothing or any accessories that can catch in moving parts. If you have long hair, cover or secure it so that it does not become entangled in the equipment.
- Work on a level surface in a well-lit area.
- Use properly grounded electrical outlets and tools.
- Use the correct tools for the job at hand. Make sure they are in good condition for the task required.
- Wear the protective equipment specified by the tool manufacturer.



SAFELY OPERATE EQUIPMENT

Do not operate equipment until you are completely trained by a qualified operator in how to use the controls, know its capabilities, dimensions, and all safety requirements. See your machine's manual for these instructions.

- Keep all step plates, grab bars, pedals, and controls free of dirt, grease, debris, and oil.
- Never allow anyone to be around the equipment when it is operating.
- Do not allow riders on the attachment or the prime mover.
- Do not operate the equipment from anywhere other than the correct operator's position.
- Never leave equipment unattended with the engine running, or with this attachment in a raised position.
- Do not alter or remove any safety feature from the prime mover or this attachment.
- Know your work site safety rules as well as traffic rules and flow. When in doubt on any safety issue, contact your supervisor or safety coordinator for an explanation.

EQUIPMENT SAFETY PRECAUTIONS

WARNING!



KNOW WHERE UTILITIES ARE

Observe overhead electrical and other utility lines. Be sure equipment will clear them. When digging, call your local utilities for location of buried utility lines, gas, water, and sewer, as well as any other hazard you may encounter.

WARNING!



EXPOSURE TO RESPIRABLE CRYSTALLINE SILICA DUST ALONG WITH OTHER HAZARDOUS DUSTS MAY CAUSE SERIOUS OR FATAL RESPIRATORY DISEASE.

It is recommended to use dust suppression, dust collection and if necessary personal protective equipment during the operation of any attachment that may cause high levels of dust.

WARNING!



REMOVE PAINT BEFORE WELDING OR HEATING

Hazardous fumes/dust can be generated when paint is heated by welding, soldering or using a torch. Do all work outside or in a well ventilated area and dispose of paint and solvent properly. Remove paint before welding or heating.

When sanding or grinding paint, avoid breathing the dust. Wear an approved respirator. If you use solvent or paint stripper, remove stripper with soap and water before welding. Remove solvent or paint stripper containers and other flammable material from area. Allow fumes to disperse at least 15 minutes before welding or heating.

WARNING!



END OF LIFE DISPOSAL

At the completion of the useful life of the unit, drain all fluids and dismantle by separating the different materials (rubber, steel, plastic, etc.). Follow all federal, state and local regulations for recycling and disposal of the fluid and components.



OPERATING THE ATTACHMENT

- Block off work area from bystanders, livestock, etc. Flying debris can cause severe injury or death. The brush cutter is capable of producing large amounts of flying debris in all directions.
- Let others know when and where you will be working. Make sure no one is behind the equipment or for several hundred feet in any direction around the equipment when in operation. Never allow anyone to approach the brush cutter when in operation.
- Do not raise the attachment when the blades are rotating.
- Do NOT operate without a shatterproof (demolition) cab door or front shield installed on the prime mover.
- Operate only from the operator's station.
- Do not exceed rated operating capacity of prime mover.
- Be sure all covers, front deflector chains and lift limiting chain(s) are properly installed before operating unit.
- When mounted onto a loader, do not operate the brush cutter with the back of the attachment over 12" above the ground.
- Do not lift loads in excess of the capacity of the prime mover. Lifting capacity decreases as the loader is moved further away from the unit.
- Never try to board or exit equipment while it is running.
- Test all controls before you begin operation.

EQUIPMENT SAFETY PRECAUTIONS



OPERATING THE ATTACHMENT

- When operating on slopes, drive up and down, not across. Avoid steep hillside operation, which could cause the prime mover to overturn.
- Reduce speed when driving over rough terrain, on a slope, or turning, to avoid overturning the vehicle.
- An operator must not use drugs or alcohol, which can change his or her alertness or coordination. An operator taking prescription or over-the-counter drugs should seek medical advice on whether or not he or she can safely operate equipment.
- Never leave the attachment unattended when in the raised position. Always make sure both skids are on the ground, parking brake is engaged, engine is turned off and the keys are removed before exiting the prime mover.



TRANSPORTING THE ATTACHMENT

- Travel only with the attachment in a safe transport position to prevent uncontrolled movement. Drive slowly over rough ground and on slopes.
- When transporting on a trailer: Secure attachment using tie down accessories that are capable of maintaining attachment stability.
- Use extra care when loading or unloading the attachment onto a truck or trailer. Disconnect hydraulic couplers during transporting when installed on prime mover.
- When driving on public roads use safety lights, reflectors, Slow Moving Vehicle signs etc., to prevent accidents. Check local government regulations that may affect you.
- Do not drive close to ditches, excavations, etc., cave in could result.
- Do not smoke when refueling the prime mover. Allow room in the fuel tank for expansion. Wipe up any spilled fuel. Secure cap tightly when done.



MAINTAINING THE ATTACHMENT

- Before performing maintenance, disengage auxiliary hydraulics, lower the attachment to the ground, turn off the engine, remove the key and apply the brakes. Be sure all rotation has stopped before making any adjustments or repairs.
- Never perform any work on the attachment unless you are authorized and qualified to do so. Always read the operator manual's before any repair is made. After completing maintenance or repair, check for correct functioning of the attachment. If not functioning properly, always tag "DO NOT OPERATE" until all problems are corrected.
- If attachment must be left raised for maintenance or any other reason, block the unit securely to prevent accidental release of the lifting mechanism. Serious damage or personal injury could result.
- Worn, damaged, or illegible safety decals must be replaced. New safety decals can be ordered from BRADCO.
- Never make hydraulic repairs while the system is under pressure. Serious personal injury or death could result.
- Never work under a raised attachment.

DECALS

DECAL PLACEMENT

GENERAL INFORMATION

The diagram on this page shows the location of all the decals used on your attachment. The decals are identified by their part numbers, with reductions of the actual decals located on the following pages. Use this information to order replacements for lost or damaged decals. Be sure to read all decals before operating the attachment. They contain information you need to know for both safety and backhoe longevity.

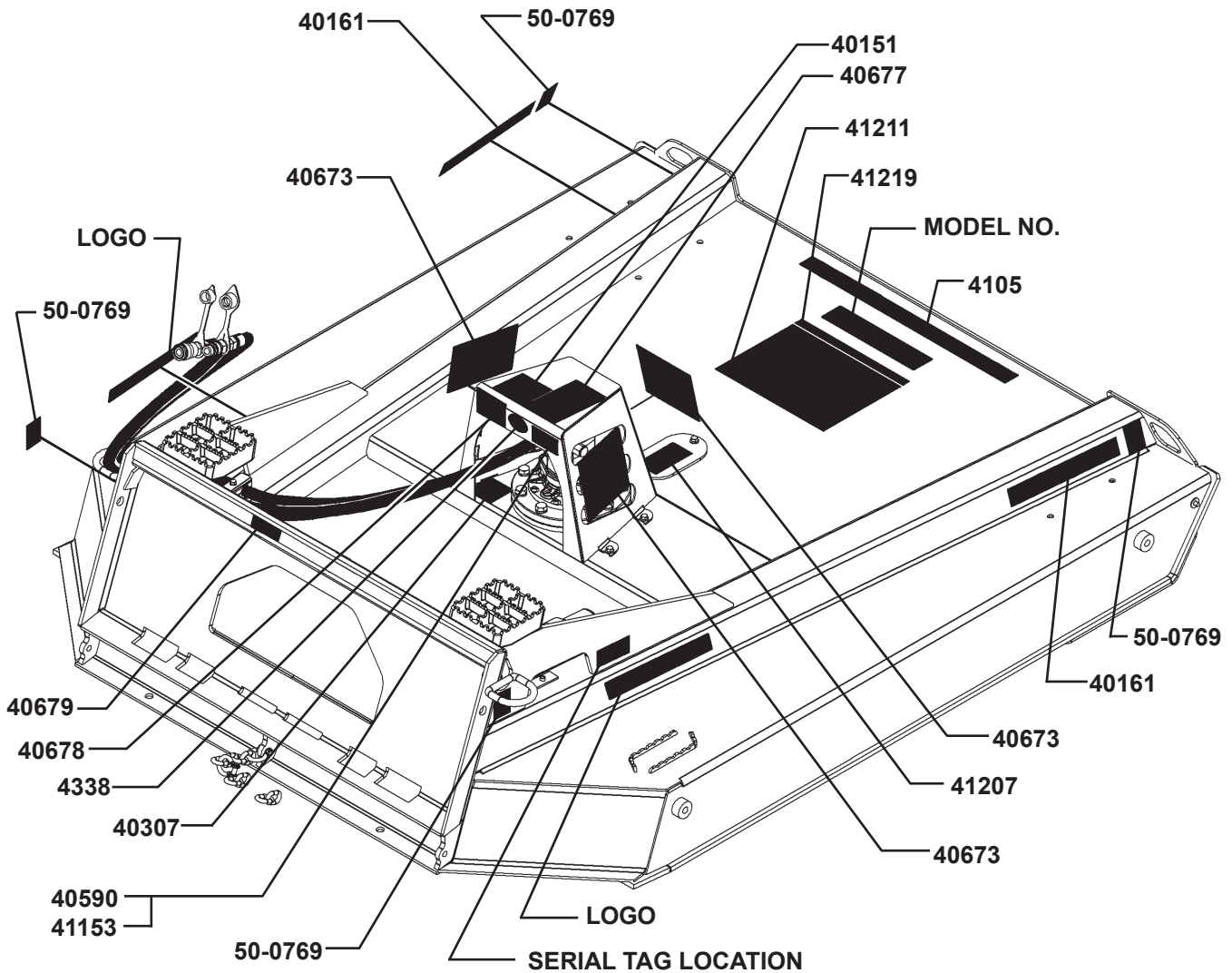

IMPORTANT: Keep all safety decals clean and legible. Replace all missing, illegible, or damaged safety decals. When replacing parts with safety decals attached, the safety decals must also be replaced. Safety decals are available, free of charge, from your local dealer or Paladin.

REPLACING SAFETY DECALS: Clean the area of application with nonflammable solvent, then wash the same area with soap and water. Allow the surface to fully dry. Remove the backing from the safety decal, exposing the adhesive surface. Apply the safety decal to the position shown in the diagram above and smooth out any bubbles.

DECALS



DANGER! ROTATING BLADE
PART #40673



WARNING! HIGH PRESSURE FLUID
PART #40151



DANGER! GUARD MISSING
PART #40307

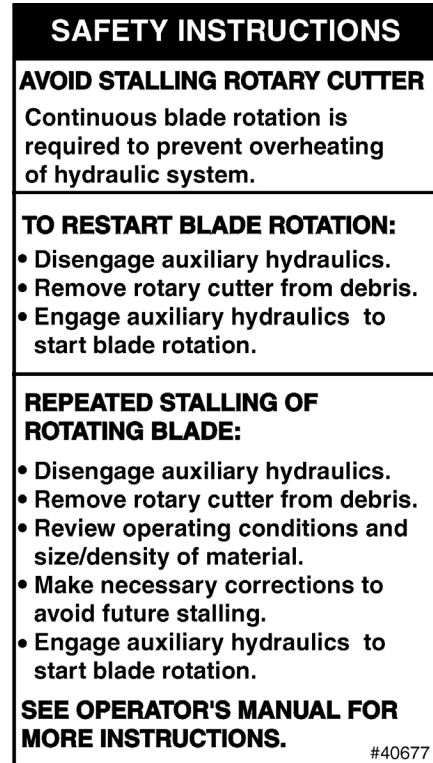

SAFETY INSTRUCTIONS
PART #40677

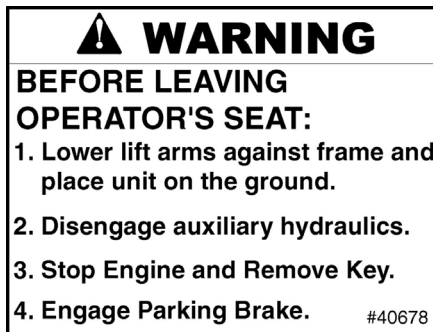

WARNING! BEFORE LEAVING OPERATOR'S SEAT
PART #40678



WARNING! LIFT LIMITING CHAIN
PART #40679

DECALS

DANGER STAND CLEAR

DANGER STAND CLEAR
PART #4105



CAUTION! MAX FLOW 25 GPM
(USED ON "A" SERIES UNITS ONLY)
PART #40590

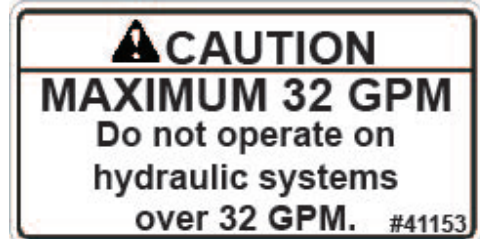

CAUTION! MAX FLOW 32 GPM
(USED ON "B" SERIES UNITS ONLY)
PART #41153



MADE IN USA
PART #4338

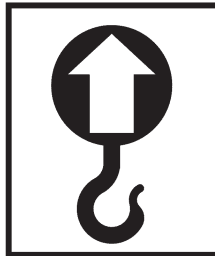

LIFT POINT
PART #50-0769



GROUND SHARK
PART #41211



WARNING! MOVING PARTS
PART #41207

STANDARD DUTY BRUSH CUTTER

STANDARD DUTY BRUSH CUTTER
PART #41219

STAND CLEAR

STAND CLEAR
PART #40161

NOTE: CONTACT YOUR LOCAL DEALER TO PURCHASE MODEL NUMBER AND LOGO DECALS.

PREOPERATION

GENERAL INFORMATION

Your attachment is operated by the prime mover's auxiliary hydraulics and mounts to the toolbar/quick attach mechanism for easy operator hook-up.

Your skid steer loader must have an auxiliary hydraulic system and a shatterproof door or front shield to operate the brush cutter.

DANGER! To avoid personal injury or death: The brush cutter must not be attached to any prime mover that does not have a shatterproof door or front shield installed.



WARNING! To avoid personal injury or death: Verify that you have the correct brush cutter for the GPM of your prime mover.



NOMENCLATURE

The purpose of these diagrams is to acquaint you with the various names of the brush cutter components. This knowledge will be helpful when reading through this manual or when ordering service parts.

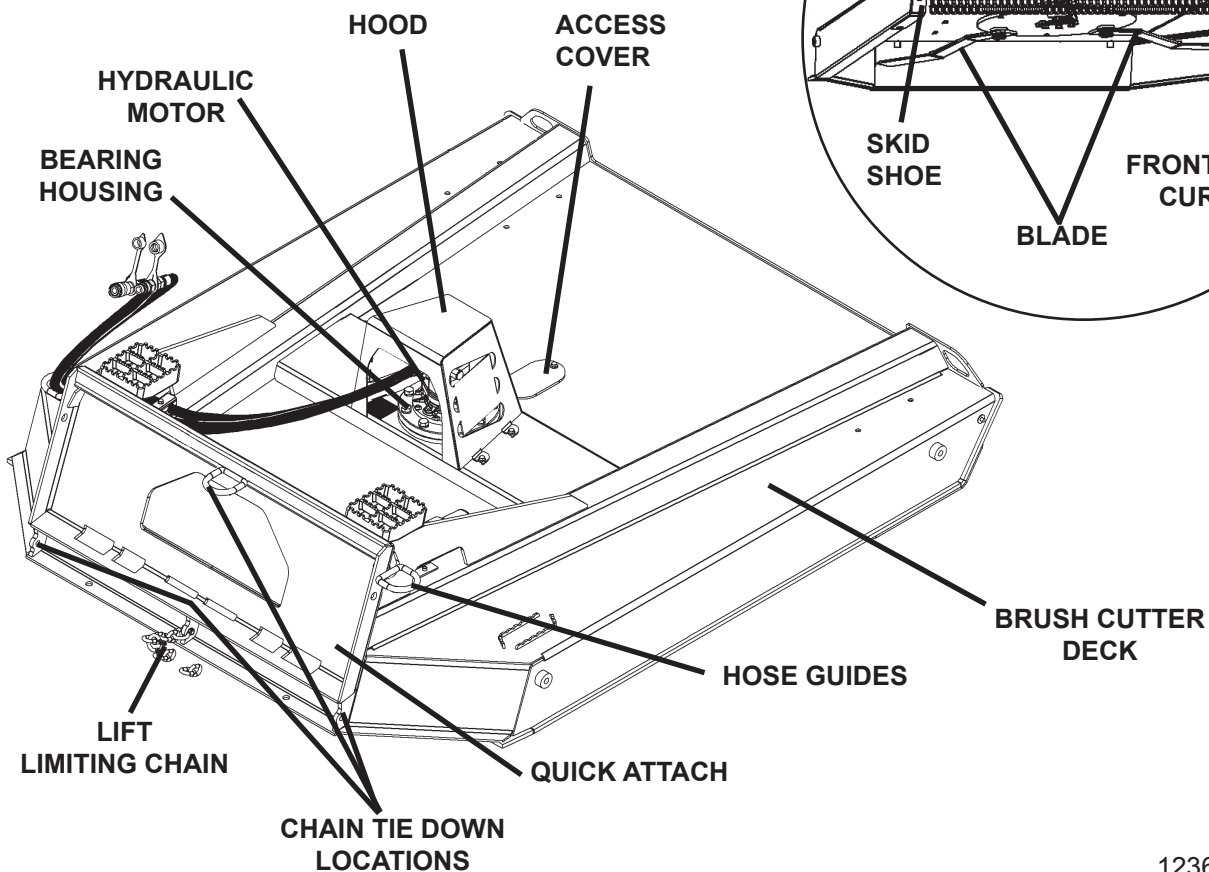

12368 5-21-13

INSTALLATION

GENERAL INFORMATION

The following instructions will help you to mount your brush cutter onto your prime mover. The brush cutter uses the quick-attach system for ease of installation. Therefore, if you know how to attach your loader bucket, attaching the brush cutter should prove no problem.

Remember to read all safety warnings, decals and operating instructions before operating the attachment. If there is any portion of this manual that you do not understand, contact your dealer.

DANGER! To avoid serious personal injury or death: The brush cutter must not be attached to any prime mover that does not have a shatterproof door or front shield installed.



WARNING! Operating the standard flow brush cutter on a high flow hydraulic system may cause severe injury or death to the operator or bystanders due to the increased RPM. Verify that you have the correct brush cutter for the GPM of your prime mover.



ATTACHING TO PRIME MOVER

NOTE: Before attaching the brush cutter to your loader, make sure a shatterproof door (or front shield) has been installed onto the front of your prime mover.

1. Remove any attachments from the front of the loader.
2. Following all standard safety practices and the instructions for installing an attachment in your prime mover operator's manual, install the brush cutter onto your prime mover's loader.

NOTE: It is important to make sure the locking mechanism on your quick attach is engaged, therefore locking the attachment onto the prime mover.

3. Connect the Lift Limiting Chain to the front of your loader. The back of the brush cutter should never be more than 1 foot off the ground for proper and safe cutting.

(Raise the unit to 1 foot above ground level. Route the Lift Limiting Chain from the back of the brush cutter, through the tie down mechanism(s) on the front of your loader and back to either the "D" ring/keyslot on the top of the universal mount (A) or to the chain tie down locations on the bottom of the universal mount (B). Tie the chain securely back to itself with the shackle provided, to limit the lifting capabilities of the cutter to 1 foot maximum.)

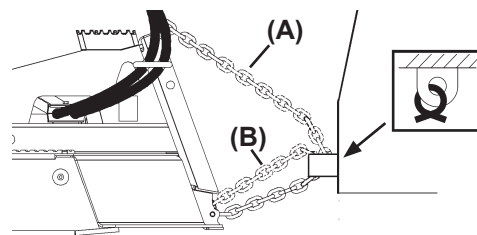

4. Lower the unit to the ground and remove the key.
5. After making sure that there is not any foreign matter on the hydraulic couplers, connect the couplers to the auxiliary hydraulic system of your prime mover.

DETACHING FROM PRIME MOVER

1. On firm, level ground, lower the attachment so both skids are on the ground, parking brake is engaged, engine is turned off and the keys are removed.
2. Follow your prime mover operator's manual to relieve pressure in the hydraulic lines.
3. Disconnect couplers and either connect them together or install dust caps and plugs to prevent contaminants from entering the hydraulic system. Store hoses on attachment, off the ground.
4. Follow your prime mover operator's manual for detaching (removing) an attachment.

OPERATION

INTENDED USE: The Ground Shark Standard Duty Brush Cutter is designed for cutting tall grass, brush and small trees up to 4" (102mm) in diameter while still maintaining a 12" (305mm) maximum ground clearance. Use in any other way is considered contrary to its intended use.

GENERAL INFORMATION

The Ground Shark Standard Duty Brush Cutter attaches to the toolbar/quick-attach mechanism of your prime mover. Due to this arrangement, thorough knowledge of the prime mover controls is necessary for machine operation. Read and understand your prime mover operator's manual for information regarding prime mover operation before attempting to use the brush cutter.

Follow all installation instructions for the proper installation of the unit onto your prime mover before attempting to operate your brush cutter.

OPERATING TIPS

- If your preferred direction of blade rotation is not set up correctly for your prime mover's "detent", the hydraulic hoses may be reversed at the motor end.
- Engage and disengage the hydraulic system with the prime mover at idle.
- Continuous rotation of the blade is required to prevent overheating of the hydraulic system. Blade rotation is maintained by monitoring the system pressure and oil temperature on your prime mover and operating the attachment at pressures below relief valve settings.

NOTE: Overheating of the hydraulic system is caused if hydraulic oil is repeatedly forced over the relief valve setting on either the prime mover or brush cutter (whichever is less). Taking note of the maximum pressure gauge reading when the system goes over relief on your application (prime mover and brush cutter combination) and then careful monitoring of the pressure gauge on the brush cutter (if so equipped) will help you prevent repeatedly forcing your unit to go over relief and therefore causing overheating of the hydraulic system and also stalling of the blade carrier.

- Increase the life of your bi-directional blades by cutting brush in one direction and cutting grass and smaller vegetation in the other. (This will keep the blades sharp for cutting grass.)

DANGER! ROTATING BLADE HAZARD! STAY BACK!



OBJECTS CAN BE THROWN!

DO NOT operate near bystanders.

DO NOT place hands or feet under deck while in operation or with engine running.

DO NOT operate without a shatterproof door (or front shield) installed on loader.

OPERATION

WARNING!  Before leaving the operator's seat: Lower the lift arms against frame and place both skid shoes on the ground. Disengage auxiliary hydraulics. Stop Engine. Engage parking brake. Remove the key.

WARNING! Lift limiting chain must be properly installed before operation.

WARNING!  Operating the standard flow brush cutter on a high flow hydraulic system may cause severe injury or death to the operator or bystanders due to the increased RPM. Verify that you have the correct brush cutter for the GPM of your prime mover.

CUTTING OPERATION

1. Raise the back of the unit off of the ground approximately 4" (102mm) to allow the material to clear from under the cutting deck as you travel forward.
2. Place the front skid shoes 1"-2" (25-51mm) off the ground. This is the preferred position for cutting grass and heavy vegetation.
 - Never drive your prime mover with the front of the brush cutter tilted to the point your view is obstructed. Always make sure you can see what you are cutting.
 - Check the work area. Never operate the brush cutter in populated areas where thrown objects could injure persons or damage property.
 - Never raise the unit and expose yourself or anyone else to the rotating blades. If you can see the blades then the back of the unit is raised too high. Maximum ground clearance at any time is 12" (305mm).
3. Activate the auxiliary hydraulics with the engine at idle. Increase engine speed.
4. Be sure the brush cutter is operating smoothly and at full speed, and then start forward travel while monitoring pressure and temperature gauges to ensure blade rotation.

CUTTING LARGE BRUSH AND TREES UP TO 3"-4" (76-102mm) IN DIAMETER:

1. Roll the front only of the brush cutter up 1-2 feet (305-610mm). **DO NOT LIFT THE BACK OF THE CUTTER!**
2. Slowly drive into the tree and use the hydraulic tilt function on the prime mover to bend or push the tree over. As the tree bends, the blades will cut it off.
3. The tree can now be mulched by rotating the front up, drive forward several feet, roll the front down onto the tree and back drag. Repeat, if necessary. Remember do not lift the back of the cutter.

AVOID STALLING BRUSH CUTTER: Continuous rotation is required to prevent overheating of the hydraulic system "SEE OPERATING TIPS". If the brush cutter stalls, see "TO RESTART BLADE ROTATION".

OPERATION

TO RESTART BLADE ROTATION: Return engine speed to idle and disengage auxiliary hydraulics. Remove brush cutter from debris. Engage auxiliary hydraulics to start blade rotation. (Be sure the brush cutter is operating smoothly and at full speed, then start forward travel while monitoring system pressure and temperature.)

REPEATED STALLING OF ROTATING BLADES: Return the engine speed to idle and disengage auxiliary hydraulics. Remove brush cutter from debris. Review operating conditions and the size/density of material being cut. Make necessary corrections. Engage auxiliary hydraulics to start blade rotation. (Be sure the brush cutter is operating smoothly and at full speed, and then start forward travel while monitoring system pressure and temperature.)

TROUBLESHOOTING OPERATING CONDITIONS:

Below are listed a few operating conditions that may cause repeated stalling of your brush cutter, and suggestions on how to correct them.

GRASS TOO LONG OR THICK: If cutting heavy vegetation, you may need to slow travel speed or make smaller passes (less than full cut) to prevent overloading and stalling the unit.

BRUSH TOO BIG IN DIAMETER: The brush cutter is NOT designed to cut trees larger than 3"-4" (76-102mm) in diameter. If brush is smaller than 3"-4" (76-102mm) in diameter and the cutter is stalling, check sharpness of the blades (see "Maintenance") and cut using the procedure described earlier in this section for "CUTTING LARGE BRUSH AND SMALL TREES".

BRUSH TOO THICK OR HEAVY: If cutting heavy or thick brush, you may need to slow travel speed or make smaller passes (less than full cut), to prevent overloading. If the blades seem to be unable to handle the volume of brush, slow down the travel speed until the unit reaches full speed before proceeding.

SCALPING THE GROUND or BOTTOMING OUT: Be aware of changes in the terrain. Stay alert for drop-off's and holes. Check the terrain and the deck position before restarting and continuing cutting.

STRIKING FOREIGN OBJECTS: Stay alert for rocks, fencing, abandoned wells, septic tanks or other foreign objects. If the brush cutter comes into contact with a foreign object, stop the unit, shut off the engine and disconnect the hydraulic couplers from the prime mover. Inspect the unit and repair any damage before restarting and continuing cutting. (Never try to weld or straighten damaged blades.) Inspect the work area for any other items, and if they are too large to be removed from the area, they should be clearly flagged.

OPERATING INSTRUCTIONS

STORAGE

The following storage procedure will help you to keep your attachment in top condition. It will also help you get off to a good start the next time your brush cutter is needed. We therefore strongly recommend that you take the extra time to follow these procedures whenever your unit will not be used for an extended period of time.

- Clean the unit thoroughly, removing all mud, dirt, and grease.
- Sharpen or replace blades. Replace all blades at the same time and do not try to weld or straighten damaged blades; loss of integrity may result.
- Inspect for visible signs of wear, breakage, or damage. Order any parts required, and make the necessary repairs to avoid delays when starting next season. **NOTE: Purchase only approved replacement parts.**
- Tighten all loose nuts, capscrews, and hydraulic connections.
- Check the drive bearing housing for proper lubricant level.
- Seal hydraulic system from contaminants and secure all hydraulic hoses off the ground to help prevent damage.
- Replace decals if damaged, or in unreadable condition.
- Apply a rust-preventive spray to all moving parts and to the bottom of the deck.
- Store the unit in a dry and protected place. Leaving the unit outside will materially shorten its life.

Additional Precautions for Long Term Storage:

- Touch up all unpainted and exposed areas with paint, to prevent rust.

REMOVING FROM STORAGE

- Remove all protective coverings.
- Check hydraulic hoses for deterioration, and replace if necessary.
- Check all nuts and bolts for proper tightness, especially those securing the motor, bearing housing and blades.

LIFT POINTS

Lifting points are identified by lifting decals where required. Lifting at other points is unsafe and can damage attachment. Do not attach lifting accessories around cylinders or in any way that may damage hoses or hydraulic components. See Diagram

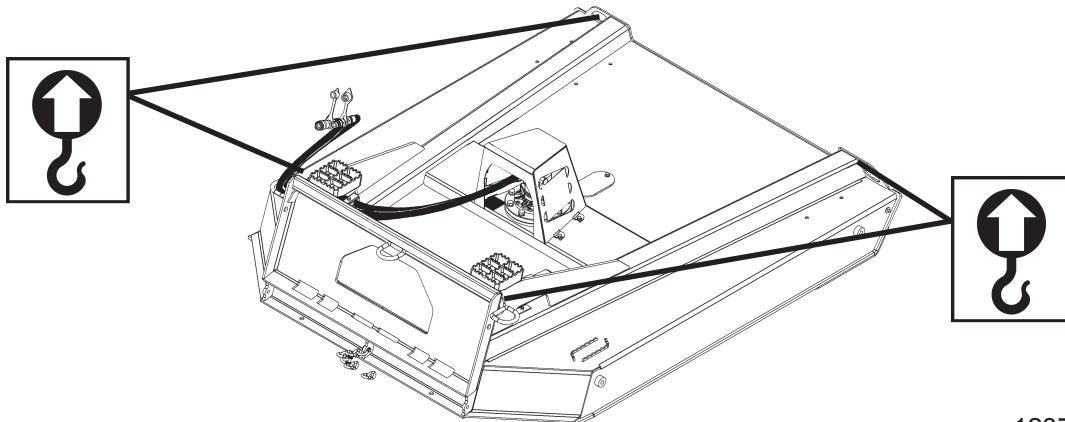

12373 4-15-13

OPERATING INSTRUCTIONS

- Attach lifting accessories to unit at recommended lifting points.
- Bring lifting accessories together to a central lifting point.
- Lift gradually, maintaining the equilibrium of the unit.

WARNING! Use lifting accessories (chains, slings, ropes, shackles and etc.) that are capable of supporting the size and weight of your attachment. Secure all lifting accessories in such a way to prevent unintended disengagement. Failure to do so could result in the attachment falling and causing serious personal injury or death.



TIE DOWN POINTS

Tie down points are identified by tie down decals where required. Securing to trailer at other points is unsafe and can damage attachment. Do not attach tie down accessories around cylinders or in any way that may damage hoses or hydraulic components. See Diagram

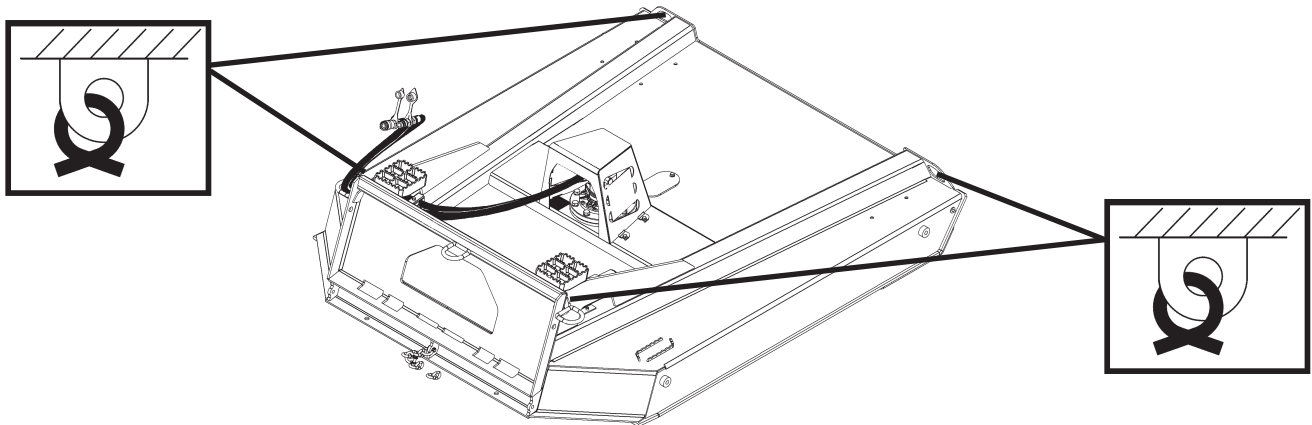

- Attach tie down accessories to unit as recommended.
- Check unit stability before transporting.

WARNING! Verify that all tie down accessories (chains, slings, ropes, shackles and etc.) are capable of maintaining attachment stability during transporting and are attached in such a way to prevent unintended disengagement or shifting of the unit. Failure to do so could result in serious personal injury or death.



TRANSPORTING

Follow all local government regulations that may apply along with recommended tie down points and any equipment safety precautions at the front of this handbook when transporting your attachment.

LUBRICATION

GENERAL INFORMATION

Economical and efficient operation of any machine is dependent upon regular and proper lubrication of all moving parts with a quality lubricant. Neglect leads to reduced efficiency, wear, breakdown, and needless replacement of parts.

WEEKLY

The oil level in the drive bearing housing should be checked once a week. Fill as necessary with a mild extreme pressure lubricant API-GL-5, No. 80 or 90 weight gear lubricant. Oil Capacity is approximately 10 oz (.3 liters).

TO CHECK:

Remove plug from front of drive bearing housing. Lubricant should be visible and just covering the top bearings. Do Not OVERFILL.

TO ADD:

Remove plug from end of front of the drive bearing housing and add lubricant until top bearings are covered. Replace plug.

DRIVE BEARING HOUSING

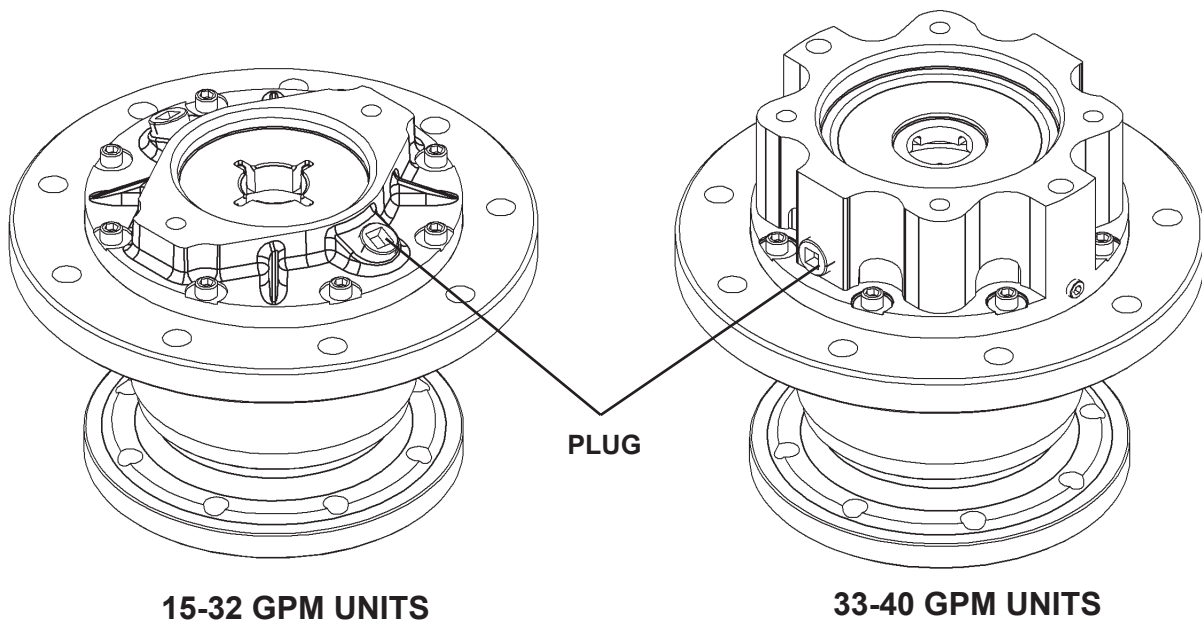

MAINTENANCE

GENERAL INFORMATION

Regular maintenance is the key to long equipment life and safe operation. Maintenance requirements have been reduced to an absolute minimum. However, it is very important that these maintenance functions be performed as described.

WARNING!  **Avoid serious injury. Lower the brush cutter so both skid shoes are on the ground, set the parking brake, stop the skid steer engine, and remove the key before leaving the operator's seat. If unit must be left raised for maintenance, block the unit securely to prevent accidental release of the lifting mechanism. Disconnect the hydraulic couplers.**

PROCEDURE	DAILY	EVERY 40 HOURS	1200 HOURS
Check skid steer loader hydraulic system to ensure an adequate level of hydraulic oil.	✓		
Check mounting hardware on blades and tighten if necessary. See Bolt Torque Specifications.	✓		
Check all other hardware and tighten, if necessary. See Bolt Torque Specifications.	✓		
Check hydraulic system for hydraulic oil leaks.	✓		
Check blades for damage and replace or sharpen as needed.	✓		
Check all safety guards and ensure that all devices are installed correctly.	✓		
Check for missing or illegible Safety / Warning Decals.	✓		
Check oil level in drive bearing housing and add if necessary.		✓	
Change oil in drive bearing housing.			✓

WARNING!  **Escaping fluid under pressure can have sufficient force to penetrate the skin, causing serious personal injury. Fluid escaping from a very small hole can be almost invisible. Use a piece of cardboard or wood, rather than hands to search for suspected leaks.**

Keep unprotected body parts, such as face, eyes, and arms as far away as possible from a suspected leak. Flesh injected with hydraulic fluid may develop gangrene or other permanent disabilities.

If injured by injected fluid, see a doctor at once. If your doctor is not familiar with this type of injury, ask him to research it immediately to determine proper treatment.

MAINTENANCE

WARNING! Avoid serious injury. Lower the brush cutter to the ground, set the parking brake, stop the prime mover engine, and remove the key before leaving the operator's seat. If unit must be left raised for maintenance, block the unit securely to prevent accidental release of the lifting mechanism. Disconnect the hydraulic couplers.



REPLACING BLADES

When replacing, or sharpening the blades, the unit must be blocked securely off the ground to gain access to the blades.

The blades should be inspected regularly (every 8 hours) to ensure they are sharp, tightened correctly, and intact. Always replace all three blades at the same time and NEVER try to weld or straighten damaged blades, as loss of blade integrity may result.

Removing Blades:

1. With unit securely blocked off the ground and hydraulic couplers disconnected, loosen the capscrews on the blade access cover and swing cover open. See Figure #1

FIGURE #1

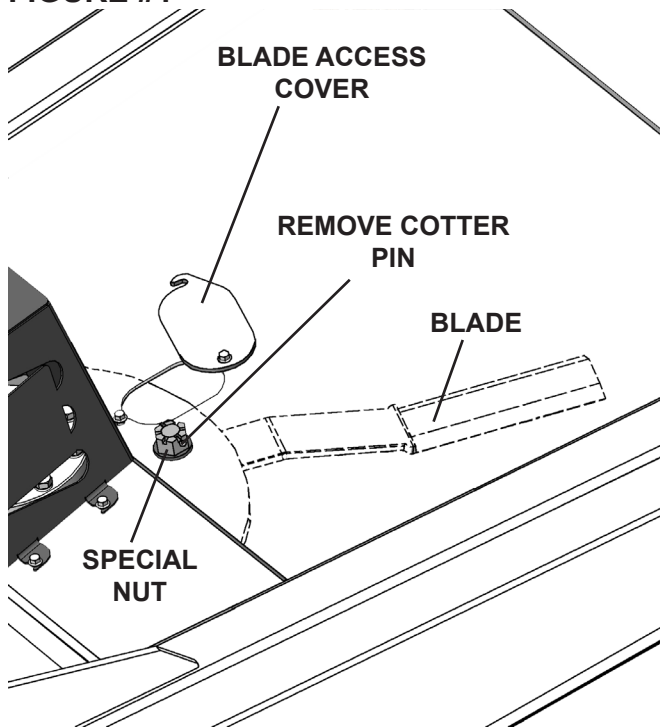

2. Position one of the blades under the access panel and remove the cotter pin and special nut. You can now remove the blade mounting bolt and the blade.
3. Repeat step #2 for the remaining blades.

Installing Blades:

1. With unit securely blocked off the ground and hydraulic couplers disconnected, loosen the capscrews on the blade access cover and swing cover open.
2. Position the blade with the key of the mounting bolt in alignment with the key way, and either prop up in place or have an assistant hold in place while the special nut is installed onto the bolt through the blade access panel. Torque nut to 450 ft. lbs. and install cotter pin.
3. Repeat step #1 and #2 for the remaining blades.

MAINTENANCE

WARNING!  Avoid serious injury. Lower the brush cutter to the ground, set the parking brake, stop the prime mover engine, and remove the key before leaving the operator's seat. If unit must be left raised for maintenance, block the unit securely to prevent accidental release of the lifting mechanism. Disconnect the hydraulic couplers.

REPLACING HYDRAULIC MOTOR

When replacing the hydraulic motor the unit should be setting firmly on the ground with the hydraulic couplers disconnected. **Be sure all rotation has stopped before making any adjustments or repairs.**

NOTE: Field replacement of the internal motor seals voids warranty.

1. Remove motor cover. (Loosen (4) capscrews and slide cover forward. Capscrews do not need to be removed.)
2. Tag and remove hydraulic hoses from existing hydraulic motor.

IMPORTANT: If couplers were not disconnected prior to removing the hoses, oil will drain from the skid steer causing extensive oil loss.

3. Remove the motor from the drive bearing housing. Check motor seal for damage and replace if required.

NOTE: If motor shaft seal was damaged you will need to drain the existing oil from the drive bearing housing and replace with new before installing the new motor. See instructions for Changing Oil in Drive Bearing Housing.

4. Grease the new motor spline shaft and install the new motor with o'ring onto the drive bearing housing (through pressure gauge mounting if so equipped) using the existing hardware and Loctite 592. Torque to specifications. See Bolt Torque Specifications.
5. Re-install hoses.
6. Re-install cover (place to front of capscrews and slide cover under the head of the capscrews). Torque to specification. See Bolt Torque Specifications.

FIGURE #2

TAG HYDRAULIC HOSES

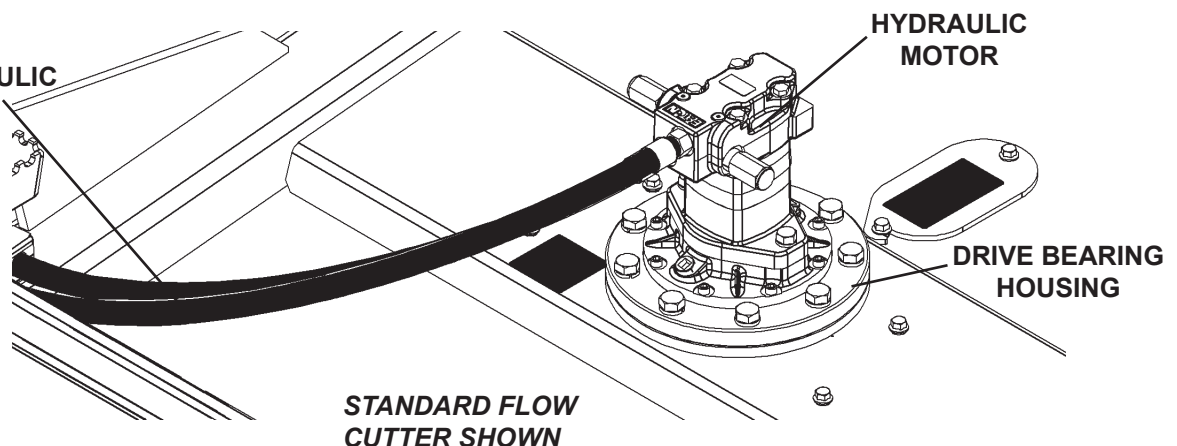

MAINTENANCE

WARNING!  Avoid serious injury. Lower the brush cutter to the ground, set the parking brake, stop the prime mover engine and remove the key before leaving the operator's seat. If unit must be left raised for maintenance, block the unit securely to prevent accidental release of the lifting mechanism. Disconnect the hydraulic couplers.

REPLACING DRIVE BEARING HOUSING

When replacing the drive bearing housing, the unit must be detached from the prime mover in a clean, open location with a hoist available that has adequate lift capacity for lifting the attachment. **Be sure all rotation has stopped before making any adjustments or repairs.**

1. With the unit disconnected from the prime mover, attach a hoist to the two front lift locations and slowly lift the brush cutter and place it upside down with the blade carrier exposed.

NOTE: Block the unit in such a fashion that it is not resting on the motor or hood.

NOTE: Be prepared for possible shifting of the brush cutter as it clears the ground. Block the cutter, if required, to ensure it is completely stable before proceeding.

2. Remove the eight .62" capscrews securing the drive bearing housing to the blade carrier. See Figure #3

FIGURE #3

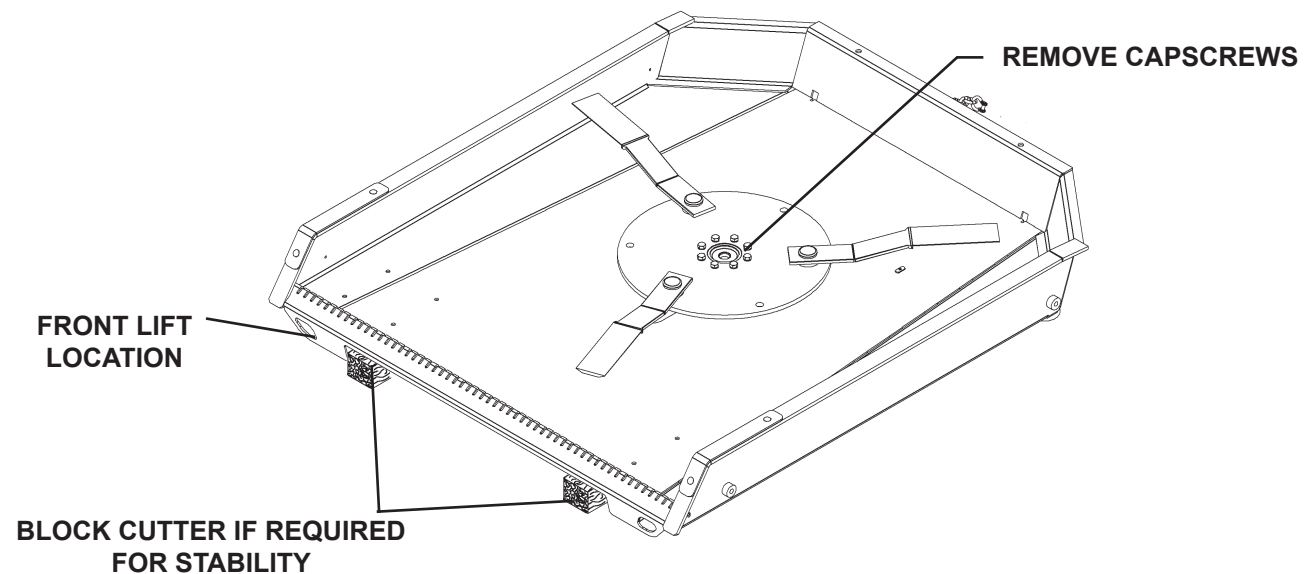

3. Attach the hoist to the blade carrier assembly and set aside. (**NOTE: The blade carrier weighs approximately 155 lbs (70.3 kgs).**)
4. With the blade carrier assembly removed. Attach the hoist onto the front lifting holes and set the unit back onto the skid shoes.

MAINTENANCE

5. Remove motor cover. (Loosen (4) capscrews and slide cover forward. Capscrews do not need to be removed.)
6. Remove the capscrews holding the motor to the drive bearing housing, and remove the motor and pressure gauge (if so equipped), setting it into a clean container to help prevent any contaminants from entering the hydraulic system. Check motor o'ring for damage and replace if required.
7. Remove the .62" capscrews securing the drive bearing housing to the cutter deck and install new housing using the existing hardware. Torque to specification. See Bolt Torque Specifications
8. Remove plugs from top of housing and fill with a mild extreme pressure lubricant API-GL-5, No. 80 or 90 weight gear lubricant just until bearings are covered. Do Not Overfill. Replace plugs.
9. Grease the hydraulic motor spline shaft and install the motor assembly, o'ring and pressure gauge (if so equipped) onto the drive bearing housing using the existing hardware and Loctite 592.
10. Re-install cover (place to front of capscrews and slide cover under the head of the capscrews). Torque to specification. See Bolt Torque Specifications.
11. Re-attach the hoist to the two front lift locations on the push bar and slowly lift the brush cutter and place it upside down.

NOTE: Be prepared for possible shifting of the cutter as it is clears the ground. Block the cutter, if required to ensure it is completely stable before proceeding.

12. Attach the hoist to the blade carrier assembly and set it into place aligning the holes on the blade carrier to the ones on the bearing housing. **(NOTE: The blade carrier weighs approximately 155 lbs (70.3 kgs).**
13. Reinstall the eight .62" capscrews and washers securing the drive bearing housing to the blade carrier. Torque to specification. See Bolt Torque Specifications
14. Attach the hoist onto the front lifting holes on the push bar and set the unit back onto the skid shoes.

Follow the installation procedure for attaching the unit onto your prime mover.

MAINTENANCE

CHANGING OIL IN DRIVE BEARING HOUSING

When changing the oil in the drive bearing housing the unit should be setting firmly on the ground with the hydraulic couplers disconnected. We recommend removing the existing oil with a fluid removal pump.

1. Remove one of the plugs in the drive bearing housing and place the extraction hose into the housing so that it reaches the bottom.
2. Place the output hose into an approved container or drum that will hold the waste oil.
3. Following the instructions for your fluid removal pump, remove all oil from the drive bearing housing.
4. Once the oil has been drained from the housing, remove the pump and refill the housing with approximately 10 oz. (.3 liters) of a mild extreme pressure lubricant API-GL-5, No. 80 or 90 weight gear lubricant.

IMPORTANT: DO NOT OVERFILL.

5. Replace plug. Torque to specification. See Bolt Torque Specifications

DRIVE BEARING HOUSING

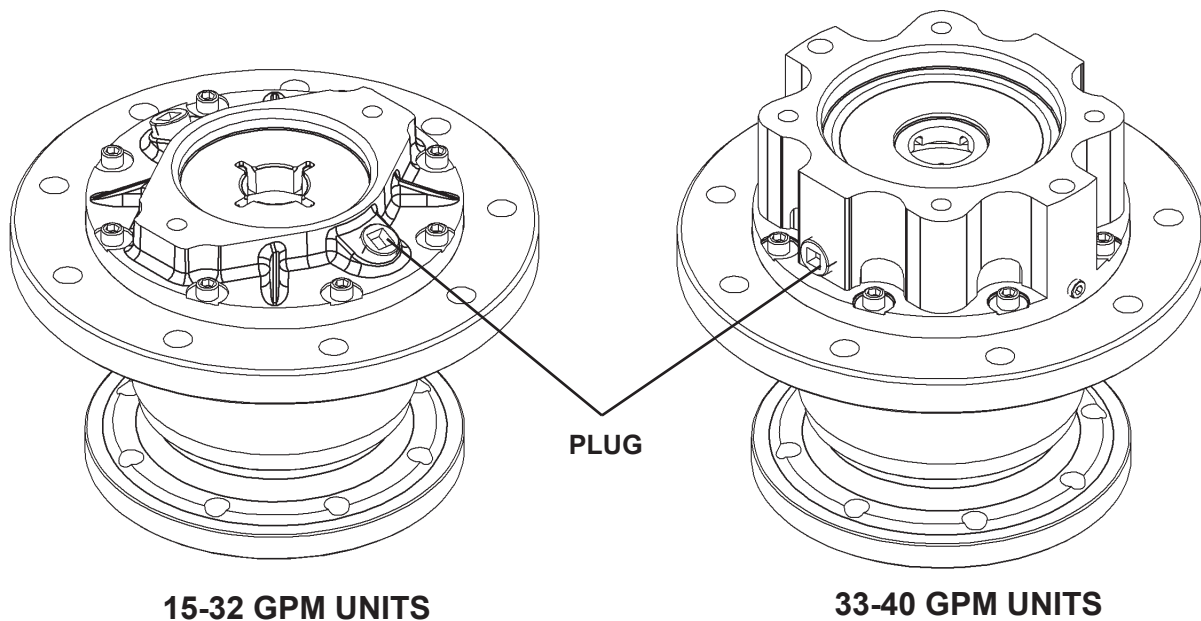

TROUBLESHOOTING

PROBLEM	POSSIBLE CAUSE	POSSIBLE SOLUTION
EXCESSIVE VIBRATION	Blades damaged or worn.	Replace worn blades as a set of three.
	Bearing failure. (To diagnose bearing failure; rotate blade carrier slowly and listen for bearing noise.)	Replace Drive Bearing Housing.
CUTTER STALLS TOO EASILY OR LOSS OF POWER	Power and return hoses reversed. (This unit will turn in reverse direction until placed under load, then hydraulic flow will bypass drive motor.)	Check flow direction and switch hydraulic couplers.
	Bearing failure. (To diagnose bearing failure; rotate blade carrier slowly and listen for bearing noise. Bearing failure will reduce power available to function correctly.)	Replace Drive Bearing Housing.
	Inadequate hydraulic flow from prime mover.	Check hydraulic flow to brush cutter.
	Couplers not engaged.	Engage couplers.
	Air in hydraulic lines.	Activate system until air is purged from hydraulic system.
	Damaged hose or obstruction in hydraulic lines.	Remove any obstruction and replace if necessary.
	Loose or damaged hydraulic connection.	Tighten or replace fitting.
	Hydraulic motor damaged or seal blown	Call Bradco service department for instructions.
LEAKING OIL	Loose or damaged hydraulic line.	Tighten or replace.
	Loose or missing bearing housing plug.	Tighten or replace.
	Hydraulic motor damaged or seal blown.	Call Bradco service department for instructions.
	Bearing housing damaged or seal blown.	Call Bradco service department for instructions.

SPECIFICATIONS

SPECIFICATIONS AND DESIGN ARE SUBJECT TO CHANGE WITHOUT NOTICE AND WITHOUT LIABILITY THEREFOR.

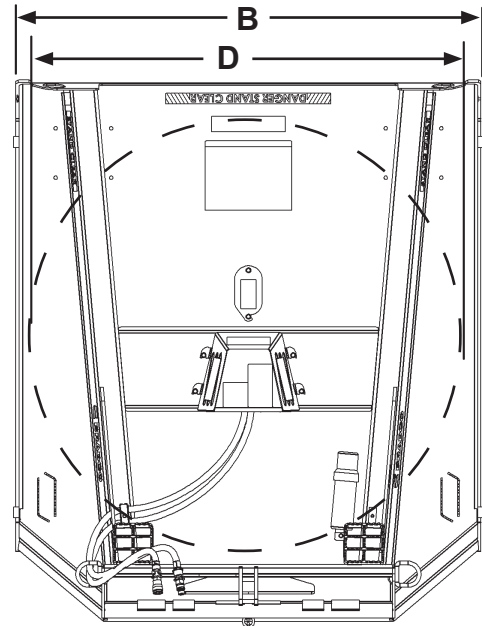
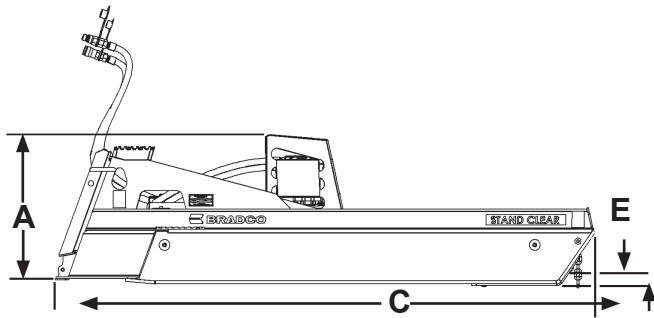

DESCRIPTION	A SERIES 15-25 GPM			B SERIES 26-32 GPM	
	GSS60	GSS72	GSS78	GSS72	GSS78
A. Overall Height	24.00"	24.00"	24.00"	24.00"	24.00"
B. Overall Width	64.00"	76.00"	82.00"	76.00"	82.00"
C. Overall Length	76.00"	88.00"	94.00"	88.00"	94.00"
D. Cutting Width	60.00"	72.00"	78.00"	72.00"	78.00"
E. Minimum Cutting Height 2.00" (Skid Shoes on Ground)	2.00"	2.00"	2.00"	2.00"	2.00"
Cutting Capacity (Max. Cutting Diameter)	4.00"	4.00"	4.00"	4.00"	4.00"
Deck Thickness	1/4" Steel	1/4" Steel	1/4" Steel	1/4" Steel	1/4" Steel
Recommended GPM	15-25	15-25	15-25	26-32	26-32
Required Skid Steer Lift Capacity	1200#	1400#	1500#	1400#	1500#
Weight	1120#	1280#	1360#	1280#	1365#

DESCRIPTION	C SERIES 33-40 GPM	
	GSS72	GSS78
A. Overall Height	27.00"	27.00"
B. Overall Width	76.00"	82.00"
C. Overall Length	88.00"	94.00"
D. Cutting Width	72.00"	78.00"
E. Minimum Cutting Height 2.00" (Skid Shoes on Ground)	2.00"	2.00"
Cutting Capacity (Max. Cutting Diameter)	4.00"	4.00"
Deck Thickness	1/4" Steel	1/4" Steel
Recommended GPM	33-40	33-40
Required Skid Steer Lift Capacity	1500#	1600#
Weight	1320#	1405#



BOLT TORQUE SPECIFICATIONS

GENERAL TORQUE SPECIFICATION TABLES

Use the following charts when determining bolt torque specifications when special torques are not given. Always use grade 5 or better when replacing bolts.



SAE BOLT TORQUE SPECIFICATIONS

NOTE: The following torque values are for use with extreme pressure lubricants, plating or hard washer applications. Increase torque 15% when using hardware that is unplated and either dry or lubricated with engine oil.

Bolt Size		SAE GRADE 5 TORQUE				SAE GRADE 8 TORQUE				Bolt head identification marks as per grade. NOTE: Manufacturing Marks Will Vary
		Pounds Feet		Newton-Meters		Pounds Feet		Newton-Meters		
Inches	Millimeters	UNC	UNF	UNC	UNF	UNC	UNF	UNC	UNF	
1/4	6.35	8	9	11	12	10	13	14	18	<p>GRADE 2</p>  <p>GRADE 5</p>  <p>GRADE 8</p> 
5/16	7.94	14	17	19	23	20	25	27	34	
3/8	9.53	30	36	41	49	38	46	52	62	
7/16	11.11	46	54	62	73	60	71	81	96	
1/2	12.70	68	82	92	111	94	112	127	152	
9/16	14.29	94	112	127	152	136	163	184	221	
5/8	15.88	128	153	174	207	187	224	254	304	
3/4	19.05	230	275	312	373	323	395	438	536	
7/8	22.23	340	408	461	553	510	612	691	830	
1	25.40	493	592	668	803	765	918	1037	1245	
1-1/8	25.58	680	748	922	1014	1088	1224	1475	1660	
1-1/4	31.75	952	1054	1291	1429	1547	1700	2097	2305	
1-3/8	34.93	1241	1428	1683	1936	2023	2312	2743	3135	
1-1/2	38.10	1649	1870	2236	2535	2686	3026	3642	4103	

METRIC BOLT TORQUE SPECIFICATIONS

NOTE: The following torque values are for use with metric hardware that is unplated and either dry or lubricated with engine oil. Reduce torque 15% when using hardware that has extreme pressure lubricants, plating or hard washer applications.

Bolt head identification marks as per grade.		
		

Size of Bolt	Grade No.	Pitch (mm)	Pounds Feet	Newton-Meters	Pitch (mm)	Pounds Feet	Newton-Meters
M6	5.6	1.0	3.6-5.8	4.9-7.9	-	-	-
	8.8		5.8-4	7.9-12.7		-	-
	10.9		7.2-10	9.8-13.6		-	-
M8	5.6	1.25	7.2-14	9.8-19	1.0	12-17	16.3-23
	8.8		17-22	23-29.8		19-27	25.7-36.6
	10.9		20-26	27.1-35.2		22-31	29.8-42
M10	5.6	1.5	20-25	27.1-33.9	1.25	20-29	27.1-39.3
	8.8		34-40	46.1-54.2		35-47	47.4-63.7
	10.9		38-46	51.5-62.3		40-52	54.2-70.5
M12	5.6	1.75	28-34	37.9-46.1	1.25	31-41	42-55.6
	8.8		51-59	69.1-79.9		56-68	75.9-92.1
	10.9		57-66	77.2-89.4		62-75	84-101.6
M14	5.6	2.0	49-56	66.4-75.9	1.5	52-64	70.5-86.7
	8.8		81-93	109.8-126		90-106	122-143.6
	10.9		96-109	130.1-147.7		107-124	145-168
M16	5.6	2.0	67-77	90.8-104.3	1.5	69-83	93.5-112.5
	8.8		116-130	157.2-176.2		120-138	162.6-187
	10.9		129-145	174.8-196.5		140-158	189.7-214.1
M18	5.6	2.0	88-100	119.2-136	1.5	100-117	136-158.5
	8.8		150-168	203.3-227.6		177-199	239.8-269.6
	10.9		175-194	237.1-262.9		202-231	273.7-313
M20	5.6	2.5	108-130	146.3-176.2	1.5	132-150	178.9-203.3
	8.8		186-205	252-277.8		206-242	279.1-327.9
	10.9		213-249	288.6-337.4		246-289	333.3-391.6

**THIS PAGE
IS INTENTIONALLY
BLANK**

Limited Warranty

Except for the Excluded Products as described below, all new products are warranted to be free from defects in material and/or workmanship during the Warranty Period, in accordance with and subject to the terms and conditions of this Limited Warranty.

1. Excluded Products. The following products are excluded from this Limited Warranty:

(a) Any cable, part that engages with the ground (i.e. sprockets), digging chain, bearing, teeth, tamping and/or demolition head, blade cutting edge, pilot bit, auger teeth and broom brush that either constitutes or is part of a product.

(b) Any product, merchandise or component that, in the opinion of Paladin Light Construction¹, has been (i) misused; (ii) modified in any unauthorized manner; (iii) altered; (iv) damaged; (v) involved in an accident; or (vi) repaired using parts not obtained through Paladin Light Construction.

2. Warranty Period. The Limited Warranty is provided only to those defects that occur during the Warranty Period, which is the period that begins on the first to occur of: (i) the date of initial purchase by an end-user, (ii) the date the product is first leased or rented, or (iii) the date that is six (6) months after the date of shipment by Paladin Light Construction as evidenced by the invoiced shipment date (the "Commencement Date") and ends on the date that is twelve (12) months after the Commencement Date.

3. Terms and Conditions of Limited Warranty. The following terms and conditions apply to the Limited Warranty hereby provided:

(a) Option to Repair or Replace. Paladin Light Construction shall have the option to repair or replace the product.

(b) Timely Repair and Notice. In order to obtain the Limited Warranty, (i) the product must be repaired within thirty (30) days from the date of failure, and (ii) a claim under the warranty must be submitted to Paladin Light Construction in writing within thirty (30) days from the date of repair.

(c) Return of Defective Part or Product. If requested by Paladin Light Construction, the alleged defective part or product shall be shipped to Paladin Light Construction at its manufacturing facility or other location specified by Paladin Light Construction, with freight PRE-PAID by the claimant, to allow Paladin Light Construction to inspect the part or product.

Claims that fail to comply with any of the above terms and conditions shall be denied.

LIMITATIONS AND EXCLUSIONS.

THIS LIMITED WARRANTY IS IN LIEU OF ALL OTHER WARRANTIES, EXPRESS OR IMPLIED, INCLUDING WITHOUT LIMITATION THE WARRANTIES OF MERCHANTABILITY, FITNESS FOR A PARTICULAR PURPOSE AND ANY WARRANTY BASED ON A COURSE OF DEALING OR USAGE OF TRADE.

IN NO EVENT SHALL PALADIN LIGHT CONSTRUCTION BE LIABLE FOR CONSEQUENTIAL OR SPECIAL DAMAGES.

IN NO EVENT SHALL PALADIN LIGHT CONSTRUCTION BE LIABLE FOR ANY LOSS OR CLAIM IN AN AMOUNT IN EXCESS OF THE PURCHASE PRICE, OR, AT THE OPTION OF PALADIN LIGHT CONSTRUCTION, THE REPAIR OR REPLACEMENT, OF THE PARTICULAR PRODUCT ON WHICH ANY CLAIM OF LOSS OR DAMAGE IS BASED. THIS LIMITATION OF LIABILITY APPLIES IRRESPECTIVE OF WHETHER THE CLAIM IS BASED ON BREACH OF CONTRACT, BREACH OF WARRANTY, NEGLIGENCE OR OTHER CAUSE AND WHETHER THE ALLEGED DEFECT IS DISCOVERABLE OR LATENT.

¹Attachment Technologies Inc., a subsidiary of Paladin Brands Holding, Inc. (PBHI) is referred to herein as Paladin Light Construction.

**THIS PAGE
IS INTENTIONALLY
BLANK**

PARTS

In order to provide you with the most UP-TO-DATE part information all parts for this attachment have been moved to our website at www.paladinattachments.com/Manuals. Please use these diagrams and parts lists to locate replacement parts.

When servicing your attachment, remember to use only original manufacturer replacement parts. Substitute parts may not meet the standards required for safe, dependable operation.

To facilitate parts ordering when contacting the factory, please have the product control number (PCN) or model and serial number of your product ready to ensure that you receive the correct parts for your specific attachment.

The product control number (PCN), model and serial number for your attachment should be recorded in the space provided on the cover of this manual. This information may be obtained from the serial number identification plate located on your attachment.

NOTE: Most daily and emergency parts orders (in stock) received by 10:30 A.M. (Eastern Standard Time) will be shipped UPS Ground the same day received. UPS Next Day orders must be received by 1:30 PM (Eastern Standard Time.)

SERVICE DEPARTMENT

(734) 996-9116

(800) 456-7100

We Encourage Fax and E-mail Orders

PLC_Sales@paladinattachments.com

(734) 996-9014