



# OPERATOR'S & PARTS MANUAL

## 2625, 3625 & 4425 TREE SPADES



**PALADIN**  
LIGHT CONSTRUCTION GROUP



*The Power of Combined Excellence*

ALL  
APPLICATIONS



SERIAL NUMBER: \_\_\_\_\_

MODEL NUMBER: \_\_\_\_\_

Manual Number: OM679  
Part Number: 75579  
Rev. 2



---

# TABLE OF CONTENTS

---

<b>TO THE OWNER .....</b>	<b>A</b>
<b>SAFETY PRECAUTIONS .....</b>	<b>B</b>
To the Operator	
Before You Start	
Working With The Attachment	
Transporting The Attachment	
Maintenance	
<b>INTERNATIONAL SYMBOLS .....</b>	<b>C</b>
<b>PRE-OPERATION .....</b>	<b>D</b>
Before Operating	
Blade Preparation	
Skid-Steer or Host Machine	
Major Nomenclature	
<b>MOUNTING KITS AND ASSEMBLIES .....</b>	<b>E</b>
2625 Tree Spade	
3625 Tree Spade	
4425 Tree Spade	
Hydraulic Circuits	
Cylinder Assemblies	
Electrical Assembly	
Valve Assembly	
Solenoid Valve - Replacement Parts	
Wiring Schematics	
<b>INSTALLATION INSTRUCTIONS .....</b>	<b>F</b>
<b>OPERATION INSTRUCTIONS .....</b>	<b>G</b>
Controls	
General Information	
Adjusting Leg Height	
Balled and Burlapped Trees	
Direct Transplanting	
<b>LUBRICATION .....</b>	<b>H</b>
<b>MAINTENANCE AND SERVICE .....</b>	<b>L</b>
Preventive Maintenance	
Blade Maintenance	
Sharpening Blades and Undercutter	
Replacing Bushings	
Slide Channel Adjustment	
Cylinder Seal Replacement	
<b>STORAGE AND TRANSPORTING .....</b>	<b>M</b>
<b>TROUBLESHOOTING .....</b>	<b>N</b>
<b>BOLT TORQUE SPECIFICATION .....</b>	<b>O</b>
<b>SPECIFICATIONS .....</b>	<b>P</b>
<b>DECALS .....</b>	<b>Q</b>
<b>PREDELIVERY CHECKLIST .....</b>	<b>R</b>
<b>LIMITED WARRANTY .....</b>	<b>S</b>

**THIS PAGE  
IS INTENTIONALLY  
BLANK**

---

## TO THE OWNER

---

### GENERAL COMMENTS

Congratulations on the purchase of your new BRADCO product! This product was carefully designed and manufactured to give you years of dependable service. Only minor maintenance (such as cleaning and lubricating) is required to keep it in top working condition. Be sure to observe all safety precautions and maintenance procedures, as described in this manual.

### ABOUT THIS MANUAL

This manual has been designed to help you do a better, safer job. Read this manual carefully and become familiar with its contents. **Remember, never let anyone operate this unit without reading the "Safety Precautions" and "Operating Instructions" sections of this manual. (See Sections B and G respectively.)**

Unless noted otherwise, right and left sides are determined from the position of the operator when behind the product facing forward.

### SAFETY ALERT SYMBOL



This is the "Safety Alert Symbol" used by this industry. This symbol is used to warn of possible injury. Be sure to read all warnings carefully. They are included for your safety and for the safety of others working with you.

### SERVICE

When servicing your product, remember to use only manufacturer replacement parts. Substitute parts may not meet the standards required for safe, dependable operation.

To facilitate parts ordering, record the model and serial number of your unit in the space provided on this page. This information may be obtained from the identification plate located on the product.

**MODEL** \_\_\_\_\_  
**SERIAL NUMBER** \_\_\_\_\_  
**DATE PURCHASED** \_\_\_\_\_

The parts department needs this information to insure that you receive the correct parts for your specific model.

**THIS PAGE  
IS INTENTIONALLY  
BLANK**

## SAFETY PRECAUTIONS

TAKE NOTE! THIS SAFETY ALERT SYMBOL FOUND THROUGHOUT THIS MANUAL IS USED TO CALL YOUR ATTENTION TO INSTRUCTIONS INVOLVING YOUR PERSONAL SAFETY OR OTHERS. FAILURE TO FOLLOW THESE INSTRUCTIONS CAN RESULT IN INJURY OR DEATH.



**THIS SYMBOL MEANS:**

**ATTENTION!**

**BECOME ALERT!**

**YOUR SAFETY IS INVOLVED!**

**SIGNAL WORDS:** Note the use of signal words DANGER, WARNING, and CAUTION with the safety messages. The appropriate signal word for each has been selected using the following guidelines:

**DANGER:** Indicates an imminently hazardous situation, which if not avoided, will result in death or serious injury. This signal word is to be limited to the most extreme situations, **typically for machine components which, for functional purposes, cannot be guarded.**

**WARNING:** Indicates a potentially hazardous situation, which if not avoided, could result in death or serious injury, and **includes hazards that are exposed when guards are removed. It may also be used to alert against unsafe practices.**

**CAUTION:** Indicates a potentially hazardous situation, which if not avoided, **may result in minor or moderate injury. It may also be used to alert against unsafe practices.**

## SAFETY PRECAUTIONS

### GENERAL INFORMATION

This section is composed of various warnings and safety tips. **Read and learn all the information in this section before you attempt to use your attachment.** Also read your vehicle owner's manual before using your equipment. This knowledge will help you operate your unit safely. **Do not take this information lightly, it is presented for your benefit and for the benefit of others working around you.**

The "Safety Alert Symbol", as previously described, will be used throughout this manual. It will appear with the word **DANGER, WARNING, or CAUTION** above it, and a safety message pertaining to the specific topic being covered. Take the time to read these messages as you come across them.

### TO THE OPERATOR

The primary responsibility for safety with the equipment falls to the operator. Make sure that the equipment is operated only by responsible individuals with the proper instruction. It is the skill, care, common sense, and good judgment of the operator that will determine how efficiently and safely the job is performed. Know your equipment before you start. Know its capabilities and how to operate all the controls. Visually inspect your equipment before you start, and never operate equipment that is not in proper working order.

### BEFORE YOU START

1. **Read the entire loader and attachment operator's manuals** before ever attempting to use the loader. This knowledge is necessary for safe operation.
2. **Follow all safety decals.** Keep them clean, and replace them if they become worn, damaged, or illegible.
3. **Do not paint over,** remove, or deface any safety signs or warning decals on your equipment.
4. **Know your equipment inside and out.** Know how to operate all controls, and know emergency shut down procedures.
5. **Keep all stepping surfaces, pedals, and controls free from dirt, grease, and oil.** Keep equipment clean to help avoid injury from a fall when getting on or off equipment.
6. **Use handholds and step plates when getting on/off .** Failure to do so could cause a fall.
7. **Be alert to others in the work area.** Be sure others know when and where you will be working. Make sure no one is behind equipment.
8. **Never take passengers on your equipment.** There is no safe place for a passenger.



## SAFETY PRECAUTIONS

9. **Never try to board equipment while it is moving.**
10. **Turn off engine before performing maintenance.** If lift arms must be left raised for maintenance or any other reason, use a positive lift arm lock to secure the arms in place. Serious damage or personal injury could result from lift arms accidentally lowering.
11. **Reduce speed when driving over rough terrain,** on a slope, or turning, to avoid overturning the loader.
12. **Test all controls before you begin.**
13. **Do not smoke when refueling.** Allow room in the gas tank for expansion. Wipe up any spilt fuel. Secure cap tightly when done.

### WORKING WITH THE ATTACHMENT

1. **Never operate the unit without first reading and understanding the operator's manual.**
2. **Operate the attachment only in daylight or sufficient artificial light.**
3. **Do not carry load with arms in the raised position.** Always carry loads close to the ground. Do not step off platform with load raised.
4. **Check your work area, and know where all utility lines are.** Avoid hitting underground electrical wires, cables, pipes, fence posts, gas lines, uneven sidewalk edges, large rocks, etc.
5. **Never operate equipment while under the influence** of alcohol or prescription drugs, which could inhibit physical and/or mental capacity.
6. **Do not exceed rated operating capacity, as machine may become unstable, which may result in loss of control.**
7. **Slow down before turning.** Sharp turns on any terrain may cause loss of control.
8. **Always lower the loader arms to the ground,** shut off the engine, and remove the key before getting off the unit.

### TRANSPORTING THE ATTACHMENT

1. **Follow all federal, state, and local regulations when transporting the unit on public roads.**
2. **Use extra care when loading or unloading the machine onto a trailer or truck.**

### MAINTENANCE

1. **Never work on equipment while it is running.**
2. **Never make hydraulic repairs while the system is under pressure.** Injury or death could result.

## SAFETY PRECAUTIONS

3. **Observe proper maintenance schedules** and repairs to keep the unit in safe working order.
4. **Always wear safety goggles or glasses when working on equipment.**
5. **Use a drift and hammer when pressing out pins,** to prevent the pin from shattering.
6. **Use only manufacturer recommended replacement parts.** Other parts may be substandard in fit and quality.

### **WARNING!**



Escaping fluid under pressure can have sufficient force to penetrate the skin, causing serious personal injury. Fluid escaping from a very small hole can be almost invisible. Use a piece of cardboard or wood, rather than hands, to search for suspected leaks.

Keep unprotected body parts, such as face, eyes, and arms as far away as possible from a suspected leak. Flesh injected with hydraulic fluid may develop gangrene or other permanent disabilities.

If injured by injected fluid, see a doctor at once. If your doctor is not familiar with this type of injury, ask him to research it immediately to determine proper treatment.

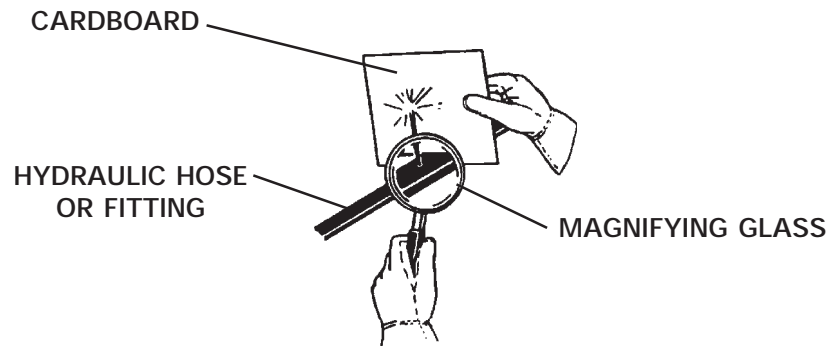

## INTERNATIONAL SYMBOLS

As a guide to the operation of your equipment, various international symbols have been utilized on the instruments and controls. The symbols are shown below with an indication of their meaning.

	Engine speed		Alternator charge
	Hours recorded		Power take-off (on)
	Engine water temperature		Power take-off (off)
	Lights		"Tortoise," slow or minimum setting
	Horn		"Hare," fast or maximum setting
	Engine oil pressure		Caution
	Hazard warning		Control lever operating direction
	Axle connect		Rock shaft (raised)
	Axle disconnect		Rock shaft (lowered)
	Continuously variable		Remote cylinder (extended)
	Increase		Remote cylinder (retracted)
	Decrease		Remote cylinder (FLOAT)
	Diesel fuel		Differential lock
	Creeper range		Read operators manual
	High range		Neutral
	Low range		Forward
			Reverse

---

## PRE-OPERATION

---

### GENERAL INFORMATION

The purpose of this manual is to assist in setting up, operating and maintaining your **BRADCO** Tree Spade. Read it carefully. It furnishes information and instructions that will help you achieve years of dependable performance.

Unless noted otherwise, right and left are determined from the position of the operator sitting in the operator's seat facing forward.

Remember to read the "Safety Precautions" and "Operating Instructions" sections of this manual BEFORE you attempt to operate the attachment.

**NOTE: The illustrations and data used in this manual were current (according to the information available to us) at the time of printing, however, we reserve the right to redesign and change the tree spade as may be necessary without notification.**

### BEFORE OPERATION

The primary responsibility for safety with this equipment falls to the operator. Make sure that the equipment is operated only by trained individuals that have read and understand this manual. Don't hurry the learning process or take the unit for granted. Practice the operation of your new equipment and become familiar with the controls and the way it handles on your machine.

### SKID-STEER OR OTHER HOST MACHINE

The BRADCO Tree Spades mount to various host machines such as, but not limited to skid-steers, loaders, tractors and excavators. Due to the quantity of skid-steer applications, we will be referring to the host machine as a skid-steer loader throughout this manual.

The skid-steer must have front auxiliary hydraulics and a 12 Volt DC electrical power source available for spade operation. The **BRADCO** Tree Spades are NOT designed for use on high flow skid-steers.

Rear stabilizers are recommended to get the maximum performance of your tree spade. The rear stabilizers allow as much weight as possible to be transferred to the front of the skid-steer and therefore to the tree spade for maximum digging ability.

---

**PRE-OPERATION**

---

**MAJOR NOMENCLATURE**

Throughout this manual, reference is made to various attachment components. The purpose of this section is to acquaint you with the various names of these components. This knowledge will be helpful when reading through the manual or when ordering service parts.

The blades are identified in a clockwise direction starting with the left rear spade.

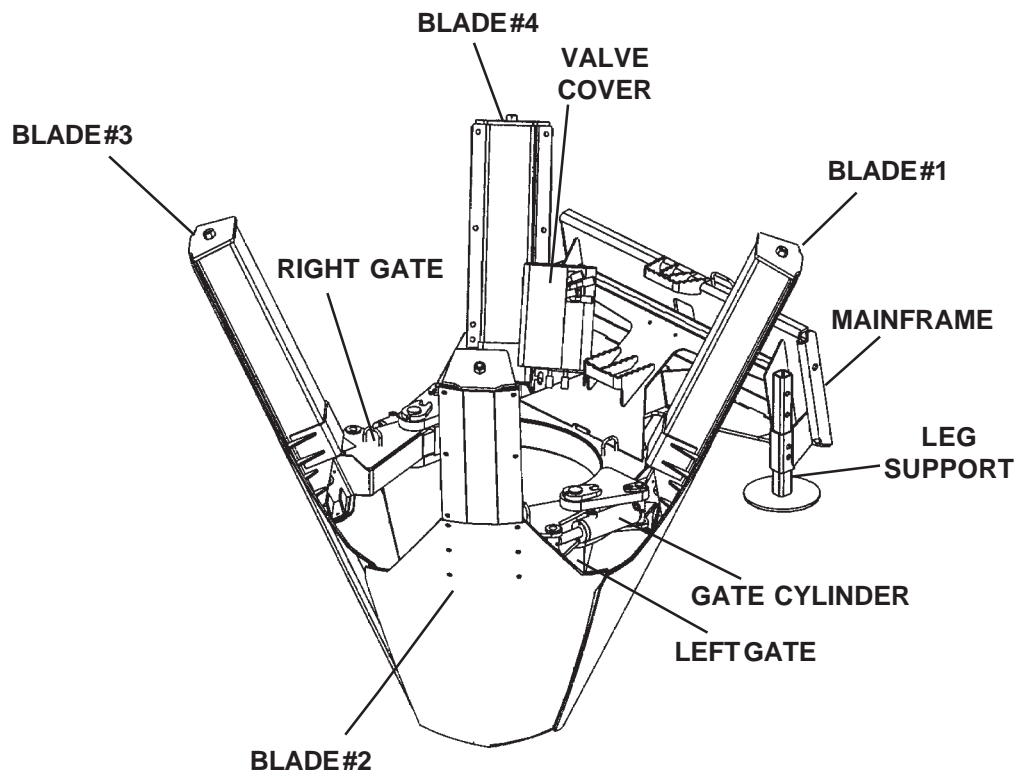
**Model 4425 Tree Spade shown**

# 2625 TREE SPADE

ASSEMBLY #25670

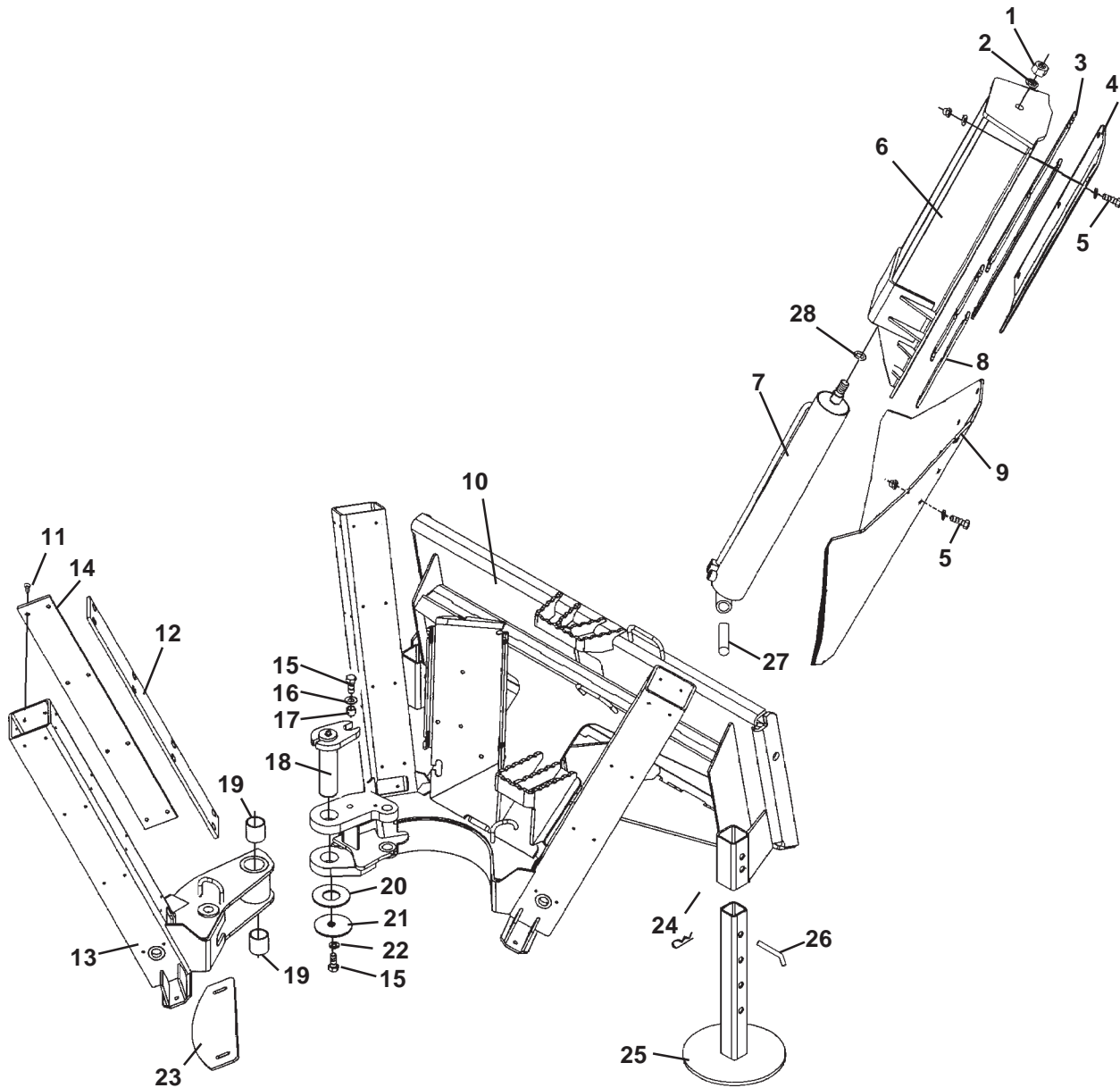

# 2625 TREE SPADE

ASSEMBLY #25670

<u>NO</u>	<u>REQ'D</u>	<u>PART NO.</u>	<u>DESCRIPTION</u>
1	3	1483	1.00" UNF Deformed Lock Nut
2	3	1706	1.00" Hard Flat Washer
3	12	25661	Shim
4	3	25664	Tower Cover
5	36	1841	.50" UNC Deformed Lock Nut
	48	1646	.50" Hard Flat Washer
	12	1090	.50 UNC X 1.50" Hex Capscrew
	24	1781	.50 UNC X 2.00" Hex Capscrew (Blades) GR 8
6	3	25671	Tower
7	3	25660	Cylinder Assembly - Blades
8	12	25662	Shim
9	3	25669	Blade
10	1	25667	Mainframe
11	96	10082	.31" UNC X .62" Flathead Capscrew
12	3	25665	Wear Plate 3.50" X 27"
13	1	25668	Arm
14	9	25666	Wear Plate 3.50" X 30"
15	2	1114	.62" UNC X 1.50" Hex Capscrew
16	1	1627	.62" Hard Flat Washer
17	1	25075	Spacer
18	1	25358	Pivot Pin
	1	6616	Grease Fitting
19	2	6356	Replacement Bushing (Included with Arm Weldment)
20	As Req'd	6622	Thrust Washer
21	1	25132	Special Washer (.69" X 2.50" X .38")
22	1	1506	.62" Lock Washer
23	3	25663	Scraper Plate
	6	1044	.38" UNC X 1.25" Hex Capscrew
	6	1800	.38" Hard Flat Washer
	6	1837	.38" UNC Deformed Lock Nut
24	2	1860	Hair Pin
25	2	25144	Leg
26	2	89951	Hlitch Pin (Includes Hair Pin)
27	3	25672	Pin
28	3	5421	Washer

# 2625 TREE SPADE

ASSEMBLY #25670

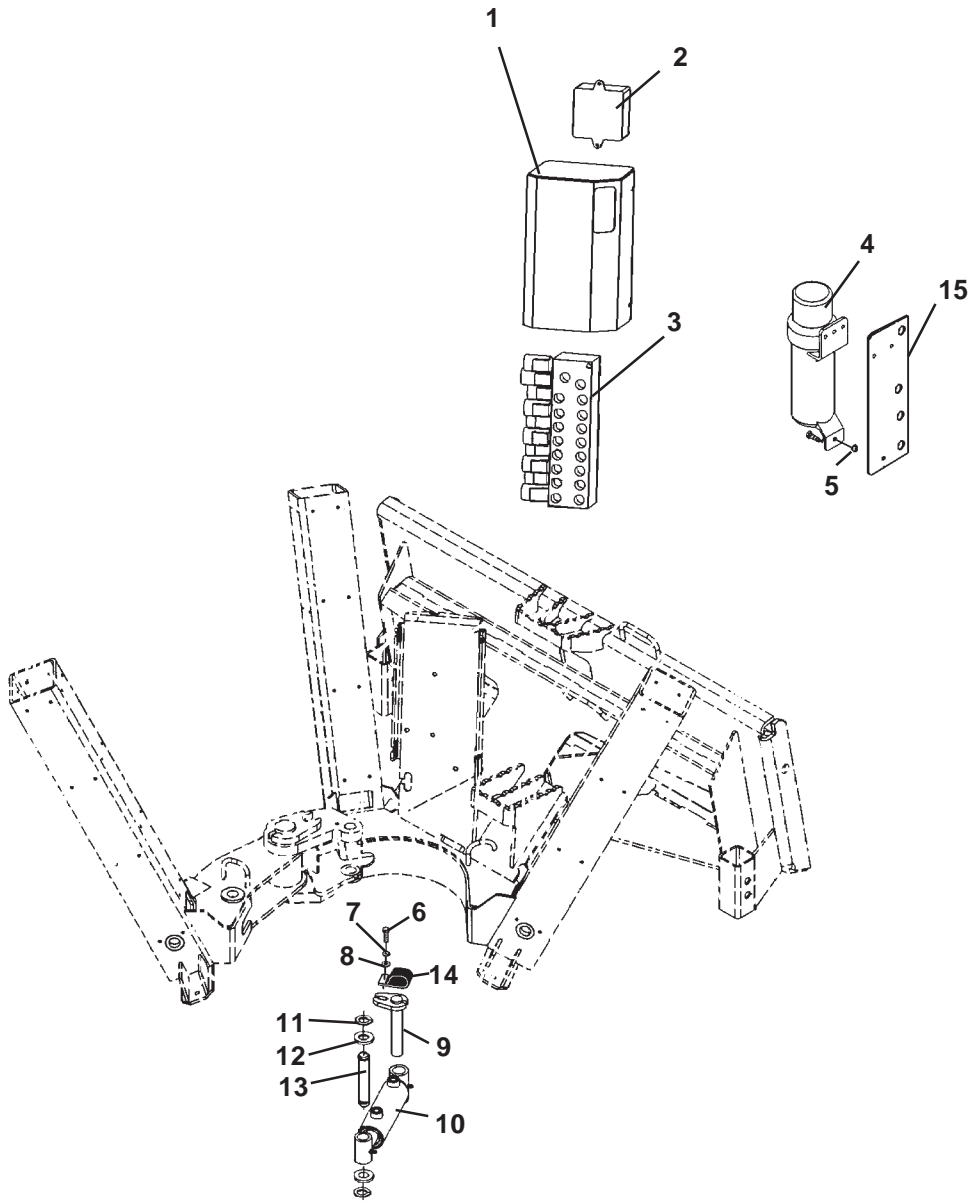



**2625 TREE SPADE**

ASSEMBLY #25670

<u>NO</u>	<u>REQ'D</u>	<u>PART NO.</u>	<u>DESCRIPTION</u>
1	1	25517	Valve Cover
	4	1930	.31" UNC x .75" Machine Screw
2	-	--	Junction Box (Included in Valve and Harness Assembly)
	2	1004	.25 UNC X 1.25" Hex Capscrew
	2	1512	.25" Flat Washer
	2	1629	.25" UNC Nylock Nut
3	1	25427	Valve Assembly with Wire Harness & Controls
	2	1035	.31" UNC X 4.50" Hex Capscrew
	2	1513	.31" Flat Washer
	2	1753	.31" UNC Nylock Nut
4	1	25453	Manual Storage Tube
5	3	1022	.31" UNC X 1.00" Hex Capscrew
	3	1513	.31" Flat Washer
	3	1753	.31" UNC Nylock Nut
6	1	1044	.38" UNC X 1.25" Hex Capscrew
7	1	1503	.38" Lock Washer
8	1	1800	.38" Hard Flat Washer
9	1	32392	Cylinder Pin 1.00" X 5.06"
10	1	25659	Cylinder Assembly - Gate
11	2	6612	Snap Ring
12	2	57462	Thrust Washer
13	1	57457	Cylinder Pin 1.00" X 4.75"
14	1	82859	Hose Clamp
15	1	25803	Storage Tube Mounting Plate

# 3625 TREE SPADE

ASSEMBLY #25370

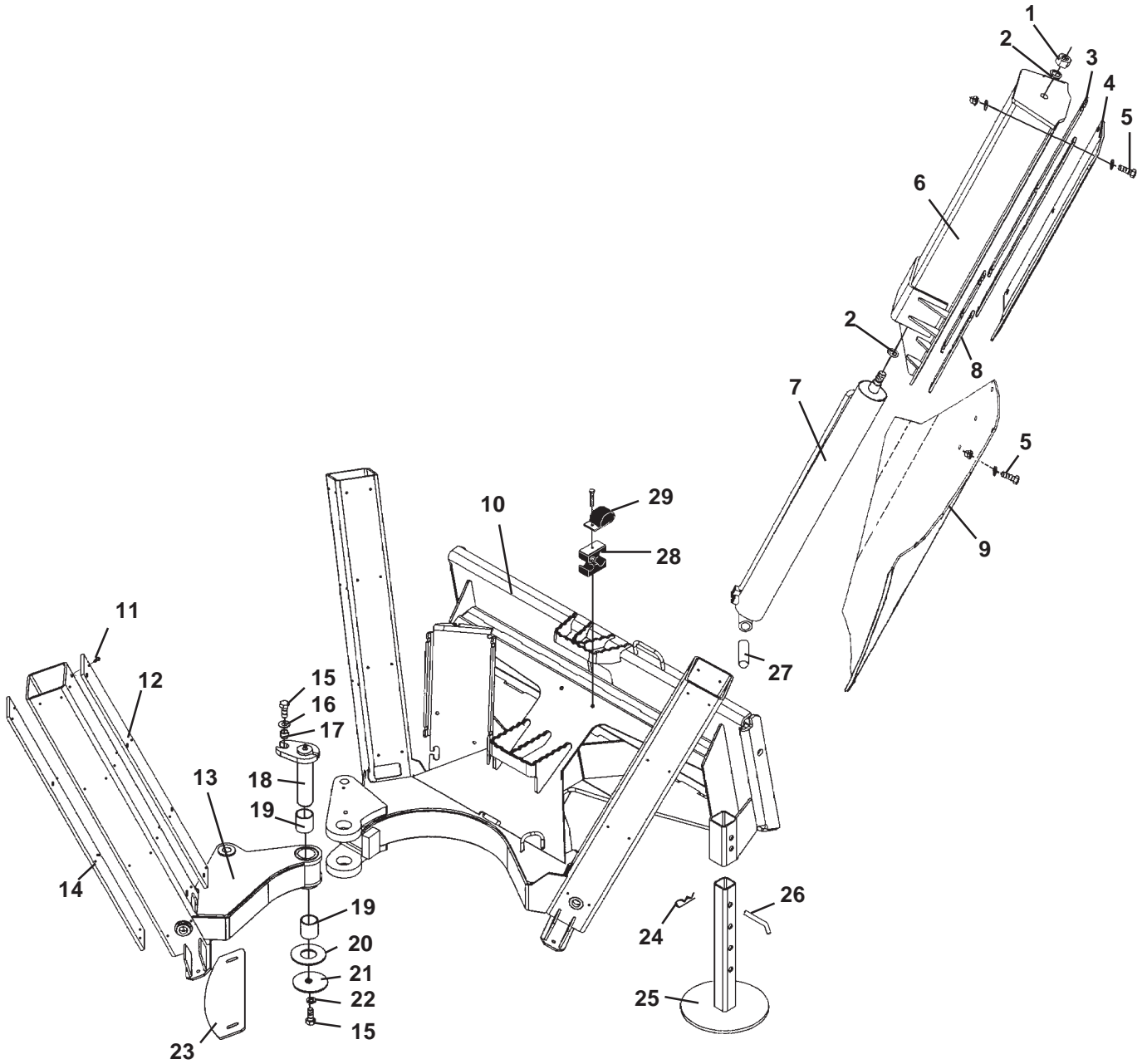

**3625 TREE SPADE**

ASSEMBLY #25370

<u>NO</u>	<u>REQ'D</u>	<u>PART NO.</u>	<u>DESCRIPTION</u>
1	3	1482	.88" UNF Deformed Lock Nut
2	6	1845	.88" Hard Flat Washer
3	12	25356	Shim
4	3	25355	Tower Cover
5	36	1841	.50" UNC Deformed Lock Nut
	48	1646	.50" Hard Flat Washer
	12	1090	.50 UNC X 1.50" Hex Capscrew
	24	1781	.50 UNC X 2.00" Hex Capscrew (Blades) GR 8
6	3	25353	Tower
7	3	25352	Cylinder Assembly - Blades
8	12	25357	Shim
9	3	25354	Blade
10	1	25348	Mainframe
11	96	10082	.31" UNC X .62" Flathead Capscrew
12	3	25359	Wear Plate 4" X 33"
13	1	25349	Arm
14	9	25360	Wear Plate 4" X 36"
15	2	1114	.62" UNC X 1.50" Hex Capscrew
16	1	1627	.62" Hard Flat Wsher
17	1	25075	Spacer
18	1	25358	Pivot Pin
	1	6616	Grease Fitting
19	2	6356	Replacement Bushing (Included with Arm Weldment)
20	As Req'd	6622	Thrust Washer
21	1	25132	Special Washer (.69" X 2.50" X .38")
22	1	1506	.62" Lock Washer
23	3	25382	Scraper Plate
	6	1044	.38" UNC X 1.25" Hex Capscrew
	6	1800	.38" Hard Flat Washer
	6	1837	.38" UNC Deformed Lock Nut
24	2	1860	Hair Pin
25	2	25144	Leg
26	2	89951	Hlitch Pin (Includes Hair Pin)
27	3	77553	Pin
28	1	17025	Hose Clamp
	1	1029	.31" UNC X 2.75" Hex Capscrew
	1	1753	.31" UNC Nylock Nut
29	1	82859	Hose Clamp

# 3625 TREE SPADE

ASSEMBLY #25370

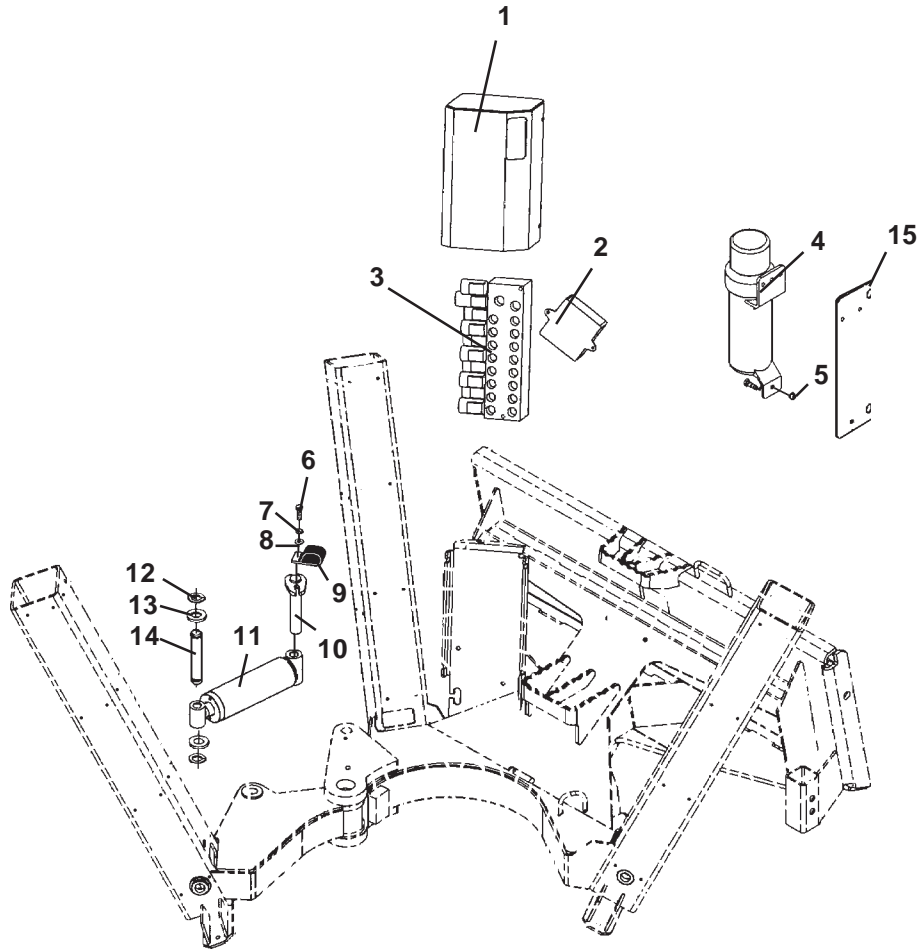

**3625 TREE SPADE**

ASSEMBLY #25370

<u>NO</u>	<u>REQ'D</u>	<u>PART NO.</u>	<u>DESCRIPTION</u>
1	1	25517	Valve Cover
	4	1930	.31" UNC x .75" Machine Screw
2	-	--	Junction Box (Included in Valve and Harness Assembly)
	2	1004	.25 UNC X 1.25" Hex Capscrew
	2	1512	.25" Flat Washer
	2	1629	.25" UNC Nylock Nut
3	1	25427	Valve Assembly with Wire Harness & Controls
	2	1035	.31" UNC X 4.50" Hex Capscrew
	2	1513	.31" Flat Washer
	2	1753	.31" UNC Nylock Nut
4	1	25453	Manual Storage Tube
5	3	1022	.31" UNC X 1.00" Hex Capscrew
	3	1513	.31" Flat Washer
	3	1753	.31" UNC Nylock Nut
6	1	1044	.38" UNC X 1.25" Hex Capscrew
7	1	1503	.38" Lock Washer
8	1	1800	.38" Hard Flat Washer
9	1	82859	Hose Clamp
10	1	32392	Cylinder Pin 1.00" X 5.06"
11	1	25351	Cylinder Assembly - Gate
12	2	6612	Snap Ring
13	2	57462	Thrust Washer
14	1	88484	Cylinder Pin 1.00" X 4.54"
15	1	25716	Storage Tube Mounting Plate

# 4425 TREE SPADE

ASSEMBLY #25570

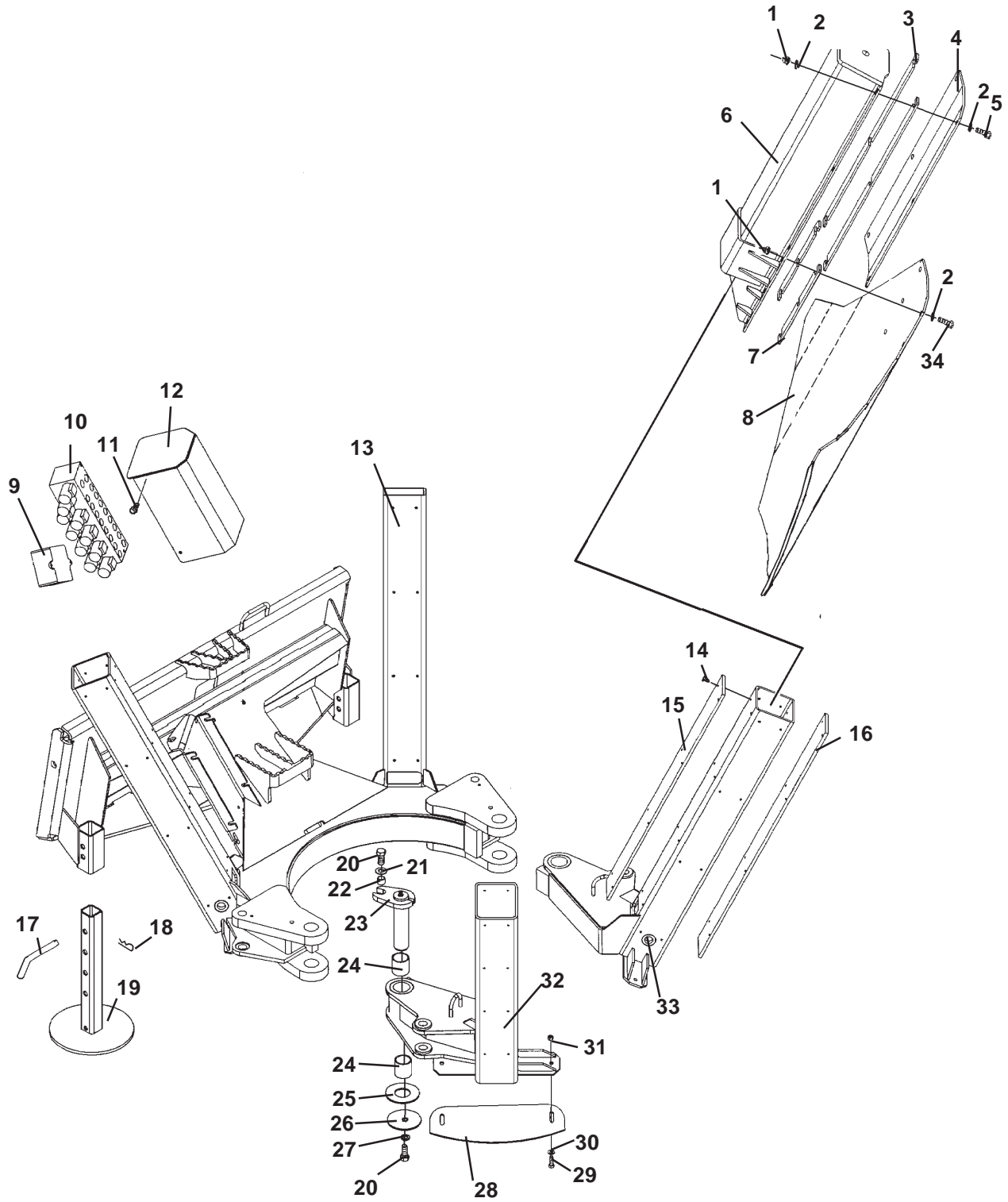

# 4425 TREE SPADE

ASSEMBLY #25570

<u>NO</u>	<u>REQ'D</u>	<u>PART NO.</u>	<u>DESCRIPTION</u>
1	48	1841	.50" UNC Deformed Lock Nut
2	64	1646	.50" Hard Flat Washer
3	16	25356	Shim
4	4	25355	Tower Cover
5	16	1090	.50 UNC X 1.50" Hex Capscrew
6	4	25353	Tower
7	16	25357	Shim
8	4	25578	Blade
9	-	--	Junction Box (Included in Valve and Harness Assembly)
	2	1004	.25 UNC X 1.25" Hex Capscrew
	2	1512	.25" Flat Washer
	2	1629	.25" UNC Nylock Nut
10	1	25427	Valve Assembly with Wire Harness & Controls
	2	1035	.31" UNC X 4.50" Hex Capscrew
	2	1513	.31" Flat Washer
	2	1753	.31" UNC Nylock Nut
11	4	1930	.31" UNC x .75" Machine Screw
12	1	25517	Valve Cover
13	1	25569	Mainframe
14	128	10082	.31" UNC X .62" Flathead Capscrew
15	4	25359	Wear Plate 4" X 33"
16	12	25360	Wear Plate 4" X 36"
17	2	89951	Hlitch Pin (Includes Hair Pin)
18	2	1860	Hair Pin
19	2	25144	Leg
20	4	1114	.62" UNC X 1.50" Hex Capscrew
21	2	1627	.62" Hard Flat Wsher
22	2	25075	Spacer
23	2	25574	Pivot Pin
	2	6616	Grease Fitting
24	2	6356	Replacement Bushing
			(Included with Left and Right Arm Weldments)
25	As Req'd	6622	Thrust Washer
26	2	25132	Special Washer (.69" X 2.50" X .38")
27	2	1506	.62" Lock Washer
28	4	25576	Scraper Plate
29	8	1044	.38" UNC X 1.25" Hex Capscrew
30	8	1800	.38" Hard Flat Washer
31	8	1837	.38" UNC Deformed Lock Nut
32	1	25567	Right Arm
33	1	25568	Left Arm
34	32	1781	.50 UNC X 2.00" Hex Capscrew (Blades) GR 8

# 4425 TREE SPADE

ASSEMBLY #25570

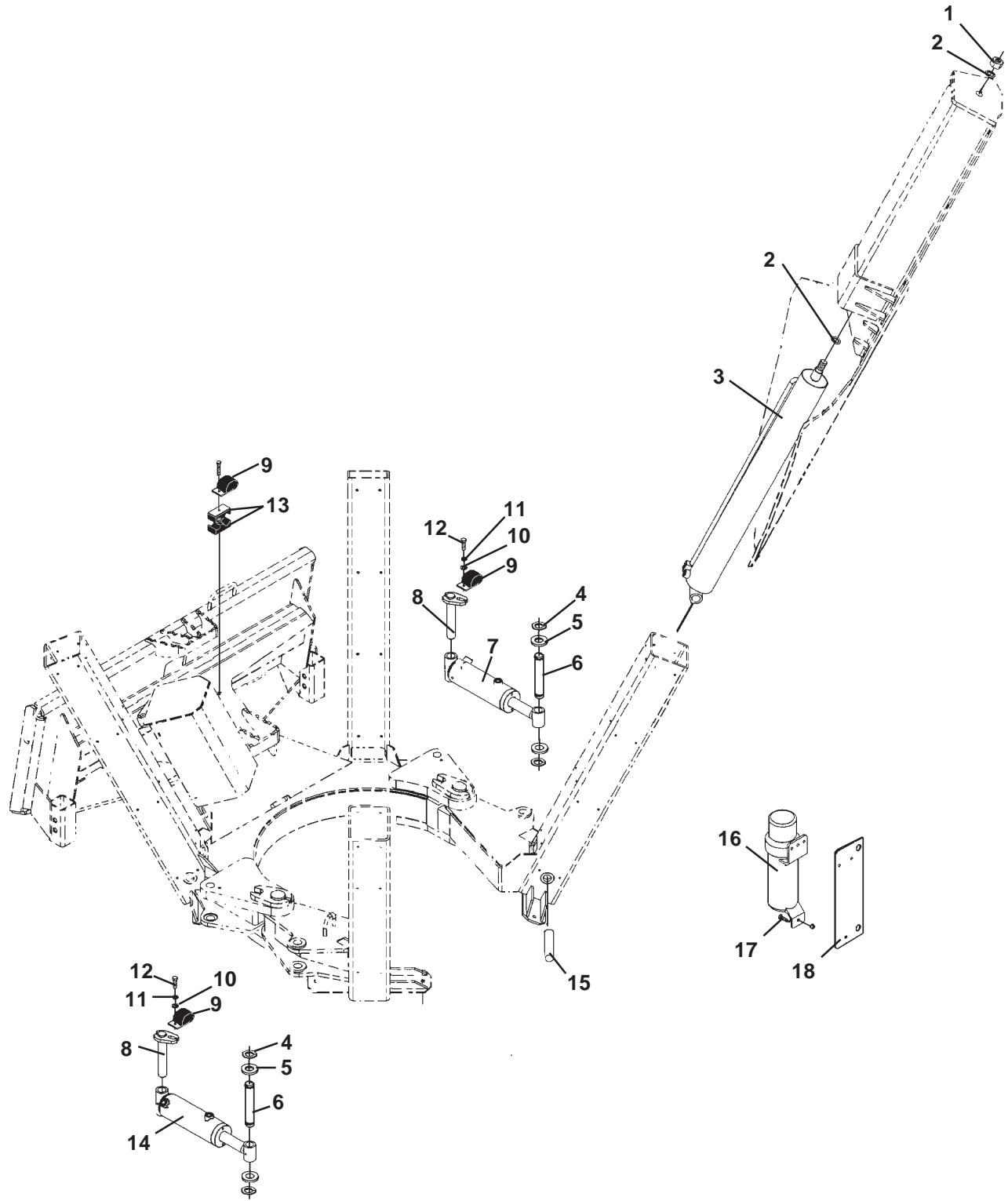



# 4425 TREE SPADE

ASSEMBLY #25570

<u>NO</u>	<u>REQ'D</u>	<u>PART NO.</u>	<u>DESCRIPTION</u>
1	4	1482	.88" UNF Deformed Lock Nut
2	8	1845	.88" Hard Flat Washer
6	4	25352	Cylinder Assembly - Blades
4	4	6612	Snap Ring
5	4	57462	Thrust Washer
6	2	88484	Cylinder Pin 1.00" X 4.54"
7	1	25571	Cylinder Assembly - Left Gate
8	2	18589	Cylinder Pin 1.00" X 5.81"
9	3	82859	Hose Clamp
10	2	1800	.38" Hard Flat Washer
11	2	1503	.38" Lock Washer
12	2	1044	.38" UNC X 1.25" Hex Capscrew
13	1	17025	Hose Clamp
	1	1029	.31" UNC X 2.75" Hex Capscrew
	1	1753	.31" UNC Nylock Nut
14	1	25351	Cylinder Assembly - Right Gate
15	4	77553	Pin
16	1	25453	Manual Storage Tube
17	3	1022	.31" UNC X 1.00" Hex Capscrew
	3	1513	.31" Flat Washer
	3	1753	.31" UNC Nylock Nut
18	1	25716	Storage Tube Mounting Plate

# MOUNTING KIT INSTALLATION

HOSE SET #25673 (Includes ALL Hoses for 2625 Tree Spade)  
HOSE SET #25643 (Includes ALL Hoses for 3625 Tree Spade)  
HOSE SET #25644 (Includes ALL Hoses for 4425 Tree Spade)  
2625, 3625, & 4425 POWER AND RETURN CIRCUIT

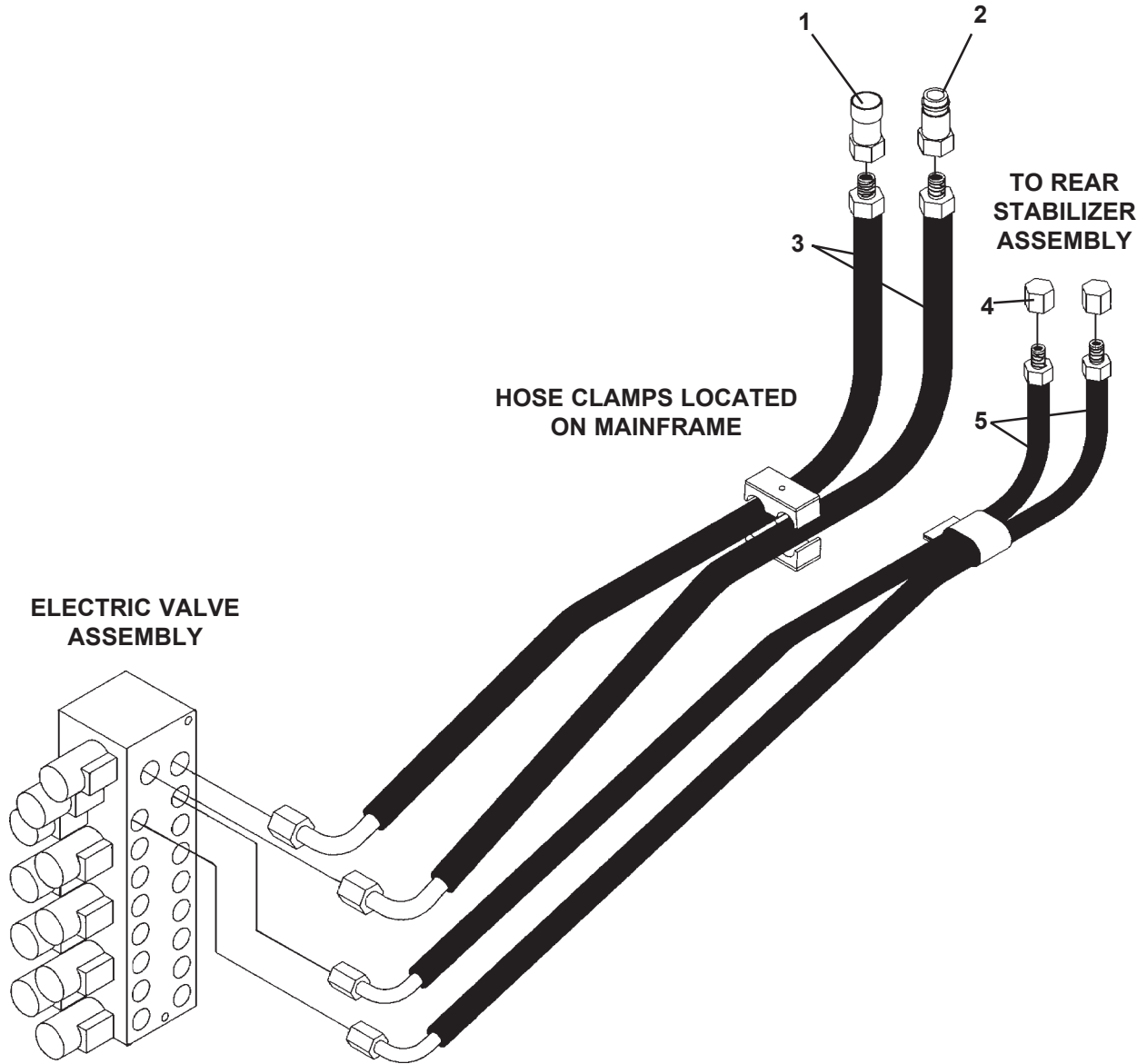

---

**MOUNTING KIT INSTALLATION**

---

HOSE SET #25673 (Includes ALL Hoses for 2625 Tree Spade)

HOSE SET #25643 (Includes ALL Hoses for 3625 Tree Spade)

HOSE SET #25644 (Includes ALL Hoses for 4425 Tree Spade)

2625, 3625, & 4425 POWER AND RETURN CIRCUIT

<u>NO</u>	<u>REQ'D</u>	<u>PART NO.</u>	<u>DESCRIPTION</u>
1	1	14175	Female Coupler
2	1	14176	Male Coupler
3	2	38244	Hose .50" X 80" 8MBo - .50 WEO 90°
4	2	3105	Cap
5	2	38254	Hose .38" X 22" 8MJ - .38 WEO 90°

# MOUNTING KIT INSTALLATION

HOSE SET #25673 (Includes ALL Hoses for 2625 Tree Spade)  
2625 BLADE CIRCUIT

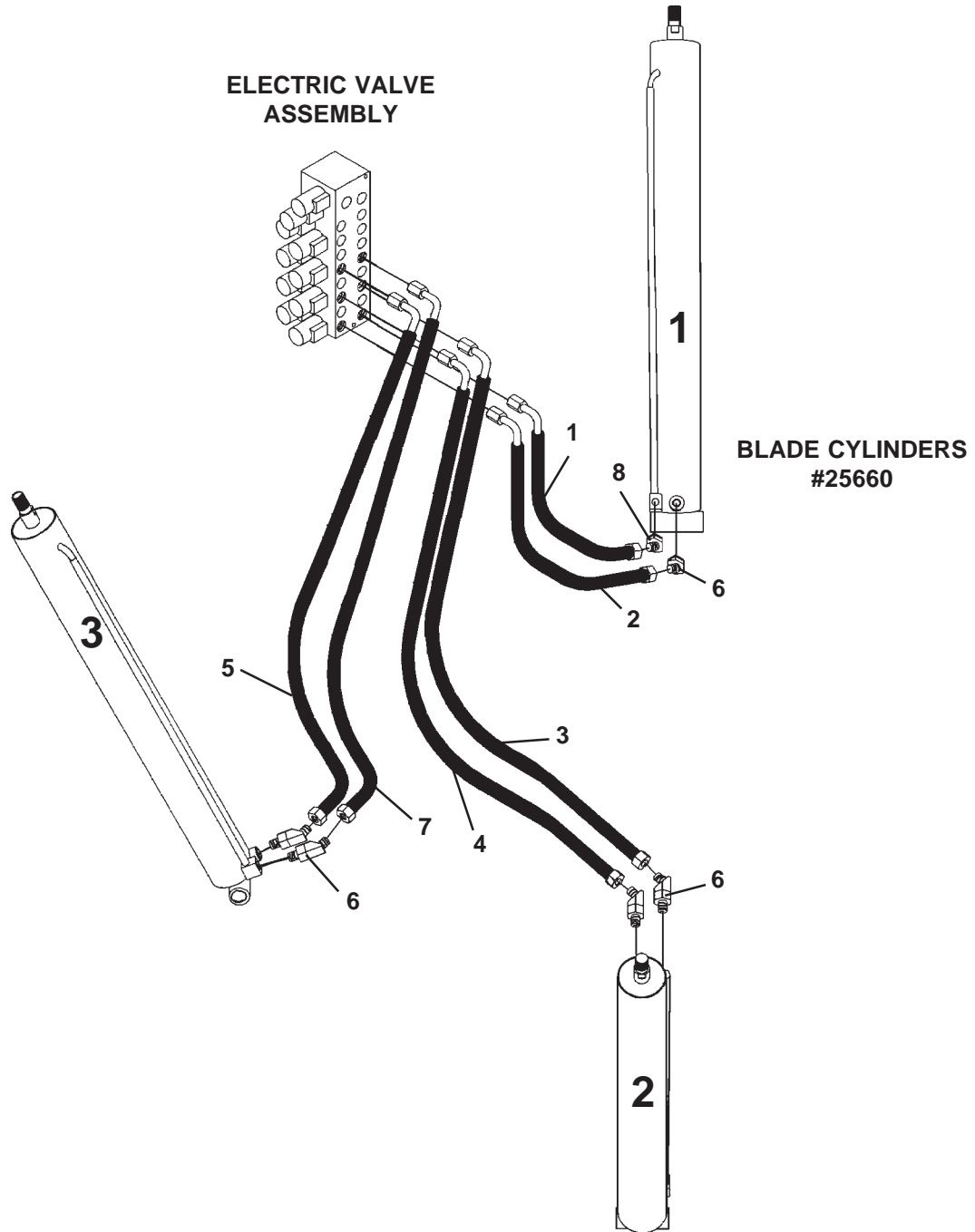

---

**MOUNTING KIT INSTALLATION**

---

HOSE SET #25673 (Includes ALL Hoses for 2625 Tree Spade)  
2625 BLADE CIRCUIT

<u>NO</u>	<u>REQ'D</u>	<u>PART NO.</u>	<u>DESCRIPTION</u>
1	1	38298	Hose .25" X 13" 6FJX - .38 WEO 90°
2	1	38267	Hose .25" X 18" 6FJX - .38 WEO 90°
3	1	38257	Hose .25" X 36" 6FJX - .38 WEO 90°
4	1	38270	Hose .25" X 34" 6FJX - .38 WEO 90°
5	1	38265	Hose .25" X 15" 6FJX - .38 WEO 90°
6	5	30313	45° Elbow 6MBo-6MJ
7	1	38266	Hose .25" X 17" 6FJX - .38 WEO 90°
8	1	3457	Straight Adapter 6MBo-6MJ

# MOUNTING KIT INSTALLATION

HOSE SET #25673 (Includes ALL Hoses for 2625 Tree Spade)  
2625 GATE CIRCUIT

## ELECTRICAL VALVE ASSEMBLY

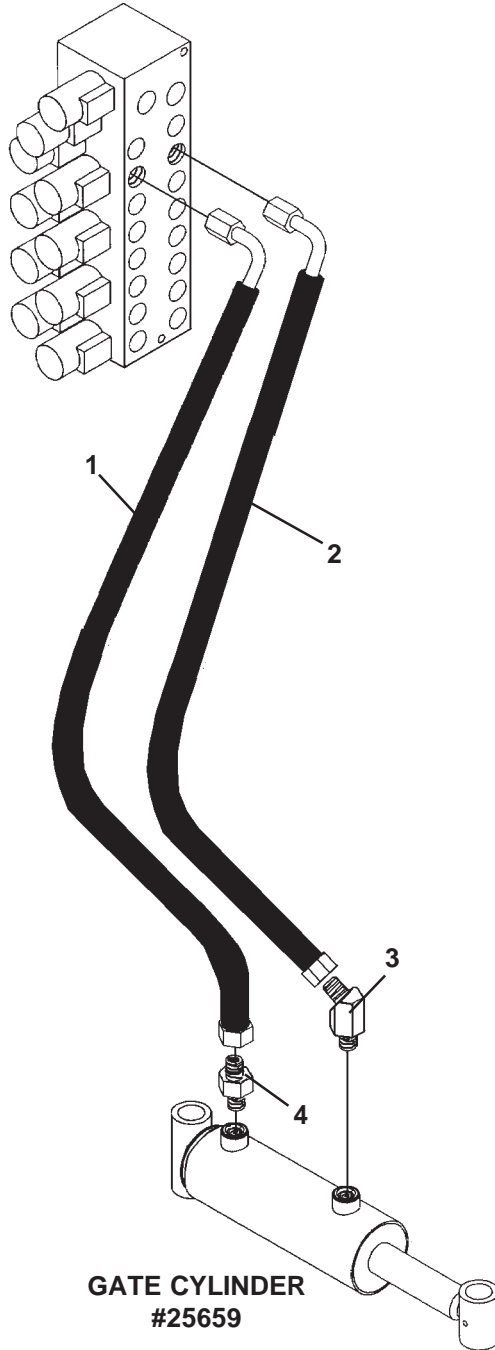

## GATE CYLINDER #25659

---

**MOUNTING KIT INSTALLATION**

---

HOSE SET #25673 (Includes ALL Hoses for 2625 Tree Spade)  
2625 GATE CIRCUIT

<u>NO</u>	<u>REQ'D</u>	<u>PART NO.</u>	<u>DESCRIPTION</u>
1	1	38267	Hose .25" X 18" 6FJX - .25 WEO 90°
2	1	38269	Hose .25" X 27" 6FJX - .25 WEO 90°
3	1	30313	45° Elbow 6MBo-6MJ
4	1	30185	Straight Adapter 6MBo-6MJ with .076 Orifice

# MOUNTING KIT INSTALLATION

HOSE SET #25643 (Includes ALL Hoses for 3625 Tree Spade)  
3625 BLADE CIRCUIT

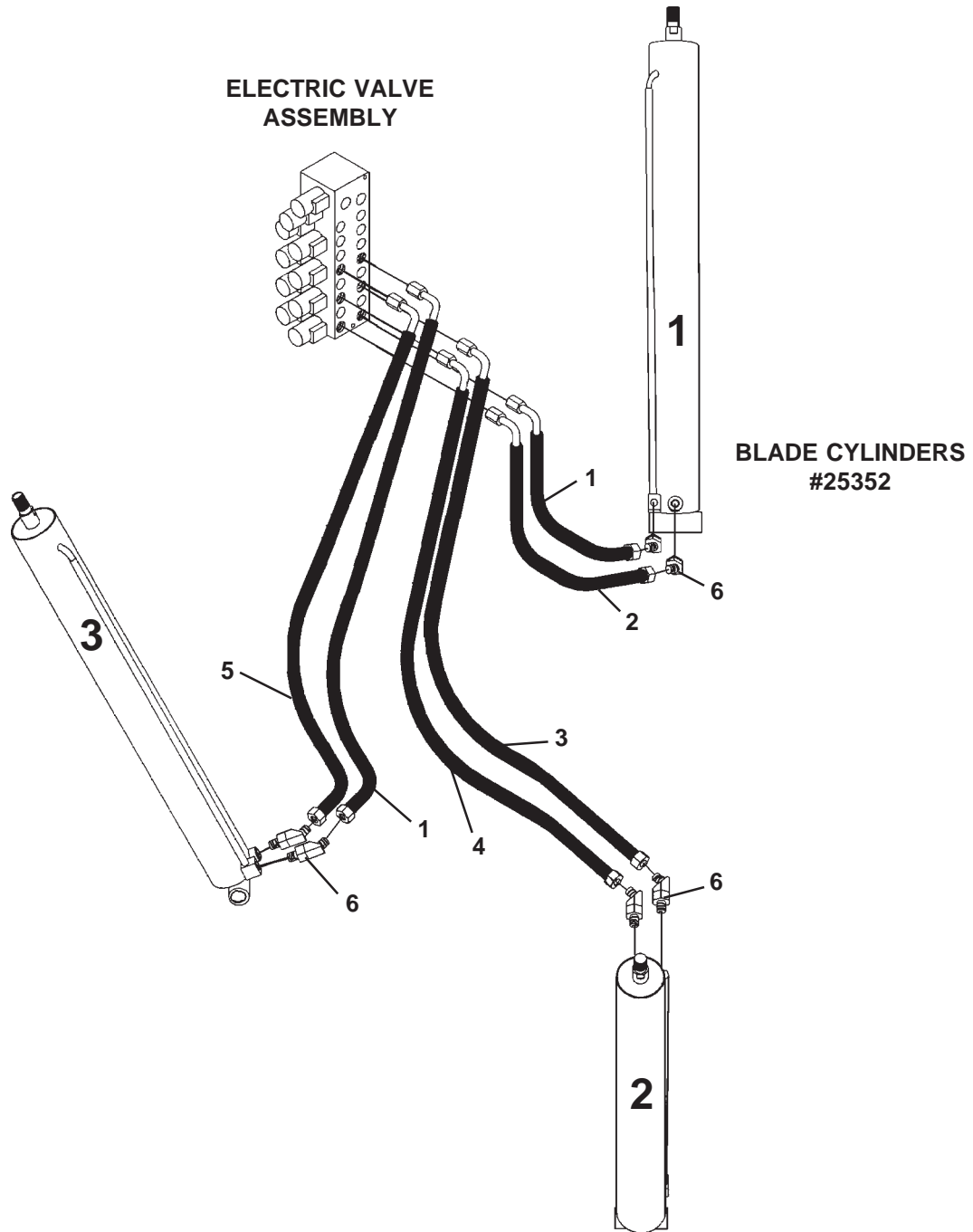



---

**MOUNTING KIT INSTALLATION**

---

HOSE SET #25643 (Includes ALL Hoses for 3625 Tree Spade)  
3625 BLADE CIRCUIT

<u>NO</u>	<u>REQ'D</u>	<u>PART NO.</u>	<u>DESCRIPTION</u>
1	2	38246	Hose .38" X 21" 6FJX - .38 WEO 90°
2	1	38275	Hose .38" X 23" 6FJX - .38 WEO 90°
3	1	38250	Hose .38" X 44" 6FJX - .38 WEO 90°
4	1	38249	Hose .38" X 43" 6FJX - .38 WEO 90°
5	1	38245	Hose .38" X 17" 6FJX - .38 WEO 90°
6	6	30313	45° Elbow 6MBo-6MJ

# MOUNTING KIT INSTALLATION

HOSE SET #25643 (Includes ALL Hoses for 3625 Tree Spade)  
3625 GATE CIRCUIT

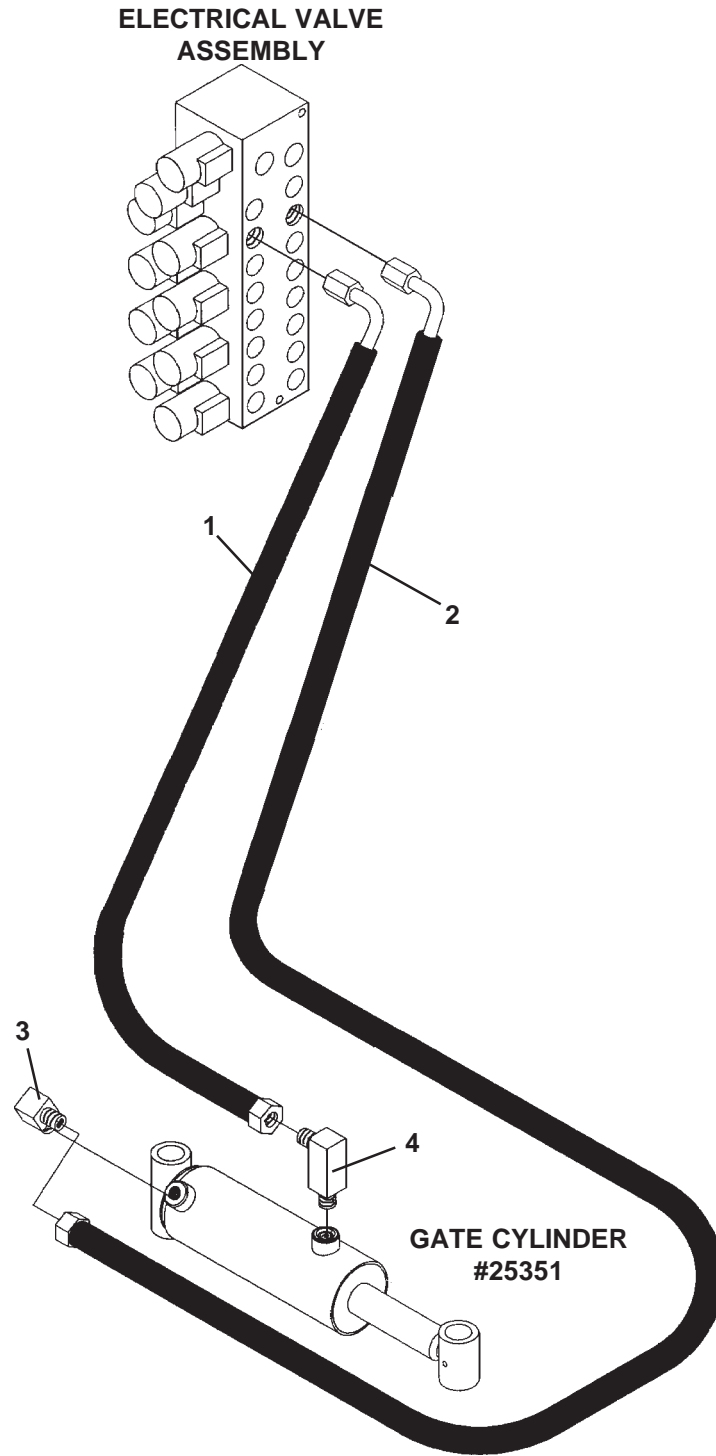

---

**MOUNTING KIT INSTALLATION**

---

HOSE SET #25643 (Includes ALL Hoses for 3625 Tree Spade)  
3625 GATE CIRCUIT

<u>NO</u>	<u>REQ'D</u>	<u>PART NO.</u>	<u>DESCRIPTION</u>
1	1	38269	Hose .25" X 27" 6FJX - .25 WEO 90°
2	1	38287	Hose .25" X 39" 6FJX - .25 WEO 90°
3	1	30259	90° Elbow 6MBo-6MJ with .060 Orifice
7	1	30169	90° Elbow 6MBo-6MJ-LONG

# MOUNTING KIT INSTALLATION

HOSE SET #25644 (Includes ALL Hoses for 4425 Tree Spade)  
4425 BLADE CIRCUIT

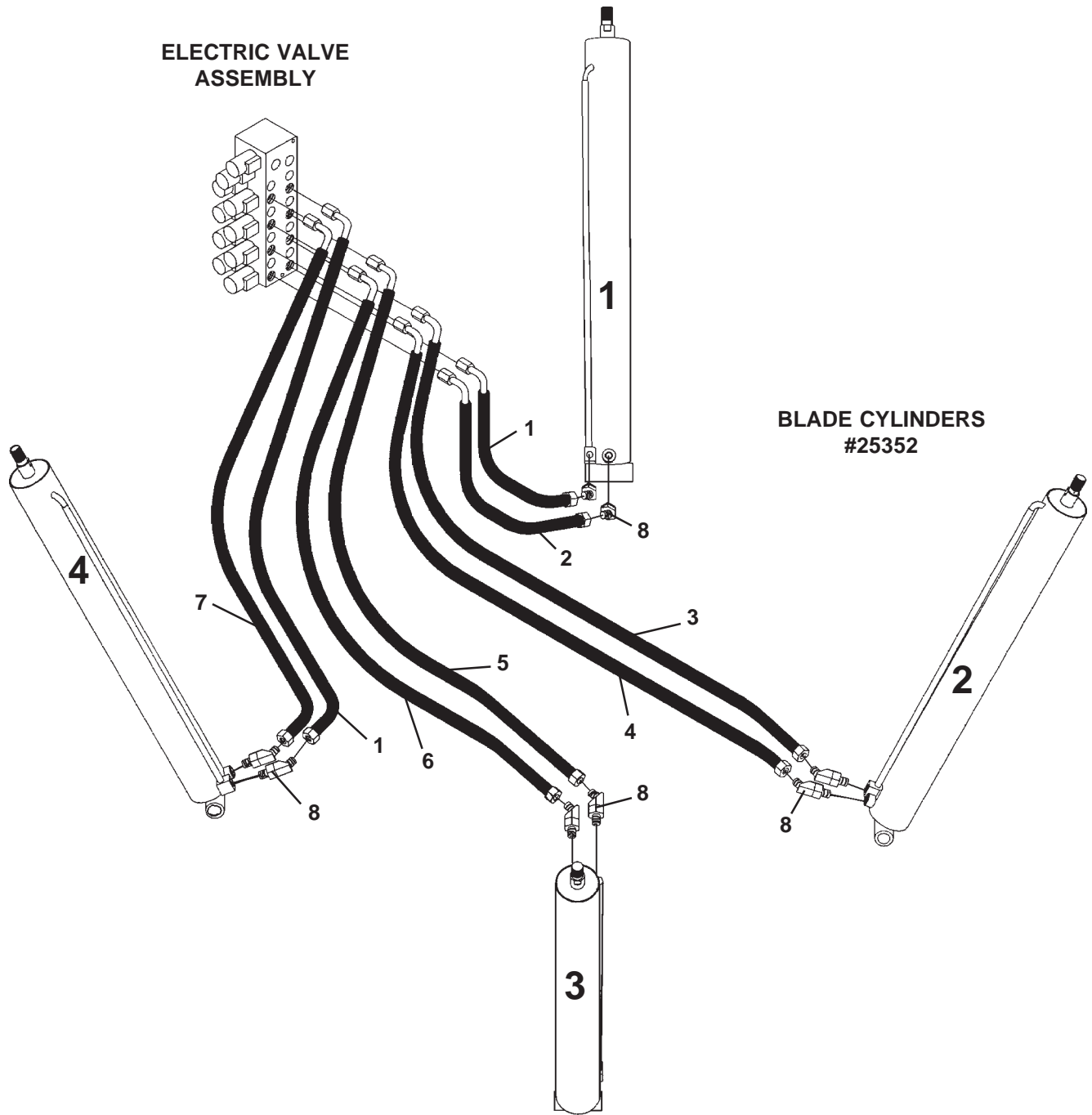

---

**MOUNTING KIT INSTALLATION**

---

HOSE SET #25644 (Includes ALL Hoses for 4425 Tree Spade)  
4425 BLADE CIRCUIT

<u>NO</u>	<u>REQ'D</u>	<u>PART NO.</u>	<u>DESCRIPTION</u>
1	2	38274	Hose .38" X 20" 6FJX - .38 WEO 90°
2	1	38275	Hose .38" X 23" 6FJX - .38 WEO 90°
3	1	38252	Hose .38" X 50" 6FJX - .38 WEO 90°
4	1	38253	Hose .38" X 52" 6FJX - .38 WEO 90°
5	1	38251	Hose .38" X 45" 6FJX - .38 WEO 90°
6	1	38248	Hose .38" X 41" 6FJX - .38 WEO 90°
7	1	38245	Hose .38" X 17" 6FJX - .38 WEO 90°
8	8	30313	45° Elbow 6MBo-6MJ

# MOUNTING KIT INSTALLATION

HOSE SET #25644 (Includes ALL Hoses for 4425 Tree Spade)  
4425 GATE CIRCUIT

## ELECTRICAL VALVE ASSEMBLY

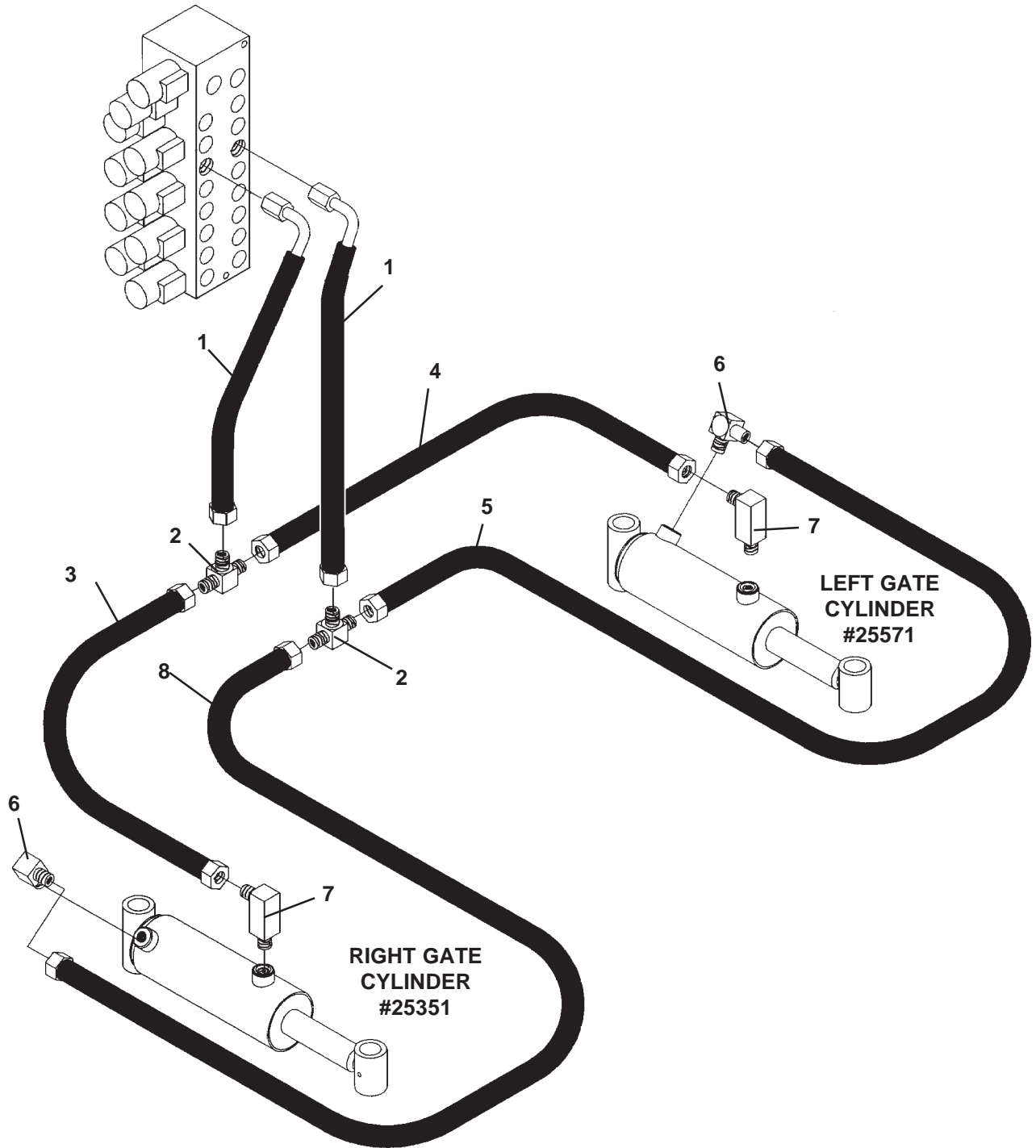

---

**MOUNTING KIT INSTALLATION**

---

HOSE SET #25644 (Includes ALL Hoses for 4425 Tree Spade)  
4425 GATE CIRCUIT

<u>NO</u>	<u>REQ'D</u>	<u>PART NO.</u>	<u>DESCRIPTION</u>
1	2	38255	Hose .25" X 12" 6FJX - .25 WEO 90°
2	2	3314	Tee 6MJ-6MJ-6MJ
3	1	38276	Hose .25" X 19" 6FJX - 6FJX
4	1	38156	Hose .25" X 38" 6FJX - 6FJX
5	1	38278	Hose .25" X 46" 6FJX - 6FJX
6	2	30259	90° Elbow 6MBo-6MJ with .060 Orifice
7	2	30140	90° Elbow 6MBo-6MJ-XL
4	1	38277	Hose .25" X 29" 6FJX - 6FJX

# MOUNTING KIT INSTALLATION

CYLINDER ASSEMBLY #25351

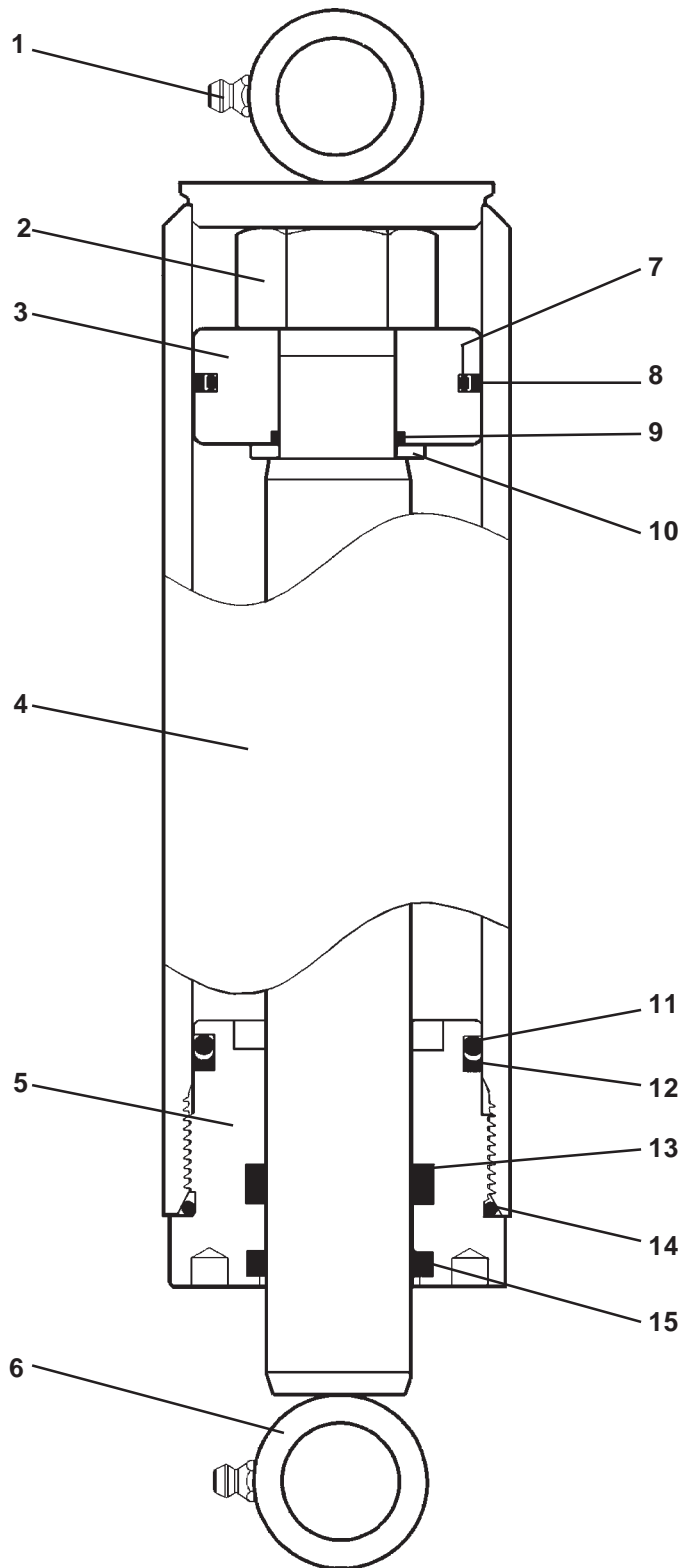



**MOUNTING KIT INSTALLATION**

CYLINDER ASSEMBLY #25351

<u>NO</u>	<u>REQ'D</u>	<u>PART NO.</u>	<u>DESCRIPTION</u>
1	1	6616	Grease Fitting
2	1	1483	Hex Nut
3	1	50252	Piston
4	1	25396	Cylinder Tube
5	1	77458	Cylinder Gland
6	1	25397	Cylinder Rod
7	1	4645*	O'Ring
8	1	4544*	Piston Ring
9	1	4641*	O'Ring
10	1	5421	Washer
11	1	4509*	O'Ring
12	1	4510*	Back-Up Washer
13	1	45219*	PolyPak Seal
14	1	45250*	O'Ring
15	1	45389*	Rod Wiper

**NOTE: Seal Kit #45617 includes all parts marked with an asterisk (\*). Parts are not sold separately.**

# MOUNTING KIT INSTALLATION

CYLINDER ASSEMBLY #25352

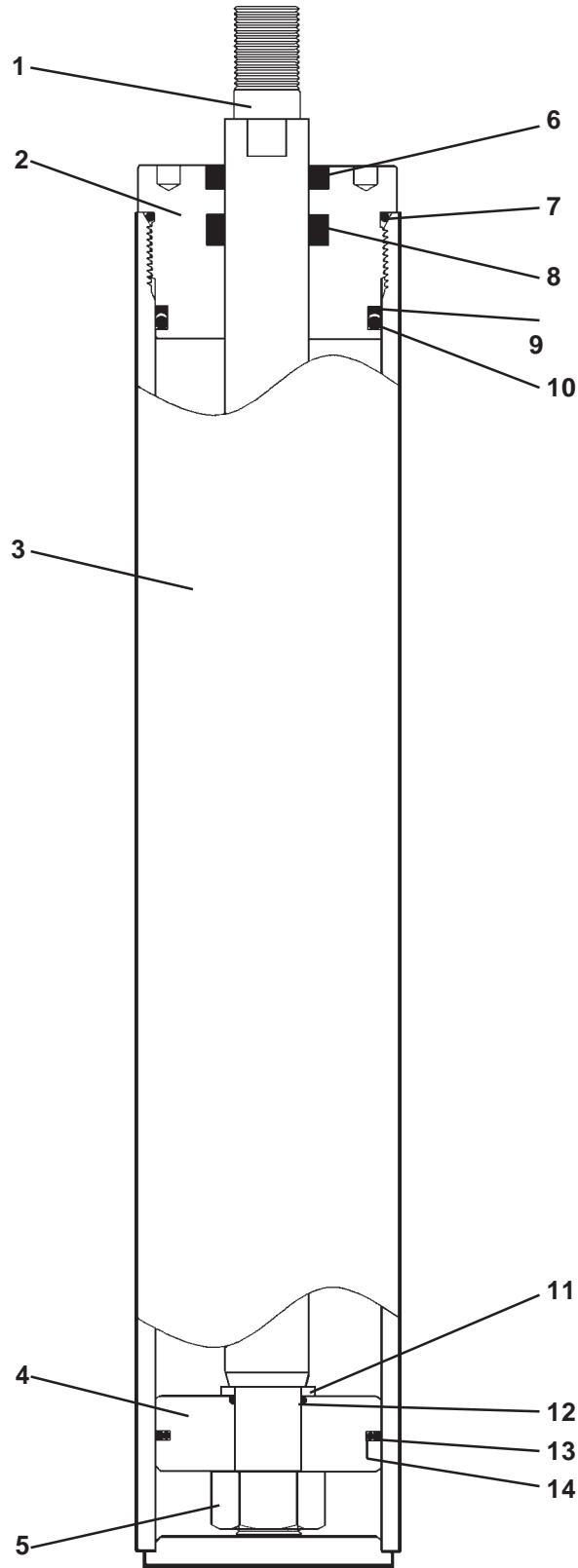

**MOUNTING KIT INSTALLATION**

CYLINDER ASSEMBLY #25352

<u>NO</u>	<u>REQ'D</u>	<u>PART NO.</u>	<u>DESCRIPTION</u>
1	1	25401	Cylinder Rod
2	1	25394	Cylinder Gland
3	1	25403	Cylinder Tube
4	1	25402	Piston
5	1	1482	Hex Nut
6	1	4981*	Rod Wiper
7	1	4908*	O'Ring
8	1	45262*	PolyPak Seal
9	1	4631*	Back-Up Washer
10	1	45555*	O'Ring
11	1	52644	Washer
12	1	4635*	O'Ring
13	1	4569*	Piston Ring
14	1	4570*	O-Ring

**NOTE: Seal Kit #45838 includes all parts marked with an asterisk (\*). Parts are not sold separately.**

# MOUNTING KIT INSTALLATION

CYLINDER ASSEMBLY #25571

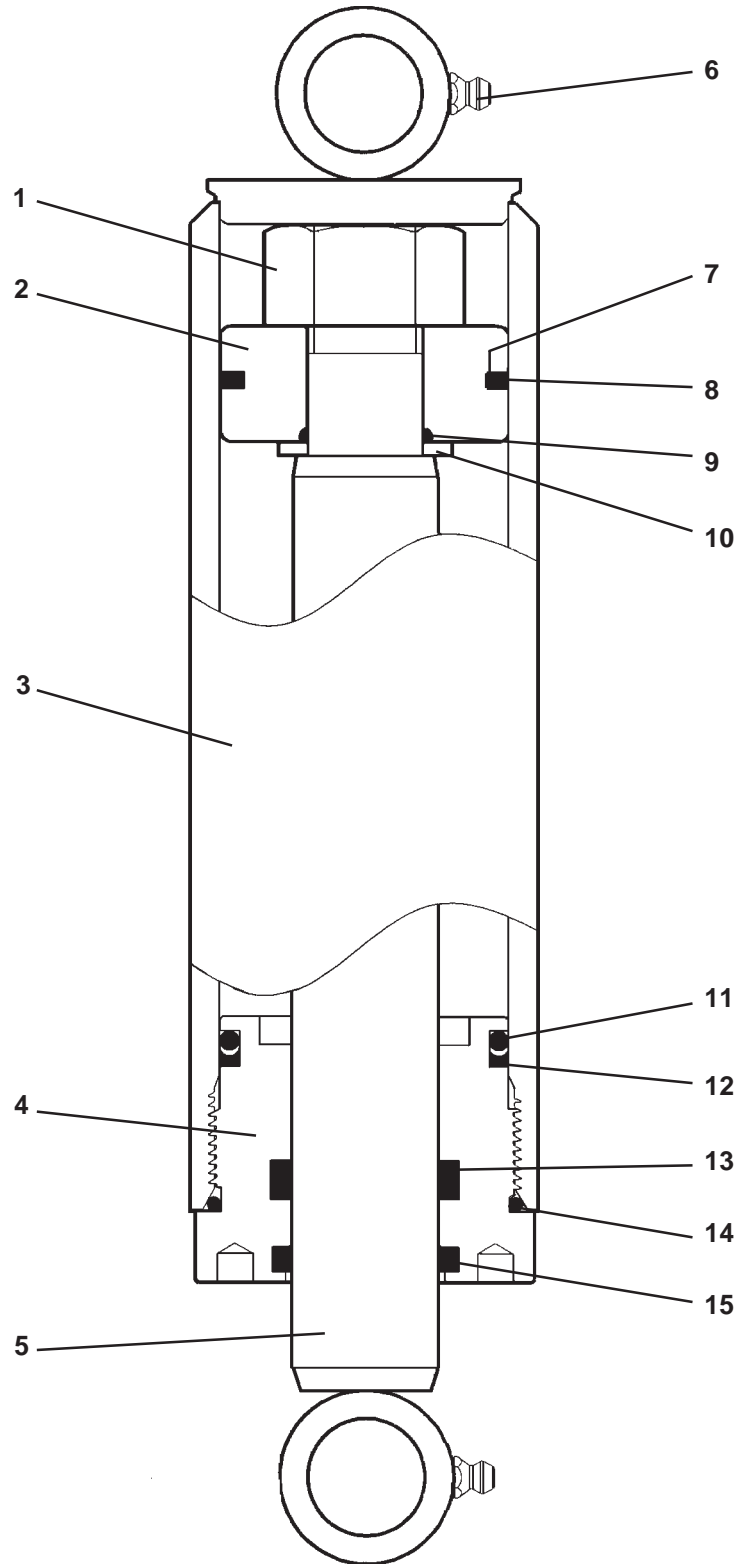

**MOUNTING KIT INSTALLATION**

CYLINDER ASSEMBLY #25571

<u>NO</u>	<u>REQ'D</u>	<u>PART NO.</u>	<u>DESCRIPTION</u>
1	1	1483	Hex Nut
2	1	50252	Piston
3	1	25572	Cylinder Tube
4	1	77458	Cylinder Gland
5	1	25397	Cylinder Rod
6	1	6616	Grease Fitting
7	1	4645*	O'Ring
8	1	4544*	Piston Ring
9	1	4641*	O'Ring
10	1	5421	Washer
11	1	4509*	O'Ring
12	1	4510*	Back-Up Washer
13	1	45219*	PolyPak Seal
14	1	45250*	O'Ring
15	1	45389*	Rod Wiper

**NOTE: Seal Kit #45617 includes all parts marked with an asterisk (\*). Parts are not sold separately.**

# MOUNTING KIT INSTALLATION

CYLINDER ASSEMBLY #25659

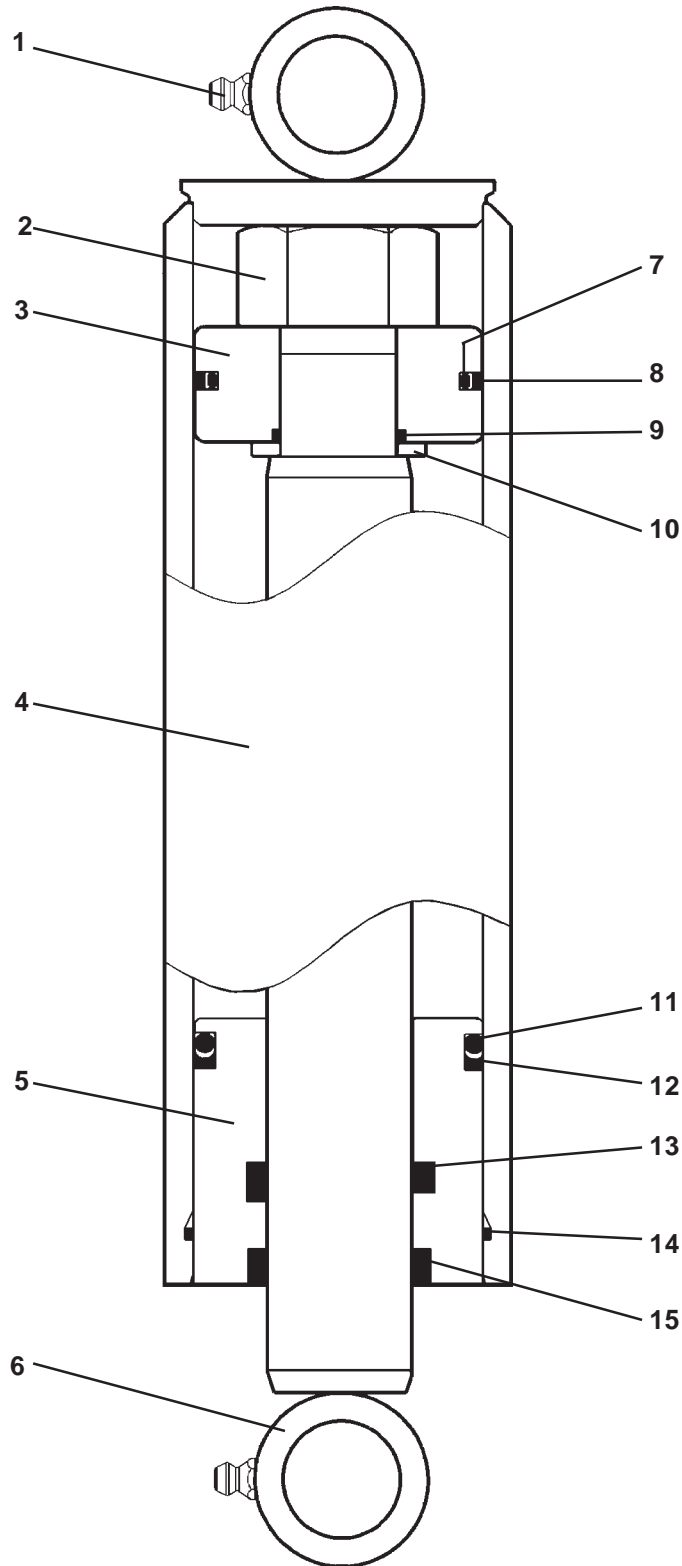

**MOUNTING KIT INSTALLATION**

CYLINDER ASSEMBLY #25659

<u>NO</u>	<u>REQ'D</u>	<u>PART NO.</u>	<u>DESCRIPTION</u>
1	1	6616	Grease Fitting
2	1	1482	Hex Nut
3	1	6992	Piston
4	1	25674	Cylinder Tube
5	1	64891	Cylinder Gland
6	1	25673	Cylinder Rod
7	1	4637*	O'Ring
8	1	4636*	Piston Ring
9	1	4635*	O'Ring
10	1	52644	Washer
11	1	4633*	O'Ring
12	1	4634*	Back-Up Washer
13	1	45262*	PolyPak Seal
14	1	7164*	Cylinder Gland Retaining Ring
15	1	4981*	Rod Wiper

**NOTE: Seal Kit #45581 includes all parts marked with an asterisk (\*). Parts are not sold separately.**

# MOUNTING KIT INSTALLATION

CYLINDER ASSEMBLY #25660

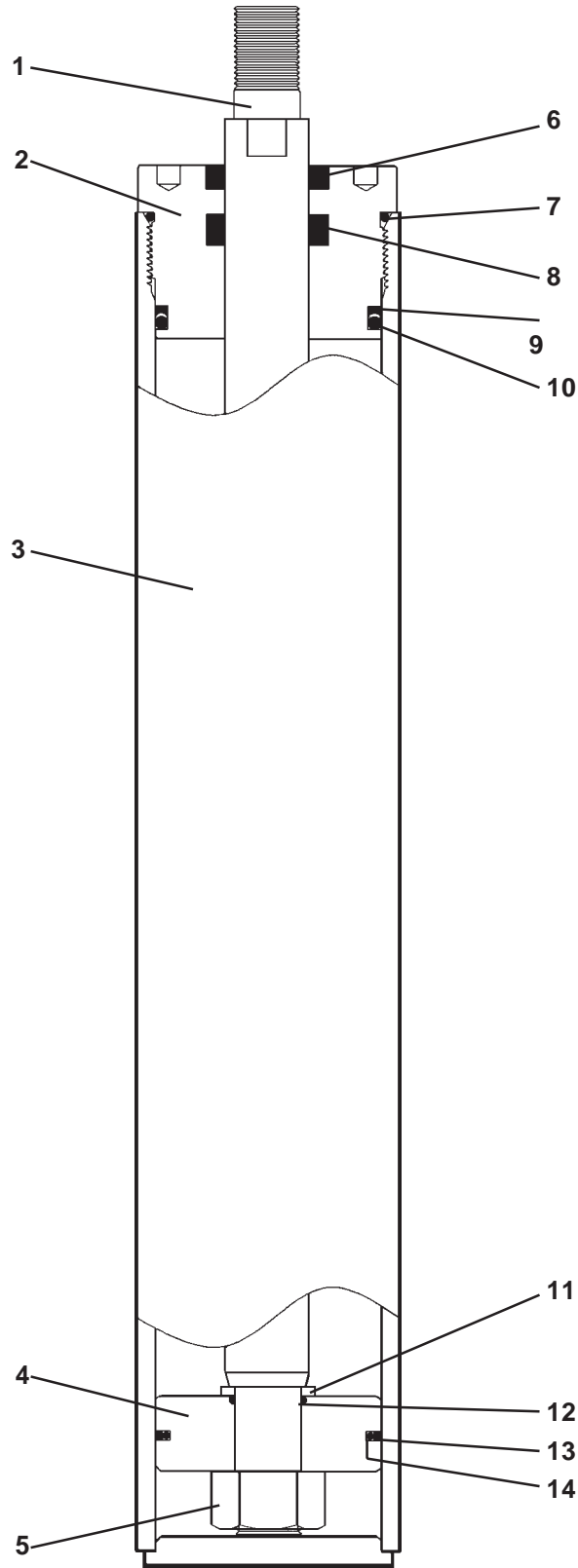



**MOUNTING KIT INSTALLATION**

CYLINDER ASSEMBLY #25660

<u>NO</u>	<u>REQ'D</u>	<u>PART NO.</u>	<u>DESCRIPTION</u>
1	1	25675	Cylinder Rod
2	1	77458	Cylinder Gland
3	1	25676	Cylinder Tube
4	1	50252	Piston
5	1	1483	Hex Nut
6	1	45389*	Rod Wiper
7	1	45250*	Cylinder Gland Retaining Ring
8	1	45219*	PolyPak Seal
9	1	4510*	Back-Up Washer
10	1	4509*	O'Ring
11	1	5421	Washer
12	1	4641*	O'Ring
13	1	4544*	Piston Ring
14	1	4645*	O-Ring

**NOTE: Seal Kit #45617 includes all parts marked with an asterisk (\*). Parts are not sold separately.**

# VALVE ASSEMBLY

VALVE ASSEMBLY #25456

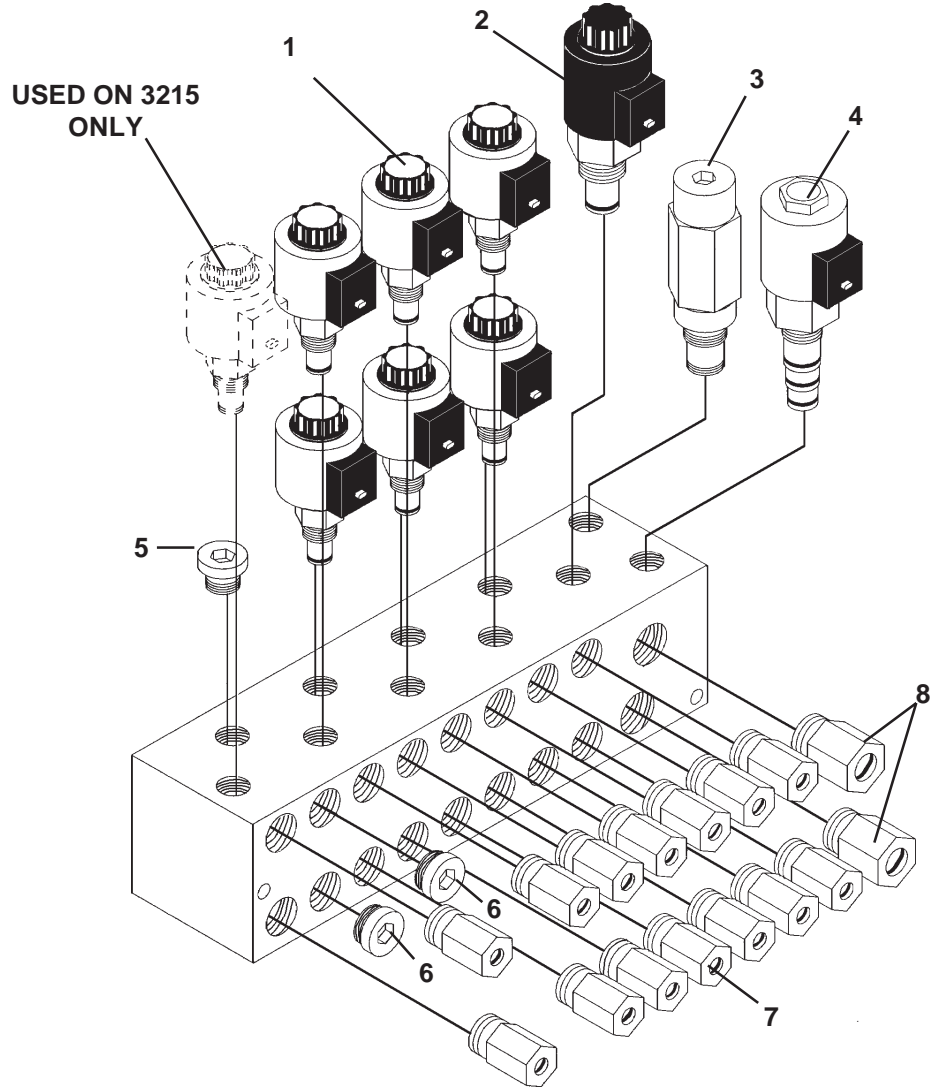

## HYDRAULIC SCHEMATIC

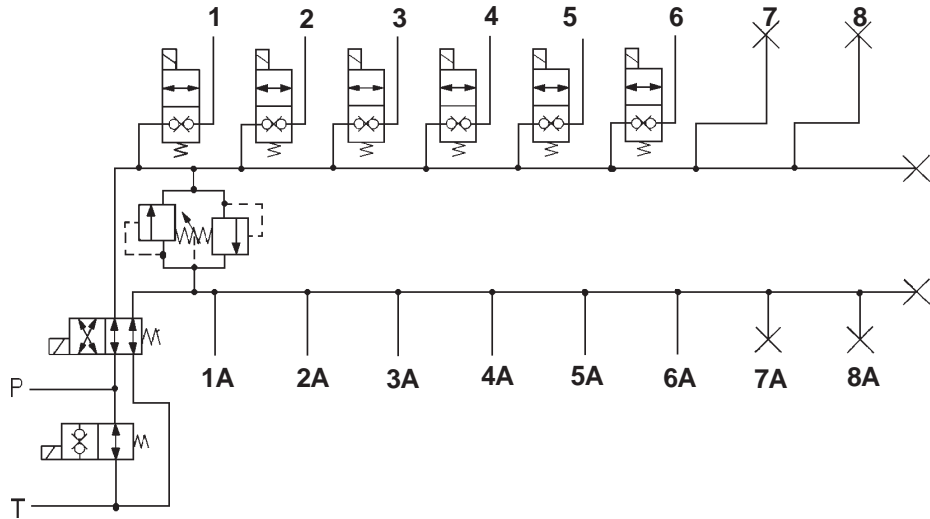

**VALVE ASSEMBLY**

VALVE ASSEMBLY #25456

<u>NO</u>	<u>REQ'D</u>	<u>PART NO.</u>	<u>DESCRIPTION</u>
1	6	45865	Circuit Control Spool Assembly - 2415
	6	45871	Coil Assembly
	7	45865	Circuit Control Spool Assembly - 3215
	7	45871	Coil Assembly
2	1	45867	Unloader Spool Assembly
	1	45872	Coil Assembly
3	1	45868	Relief Valve
4	1	45866	Reverse Spool Assembly
	1	45873	Coil Assembly
5	2	3341	Plug - 2415
	1	3341	Plug - 3215
6	4	3311	Plug - 2415
	2	3311	Plug - 3215
7	12	30348	Adapter - 2415
	14	30348	Adapter - 3215
8	2	30349	Adapter

<b>FUNCTION</b>	<b>WIRE COLOR</b>
<b>FLOW REVERSER</b>	<b>BLACK / WHITE</b>
<b>UNLOADER</b>	<b>GREEN</b>
<b>REAR STABILIZER</b>	<b>ORANGE</b>
<b>BLADE #1</b>	<b>BLUE</b>
<b>BLADE #2</b>	<b>BLUE / BLACK</b>
<b>BLADE #3</b>	<b>ORANGE / BLACK</b>
<b>BLADE #4</b> (if equipped)	<b>WHITE / BLACK</b>
<b>BLADE #5</b> (if equipped)	<b>WHITE</b>
<b>GATE</b>	<b>RED / BLACK</b>
<b>UNDERCUTTER</b> (if equipped)	<b>GREEN / BLACK</b>

# MOUNTING KIT INSTALLATION

ELECTRICAL ASSEMBLY #25427

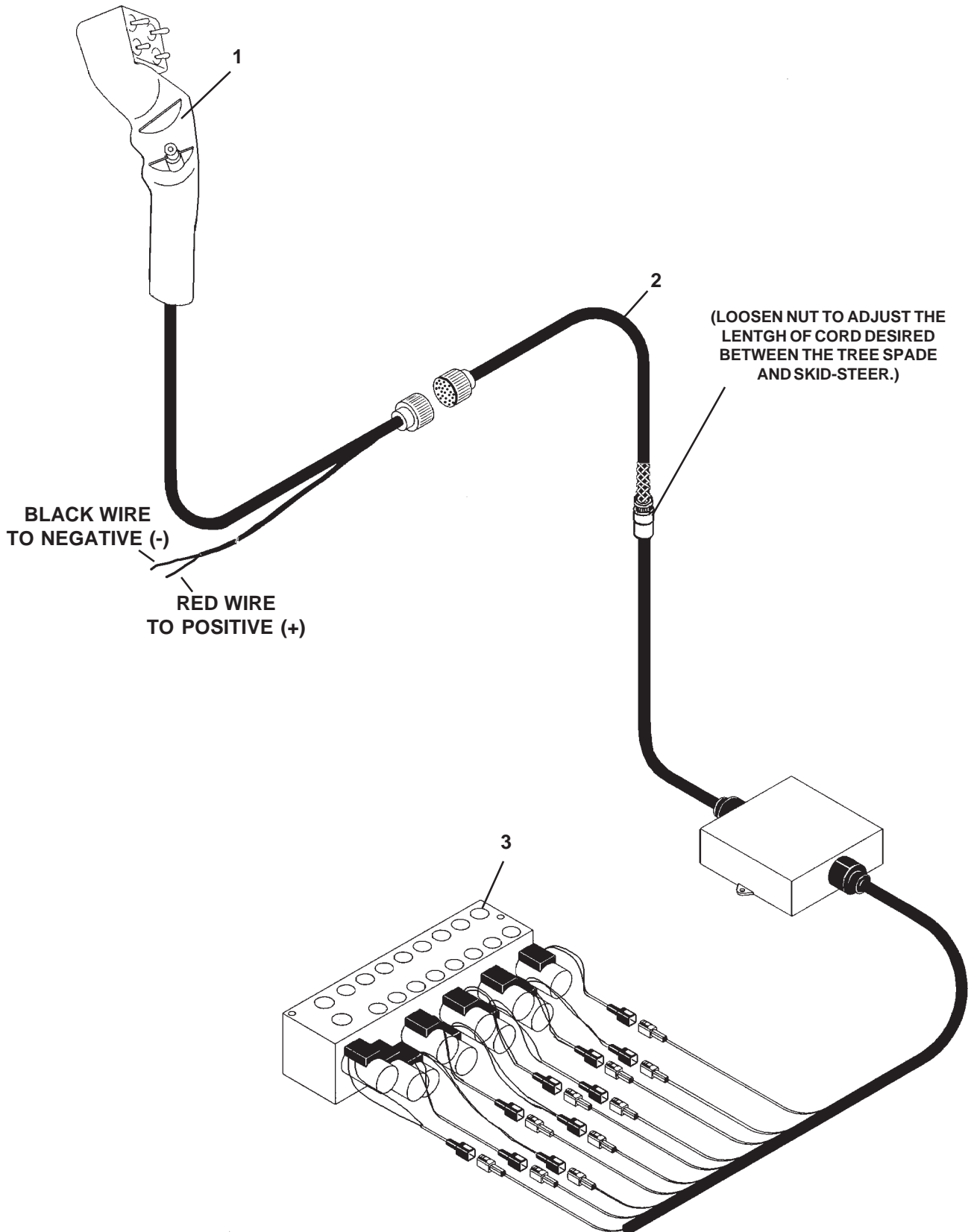

---

**MOUNTING KIT INSTALLATION**

---

ELECTRICAL ASSEMBLY #25427

<u>NO</u>	<u>REQ'D</u>	<u>PART NO.</u>	<u>DESCRIPTION</u>
1	1	25425	Joystick Assembly Includes Power Cord, Connector and Joystick
2	1	25455	Wire Harness Assembly Includes Power Cord, Connector and Junction Box
3	1	25456	Valve Assembly Includes Six Circuit Valve with #6 O'ring Ports, 26 GPM BiDirectional Unloader, 2200 PSI BiDirectional Relief Valve and Deutsch Connectors on Coils

# SOLENOID VALVES

## REPLACEMENT PARTS

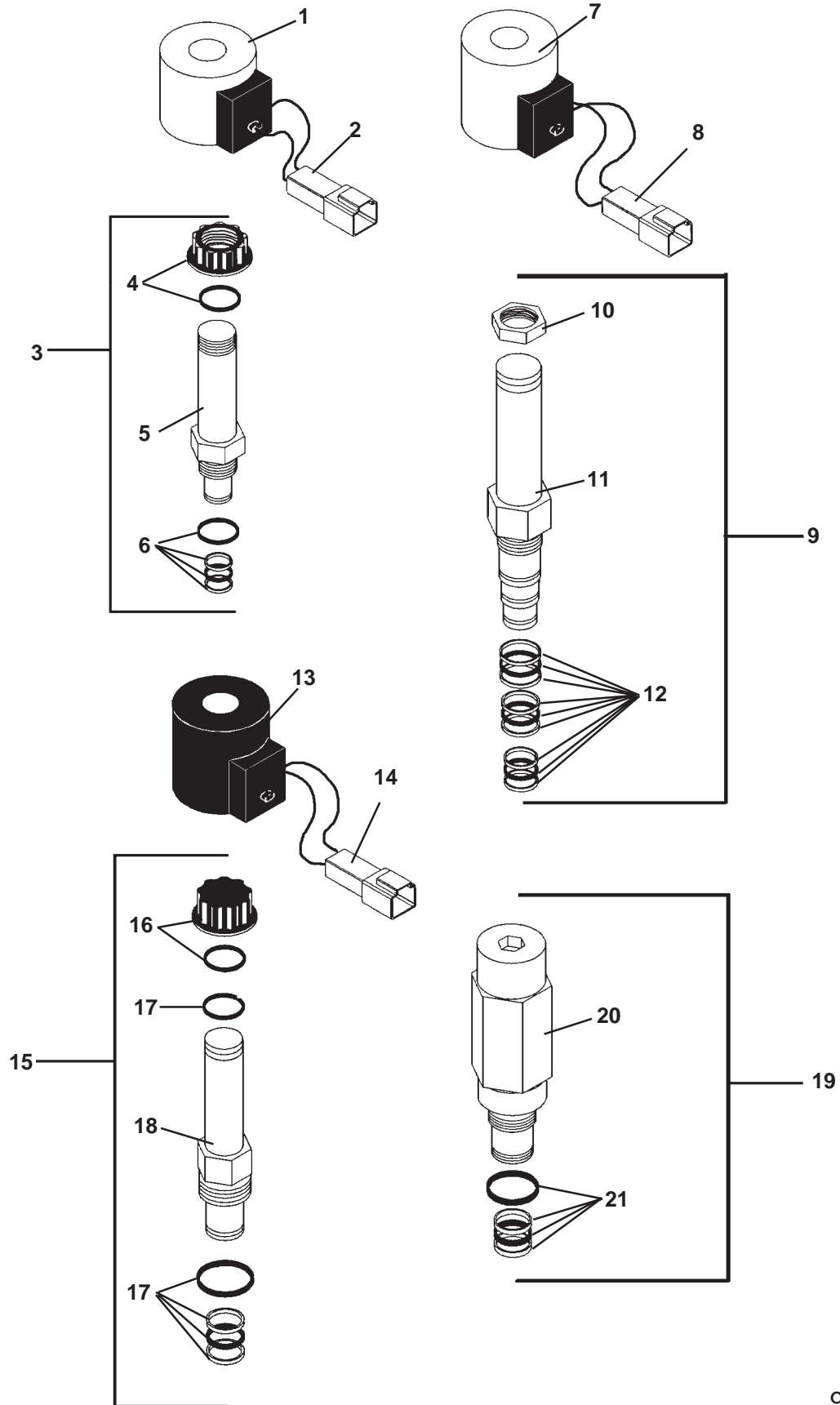

**SOLENOID VALVES**

## REPLACEMENT PARTS

<u>NO</u>	<u>REQ'D</u>	<u>PART NO.</u>	<u>DESCRIPTION</u>
1	1	45871	Coil (Includes #2)
2	1	25550	Wire Terminal Connector
3	Varies	45865	Circuit Control Spool Assembly (Includes items #4, #5 & #6)
4	1	45869	Nut Assembly (Includes O'Ring)
5	-	-----	Spool (Not Sold Separately)
6	1	45874	Replacement Seal Kit
7	1	45873	Coil (Includes #8)
8	1	25550	Wire Terminal Connector
9	1	45866	Reverse Valve Spool Assembly (Includes items #10, #11 & #12)
10	1	45830	Nut
11	-	-----	Spool (Not Sold Separately)
12	1	45875	Replacement Seal Kit
13	1	45872	Coil (Includes #14)
14	1	25550	Wire Terminal Connector
15	1	45867	Unloader Spool Assembly (Includes items #16, #17 & #18)
16	1	45870	Nut Assembly (Includes O'Ring)
17	1	45876	Replacement Seal Kit
18	-	-----	Spool (Not Sold Separately)
19	1	45868	Relief Valve (Includes items #20 & #21)
20	-	----	Relief Valve (Not Sold Separately)
21	1	45877	Replacement Seal Kit

# WIRING SCHEMATIC

REPLACEMENT PARTS FOR JOYSTICK ASSEMBLY #25425

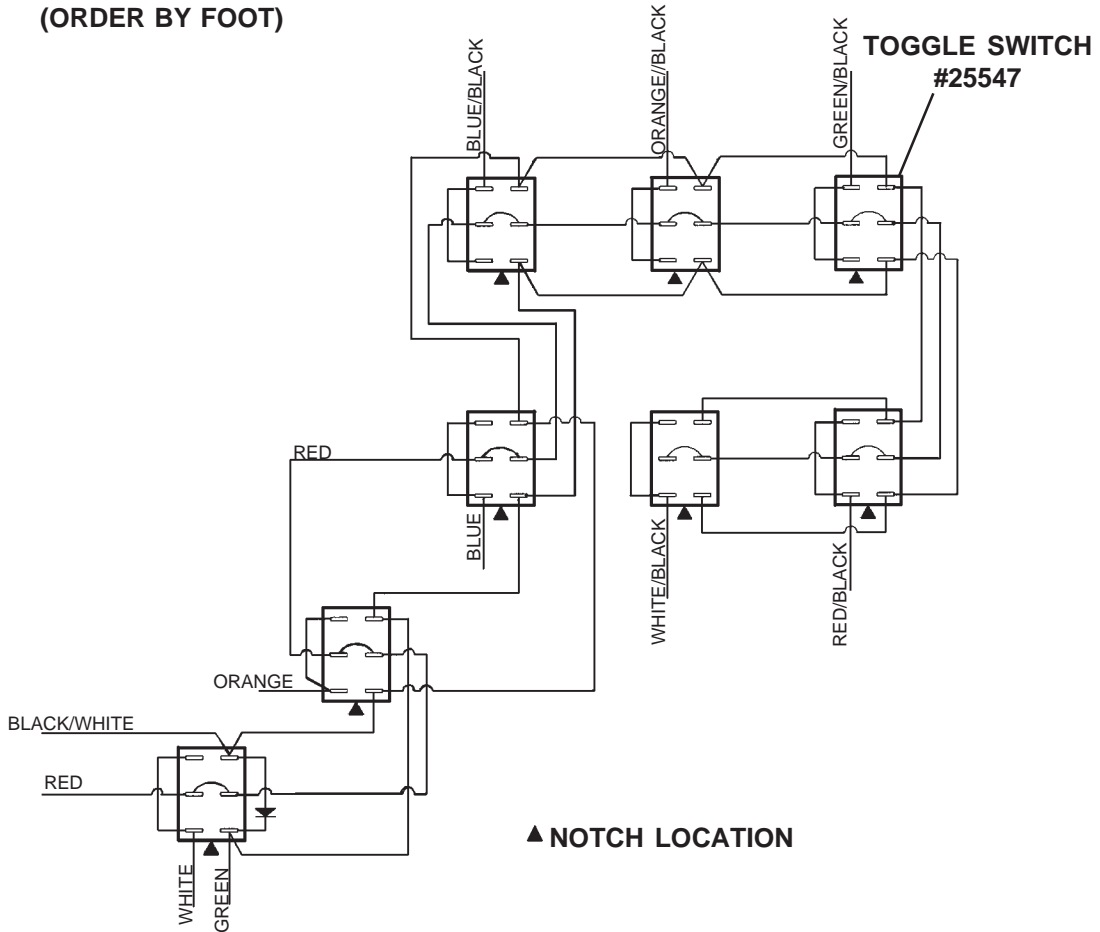
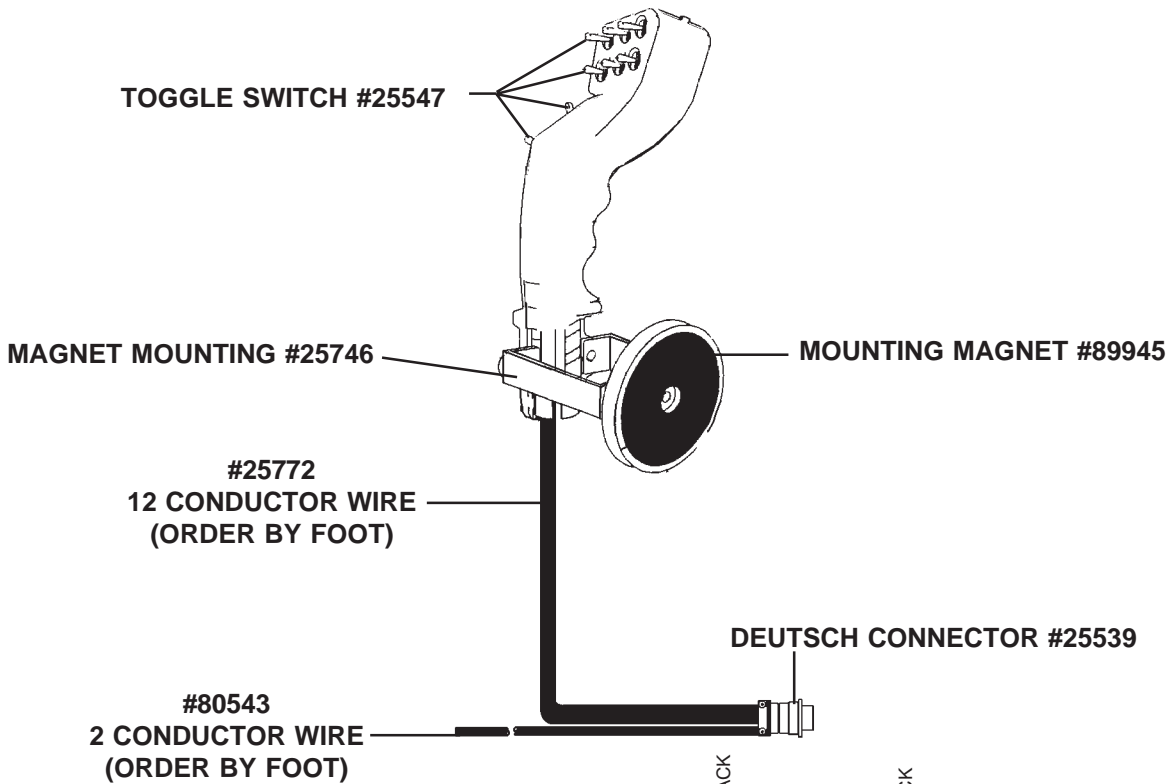



# WIRING SCHEMATIC

REPLACEMENT PARTS FOR WIRE HARNESS ASSEMBLY #25455

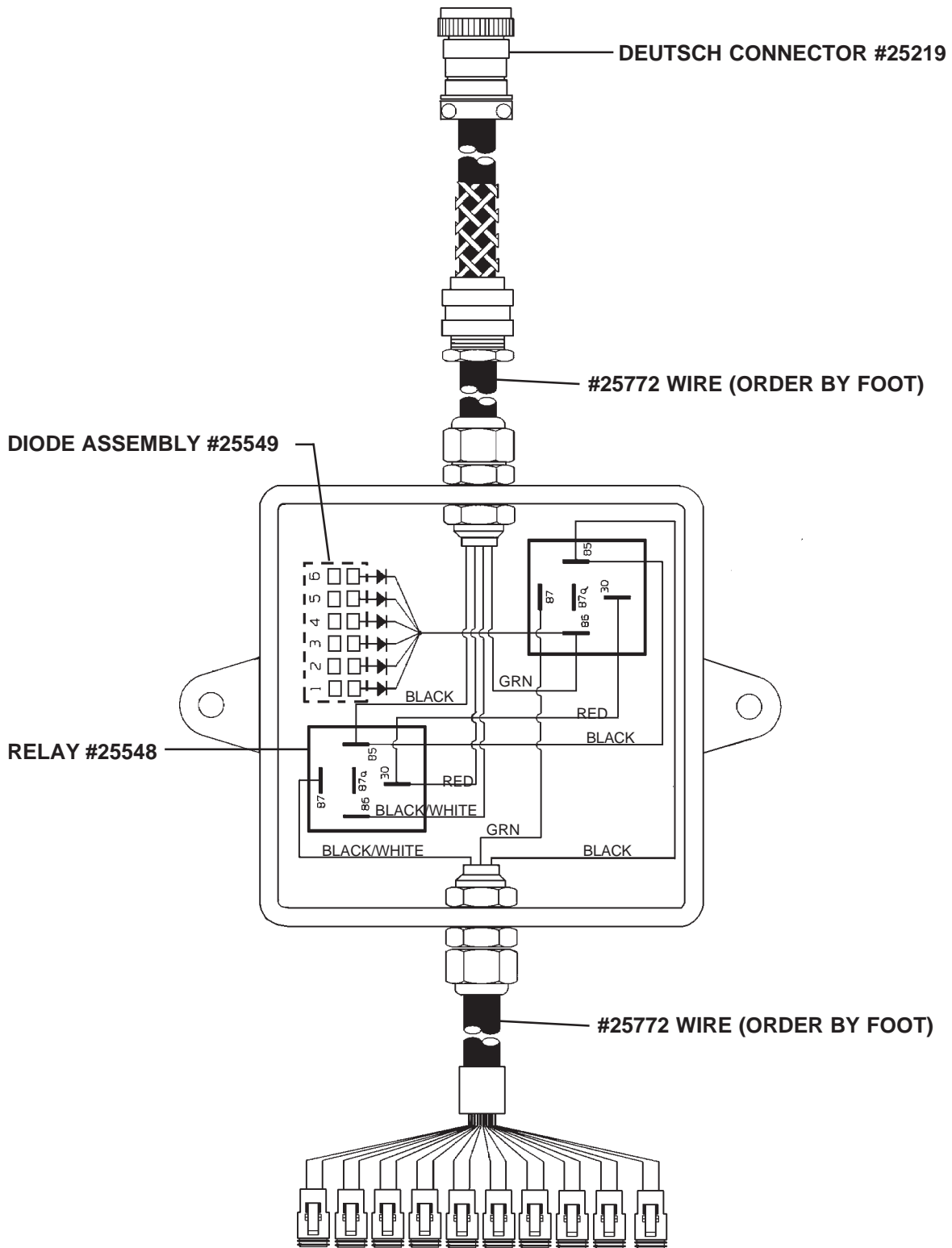

**WIRE TERMINAL PLUG #25551**  
 (INCLUDES: (2) SOCKETS, (1) PLUG & (1) WEDGE LOCK)

# WIRING SCHEMATIC

12' EXTENSION CABLE ASSEMBLY #25519

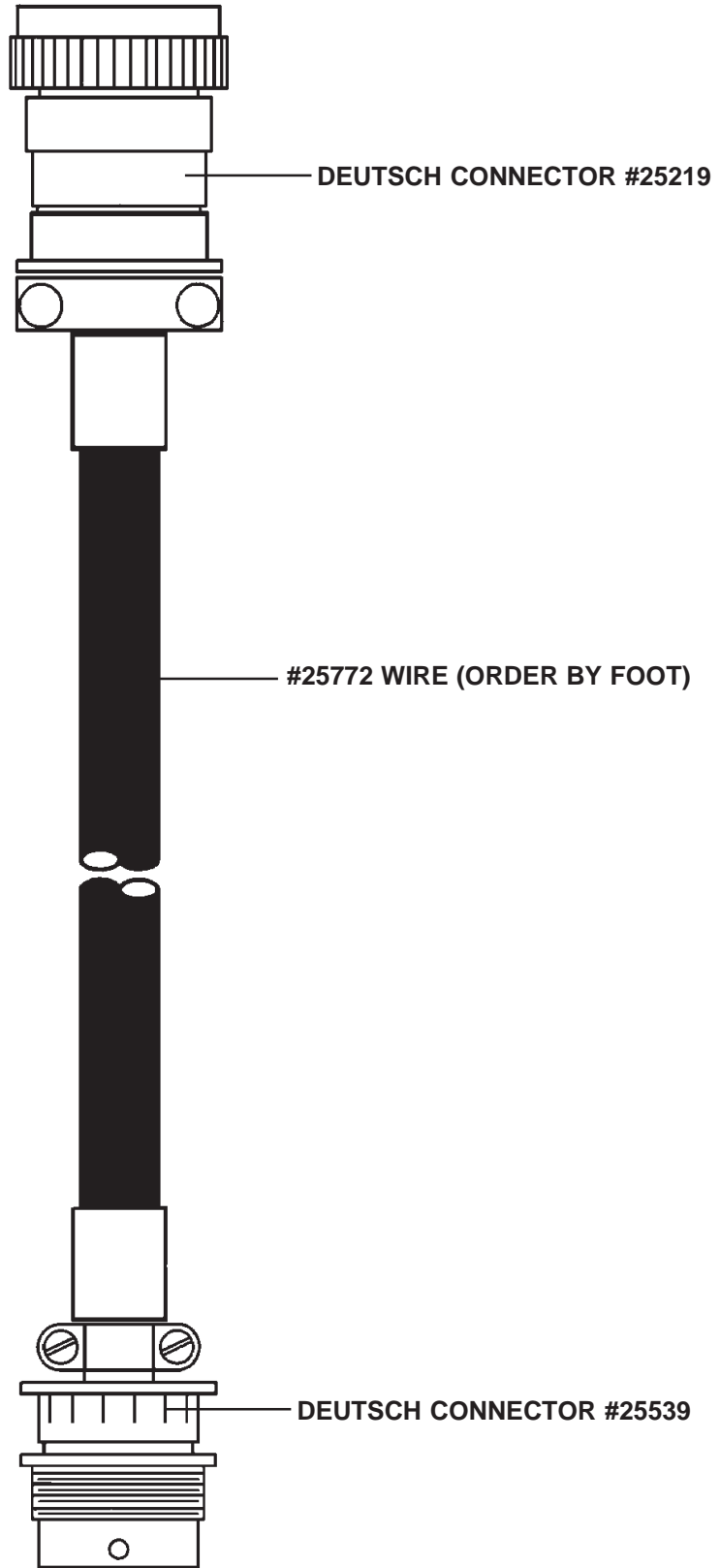

**WIRING SCHEMATIC**

DEUTSCH CONNECTORS

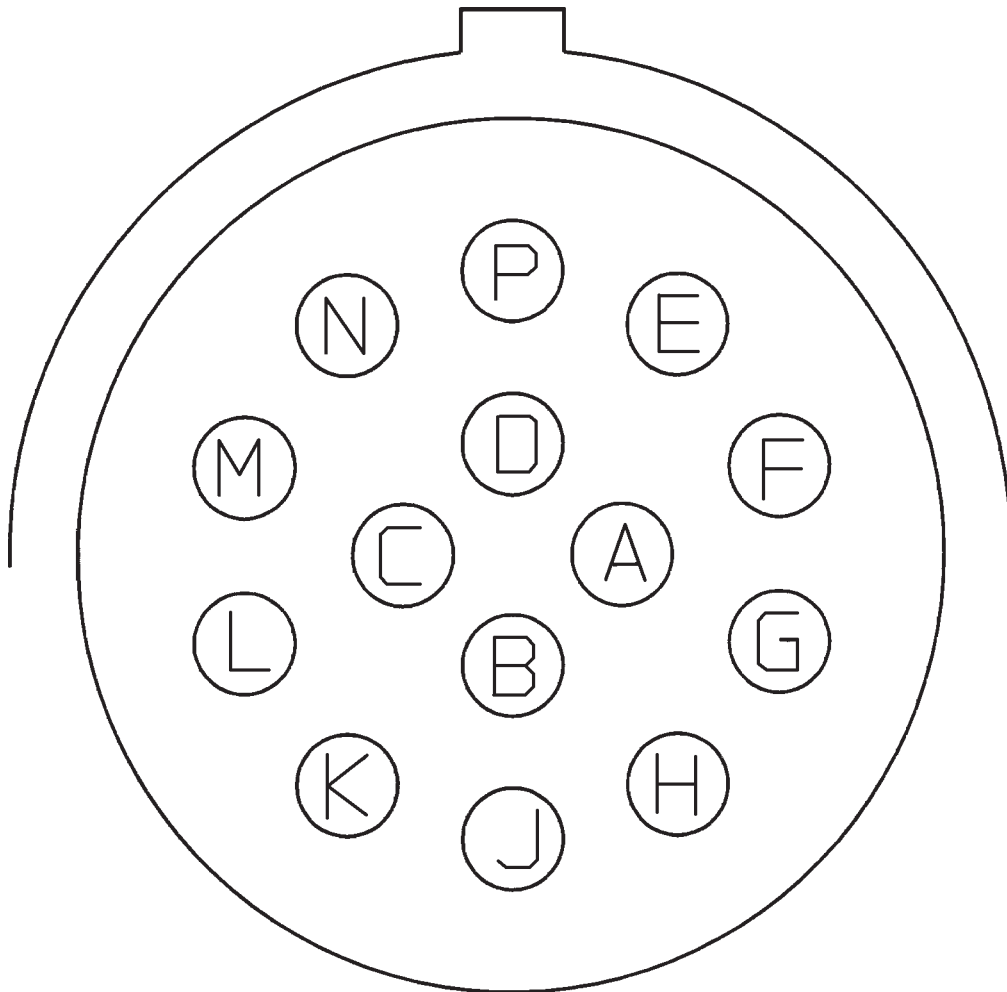
**PIN OUT DETAIL**

- A = GREEN**
- B = BLACK**
- C = RED/BLACK**
- D = GREEN/BLACK**
- E = BLUE/BLACK**
- F = BLUE**
- G = WHITE/BLACK**
- H = ORANGE/BLACK**
- J = BLACK/WHITE**
- K = RED**
- L = ORANGE**
- M = WHITE**
- N = NOT USED**
- P = NOT USED**

**THIS PAGE  
IS INTENTIONALLY  
BLANK**

# INSTALLATION INSTRUCTIONS

## GENERAL INFORMATION

The following instructions will assist you in mounting your tree spade onto your skid-steer loader. The tree spade uses the quick attach mechanism for ease of installation. Therefore, if you know how to attach the loader bucket, attaching the tree spade should prove no problem.

**NOTE: For mounting to other host machines see the specific mounting instructions that are supplied separately.**

Remember to read all safety warnings, decals and operating instructions before operating the skid-steer loader or tree spade.

## MOUNTING INSTRUCTIONS

1. Remove the steel shipping banding from around the tree spade and the skid.
2. Remove any attachment from the front of the skid-steer loader.
3. Set the quick attach locks on the skid-steer toolbar to the unlocked position. Lower the loader arms and tilt the toolbar down low enough to pass under the top lip of the hitch on the mainframe.
4. Following all standard safety practices, start the skid-steer and slowly drive it in back of the attachment. Position the loader so the top of the toolbar under the lip of the hitch on the mainframe.
5. Tilt the toolbar back to hook the attachment onto the toolbar. It may be necessary to lift the loader arms slightly.
6. Set the quick attach locks to the locked position to secure the tree spade onto the loader. It may be necessary to raise lower or tilt the toolbar to properly align so the locking mechanism can be activated.
7. Install your rear stabilizers (if so equipped) by following the instructions that were supplied rear stabilizers for your unit.
8. Connect the power and return hoses for the rear stabilizers to the two bulkhead fittings on the top of the mainframe (directly beside the power and return hoses for the tree spade).
9. With the auxiliary hydraulic system turned off, route the hydraulic hoses over the mainframe and connect them to their proper auxiliary couplers on the loader.
10. Connect the cord assembly (with joystick) to the control cord from the tree spade. Connect the power cord from the joystick control to a power source on the skid-steer.

**NOTE: Some host machines have an auxiliary electrical outlet to plug in the control cord and then use their own joystick controls.**

## DANGER!



## ELECTROCUTION HAZARD

**Provide electrical power to the joystick by following your skid-steer manufacturer's recommended procedures. The electrical circuit must be fused with a 10 amp fuse to prevent machine damage and serious personal injury or death.**

11. The length of control cord extending from the tree spade mainframe to the skid-steer can be adjusted to suit the reach required for your application. (To adjust: Loosen the nut on the strain relief fitting to release the grip of the grommet and either push or pull on the cord to obtain your desired length. Tighten the nut by hand to secure the cord in place. Use plastic ties to secure the control cord to the hydraulic hoses to help keep it from interfering with operation of the tree spade and also to assist in keeping it free from pinching or chafing.)
12. Complete the pre-delivery checklist located in the back of this manual (Section R). Tree Spade installation is now complete.

# OPERATING INSTRUCTIONS

## CONTROLS

### GENERAL INFORMATION

Your tree spade is controlled by a joystick and an electrical valve assembly. Although BRADCO does offer various options for connecting to existing electrical joystick controls, we will be covering the BRADCO operating controls in these instructions. The joystick control consists of 8 momentary toggle switches and is equipped to handle up to five blades, the undercutter, gate and rear stabilizers (if equipped).

### BLADE CONTROLS

The joystick control can accommodate up to five blades and is wired for the number of blades on the tree spade you have purchased. Pushing the toggle switch up will raise that specific blade up, and pushing the toggle switch down will lower that blade. When the toggle switch is released, all movement will stop. If you have purchased a Model 2625 or 3625, the switches for blades number 4 and 5 will be "inoperable". The blade controls are located in the same pattern as the blades on the unit, with blade Number 1 being the closest blade to the operator on the left hand side (left rear blade).

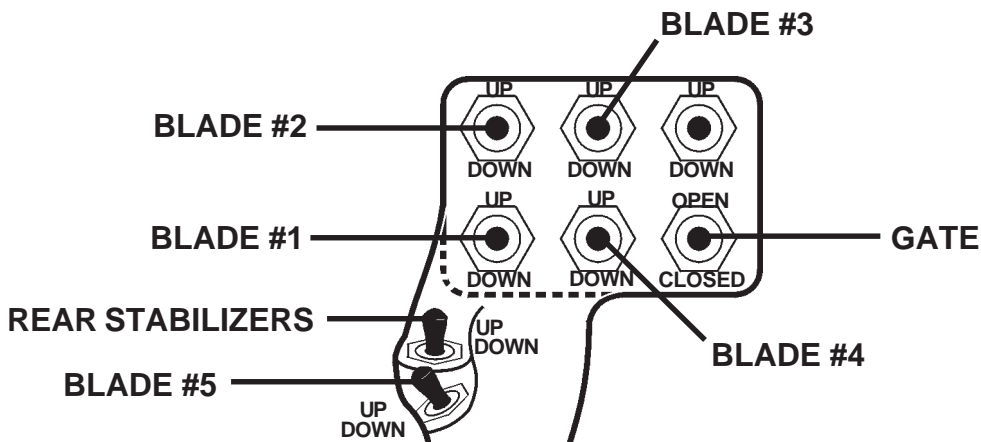

### GATE CONTROL

The gate control operates in the same fashion as the blade controls. Pushing the toggle switch up will open the gates (left and right arms) and pushing the toggle switch down will close the gate. When the toggle switch is released all movement will stop.

# OPERATING INSTRUCTIONS

## CONTROLS

### REAR "JACK" STABILIZER CONTROL

The rear stabilizer control operates in the same fashion as the other controls. Pushing the toggle switch up will raise the left and right stabilizers and pushing the toggle switch down will lower the left and right stabilizer. When the toggle switch is released all movement will stop.

Rear stabilizer kits are available from your BRADCO dealer for fitup to various skid-steer loaders. The rear stabilizer hoses connect to the tree spade control valve and are therefore controlled by the operating control switch on the joystick.

Rear stabilizers are recommended to get the maximum performance from your tree spade. The rear stabilizers allow as much weight as possible to be transferred to the front of the skid-steer and therefore to the tree spade for maximum digging ability.

### GENERAL INFORMATION

The following information will assist you in determining the size of ball needed for the job at hand. These charts (*taken from the American Standard for Nursery Stock - ANSI Z60.1-1996*) are to be used as a guideline only and you should contact your local nursery for more detailed instructions.

**Multi-Stem Trees or Shrubs**

Height	Min. Dia. Ball
4'	14"
5'	16"
6'	18"
7'	20"
8'	22"
10'	24"
12'	28"
14'	32"
16'	38"
18'	42"

**Deciduous Shrubs**

Height	Min. Dia. Ball
12"	8"
18"	9"
2'	10"
3'	12"
4'	14"
5'	16"
6'	18"
7'	20"
8'	22"
9'	24"
10'	26"

**Shade Trees**

Caliper	Min. Dia. Ball
1/2"	12"
3/4"	14"
1"	16"
1-1/4"	18"
1-1/2"	20"
1-3/4"	22"
2"	24"
2-1/2"	28"
3"	32"
3-1/2"	38"
4"	42"

**Small Trees**

(Ht. up to 6' / Caliper 6' & over)

Ht./Caliper	Min. Dia. Ball
2'	10"
3'	12"
4'	14"
5'	16"
3/4"	16"
1"	18"
1-1/2"	20"
1-3/4"	22"
2"	24"
2-1/2"	28"
3"	32"
3-1/2"	38"
4"	42"

**Coniferous Evergreens**

Spreading/Semi-Spreading/Globe/Dwarf

Spread	Min. Dia. Ball
9"	8"
12"	8"
15"	10"
18"	10"
2'	12"
2-1/2'	14"
3'	16"
3-1/2'	18"
4'	21"
5'	24"
6'	28"
7'	32"
8'	36"

**Coniferous Evergreens**

Conical & Broad Uprights

Height	Min. Dia. Ball
12"	10"
18"	10"
2'	12"
3'	14"
4'	16"
5'	20"
6'	22"
7'	24"
8'	27"
9'	30"
10'	34"
12'	34"
14'	42"

# OPERATING INSTRUCTIONS

## Columnar Coniferous Evergreens Regular Growing

Height	Min. Dia. Ball
12"	10"
18"	10"
2'	12"
3'	13"
4'	14"
5'	16"
6'	18"
7'	20"
8'	22"
9'	24"
10'	27"
12'	30"
14'	33"
16'	36"
18'	40"

## Columnar Coniferous Evergreens Rapid Growing

Height	Min. Dia. Ball
12"	8"
2'	9"
3'	11"
4'	12"
5'	14"
6'	16"

## Broadleaf Evergreen Cone and Upright

Height	Min. Dia. Ball
18"	10"
2'	12"
3'	14"
4'	16"
5'	20"
6'	22"
7'	24"
8'	27"
9'	30"
10'	34"
12'	38"
14'	42"

## Broadleaf Evergreen Spreading/Semi-Spreading/ Globe/Dwarf

Spread	Min. Dia. Ball
18"	10"
2'	12"
2-1/2'	14"
3'	16"
3-1/2'	18"
4'	21"

## Processed Balled Fruit Trees

Caliper	Min. Dia. Ball
1/4"	8"
5/16"	8"
3/8"	10"
31/2"	10"
5/8"	10"
3/4"	12"
1" & UP	12"

In sizing shade trees, caliper shall take precedence over height. In size grading small and flowering trees, height shall take precedence up to 6 feet; thereafter, caliper takes precedence.

Caliper of the trunk shall be taken 6 inches above the ground up to and including 4 inch caliper size, and 12 inches above the ground for larger sizes. (Seldom are tree trunks perfectly round. Caliper measurement may be taken with "slot" type caliper, "pincer" type calipers or diameter tape.)

The diameter of the ball is determined by the blade size or the digging depth. Each blade is changed by removing one pin. The ball depth is determined by the position of the adjustable legs.

On larger bushy trees the branches may have to be tied up so the blades do not cut off the lower branches.

On some types of trees it is recommended for best results that transplanting take place while the tree is dormant. Contact your local nursery for the specifications on the type of tree you are transplanting.



---

## OPERATING INSTRUCTIONS

---

The BRADCO Tree Spades are designed to meet the needs of the professional nurseryman. The machine has proven capable of continuous digging with a minimum of maintenance. It is used extensively for removing trees for burlapping and for transplanting and rearranging nursery rows.

**NOTE: These instructions include the use of rear "jack" stabilizers. Rear stabilizer kits are available from your BRADCO dealer for fitup to various skid-steer loaders. The rear stabilizer hoses connect to the tree spade control valve and are therefore controlled by the operating control switch on the joystick. Rear stabilizers are recommended to get the maximum performance from your tree spade. The rear stabilizers allow as much weight as possible to be transferred to the front of the skid-steer and therefore to the tree spade for maximum digging ability.**

**IMPORTANT: Always follow the instructions in your skid-steer loader operators manual for operating the auxiliary hydraulic controls and follow the Safety Shutdown Procedure whenever leaving the operators station of the skid-steer.**

After the tree spade has been properly attached, raise the unit above the ground approximately 2 feet. Acquaint yourself with the various control levers. After becoming familiar with the controls it is advisable to dig in soil without a tree. This will provide an opportunity to check ball size as well as attachment operation.

The blades on the tree spade are number 1, 2, 3 and 4 (if so equipped). The two forward blades open when the gate control is pushed forward. The gates will open and close together.

Soil condition and type affect how the tree spade operates. In firm soil the blades may only travel only one-third of the way down on the first stroke and in loose or sandy soil the blades may penetrate completely in one stroke.

The amount of root ball needed will vary per the diameter of the tree trunk, the height of the tree or the type of tree. Refer to the charts at the beginning of this section. A general rule of thumb is every one inch of tree diameter requires a minimum of ten inch ball diameter.

### **Adjusting Leg Height**

The tree spades are equipped with adjustable legs that are used for adjusting the ball size. With the legs fully raised the ball size will be the rated size of your tree spade. Moving the legs down will decrease the ball size approximately 1.50" for each adjustment hole. If the legs are removed completely the tree spade will dig a slightly larger hole than rated size.

Lift and block the spade before making any leg adjustment.

## OPERATING INSTRUCTIONS

### Balled and Burlapped Trees (with or without Wire Basket)

**NOTE:** There are a wide range of presewn burlap bags, wire baskets and containers available from reputable manufacturers for the BRADCO Tree Spade.

Determine the size of ball required for the type and size of tree. Adjust the legs to achieve the desired ball size.

**CAUTION: TO AVOID CYLINDER DAMAGE:**



**DO NOT OPEN GATES WHEN THE BLADES ARE DOWN.  
DO NOT LOWER BLADES WHEN THE GATES ARE OPEN.**

1. With the gates open and the blades in the up position, center the tree in the tree spade from left to right: and front to back. **NOTE: It is CRITICAL that the tree is centered in the ball. Therefore, it is advisable to have someone on the ground to aid in the alignment process.**
2. Close the gate.
3. Lower the loader arms, therefore raising the front wheels off the ground.
4. Lower the rear stabilizers (if so equipped), until the loader feels level.

**NOTE: Raising the loader until the wheels are only slightly off the ground transfers the weight to the tree spade for maximum digging power. Lifting the loader too high may cause an unstable condition.**

5. Tilt the tree spade until it is level.
6. Once the tree spade is level, the loader raised slightly and the gate closed, it is time to start lowering the blades. Using the joystick control, lower "Blade 1" as far as it will go into the soil. (Due to the different soil conditions the blade may go all the way into the ground or only slightly.)
7. As soon as the blade starts to tilt the attachment, stop movement and raise the blade slightly to remove some of the down pressure. (This will assist in digging the maximum ball size and prevent digging an angled hole.)
8. Using the joystick control, lower "Blade 2" as far as it will go into the soil. As soon as the blade starts to tilt the attachment, stop movement and raise the blade slightly to remove some of the down pressure.
9. Repeat step #8 for "Blade 3" and "Blade 4" (if so equipped).

## OPERATING INSTRUCTIONS

10. If the blades failed to lower completely due to the soil conditions, repeat Steps #6 thru #9 until all the blades are completely lowered into the soil.
11. Raise the rear stabilizers, (if so equipped).
12. Raise the loader arms until the wheels are fully on the ground.
13. Lift the tree out of the hole.
14. Placing the burlap on the ground or in the wire basket, position the tree in the center of the burlap. **NOTE: Carry the tree as low as possible when transporting.**
15. Release the ball by first raising "Blade 4", and continue to raise the blades in reverse order 3, 2, & 1. **NOTE: If the tree ball sticks to the blades, use a shovel to press down on the tree ball to loosen it from the blades.**
16. Lift the tree spade slightly, and open the gates. Back the loader away from the tree. The ball is ready for covering, with no additional shaping necessary.
17. Finish wrapping the tree.

### Direct Transplanting

1. Determine the size of hole needed for the tree you are transplanting, and adjust the legs to achieve the desired hole size.
2. Raise the blades and drive the skid steer to the location that the tree will be planted and position the skid-steer so the loader is as level as possible. Follow Steps 2 thru 12 in the previous instructions (Balled and Burlapped Trees) to dig a spot for the tree.
3. Lift the dirt ball out of the ground and move out of the way for tree transplanting. Set the tree spade on the ground and raise the blades to release the dirt ball. The blades should be raised in reverse order 4, 3, 2 and 1. Open gates.
4. See Steps 1 thru 13 in the previous instructions (Balled and Burlapped Trees) to dig up the desired tree for transplanting.
5. Position the tree over the previously dug hole, and while keeping the tree trunk as vertical as possible, lower the tree.
6. Release the ball by first raising "Blade 4" and continue to raise the blades in reverse order 3, 2, & 1. **NOTE: If the tree ball sticks to the blades, use a shovel to press down on the tree ball to loosen it from the blades.**
7. Lift the tree spade slightly and open the gates. Back the loader away from the tree. **NOTE: Follow any specific transplanting instructions, such as watering and mulching etc., for the type of tree you are transplanting.**

**THIS PAGE  
IS INTENTIONALLY  
BLANK**

# LUBRICATION

## GENERAL INFORMATION

Economical and efficient operation of any machine is dependent upon regular and proper lubrication of all moving parts with a quality lubricant. Neglect leads to reduced efficiency, wear, breakdown, and needless replacement of parts. If any grease fittings are missing, replace them immediately. Clean all fittings thoroughly before using grease gun.

**IMPORTANT: Avoid excessive greasing. Dirt collects on exposed grease and greatly increases wear. After greasing, wipe off excessive grease from fittings.**

**NOTE: A scraping sound during blade operation is an indication that the slide channel and slider bars require lubricating.**

## EVERY EIGHT HOURS OF OPERATION

- (1) Fitting on Gate Pivot Pin - Model 2625 and 3625.
- (2) Fittings on Gate Pivot Pin - Model 4425.
- (2) Fitting on Gate Cylinder - Model 2625 and 3625.
- (4) Fittings on Gate Cylinders - Model 4425.

## LUBRICATION SYMBOLS



Lubricate daily or every 8 hours of operation with SAE Multi-Purpose Lubricant or an equivalent SAE Multi-Purpose type grease.

### Model 4425 Tree Spade shown

GATE PIVOT PIN  
(1 EACH SIDE)

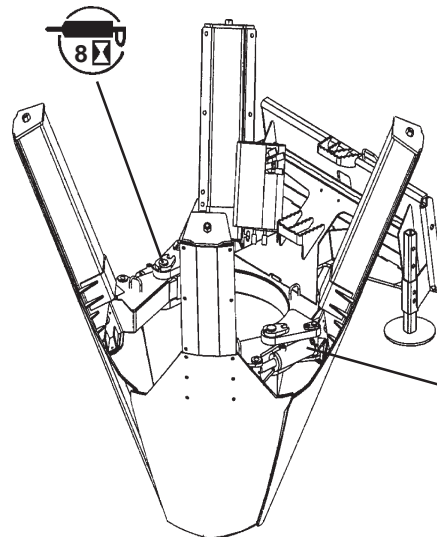

GATE CYLINDER  
(2 EACH CYLINDER)



## MAINTENANCE & SERVICE

### GENERAL INFORMATION

Regular maintenance is the key to long equipment life and safe operation. Maintenance requirements have been reduced to an absolute minimum. However, it is very important that these maintenance functions be performed as described below.

### LUBRICATION

Lubricate all grease fittings with a multi-purpose grease. For grease locations, refer to Section H.

### DAILY

Physically check all pins, bushings, cotter pins, nuts, etc., for signs of wear or loose fit. Tighten as required, replace where necessary.

Clean equipment of all dirt, oil, and excess grease.

Check for missing or illegible Safety / Warning Decals.

Check all fittings and hydraulic hoses for leaks.

**WARNING!** Escaping hydraulic / diesel fluid under pressure can penetrate the skin causing serious injury. Fluid escaping from a very small hole can be almost invisible. Use a piece of cardboard or wood, rather than hands to search for suspected leaks.



Keep unprotected body parts, such as face, eyes, and arms as far away as possible from a suspected leak. Flesh injected with hydraulic fluid may develop gangrene or other permanent disabilities. If injured by injected fluid, see a doctor at once.

Stop the engine and relieve pressure before connecting or disconnecting lines.

Tighten all connections before starting engine or pressurizing lines.

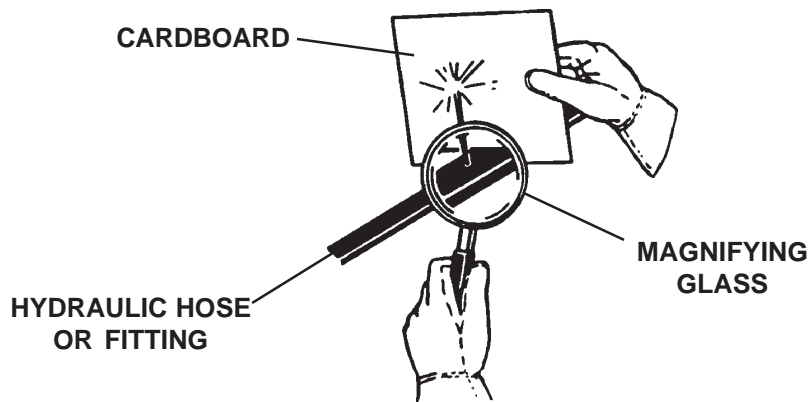

## MAINTENANCE & SERVICE



**WARNING!** Be sure to follow Safety Shutdown Procedures before performing any maintenance on attachment.

### BLADE MAINTENANCE

Maintaining the condition of the blades will result in a cleaner ball and a smoother digging operation. The blades are painted before shipping. This prevents the earth from sticking to the blades and aids in the digging operation. The performance of the blade is affected by soil conditions and can be repainted or coated with Slip Plate #1, manufactured by Acrotech Industries Inc. One gallon of Slip Plate #1 can be purchased from BRADCO under part #25154. It is important that oil not be used on the blades as long as the graphite coating remains.

### SHARPENING BLADES

Although the blades should remain in good condition for a long time, extensive use and rocky soil conditions may dull portions of the blades. If sharpening is required, use a hand grinder and sharpen the blades in an even pattern.

### REPLACING BUSHINGS

#### To Replace Arm Bushings:

1. Lower the mainframe onto the rear legs as close to the ground as possible, and block up the front of the mainframe to keep it level.
2. Remove Blades #2 and #3.
3. Disconnect the gate cylinders at the arm weldments.
4. Attach a hoist to the arm to prevent it from falling and causing personal injury or undue stress to the hoses when it is disconnected from the mainframe.

**NOTE: If you are removing the arm completely for bushing replacement, the blade cylinder hoses will need to be tagged and removed.**

5. With the arm supported, remove the pivot pin securing the arm to the mainframe. While continuing to support the arm, press out the top and bottom bushing and replace with new.
6. Position the arm, and replace the pivot pin.
7. Connect the gate cylinder to the arm weldment.
8. Repeat steps #3 through #7 for the remaining arm (if equipped).
9. Reinstall Blades #2 and #3. Bushing replacement is complete.

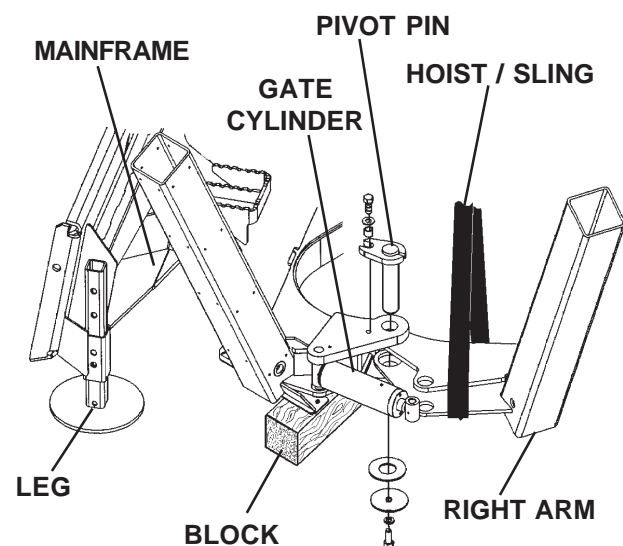

## MAINTENANCE & SERVICE

### BLADE ADJUSTMENT

Proper adjustment of the blades is required for best performance of the tree spade. Loose blades hinder the spades ability to cut the roots. As the blades and plastic wear plates begin to wear, the blades may need to be adjusted to maintain the close positioning of the blades and prevent gapping between the blades. There are shims provided between the tower and the blades and the tower and the tower cover that can be removed (to tighten the tower on the mainframe) or moved to the opposite side (to maintain blade tightness).

#### To adjust blades:

1. Loosen the .50" capscrews securing the tower cover and blades to the tower.
2. Slide in a shim or remove a shim as required to maintain blade tightness.

**(NOTE: Keep all shims for future adjustments.)**

3. Re-tighten capscrews and check the blade positioning.

**NOTE: Once the blades can no longer be adjusted the wear plate(s) will need to be replaced.**

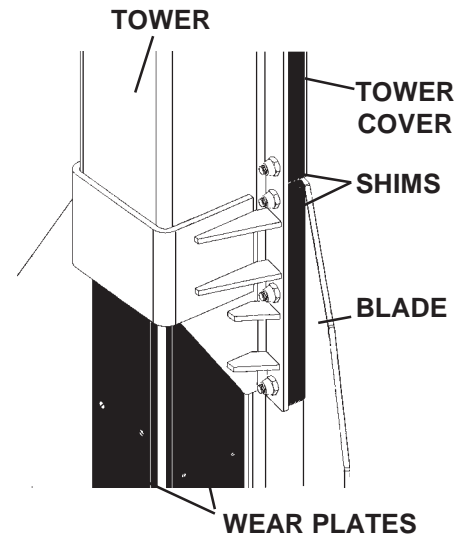

### WEAR PLATE REPLACEMENT

If the wear plate(s) have worn to the point that the towers are riding on the capscrews or when the blades have reached the end of their adjustment and gapping between the blades is still evident the wear plate(s) will need to be replaced.

#### To replace wear plates:

1. Remove the blade and the tower cover from the tower.
2. Position a wrench on the flat spot of the blade cylinder to prevent it from rotating as you remove the lock nut securing the blade to the tower.
3. Remove the tower and inspect the wear plates. Replace any wear plates that are worn. **NOTE: There are two different size wear plates on each slide tower. The front wear plate is shorter than the remaining three.**
4. Re-install the tower and secure the blade cylinder to the tower using the hardware removed in step #2.
5. Install the tower cover to the tower while inserting all of the original shims.
6. Install the blade to the tower while inserting all of the original shims.
7. Check blade position. Insert or remove shims as required to obtain blade tightness.

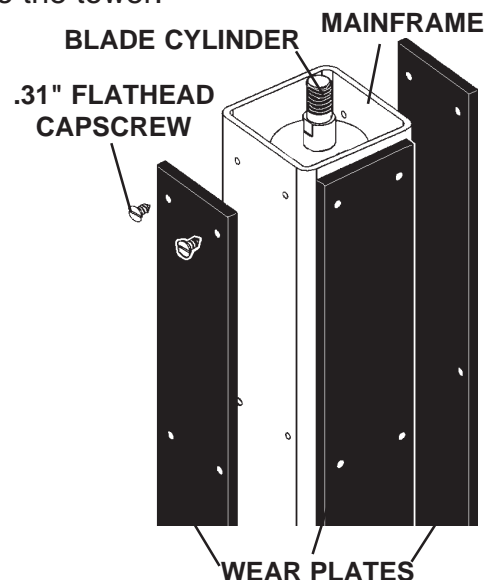



# MAINTENANCE

## CYLINDER SEAL REPLACEMENT

### CYLINDER SEAL REPLACEMENT

#### GENERAL INFORMATION

The following information is provided to assist you in the event you should need to repair or rebuild a hydraulic cylinder. When working on hydraulic cylinders, make sure that the work area and tools are clean and free of dirt to prevent contamination of the hydraulic system and damage to the hydraulic cylinders. Always protect the active part of the cylinder rod (the chrome section). Nicks or scratches on the surface of the rod could result in cylinder failure. Clean all parts thoroughly with a cleaning solvent before reassembly.

#### DISASSEMBLY PROCEDURE

**IMPORTANT:** Do not contact the active surface of the cylinder rod with the vise. Damage to the rod could result.

#### THREADED TYPE GLAND

1. Rotate the gland with a spanner wrench counter-clockwise until the gland is free of the cylinder tube.

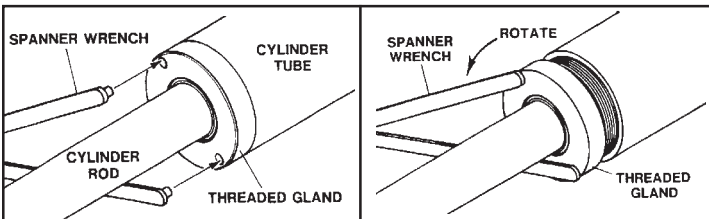

2. Pull the cylinder rod from the cylinder tube.
3. Inspect the piston and the bore of the cylinder tube for deep scratches or galling. If damaged, the piston and cylinder tube must be replaced.

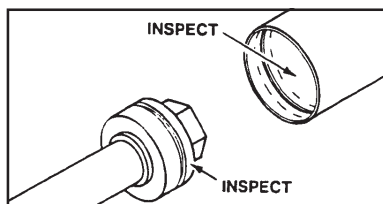

4. Remove the hex nut, piston, flat washer or spacer tube (if so equipped), and gland from the cylinder rod. If the cylinder rod is rusty, scratched, or bent, it must be replaced.

5. Remove and discard all the old seals.

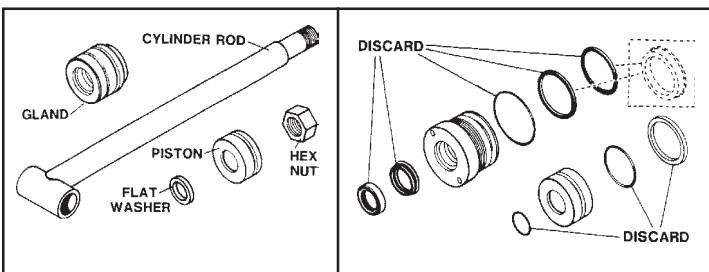

#### ASSEMBLY PROCEDURE

**IMPORTANT:** Replace all seals even if they do not appear to be damaged. Failure to replace all seals may result in premature cylinder failure.

1. Install the cylinder rod seal in the gland first. Be careful not to damage the seal in the process as it is somewhat difficult to install.

A special installation tool (Part #65349) is available to help with installing the seal. Simply fit the end of the tool over the seal so that the large prong of the tool is on the outside of the seal, and the two smaller prongs on the inside. The lip of the seal should be facing towards the tool.

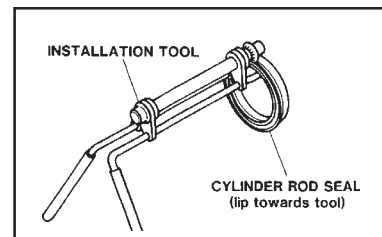

Rotate the handles on the tool around to wrap the seal around the end of the tool.

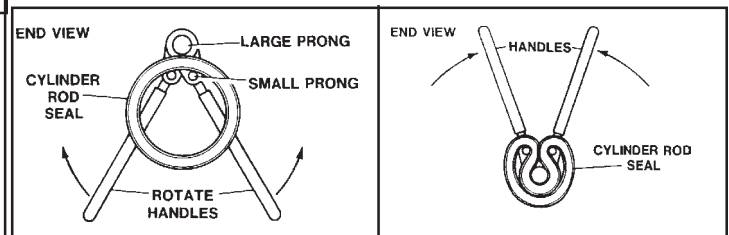

Now insert the seal into the gland from the inner end. Position the seal in its groove, and release and remove the tool. Press the seal into its seat the rest of the way by hand.

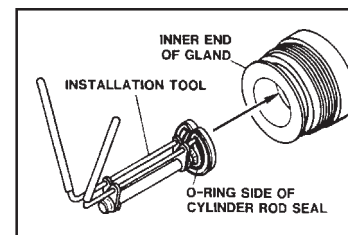

2. Install the new piston ring, rod wiper, O-rings and backup washers if applicable on the piston.

Be careful not to damage the seals. Caution must be used when installing the piston ring. The ring must be stretched carefully over the piston with a smooth, round, pointed tool.

# MAINTENANCE

## CYLINDER SEAL REPLACEMENT

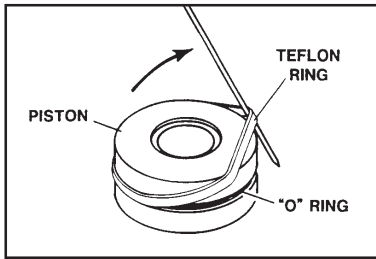

3. After installing the rod seal inside the gland as shown in step #1, install the external seal.

**NOTE:** Threaded glands may have been equipped with a separate O-ring and backup washer system or a polypak (all in one) type seal. Current seal kits contain a polypak (all in one) type seal to replace the discarded seal types on ALL THREADED GLANDS.

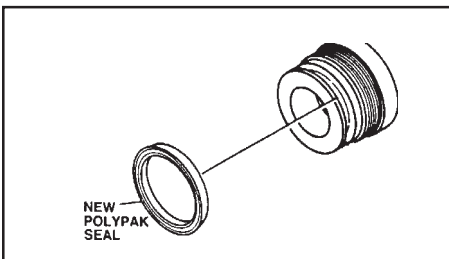

4. Slide the gland onto the cylinder rod being careful not to damage the rod wiper. Then install the spacer, or flat washer (if so equipped), small o-ring, piston, and hex nut onto the end of the cylinder rod.

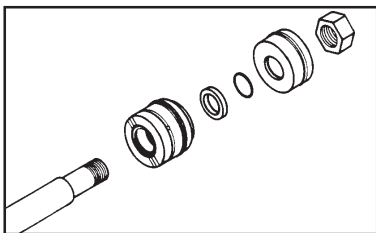

5. Secure the cylinder rod (mounting end) in a vise with a support at it's center. Torque the nut to the amount shown for the thread diameter of the cylinder rod (see chart).

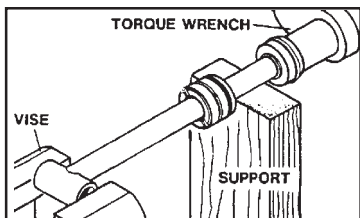

**IMPORTANT:** Do not contact the active surface of the cylinder rod with the vise. Damage to the rod could result.

6. Apply a lubricant (such as Lubriplate #105) to the piston and teflon ring. Insert the cylinder rod assembly into the cylinder tube.

**IMPORTANT:** Ensure that the piston ring fits squarely into the cylinder tube and piston groove, otherwise the ring may be damaged and a leak will occur.

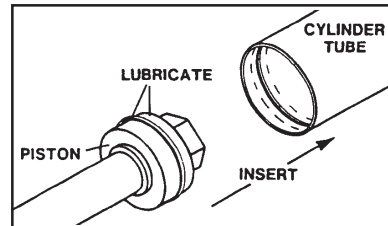

7. Use a spanner wrench to rotate the gland clockwise into the cylinder. Continue to rotate the gland with the spanner wrench until it is tight.

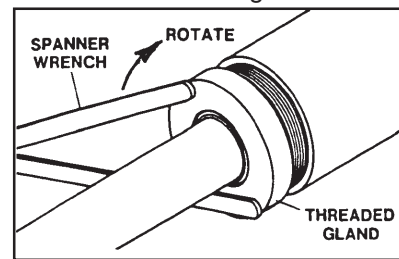

**NOTE:** Seal kits will service most cylinders of similar bore size and rod diameter.

**WARNING!**



Cylinders serviced in the field are to be tested for leakage prior to the attachment being placed in work. Failure to test rebuilt cylinders could result in damage to the cylinder and/or the attachment, cause severe personal injury or even death.

**TORQUE SPECIFICATION CHART**

Use the following torque values when tightening the nuts on the cylinder rod threads.

Thread Diameter	POUNDS - FEET	
	Minimum	Maximum
7/8"	150	200
* 1"	230	325
1-1/8"	350	480
1-1/4"	490	670
1-3/8"	670	900

\* 1" Thread Diameter WITH 1.25" Rod Diameter  
 Min. 230 ft. lbs.      Max. 250 ft. lbs.

---

## STORAGE & TRANSPORTING

---

### GENERAL INFORMATION

The following storage procedure will help you to keep your attachment in top condition. It will also help you get off to a good start the next time your tree spade is needed. We therefore, strongly recommend that you take the extra time to follow these procedures whenever your attachment will not be used for an extended period of time.

### PREPARATION FOR STORAGE

1. Clean the exterior thoroughly removing all mud, dirt and grease.
2. Inspect the unit for visible signs of wear. Order any parts required and make any necessary repairs to avoid delays when starting next season.
3. Inspect the graphite coating on the blades. Repaint as needed.
4. Check the blades for wear. If sharpening is required use a hand grinder.
5. Tighten all loose nuts and capscrews.
6. Grease all grease fittings. (See Section H)
7. Coat the exposed portions of the cylinder rods with grease.
8. Connect the hydraulic couplers together to protect the hydraulic system from contaminants. (Cap the fittings for the rear stabilizers if couplers not used.)
9. Replace decals if damaged or in unreadable condition.
10. Store the unit in a dry and protected place. Leaving the unit outside will materially shorten its life.

### REMOVING FROM STORAGE

1. Remove all protective coverings.
2. Check hydraulic hoses for deterioration and replace if necessary.

### TRANSPORTING

1. Follow all federal, state and local regulations when transporting the unit on public roads.
2. Use extra care when loading or unloading the machine onto a trailer or truck.
3. Before transporting, raise the blades and keep the unit as close to the ground as possible.

**CAUTION!** Be sure to install a SMV (Slow Moving Vehicle) sign on the loader before attempting to transport.



When transporting on a road or highway at night or during the day, use accessory lights and devices for adequate warning to the operators of other vehicles. In this regard, check local government regulations.

Always drive slowly over uneven terrain to avoid tipping the unit.

**THIS PAGE  
IS INTENTIONALLY  
BLANK**

# TROUBLESHOOTING

<u>PROBLEM</u>	<u>POSSIBLE CAUSE</u>	<u>POSSIBLE REMEDY</u>
<b>Tree Spade will not operate.</b>	Auxiliary hoses not hooked up to the skid-steer.	Engage Couplers
	Obstruction in hydraulic lines.	Remove obstruction and replace if necessary.
	Skid-steer auxiliary valve not engaged.	Engage auxiliary valve.
	Loss of electrical power to joystick control.	Check electrical connection and circuit fuse.
<b>Blades activate sluggishly.</b>	Insufficient hydraulic flow from the skid-steer.	Refer to skid-steer's owners manual.
	Damaged quick coupler.	Replace if necessary.
	Oil filter on skid-steer is dirty.	Refer to skid-steer's owners manual.
<b>Leaking Oil.</b>	Loose or damaged hydraulic line.	Tighten or replace.
	O-Rings on fittings damaged.	Replace if necessary.
	Fittings loose or damaged.	Tighten or replace.
	Cylinder seals damaged.	Replace cylinder seals.
<b>Insufficient power.</b>	Insufficient hydraulic flow from the skid-steer.	Refer to skid-steer's owners manual.
	Relief valve setting adjusted too low.	Refer to skid-steer's owners manual.
	Oil filter on skid-steer is dirty.	Refer to skid-steer's owners manual.
	Blades or Undercutter worn or chipped.	Sharpen as needed.
<b>Cylinders operate in the wrong direction.</b>	Hoses from the valve to the skid-steer incorrectly connected.	Switch couplers at the skid steer end.
	Incorrect wiring from the joystick control.	Check wiring diagram and correct.

## TROUBLESHOOTING

<u>PROBLEM</u>	<u>POSSIBLE CAUSE</u>	<u>POSSIBLE REMEDY</u>
<b>Excessive oil temperature.</b>	Hydraulic oil level too low.	Refer to skid-steer's owners manual
	Obstruction in hydraulic lines.	Remove obstruction and replace if necessary.
	Hydraulic oil or oil filter in skid-steer is dirty.	Refer to skid-steer's owners manual.
	Relief valve setting adjusted too low.	Refer to skid-steer's owners manual.
	Couplers not engaged.	Engage couplers.
<b>A hydraulic cylinder not operating.</b>	Insufficient hydraulic flow from the skid-steer.	Refer to skid-steer's owners manual.
	Cylinder rod bent.	Visually inspect the cylinder for damage.
	Cylinder seals damaged.	Replace cylinder seals.
	Obstruction in hydraulic lines.	Remove obstruction and replace if necessary.
	An electrical coil not functioning at valve.	Check voltage readings at valve and replace coil if necessary.
<b>All hydraulic cylinders not functioning.</b>	Blown fuse on skid-steer.	Refer to skid-steer's owners manual.
	Damaged electrical wiring.	Test and replace if necessary.
	Loss of hydraulic power.	Check hydraulic circuit.
	Electrical power connected to wrong polarity.	Reverse red and black wires.
<b>Hydraulic cylinders only operating in one direction.</b>	Contaminants in the hydraulic system and solenoid valve.	Remove spool from solenoid valve and check for foreign material. Clean or replace.  Remove spool from solenoid valve and check seals for damage. Replace if necessary.
	Damaged electrical wiring.	Test and replace if necessary.
	Bad electrical connection at Reversing valve.	Check connections and correct.
	Coil or spool damaged in reversing valve.	Replace as necessary.



# BOLT TORQUE

## BOLT TORQUE SPECIFICATIONS

### GENERAL TORQUE SPECIFICATION TABLE

Use the following torques when special torques are not given. These values apply to fasteners as received from suppliers, dry, or when lubricated with normal engine oil. They do not apply if special graphited or moly disulphide greases or other extreme pressure lubricants are used. This applies to both UNF and UNC threads. Remember to always use grade five or better when replacing bolts.

SAE Grade No.		2				5				8*			
Bolt head identification marks as per grade. NOTE: Manufacturing Marks Will Vary													
		TORQUE		TORQUE		TORQUE		TORQUE		TORQUE		TORQUE	
Bolt Size		Pounds Feet		Newton-Meters		Pounds Feet		Newton-Meters		Pounds Feet		Newton-Meters	
Inches	Millimeters	Min.	Max.	Min.	Max.	Min.	Max.	Min.	Max.	Min.	Max.	Min.	Max.
1/4	6.35	5	6	6.8	8.13	9	11	12.2	14.9	12	15	16.3	30.3
5/16	7.94	10	12	13.6	16.3	17	20.5	23.1	27.8	24	29	32.5	39.3
3/8	9.53	20	23	27.1	31.2	35	42	47.5	57.0	45	54	61.0	73.2
7/16	11.11	30	25	40.7	47.4	54	64	73.2	86.8	70	84	94.9	113.9
1/2	12.70	45	52	61.0	70.5	80	96	108.5	130.2	110	132	149.2	179.0
9/16	14.29	65	75	88.1	101.6	110	132	149.2	179.0	160	192	217.0	260.4
5/8	15.88	95	105	128.7	142.3	150	180	203.4	244.1	220	264	298.3	358.0
3/4	19.05	150	185	203.3	250.7	270	324	366.1	439.3	380	456	515.3	618.3
7/8	22.23	160	200	216.8	271.0	400	480	542.4	650.9	600	720	813.6	976.3
1	25.40	250	300	338.8	406.5	580	696	786.5	943.8	900	1080	1220.4	1464.5
1-1/8	25.58	-	-	-	-	800	880	1084.8	1193.3	1280	1440	1735.7	1952.6
1-1/4	31.75	-	-	-	-	1120	1240	1518.7	1681.4	1820	2000	2467.9	2712.0
1-3/8	34.93	-	-	-	-	1460	1680	1979.8	2278.1	2380	2720	3227.3	3688.3
1-1/2	38.10	-	-	-	-	1940	2200	2630.6	2983.2	3160	3560	4285.0	4827.4

\* Thick Nuts must be used with Grade 8 bolts

### METRIC BOLT TORQUE SPECIFICATIONS

Size of Screw	Grade No.	Coarse Thread			Fine Thread		
		Ptich (mm)	Pounds Feet	Newton-Meters	Pitch (mm)	Pounds Feet	Newton-Meters
M6	5.6	1.0	3.6-5.8	4.9-7.9	-	-	-
	8.8		5.8-9.4	7.9-12.7		-	-
	10.9		7.2-10	9.8-13.6		-	-
M8	5.6	1.25	7.2-14	9.8-19	1.0	12-17	16.3-23
	8.8		17-22	23-29.8		19-27	25.7-36.6
	10.9		20-26	27.1-35.2		22-31	29.8-42
M10	5.6	1.5	20-25	27.1-33.9	1.25	20-29	27.1-39.3
	8.8		34-40	46.1-54.2		35-47	47.4-63.7
	10.9		38-46	51.5-62.3		40-52	54.2-70.5
M12	5.6	1.75	28-34	37.9-46.1	1.25	31-41	42-55.6
	8.8		51-59	69.1-79.9		56-68	75.9-92.1
	10.9		57-66	77.2-89.4		62-75	84-101.6
M14	5.6	2.0	49-56	66.4-75.9	1.5	52-64	70.5-86.7
	8.8		81-93	109.8-126		90-106	122-143.6
	10.9		96-109	130.1-147.7		107-124	145-168
M16	5.6	2.0	67-77	90.8-104.3	1.5	69-83	93.5-112.5
	8.8		116-130	157.2-176.2		120-138	162.6-187
	10.9		129-145	174.8-196.5		140-158	189.7-214.1
M18	5.6	2.0	88-100	119.2-136	1.5	100-117	136-158.5
	8.8		150-168	203.3-227.6		177-199	239.8-269.6
	10.9		175-194	237.1-262.9		202-231	273.7-313
M20	5.6	2.5	108-130	146.3-176.2	1.5	132-150	178.9-203.3
	8.8		186-205	252-277.8		206-242	279.1-327.9
	10.9		213-249	288.6-337.4		246-289	333.3-391.6

**THIS PAGE  
IS INTENTIONALLY  
BLANK**



# SPECIFICATIONS

## 25 SERIES TREE SPADES

SPECIFICATION AND DESIGN ARE SUBJECT TO CHANGE WITHOUT NOTICE AND WITHOUT LIABILITY THEREFORE.

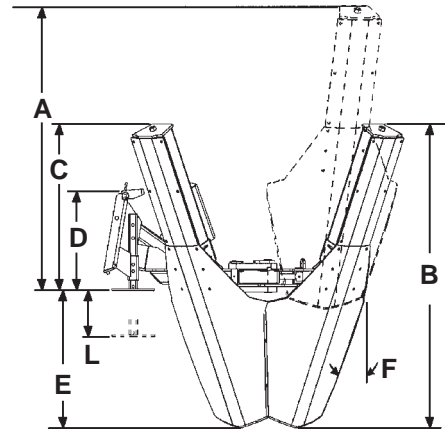

**2625 & 3625**

**4425**

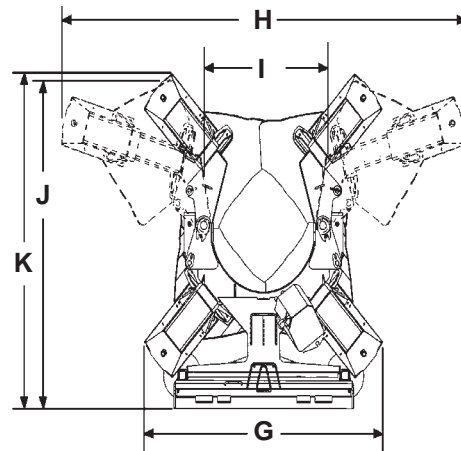
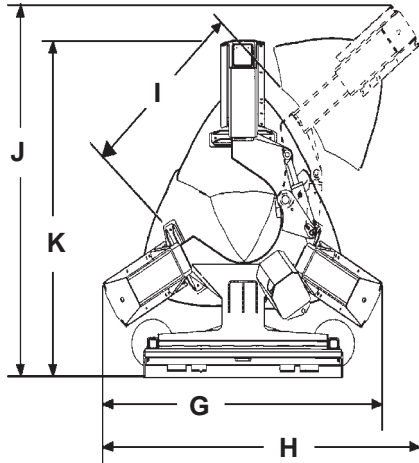

DESCRIPTION	2625	3625	4425
A. Overall Height - Blades Up (Open)	51.00"	64.50"	64.50"
B. Overall Height - Blades Down (Closed)	53.50"	69.00"	69.00"
C. Shipping Height - (Blades Removed)	32.00"	38.00"	38.00"
D. Frame Height	22.50"	22.50"	22.50"
E. Digging Depth	22.00"	31.00"	31.00"
F. Cutting Angle	25°	25°	25°
G. Overall Transport Width (Gate Closed)	51.00"	66.00"	63.00"
H. Overall Width (Gate Open)(Blades Up)	66.50"	88.50"	107.00"
I. Maximum Gate Opening	29.00"	40.00"	33.00"
J. Overall Length (Gate Open)	64.00"	75.00"	68.00"
K. Overall Transport Length (Gate Closed)	63.00"	68.00"	69.50"
L. Maximum Leg Adjustment	10.50"	10.50"	10.50"
Number of Blades	3	3	4
Tree Ball Diameter	18" to 26"	24" to 36"	30" to 44"
Tree Diameter	1.50"-2.50"	2.00"-3.50"	3.00"-4.50"
Ball Weight (LBS)	150#-500#	250#-1000#	1200#-1400#
Flow Requirements (GPM)	10	10	10
Recommended Operating Pressure (PSI)	2250	2250	2250
Weight (LBS)	1100#	1500#	1825#

# DECALS

## DECAL PLACEMENT

### GENERAL INFORMATION

The diagram on this page shows the location of the decals used on the BRADCO Tree Spades. The decals are identified by their part numbers, with reductions of the actual decals located on the following pages. Use this information to order replacements for lost or damaged decals. Be sure to read all decals before operating the tree spade. They contain information you need to know for both safety and attachment longevity.

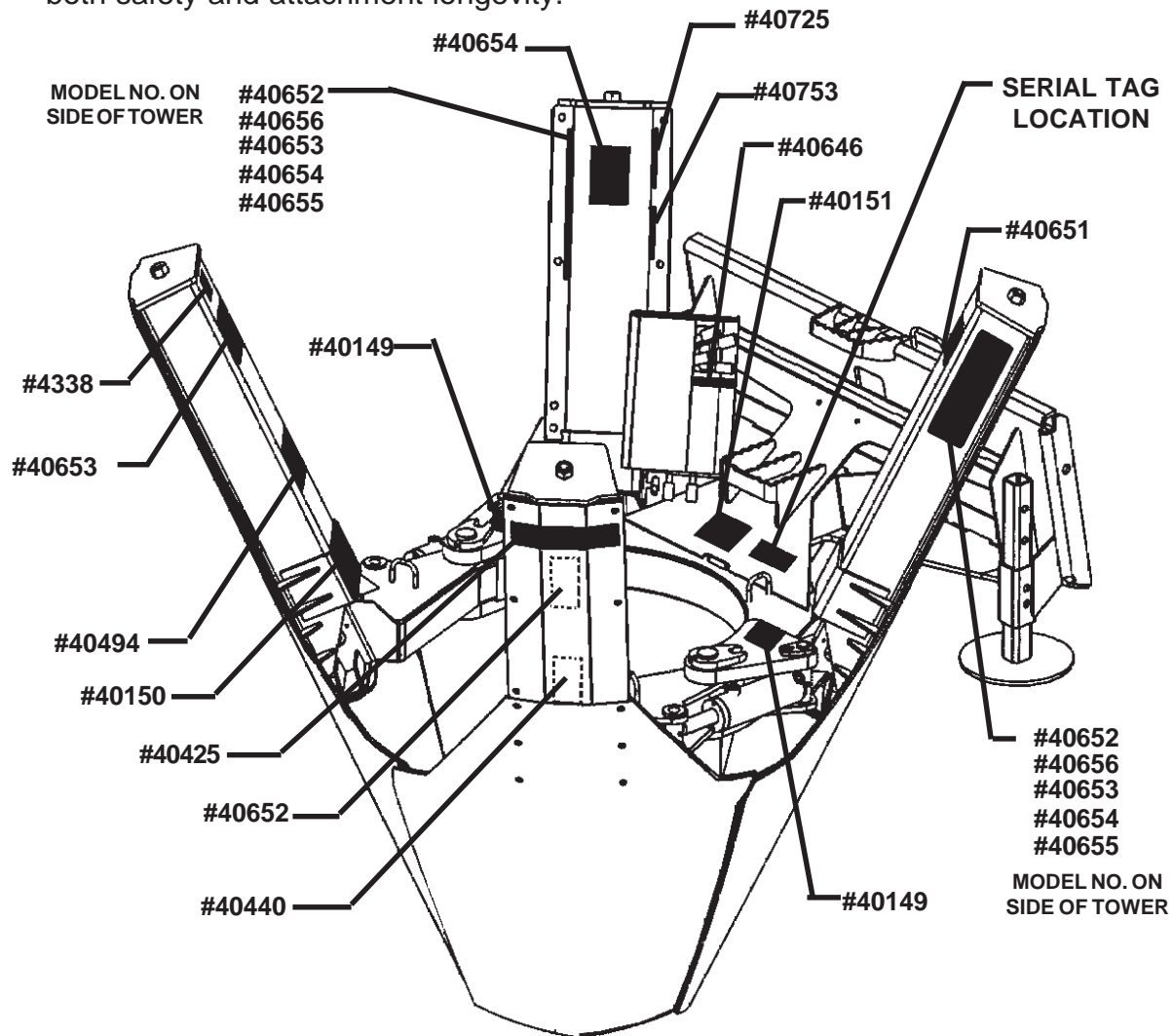

**IMPORTANT:** Keep all safety signs clean and legible. Replace all missing, illegible or damaged safety signs. When replacing parts with safety signs attached, the safety signs must also be replaced.

**REPLACING SAFETY DECALS:** Clean the area of application with a nonflammable solvent, then wash the same area with soap and water. Allow the surface to dry. Remove the backing from the safety sign, exposing the adhesive surface. Apply the safety sign to the position shown in the diagram above and smooth out any bubbles.

DECALS

USE NUMBER DECALS FOR BLADE NUMBER AND IN MODEL NUMBER (IF REQUIRED)

1 2 3 4 5 6

NUMBER "1"  
PART #40651

NUMBER "2"  
PART #40652

NUMBER "3"  
PART #40653

NUMBER "4"  
PART #40654

NUMBER "5"  
PART #40655

NUMBER "6"  
PART #40656

**REAR STABILIZER**  
#40646

REAR STABILIZER  
PART #40646

**CAUTION**

TO AVOID CYLINDER DAMAGE:  
DO NOT OPEN GATES WHEN THE  
BLADES ARE DOWN.  
DO NOT LOWER BLADES WHEN THE  
GATES ARE OPEN.

#40753

CAUTION! CYLINDER DAMAGE  
PART #40753

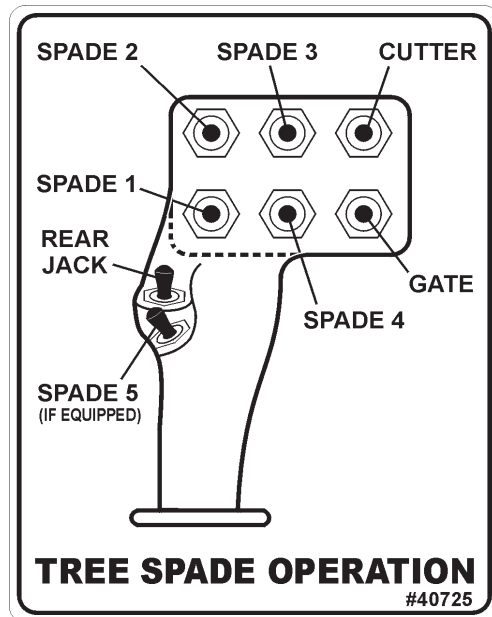

**TREE SPADE OPERATION**  
#40725

OPERATION DECAL  
PART #40725

**BRADCO**®

BRADCO  
PART #40425



MADE IN U.S.A.  
PART #4338

DECALS



DANGER! PINCH POINT  
PART #40149



WARNING! HIGH PRESSURE FLUID  
PART #40151

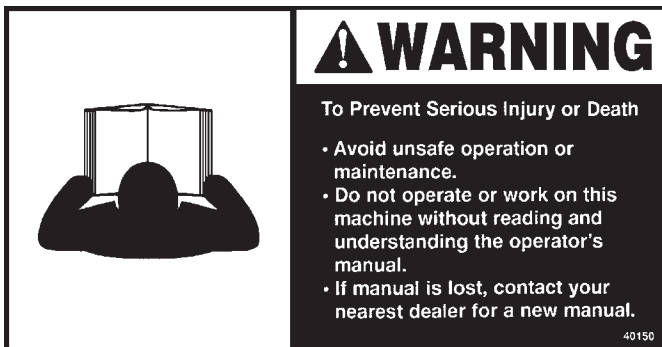

WARNING! READ MANUAL  
PART #40150

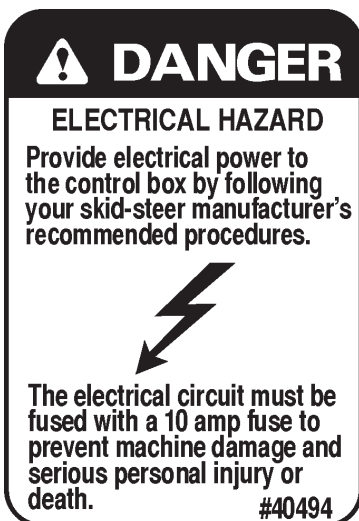

DANGER! ELECTRICAL HAZARD  
PART #40494



CALL BEFORE YOU DIG  
PART #40440

---

## PREDELIVERY CHECKLIST

---

### GENERAL INFORMATION

The following is a list of areas that should be inspected by the dealer prior to delivery of the attachment to the customer. The customer should check the list and make sure that the dealer has completed the inspection. Completion of this checklist will help insure that the customer receives the attachment in complete working order, ready to install.

### PREDELIVERY CHECKLIST - CHECK AND ADJUST AS NECESSARY

1. \_\_\_\_\_ Visually inspect the attachment for bent, cracked, damaged or missing parts. Check for any other irregularities.
2. \_\_\_\_\_ Check and lubricate attachment if necessary. See "Lubrication" Section H.
3. \_\_\_\_\_ Check bolts for tightness daily. Retighten after the first eight working hours.
4. \_\_\_\_\_ Remove paint from unfinished chrome surfaces of cylinders.
5. \_\_\_\_\_ Run cylinders through their full cycle to purge any air from the system.
6. \_\_\_\_\_ Check all hydraulic connections for leaks and hoses for proper positioning to reduce chafing and binding.
7. \_\_\_\_\_ Make sure all decals are not damaged or missing and are in their correct location. See "Decals" Section Q.
8. \_\_\_\_\_ Make sure customer has the necessary couplers to attach the power and return hoses to the skid-steer auxiliary hydraulic couplers.
9. \_\_\_\_\_ Complete and return the manufacturers "Warranty Validation Form" and sign your dealership predelivery checklist.

**THIS PAGE  
IS INTENTIONALLY  
BLANK**

# Limited Warranty

Except for the Excluded Products as described below, all new products are warranted to be free from defects in material and/or workmanship during the Warranty Period, in accordance with and subject to the terms and conditions of this Limited Warranty.

1. Excluded Products. The following products are excluded from this Limited Warranty:

(a) Any cable, part that engages with the ground (i.e. sprockets), digging chain, bearing, teeth, tamping and/or demolition head, blade cutting edge, pilot bit, auger teeth and broom brush that either constitutes or is part of a product.

(b) Any product, merchandise or component that, in the opinion of Paladin Light Construction<sup>1</sup>, has been (i) misused; (ii) modified in any unauthorized manner; (iii) altered; (iv) damaged; (v) involved in an accident; or (vi) repaired using parts not obtained through Paladin Light Construction.

2. Warranty Period. The Limited Warranty is provided only to those defects that occur during the Warranty Period, which is the period that begins on the first to occur of: (i) the date of initial purchase by an end-user, (ii) the date the product is first leased or rented, or (iii) the date that is six (6) months after the date of shipment by Paladin Light Construction as evidenced by the invoiced shipment date (the "Commencement Date") and ends on the date that is twenty-four (24) months after the Commencement Date.

3. Terms and Conditions of Limited Warranty. The following terms and conditions apply to the Limited Warranty hereby provided:

(a) Option to Repair or Replace. Paladin Light Construction shall have the option to repair or replace the product.

(b) Timely Repair and Notice. In order to obtain the Limited Warranty, (i) the product must be repaired within thirty (30) days from the date of failure, and (ii) a claim under the warranty must be submitted to Paladin Light Construction in writing within thirty (30) days from the date of repair.

(c) Return of Defective Part or Product. If requested by Paladin Light Construction, the alleged defective part or product shall be shipped to Paladin Light Construction at its manufacturing facility or other location specified by Paladin Light Construction, with freight PRE-PAID by the claimant, to allow Paladin Light Construction to inspect the part or product.

Claims that fail to comply with any of the above terms and conditions shall be denied.

## **LIMITATIONS AND EXCLUSIONS.**

**THIS LIMITED WARRANTY IS IN LIEU OF ALL OTHER WARRANTIES, EXPRESS OR IMPLIED, INCLUDING WITHOUT LIMITATION THE WARRANTIES OF MERCHANTABILITY, FITNESS FOR A PARTICULAR PURPOSE AND ANY WARRANTY BASED ON A COURSE OF DEALING OR USAGE OF TRADE.**

**IN NO EVENT SHALL PALADIN LIGHT CONSTRUCTION BE LIABLE FOR CONSEQUENTIAL OR SPECIAL DAMAGES.**

**IN NO EVENT SHALL PALADIN LIGHT CONSTRUCTION BE LIABLE FOR ANY LOSS OR CLAIM IN AN AMOUNT IN EXCESS OF THE PURCHASE PRICE, OR, AT THE OPTION OF PALADIN LIGHT CONSTRUCTION, THE REPAIR OR REPLACEMENT, OF THE PARTICULAR PRODUCT ON WHICH ANY CLAIM OF LOSS OR DAMAGE IS BASED. THIS LIMITATION OF LIABILITY APPLIES IRRESPECTIVE OF WHETHER THE CLAIM IS BASED ON BREACH OF CONTRACT, BREACH OF WARRANTY, NEGLIGENCE OR OTHER CAUSE AND WHETHER THE ALLEGED DEFECT IS DISCOVERABLE OR LATENT.**

<sup>1</sup>Attachment Technologies Inc., a subsidiary of Paladin Brands Holding, Inc. (PBHI) is referred to herein as Paladin Light Construction.