



OPERATOR'S AND PARTS MANUAL

BC60, BC72 & BC78 ROTARY CUTTERS



PALADIN LIGHT CONSTRUCTION

UNIVERSAL SKID STEER APPLICATIONS



SERIAL NUMBER: _____

MODEL NUMBER: _____

Manual Number: OM636
Part Number: 75536
Rev. 6

READ ENTIRE OPERATOR'S & PARTS MANUAL BEFORE OPERATING!

DANGER! ROTATING BLADE HAZARD! STAY BACK!



OBJECTS CAN BE THROWN!

DO NOT operate near bystanders.

DO NOT place hands or feet under deck while in operation or with engine running.

DO NOT operate without a shatterproof door (or front shield) installed on loader.

WARNING! Before leaving the operator's seat: Lower the lift arms against frame and



place unit on the ground. Disengage auxiliary hydraulics. Stop Engine.

Engage parking brake. Remove the key.

WARNING! Operating the standard flow rotary cutter on a high flow hydraulic system



may cause severe injury or death to the operator or bystanders due to the increased RPM. Do **NOT** operate the standard flow rotary cutters on high flow hydraulic systems.

WARNING! Lift limiting chain must be properly installed before operation.



WARNING! AVOID STALLING ROTARY CUTTER. During operation, continuous blade



rotation is required to prevent overheating of the hydraulic system. To

monitor the blade rotation, there is a window in the motor cover shield so

the operator can monitor the blade rotation indicator disk. This disk should

always be rotating during operation to prevent overheating of the hydraulic system.

SERVICE

When servicing your rotary cutter, remember to use only manufacturer replacement parts. Substitute parts may not meet the standards required for safe, dependable operation.

To facilitate parts ordering, record the model and serial number of your unit on the cover or in the space provided on this page. This information may be obtained from the identification plate located on the right front of the mounting plate.

MODEL _____

SERIAL NUMBER _____

DATE PURCHASED _____

The parts department needs this information to ensure that you receive the correct parts for your specific model.

TABLE OF CONTENTS

TO THE OWNER	A
SAFETY PRECAUTIONS	B
General Information	
To The Operator	
Before You Start	
Working With The Rotary Cutter	
Transporting the Rotary Cutter	
Maintenance	
INTERNATIONAL SYMBOLS	C
PREOPERATION	D
General Information	
Before Operation	
Skid-Steer	
Major Component Nomenclature	
ROTARY CUTTER ASSEMBLIES	E
60" & 72" Standard Flow Cutter Assemblies	
72" & 78" High Flow Cutter Assemblies	
High Flow Drive Assembly	
High Flow Hydraulic Assemblies	
Wheel Kit Assembly	
INSTALLATION INSTRUCTIONS	F
OPERATING INSTRUCTIONS	G
General Information	
Operating Tips	
Operation	
Troubleshooting Operating Conditions	
LUBRICATION	H
MAINTENANCE	L
Daily	
Every 40 Hours Operation	
Replacing Blades	
Replacing Hydraulic Motor	
Replacing Gearbox/Motor Coupler	
Replacing Gearbox	
STORAGE	M
TROUBLESHOOTING	N
BOLT TORQUE	O
SPECIFICATIONS	P
DECALS	Q
PREDELIVERY CHECK LIST	R
LIMITED WARRANTY	S

TO THE OWNER

GENERAL COMMENTS

Congratulations on the purchase of your new rotary cutter! Your cutter was carefully designed and manufactured to give you years of dependable service. Your cutter will require some minor maintenance (such as cleaning) to keep it in top working condition. Be sure to observe all safety precautions and maintenance procedures as described in this manual.

ABOUT THIS MANUAL

This manual has been designed to help you do a better, safer job. Read this manual carefully and become familiar with its contents. **Remember, never let anyone operate this unit without reading the "Safety Precautions" and "Operating Instructions" sections of this manual. (See Sections B and G respectively.)**

Unless noted otherwise, right and left sides are determined from the position of the skid-steer operator sitting in the seat facing forward.

SAFETY ALERT SYMBOL



This is the "Safety Alert Symbol" used by this industry. This symbol is used to warn of possible injury. Be sure to read all warnings carefully. They are included for your safety and for the safety of others working with you.

SERVICE

When servicing your rotary cutter, remember to use only manufacturer replacement parts. Substitute parts may not meet the standards required for safe, dependable operation.

To facilitate parts ordering, record the model and serial number of your unit in the space provided on this page. This information may be obtained from the identification plate located on the right front of the mounting plate.

MODEL _____
SERIAL NUMBER _____
DATE PURCHASED _____

The parts department needs this information to insure that you receive the correct parts for your specific model.

SAFETY PRECAUTIONS

TAKE NOTE! THIS SAFETY ALERT SYMBOL FOUND THROUGHOUT THIS MANUAL IS USED TO CALL YOUR ATTENTION TO INSTRUCTIONS INVOLVING YOUR PERSONAL SAFETY OR OTHERS. FAILURE TO FOLLOW THESE INSTRUCTIONS CAN RESULT IN INJURY OR DEATH.



THIS SYMBOL MEANS:

ATTENTION!

BECOME ALERT!

YOUR SAFETY IS INVOLVED!

SIGNAL WORDS: Note the use of signal words DANGER, WARNING, and CAUTION with the safety messages. The appropriate signal word for each has been selected using the following guidelines:

DANGER: Indicates an imminently hazardous situation, which if not avoided, will result in death or serious injury. This signal word is to be limited to the most extreme situations, **typically for machine components which, for functional purposes, cannot be guarded.**

WARNING: Indicates a potentially hazardous situation, which if not avoided, could result in death or serious injury, and **includes hazards that are exposed when guards are removed. It may also be used to alert against unsafe practices.**

CAUTION: Indicates a potentially hazardous situation, which if not avoided, **may result in minor or moderate injury. It may also be used to alert against unsafe practices.**

SAFETY PRECAUTIONS

ROTARY CUTTER

GENERAL INFORMATION

This section is composed of various warnings and safety tips. **Read and learn all the information in this section before you attempt to use your rotary cutter.** Also read your vehicle owner's manual before using your equipment. This knowledge will help you operate your unit safely. **Do not take this information lightly, it is presented for your benefit and for the benefit of others working around you.**

The "Safety Alert Symbol" (as described in Section A and at the beginning of Section B) will be used throughout this manual. It will appear with the word **DANGER**, **WARNING**, or **CAUTION** above it, and a safety message pertaining to the specific topic being covered. Take the time to read these messages as you come across them.

TO THE OPERATOR

The primary responsibility for safety with the equipment falls to the operator. Make sure that the equipment is operated only by responsible & competent individuals with the proper instruction. It is the skill, care, common sense, and good judgment of the operator that will determine how efficiently and safely the job is performed. Know your equipment before you start. Know its capabilities, dimensions, and how to operate all the controls. Visually inspect your equipment before you start, and never operate equipment that is not in proper working order.

BEFORE YOU START

1. **Read the entire loader and rotary cutter operator's manuals** before ever attempting to use the loader. This knowledge is necessary for safe operation.
2. **Do NOT operate the standard flow rotary cutter on high flow hydraulic systems. Severe injury or death could occur due to the increased RPM.**
3. **Do not operate without a shatterproof (demolition) cab door or front shield on loader.**
4. **Always wear safety goggles and hearing protection** during operation, and make sure **ALL** safety shields and chains are properly installed.
5. **Follow all safety decals.** Keep them clean and replace them if they become worn, damaged, or illegible.
6. **Do not paint over,** remove, or deface any safety signs or warning decals on your equipment.
7. **Know your equipment inside and out.** Know how to operate all controls and know emergency shut down procedures.
8. **Keep all stepping surfaces, pedals, and controls free from dirt, grease and oil.** Keep equipment clean to help avoid injury from a fall when getting on or off equipment.

SAFETY PRECAUTIONS

ROTARY CUTTER

9. **Use handholds and step plates when getting on/off.** Failure to do so could cause a fall.
10. **Never operate the unit near bystanders, traffic, pets, livestock, or buildings.** Be sure others know when and where you will be working. Make sure no one is behind equipment or for several hundred feet in any direction around the cutter when in operation. Never allow anyone to approach the cutter when in operation.
11. **Never take passengers on your equipment.** There is no safe place for a passenger.
12. **Never try to board equipment while it is running.**
13. **Turn off engine, remove the key and disconnect hydraulic couplers before performing maintenance.** If unit must be left raised for maintenance or any other reason, block the unit securely to prevent accidental release of the lifting mechanism. Serious damage or personal injury could result.
14. **Never leave the unit unattended when in a raised position.** Always make sure both skids are on the ground, and keys removed before leaving the unit unattended.
15. **Test all controls before you begin.**
16. **Do not smoke when refueling.** Allow room in the gas tank for expansion. Wipe up any spilled fuel. Secure cap tightly when done.

WORKING WITH THE ROTARY CUTTER

1. **Never operate the unit without first reading and understanding the operator's manual.**
2. **Never operate the rotary cutter without the lift limiting chain(s) properly installed. Refer to Section F.**
3. **Operate the unit only in daylight, or sufficient artificial light.**
4. **Do not carry load with arms in the raised position.** Always carry loads as close as possible to the ground.
5. **Check your work area, and know where all utility lines are.** Avoid hitting underground electrical wires, cables, pipes, fence posts, gas lines, uneven sidewalk edges, large rocks, etc.
6. **Never operate equipment while under the influence** of alcohol, prescription drugs, nonprescription drugs, or illegal drugs which could inhibit physical and/or mental capacity.
7. **Do not exceed rated operating capacity, as machine may become unstable which may result in loss of control.**
8. **Do not operate the unit without covers and chains installed.**

SAFETY PRECAUTIONS

ROTARY CUTTER

9. **Do not place hands or feet under deck while in operation or with engine running.**
10. **Do not raise the deck when blades are rotating.**
11. **ALWAYS LOWER THE LOADER ARMS TO THE GROUND, SHUT OFF THE ENGINE AND REMOVE THE KEY BEFORE GETTING OFF THE UNIT.**

TRANSPORTING THE ROTARY CUTTER

1. **Follow all federal, state and local regulations when transporting the unit on public roads.**
2. **Use extra care when loading or unloading the machine onto a truck or trailer. Disconnect hydraulic couplers during transportation.**

MAINTENANCE

1. **Never work on equipment while it is running. Always lower the loader arms to the ground,** shut off the engine, remove the key, and disconnect hydraulic couplers before performing maintenance on the unit.
2. **Never make hydraulic repairs while the system is under pressure.** Injury or death could result.
3. **Observe proper maintenance schedules** and repairs to keep the unit in safe working order.
4. **Always wear safety goggles or glasses when working on equipment.**
5. **Use only manufacturer recommended replacement parts.** Other parts may be substandard in fit and quality.

WARNING! Escaping fluid under pressure can have sufficient force to penetrate the skin causing serious personal injury. Fluid escaping from a very small hole can be almost invisible. Use a piece of cardboard or wood, rather than hands to search for suspected leaks.



Keep unprotected body parts, such as face, eyes, and arms as far away as possible from a suspected leak. Flesh injected with hydraulic fluid may develop gangrene or other permanent disabilities.

If injured by injected fluid, see a doctor at once. If your doctor is not familiar with this type of injury, ask him to research it immediately to determine proper treatment.

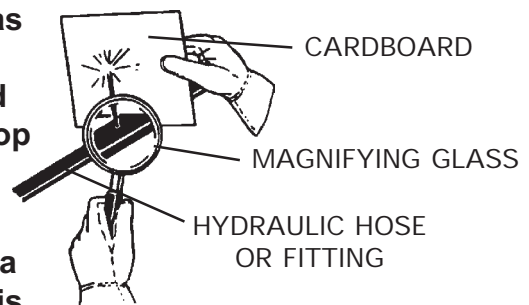

INTERNATIONAL SYMBOLS

As a guide to the operation of your equipment, various international symbols have been utilized on the instruments and controls. The symbols are shown below with an indication of their meaning.

	Engine speed		Alternator charge
	Hours recorded		Power take-off (on)
	Engine water temperature		Power take-off (off)
	Lights		"Tortoise," slow or minimum setting
	Horn		"Hare," fast or maximum setting
	Engine oil pressure		Caution
	Hazard warning		Control lever operating direction
	Axle connect		Rock shaft (raised)
	Axle disconnect		Rock shaft (lowered)
	Continuously variable		Remote cylinder (extended)
	Increase		Remote cylinder (retracted)
	Decrease		Remote cylinder (FLOAT)
	Diesel fuel		Differential lock
	Creeper range		Read operators manual
	High range		Neutral
	Low range		Forward
			Reverse

PREOPERATION

ROTARY CUTTER

GENERAL INFORMATION

The **BRADCO** Rotary Cutters were designed to be easy to use and maintain. They are operated by the skid-steer auxiliary hydraulics. The cutters mount to the toolbar / quick attach mechanism for easy mounting.

Unless noted otherwise, right and left are determined from the position of the skid-steer operator sitting in the operator's seat facing forward.

Remember to read the "Safety Precautions" and "Operating Instructions" sections of the manual **BEFORE** you attempt to install or use the rotary cutter.

NOTE: The illustrations and data used in this manual were current (according to the information available to us) at the time of printing, however, we reserve the right to redesign and change the rotary cutters as may be necessary without notification.

BEFORE OPERATION

The primary responsibility for safety with this equipment falls to the operator. Make sure that the equipment is operated only by trained individuals that have read and understand this manual. Don't hurry the learning process or take the unit for granted. Practice the operation of your new equipment and become familiar with the controls and the way it handles on your machine.

If there is any portion of this manual or function you do not understand, contact your local authorized dealer or the manufacturer.

DANGER! TO AVOID SERIOUS PERSONAL INJURY OR DEATH THE BRADCO ROTARY CUTTER MUST NOT BE ATTACHED TO ANY POWER UNIT THAT DOES NOT HAVE A SHATTERPROOF DOOR (OR FRONT SHIELD) INSTALLED.



WARNING! OPERATING THE STANDARD FLOW ROTARY CUTTER ON A HIGH FLOW HYDRAULIC SYSTEM MAY CAUSE SEVERE INJURY OR DEATH TO THE OPERATOR OR BYSTANDERS DUE TO THE INCREASED RPM. DO NOT OPERATE THE STANDARD FLOW ROTARY CUTTERS ON HIGH FLOW HYDRAULIC SYSTEMS.



SKID-STEER

BRADCO has designed both standard flow and high flow rotary cutters. The standard flow rotary cutters are NOT designed for use on high flow skid-steers. Operating the standard flow on a high flow system will void the rotary cutter warranty. For maximum operation, see the recommended GPM for the rotary cutter you have received.

Your skid-steer must have an auxiliary hydraulic system and a shatterproof door or front shield to run the rotary cutter.

Standard SAE flat face hydraulic quick couplers are supplied with your rotary cutter. If you require an alternate set of couplers, you will need to purchase these from your dealer. These couplers must fit a #12MBo end and connect to your skid-steer auxiliary hydraulic system.

PREOPERATION

ROTARY CUTTER

NOMENCLATURE

Throughout this manual, reference is made to various rotary cutter components. The purpose of this page is to acquaint you with the various names of these components. This knowledge will be helpful when reading through this manual or when ordering service parts.

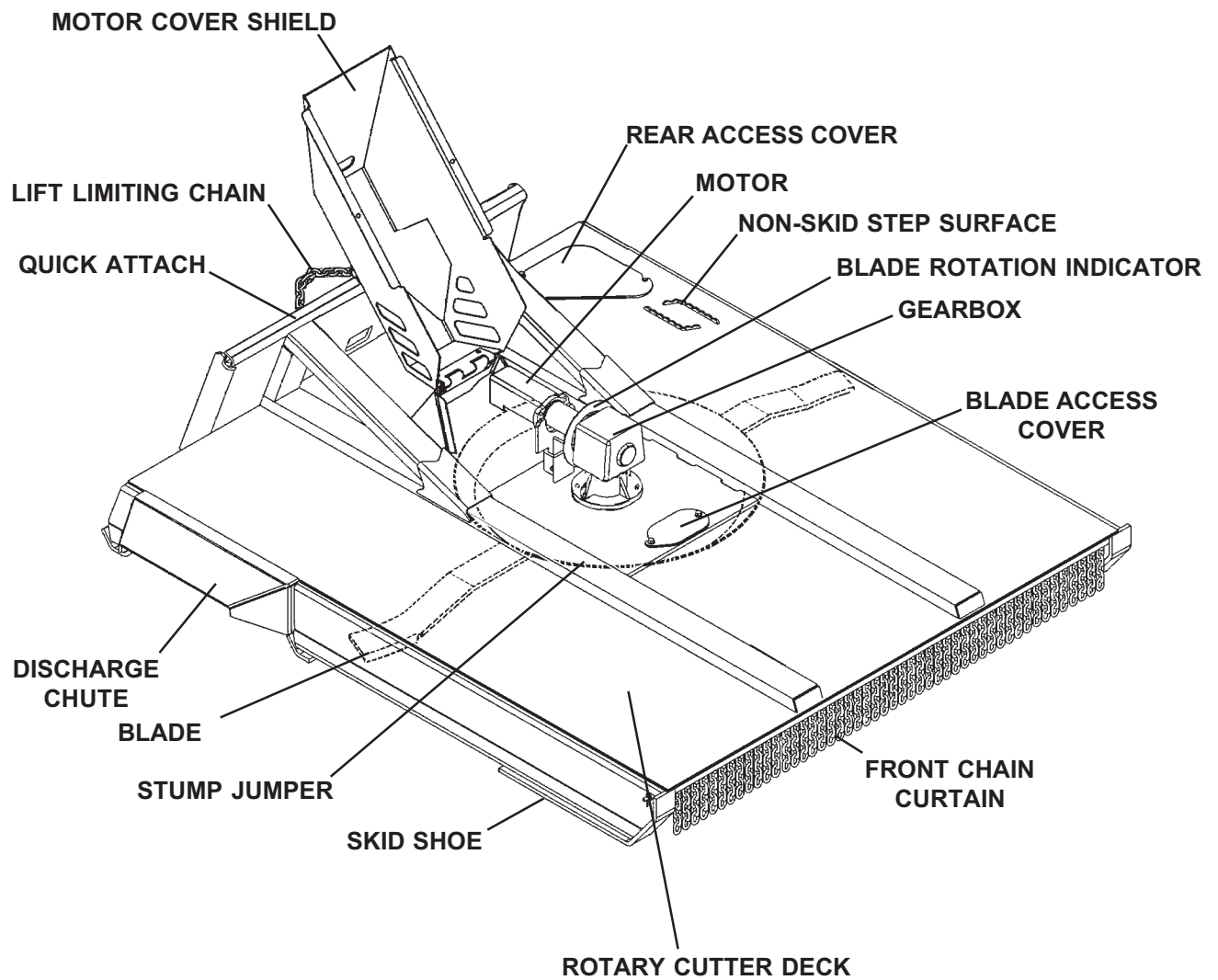

ROTARY CUTTER ASSEMBLY

60" & 72" STANDARD FLOW CUTTER ASSEMBLIES

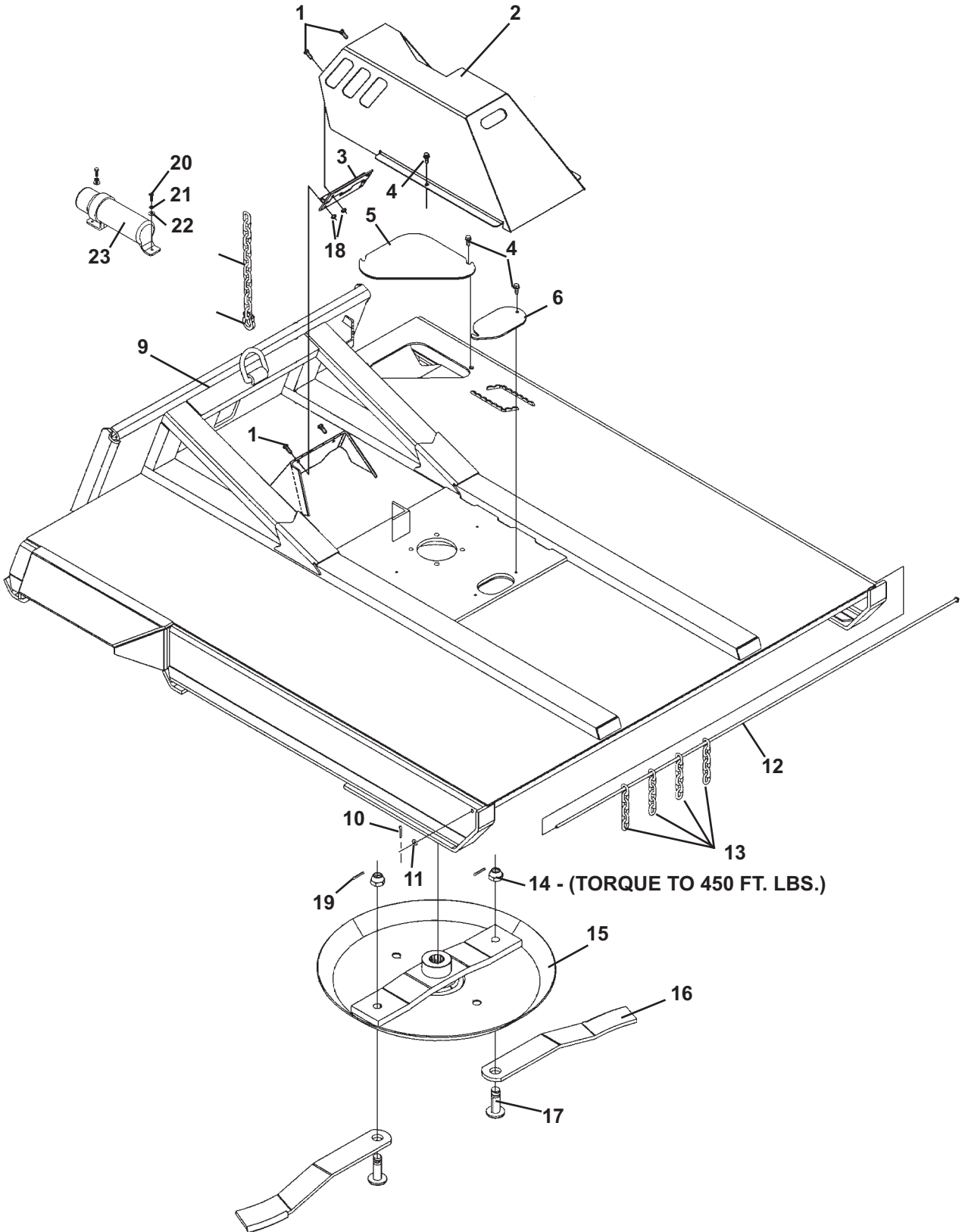

ROTARY CUTTER ASSEMBLY

60" & 72" STANDARD FLOW CUTTER ASSEMBLIES

<u>NO</u>	<u>REQ'D</u>	<u>PART NO.</u>	<u>DESCRIPTION</u>
1	4	1044	.38" UNC x 1.25" Hex Capscrew
2	1	18059	Replacement Cover with Decals
3	1	17941	Hinge
4	6	1953	.38" UNC X .75" Flange Hex Capscrew
5	1	17846	Rear Access Cover
6	1	15321	Blade Access Cover
7	1	18169	Lift Limiting Chain
8	2	89968	Shackle
9	1	17879	60" Cutter
	1	15329	72" Cutter
10	1	1611	Cotter Pin
11	1	1514	.38" Flat Washer
12	1	17902	60" Front Chain Retainer
	1	17348	72" Front Chain Retainer
13	47	15326	Front Chain
	59	15326	Front Chain
14	2	17390	Special Nut (Torque to 450 ft. lbs.)
15	1	17896	60" Stump Jumper Hub
	1	15324	72" Stump Jumper Hub
16	2	18514	Double Edged Blade (60" Rotary Cutter)
	-	17903	Optional Banana Blade (60" Rotary Cutter)
	2	18515	Double Edged Blade (72" Rotary Cutter)
	-	17847	Optional Banana Blade (72" Rotary Cutter)
17	2	17389	Blade Mounting Bolt
18	4	2005510	.38" UNC Flange Lock Nut
19	2	1793	Cotter Pin
20	2	1022	.31" UNC X 1.00 Hex Capscrew
21	2	1502	.31" Lock Washer
22	2	1513	.31" Flat Washer
23	1	25453	Manual Tube

ROTARY CUTTER ASSEMBLY

60" & 72" STANDARD FLOW CUTTER ASSEMBLIES

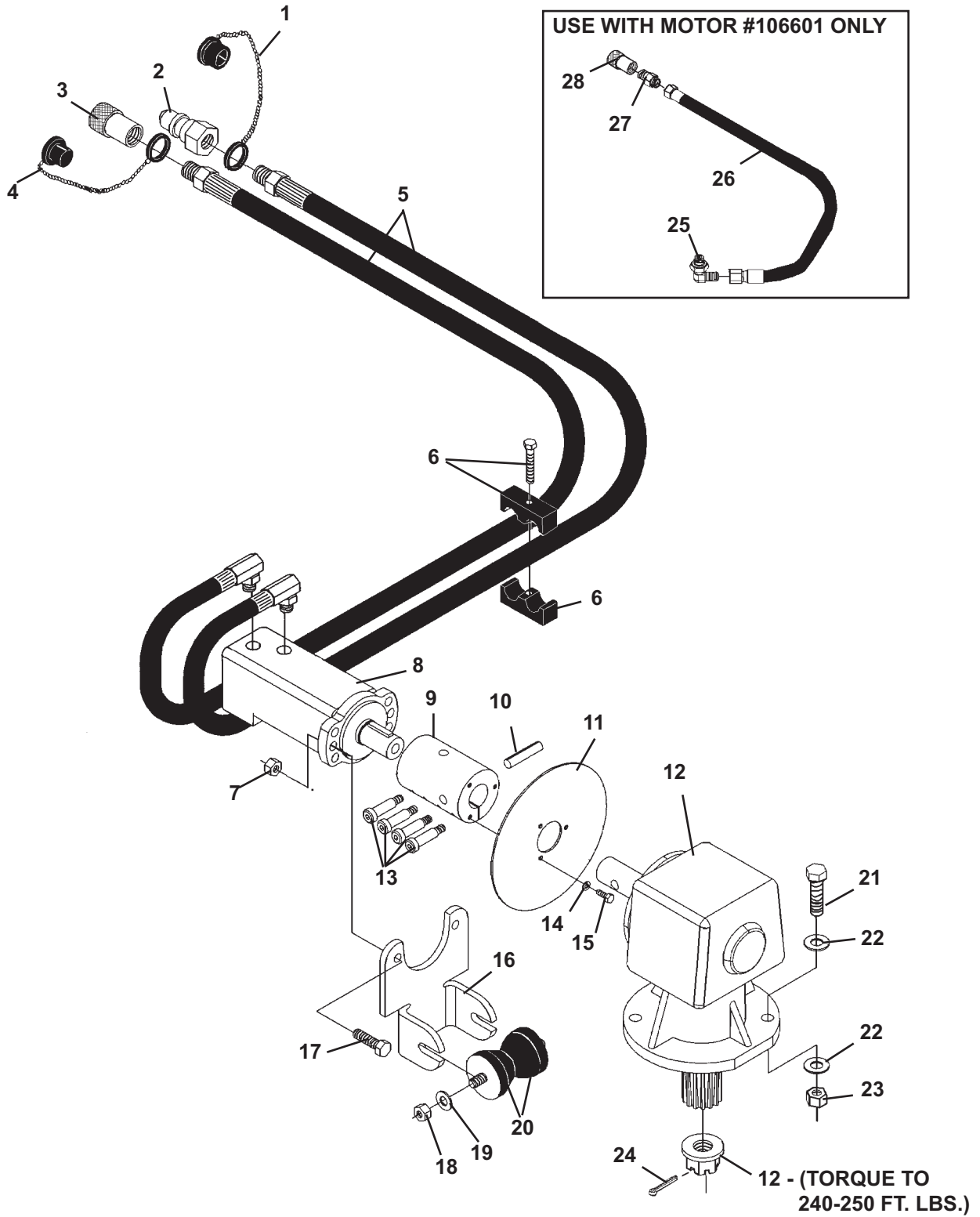

ROTARY CUTTER ASSEMBLY

60" & 72" STANDARD FLOW CUTTER ASSEMBLIES

<u>NO</u>	<u>REQ'D</u>	<u>PART NO.</u>	<u>DESCRIPTION</u>
1	1	17921	Dust Cap
2	1	22519	Male Coupler
3	1	22518	Female Coupler
4	1	17922	Dust Cap
5	2	38081	Hose Assembly .62" x 104" 12MBo-10MBo 90°
6	-	17143	Replacement Hose Clamp
7	2	1841	.50" UNC Deformed Lock Nut
8	1	17938	60" Cutter Hydraulic Motor (6.8 Cu. In.)
	1	17787	72" Cutter Hydraulic Motor (10 Cu. In.)
	1	106601	60" Cutter Hydraulic Motor (25-30 GPM ONLY)
	--	5661	Replacement Key
9	1	17808	Coupler
10	1	22277	Roll Pin
11	1	17843	Blade Rotation Indicator
12	1	15302	Right Angle Gearbox Assembly
	-	19701	Replacement Castle Nut (Torque Castle Nut to 240-250 ft. lbs.)
	-	19702	Replacement Input Seal
	-	19703	Replacement Output Seal
	-	19704	Replacement Vent
13	4	1799	.38" UNC X 1.50" Sockethead Capscrew
14	3	1501	.25" Lock Washer
15	3	1001	.25" UNC X .50" Hex Capscrew
16	1	17844	Motor Mounting Plate
17	2	1091	.50" UNC X 1.75" Hex Capscrew
18	2	1841	.50" UNC Deformed Lock Nut
19	2	1646	.50" Hard Flat Washer
20	2	6886	Rubber Bumper
21	4	10071	.62" UNC X 2.25" Hex Capscrew - Grade 8
22	8	1627	.62" Hard Flat Washer
23	4	1839	.62" UNC Deformed Lock Nut
24	1	1793	Cotter Pin

Use Item 25 through 28 with Motor #106601 ONLY

25	1	3417	90° Elbow 4MBo-6MJ
26	1	37754	Hose Assembly .25" x 116" 6FJX-6FJX
27	1	3269	Straight Connector 8MBo-6MJ
28	1	84928	Female Coupler

ROTARY CUTTER ASSEMBLY

72 & 78" HIGH FLOW CUTTER ASSEMBLIES

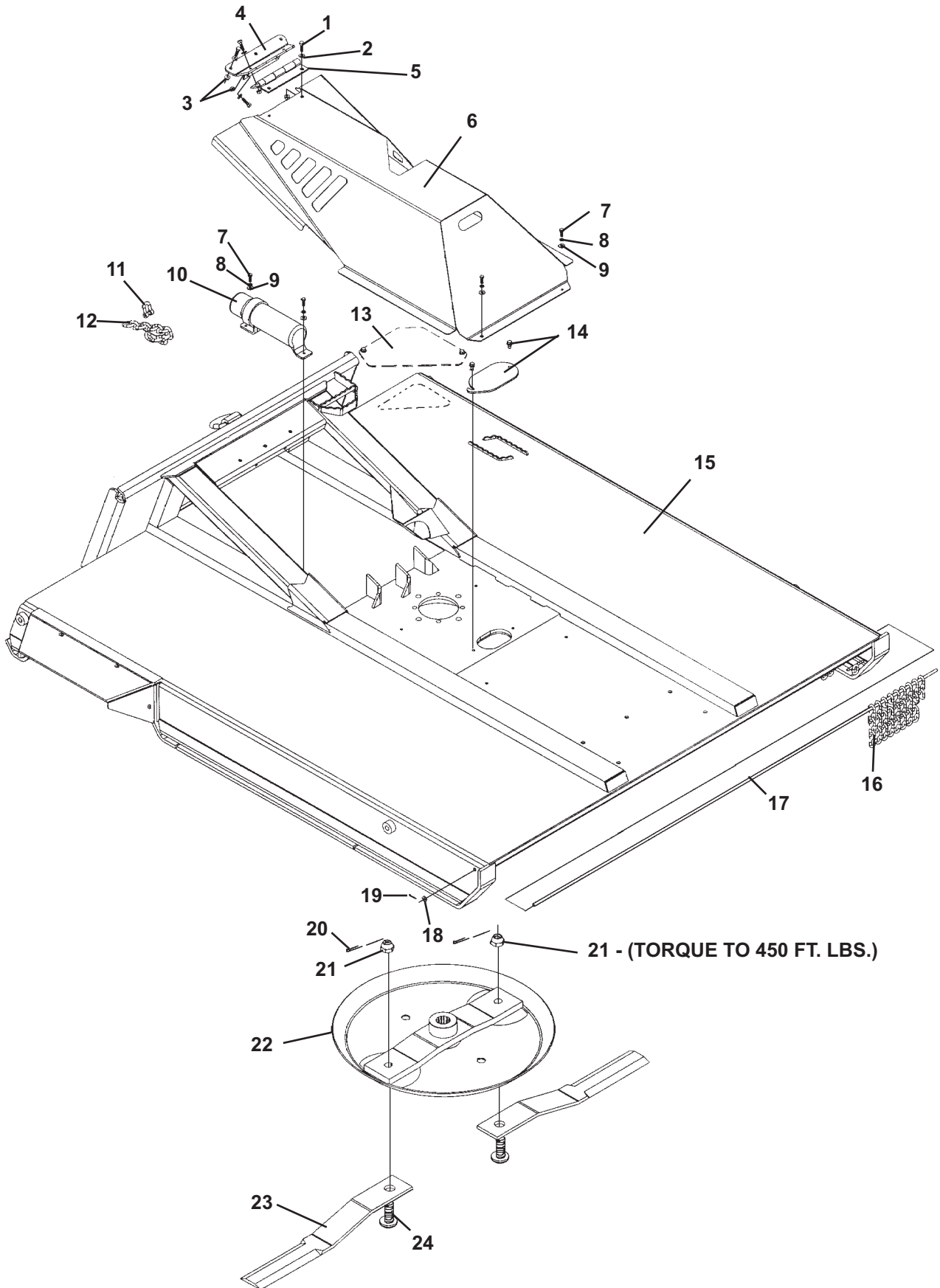

ROTARY CUTTER ASSEMBLY

72 & 78" HIGH FLOW CUTTER ASSEMBLIES

<u>NO</u>	<u>REQ'D</u>	<u>PART NO.</u>	<u>DESCRIPTION</u>
1	9	1044	.38" UNC x 1.25" Hex Capscrew
2	9	1800	.38" Hard Flat Washer
3	9	2005510	.38" UNC Flange Lock Nut
4	1	104420	Hinge Mounting Cover
5	1	17941	Hinge
6	1	108547	Replacement Cover with Decals
7	4	1021	.31" UNC X .75" Hex Capscrew
8	4	1502	.31" Lock Washer
9	4	1513	.31" Flat Washer
10	1	25453	Manual Tube
11	1	89968	Shackle
12	1	18169	Lift Limiting Chain
13	1	17846	Rear Access Cover (72" Cutter ONLY)
	2	1953	.38" UNC X .75" Flange Hex Capscrew
14	1	15321	Blade Access Cover
	2	1953	.38" UNC X .75" Flange Hex Capscrew
15	1	15329	72" Cutter
	1	106299	78" Cutter
16	59	15326	Front Chain (72" Cutter)
	63	15326	Front Chain (78" Cutter)
17	1	17348	72" Front Chain Retainer
	1	106342	78" Front Chain Retainer
18	1	1514	.38" Flat Washer
19	1	1611	Cotter Pin
20	2	1793	Cotter Pin
21	2	17390	Special Nut (Torque to 450 ft. lbs.)
22	1	15324	Stump Jumper Hub
23	2	18515	Double Edged Blade (72" Rotary Cutter)
	-	17847	Optional Banana Blade (72" Rotary Cutter)
	2	106312	Double Edged Blade (78" Rotary Cutter)
24	2	17389	Blade Mounting Bolt

ROTARY CUTTER ASSEMBLY

72 & 78" HIGH FLOW DRIVE ASSEMBLY #104740

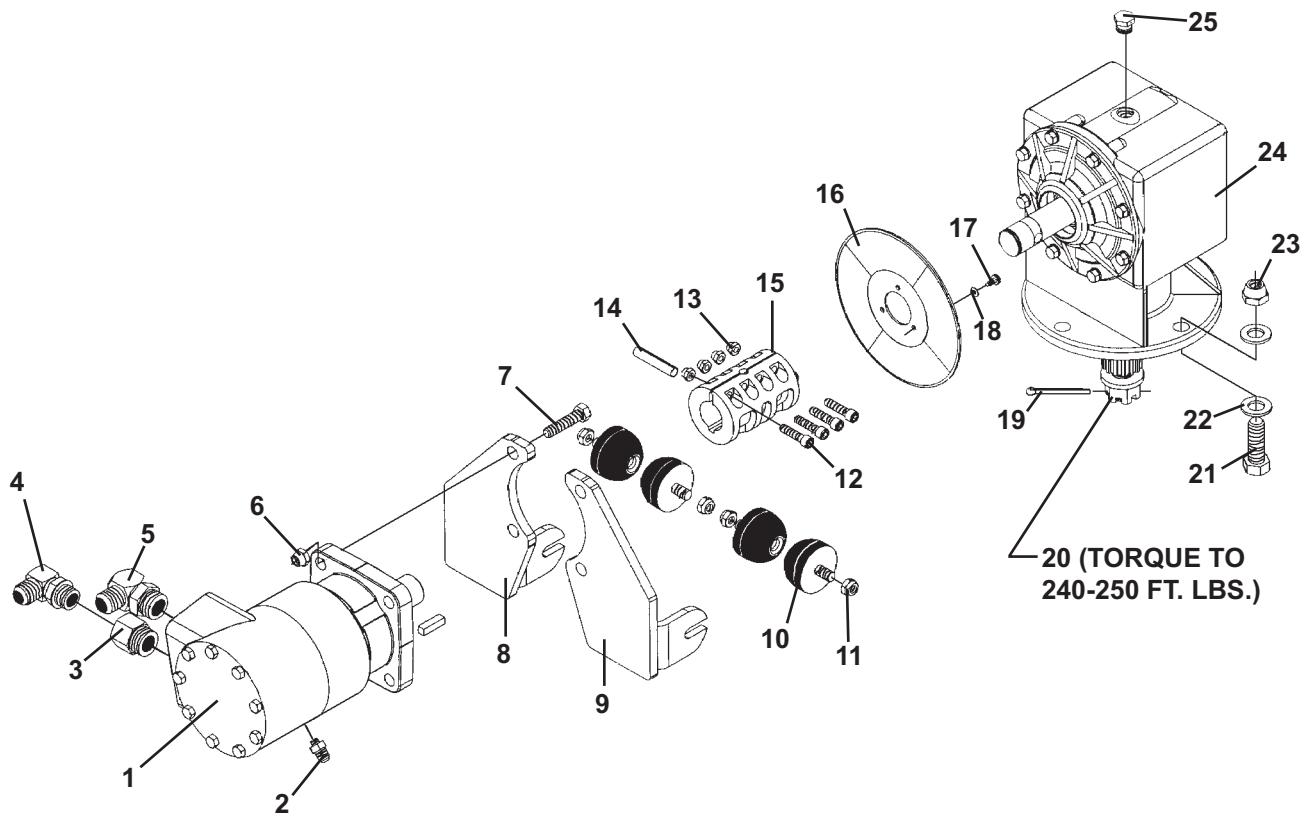

ROTARY CUTTER ASSEMBLY

72 & 78" HIGH FLOW DRIVE ASSEMBLY #104740

<u>NO</u>	<u>REQ'D</u>	<u>PART NO.</u>	<u>DESCRIPTION</u>
1	1	100928	High Flow Hydraulic Motor (17.9 Cu. In.)
	-	5661	Replacement Key
2	1	3269	Straght Connector 8MBo-6MJ
3	1	30292	Straght Adapter 16MBo-12FB
4	1	22600	90° Elbow 12MBo-12MJ
5	1	30051	90° Elbow 16MBo-12MJ
6	4	1839	.62" UNC Deformed Lock Nut
7	4	10071	.62" UNC X 2.25" Hex Capscrew
8	1	104561	Left Motor Mount
9	1	104562	Right Motor Mount
10	4	6886	Bumper
11	4	1841	.50" UNC Deformed Lock Nut
12	4	1799	.38" UNC X 1.50" Socket Head Capscrew
13	4	1837	.38" UNC Deformed Lock Nut
14	1	22277	.50" X 2.50" Roll Pin
15	1	100917	Coupler
16	1	17843	Blade Rotation Indicator
17	3	1001	.25" UNC X .50" Hex Capcrew
18	3	1501	.25" Lock Washer
19	1	1793	Cotter Pin
20	-	19701	Replacement Castle Nut
21	4	1141	.75" UNC X 2.50" Hex Capscrew
22	8	1649	.75" Hard Flat Washer
23	4	1936	.75" UNC Lock Nut
24	1	101509	Right Angle Gearbox Assembly
25	1	7781	Breather Plug

HYDRAULIC ASSEMBLY

HYDRAULIC ASSEMBLIES FOR HIGH FLOW DRIVES

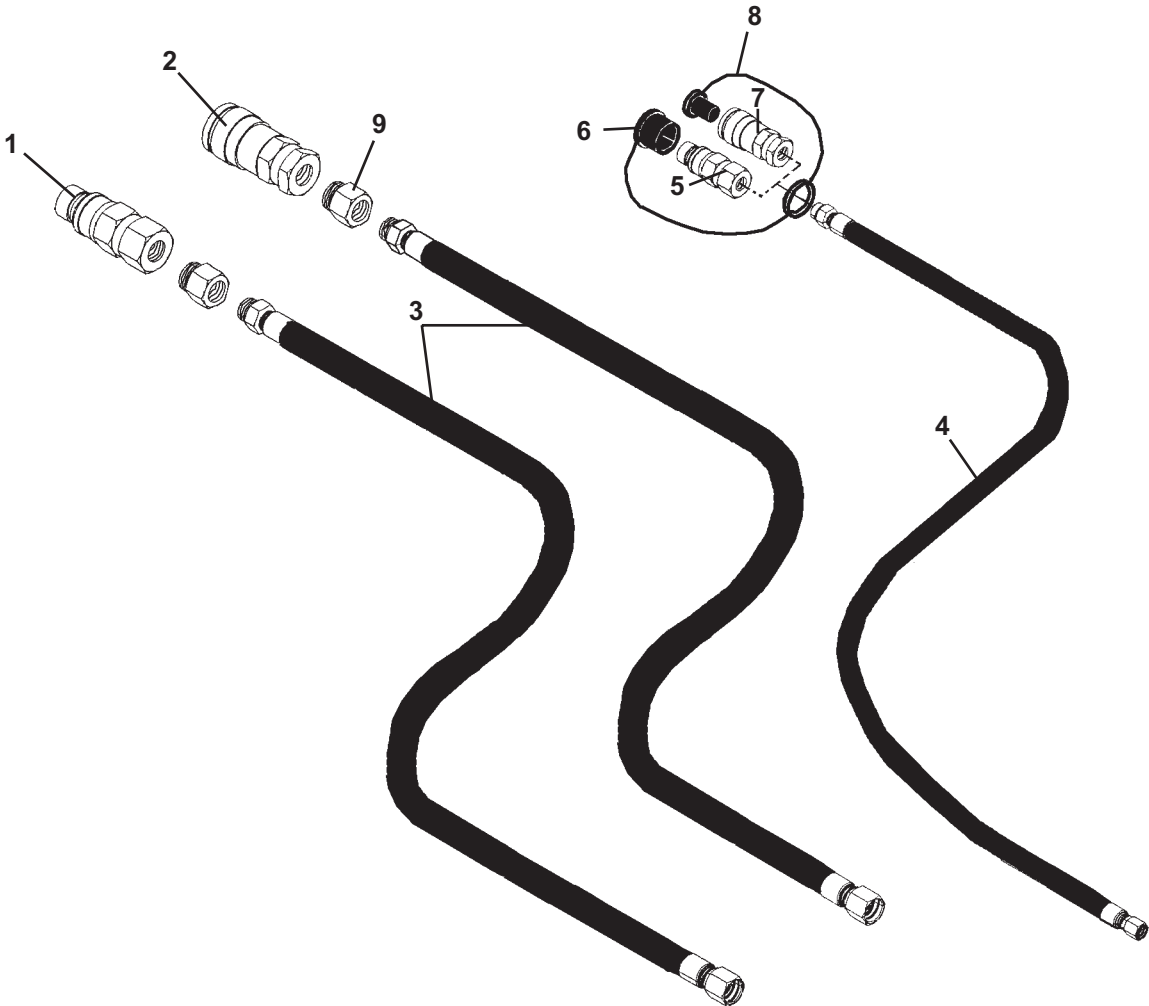

HYDRAULIC ASSEMBLY

HYDRAULIC ASSEMBLIES FOR HIGH FLOW DRIVES

HYDRAULIC KIT #105779

<u>NO</u>	<u>REQ'D</u>	<u>PART NO.</u>	<u>DESCRIPTION</u>
1	1	19638	Male Coupler .75" Body 12FBo
2	1	22520	Female Coupler .75" Body 12FBo
3	2	37060	Hose Assembly .75" X 88" 12MBo-12FJX
4	1	38151	Hose Assembly .38" X 94" 6FJX-8MBo
5	1	84923	Male Coupler .38" Body 8FBo
6	1	32549	Dust Cap

HYDRAULIC KIT #105780

<u>NO</u>	<u>REQ'D</u>	<u>PART NO.</u>	<u>DESCRIPTION</u>
1	1	84922	Male Coupler .62" Body 12FBo
2	1	84921	Female Coupler .62" Body 12FBo
3	2	37769	Hose Assembly .75" X 108" 12MBo-12FJX
4	1	38162	Hose Assembly .38" X 112" 6FJX-8MBo
5	1	84923	Male Coupler .38" Body 8FBo
6	1	32549	Dust Cap

HYDRAULIC KIT #105781

<u>NO</u>	<u>REQ'D</u>	<u>PART NO.</u>	<u>DESCRIPTION</u>
1	1	22519	Male Coupler .50" Body 12FBo
2	1	22518	Female Coupler .50" Body 12FBo
3	2	37060	Hose Assembly .75" X 88" 12MBo-12FJX
4	1	38151	Hose Assembly .38" X 94" 6FJX-8MBo
5	1	84923	Male Coupler .38" Body 8FBo
6	1	32549	Dust Cap

HYDRAULIC KIT #105782

<u>NO</u>	<u>REQ'D</u>	<u>PART NO.</u>	<u>DESCRIPTION</u>
1	1	19638	Male Coupler .75" Body 12FBo
2	1	22520	Female Coupler .75" Body 12FBo
3	2	37060	Hose Assembly .75" X 88" 12MBo-12FJX
4	1	38151	Hose Assembly .38" X 94" 6FJX-8MBo
7	1	84928	Female Coupler .38" Body 8FBo
8	1	32548	Dust Plug

HYDRAULIC KIT #105783

<u>NO</u>	<u>REQ'D</u>	<u>PART NO.</u>	<u>DESCRIPTION</u>
1	1	16434	Male Coupler 1.00" Body 16FBo
2	1	16433	Female Coupler 1.00" Body 16FBo
3	2	37060	Hose Assembly .75" X 88" 12MBo-12FJX
4	1	38151	Hose Assembly .38" X 94" 6FJX-8MBo
5	1	14176	Male Coupler 50" Body 8FBo
6	1	17921	Dust Cap
9	2	30292	Straight Adapter 12FBo-16MBo

MOUNTING KIT INSTALLATION

WHEEL KIT ASSEMBLY #24518

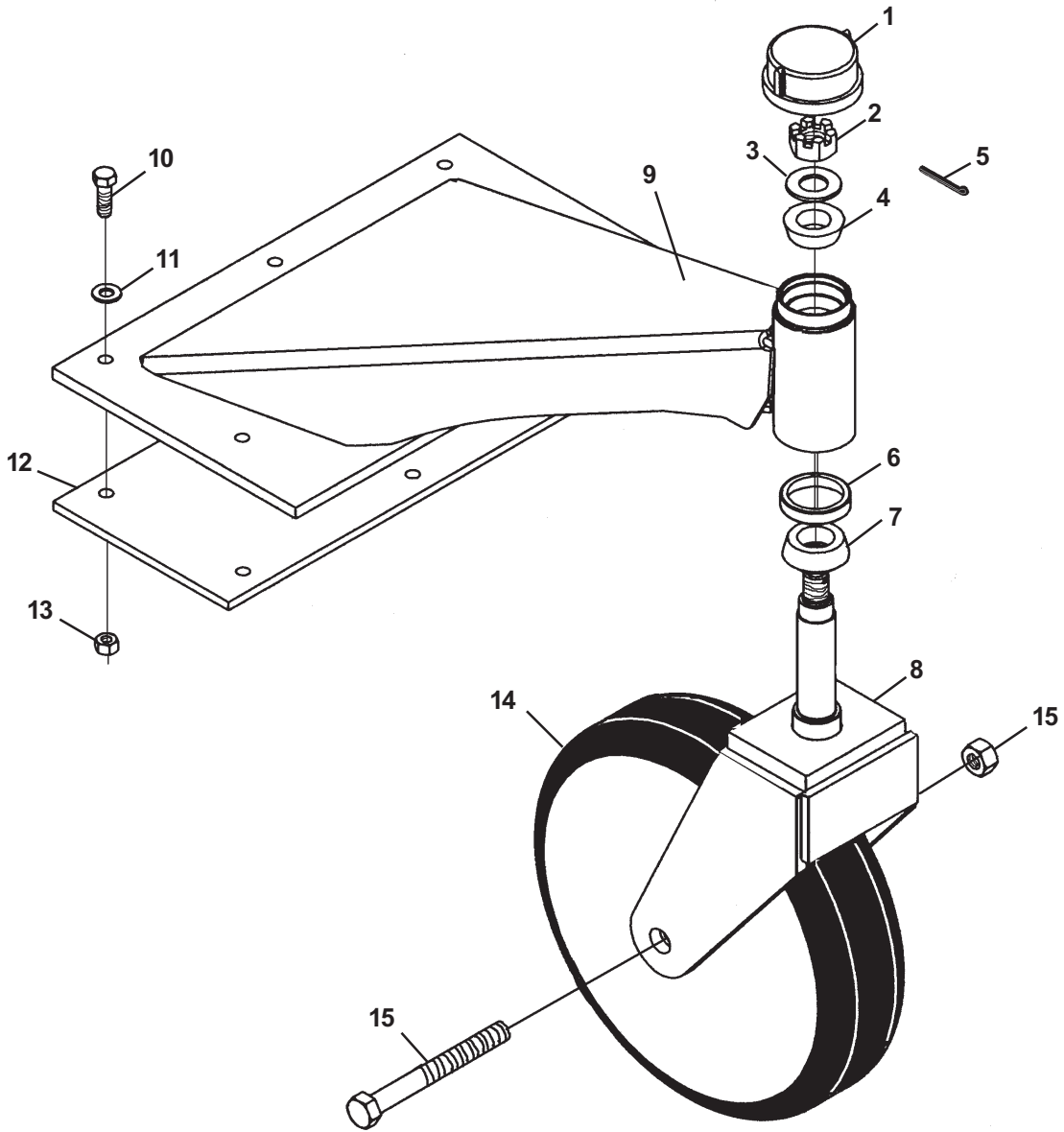

MOUNTING KIT INSTALLATION

WHEEL KIT ASSEMBLY #24518

<u>NO</u>	<u>REQ'D</u>	<u>PART NO.</u>	<u>DESCRIPTION</u>
1	1	101414	Spindle Dust Cap
2	1	10047	1.00" UNC Castle Nut
3	1	1706	1.00" Hard Flat Washer
4	1	33715	Tapered Roller Bearing
5	1	1614	Cotter Pin
6	1	33714	Tapered Roller Bearing
7	1	15511	Seal
8	1	101115	Wheel Yoke
9	1	24513	Support Arm
10	5	1091	.50" UNC x 1.75 Hex Capscrew, Grade 8
11	10	1516	.50" Hard Flat Washer
12	1	24530	.38" x 9.00" x 21.00 Plate
13	5	1841	.50" UNC Locknut, Grade 8
14	1	101195	Foam Filled Wheel & Tire Assembly
	1	6616	Replacement Zerk
15	1	10105	Wheel Shaft/Nut Assembly

INSTALLATION INSTRUCTIONS

GENERAL INFORMATION

The following instructions will help you to mount your rotary cutter onto your skid-steer loader. The rotary cutter uses the quick-attach system for ease of installation. Therefore, if you know how to attach your loader bucket, attaching the rotary cutter should prove no problem.

Remember to read all safety warnings, decals and operating instructions before operating the attachment. If there is any portion of this manual that you do not understand, contact your dealer.

DANGER!  **TO AVOID SERIOUS PERSONAL INJURY OR DEATH THE BRADCO ROTARY CUTTER MUST NOT BE ATTACHED TO ANY POWER UNIT THAT DOES NOT HAVE A SHATTERPROOF DOOR (OR FRONT SHIELD) INSTALLED.**

WARNING!  **OPERATING THE STANDARD FLOW ROTARY CUTTER ON A HIGH FLOW HYDRAULIC SYSTEM MAY CAUSE SEVERE INJURY OR DEATH TO THE OPERATOR OR BYSTANDERS DUE TO THE INCREASED RPM. DO NOT OPERATE THE STANDARD FLOW ROTARY CUTTERS ON HIGH FLOW HYDRAULIC SYSTEMS.**

INSTALLATION INSTRUCTIONS

NOTE: Before attaching the rotary cutter to your skid-steer loader, make sure a shatter-proof door (or front shield) has been installed onto the front of your skid-steer loader. This is required to protect the operator from possible thrown objects.

1. Remove the shipping banding from around the rotary cutter and skid.
2. Remove any attachments from the front of the loader.
3. Following all standard safety practices and the instructions for installing an attachment in your skid-steer operator's manual, install the rotary cutter onto your skid-steer.

NOTE: It is important to make sure the locking mechanism on your quick attach is engaged, therefore locking the attachment onto the skid-steer.

4. Connect the Lift Limiting Chain to your skid-steer. The back of the rotary cutter should never be more than 1 foot off the ground for proper and safe cutting. (Raise the unit to 1 foot above ground level. Route the end of the Lift Limiting Chain through the "D" ring on the back of the rotary cutter and then through the tie down mechanism(s) on the front of your skid-steer loader. Tie the chain securely back to itself with the shackle provided, to limit the lifting capabilities of the cutter to 1 foot maximum.)
5. Lower the unit to the ground and remove the key.
6. After making sure that there is not any foreign matter on the hydraulic couplers, connect the couplers to the auxiliary hydraulic system of your skid-steer loader.

IMPORTANT: Do not operate the BRADCO standard flow rotary cutter on High Flow Hydraulic systems. Doing so will void the standard flow rotary cutter warranty.

OPERATING INSTRUCTIONS

ROTARY CUTTER

GENERAL INFORMATION

The BRADCO rotary cutter is perfect for cutting tall grass and brush up to 4" in diameter.

The rotary cutter attaches to the toolbar/quick-attach mechanism of your skid-steer loader. Due to this arrangement, thorough knowledge of the skid-steer controls is necessary for machine operation. Read and understand your skid-steer operator's manual for information regarding skid-steer operation before attempting to use the rotary cutter.

Follow all installation instructions in Section F for the proper installation of the unit onto your skid-steer before attempting to operate your rotary cutter.

OPERATING TIPS

- Increase the life of your bi-directional blades by cutting brush in one direction and cutting grass and smaller vegetation in the other. (This will keep the blades sharp for cutting grass.)
- If your preferred direction of blade rotation is not set up correctly for your skid-steers "detent", the hydraulic hoses may be reversed at the motor end.
- Continuous rotation of the blades is required during operation to prevent overheating of the hydraulic system. The rotary cutter is equipped with a blade rotation indicator disk to assist in monitoring blade rotation. If the rotary cutter stalls, disengage auxiliary hydraulics, and remove cutter from debris before restarting.
- Engage and disengage the hydraulic system with the skid-steer at idle.

WARNING! Before leaving the operator's seat: Lower the lift arms against frame and place unit on the ground. Disengage auxiliary hydraulics. Stop Engine. Engage parking brake. Remove the key.



DANGER! ROTATING BLADE HAZARD! STAY BACK!
OBJECTS CAN BE THROWN!



DO NOT operate near bystanders.
DO NOT place hands or feet under deck while in operation or with engine running.
DO NOT operate without a shatterproof door (or front shield) installed on loader.

WARNING! Operating the standard flow rotary cutter on a high flow hydraulic system may cause severe injury or death to the operator or bystanders due to the increased RPM. Do NOT operate the standard flow rotary cutters on high flow hydraulic systems.



WARNING! Lift limiting chain must be properly installed before operation.



OPERATING INSTRUCTIONS

ROTARY CUTTER

CUTTING OPERATION

1. Raise the back of the unit off of the ground approximately 4" to allow the material to clear from under the cutting deck as you travel forward.
2. Place the front skid shoes 1-2 inches off the ground. This is the preferred position for cutting grass and heavy vegetation.
 - Never drive your skid-steer with the front of the rotary cutter tilted to the point your view is obstructed. Always make sure you can see what you are cutting.
 - Check the work area. Never operate the rotary cutter in populated areas where thrown objects could injure persons or damage property.
 - Never raise the unit and expose yourself or anyone else to the rotating blades. If you can see the blades then the back of the unit is raised too high.
3. Activate the auxiliary hydraulics with the engine at idle. Increase engine speed.
4. Be sure the rotary cutter is operating smoothly and at full speed, and then start forward travel while monitoring blade rotation.

NOTE: The rotary cutter has a window in the motor cover shield so the operator can see the blade rotation indicator disk. This disk should always be rotating during operation to prevent a drop in hydraulic pressure or overheating of the hydraulic system.

CUTTING LARGE BRUSH UP TO 3-4" IN DIAMETER:

When cutting large brush, roll the front of the rotary cutter up 1-2 feet. **DO NOT LIFT THE BACK OF THE CUTTER!** Slowly drive into the tree and use the hydraulic tilt function on the skid-steer to bend or push the tree over. As the tree bends, the blades will cut it off. The tree can now be mulched by rotating the front up, drive forward several feet, roll the front down onto the tree and backdrag. Repeat, if necessary. Remember do not lift the back of the cutter.

AVOID STALLING ROTARY CUTTER: Continuous rotation is required to prevent overheating of the hydraulic system. The rotary cutter is equipped with a blade rotation indicator disk to assist in monitoring blade rotation. If the rotary cutter stalls, see "TO RESTART BLADE ROTATION".

TO RESTART BLADE ROTATION: Return engine speed to idle and disengage auxiliary hydraulics. Remove rotary cutter from debris. Engage auxiliary hydraulics to start blade rotation. (Be sure the rotary cutter is operating smoothly and at full speed, and then start forward travel while monitoring blade rotation.)

OPERATING INSTRUCTIONS

ROTARY CUTTER

REPEATED STALLING OF ROTATING BLADES: Return engine speed to idle and disengage auxiliary hydraulics. Remove rotary cutter from debris. Review operating conditions and the size/density of material being cut. Make necessary corrections. Engage auxiliary hydraulics to start blade rotation. (Be sure the rotary cutter is operating smoothly and at full speed, and then start forward travel while monitoring blade rotation.)

TROUBLESHOOTING OPERATING CONDITIONS:

Below are listed a few operating conditions that may cause repeated stalling of your rotary cutter, and suggestions on how to correct them.

GRASS TOO LONG OR THICK: If cutting heavy vegetation, you may need to slow travel speed or make smaller passes (less than full cut) to prevent overloading and stalling the unit.

BRUSH TOO BIG IN DIAMETER: The rotary cutter is NOT designed to cut trees larger than 3-4" in diameter. If brush is smaller than 3-4" in diameter and the cutter is stalling, check sharpness of the blades (see "Maintenance" Section L) and cut using the procedure described earlier in this section for "Cutting Large Brush".

BRUSH TOO THICK OR HEAVY: If cutting heavy or thick brush, you may need to slow travel speed or make smaller passes (less than full cut), to prevent overloading. If the blades seem to be unable to handle the volume of brush, slow down the travel speed until the unit reaches full speed before proceeding.

SCALPING THE GROUND or BOTTOMING OUT: Be aware of changes in the terrain. Stay alert for drop-off and holes. Check the terrain and the deck position before restarting and continuing cutting.

STRIKING FOREIGN OBJECTS: Stay alert for rocks, fencing, abandoned wells, septic tanks or other foreign objects. If the rotary cutter comes into contact with a foreign object, stop the unit, shut off the engine and disconnect the hydraulic couplers from the skid-steer. Inspect the unit and repair any damage before restarting and continuing cutting. (Never try to weld or straighten damaged blades.) Inspect the work area for any other items, and if they are too large to be removed from the area, they should be flagged clearly.

LUBRICATION

GENERAL INFORMATION

Economical and efficient operation of any machine is dependent upon regular and proper lubrication of all moving parts with a quality lubricant. Neglect leads to reduced efficiency, wear, breakdown, and needless replacement of parts.

WEEKLY

The oil level in the gear box should be checked once a week. Fill as necessary with 80-90 weight gear lubricant.

TO CHECK:

Remove pipe plug from end of gearbox. Lubricant should be at the same level as the plug.

TO ADD:

Remove pipe plug from end of gearbox. Remove filler plug from top end of gearbox and add 80-90 weight gear lubricant up to the same level as the pipe plug. Replace pipe plug and filler plug.

IMPORTANT: DO NOT OVERFILL, AS TOO MUCH LUBRICANT MAY RUPTURE THE GEAR BOX SEALS.

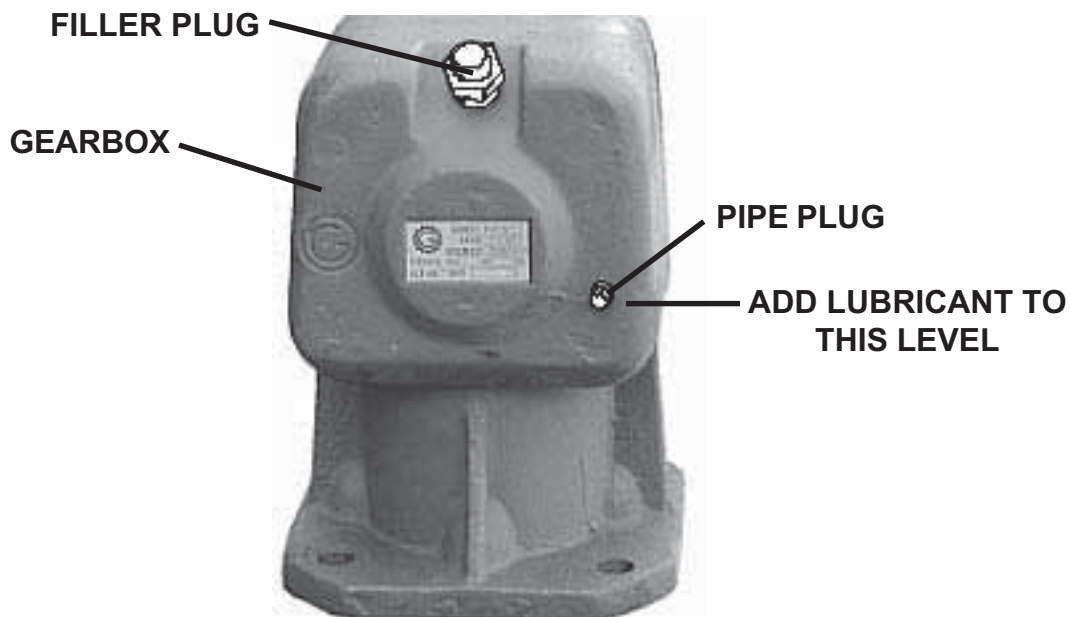

MAINTENANCE

ROTARY CUTTERS

GENERAL INFORMATION

Regular maintenance is the key to long equipment life and safe operation. Maintenance requirements have been reduced to an absolute minimum. However, it is very important that these maintenance functions be performed as described below.

WARNING! Avoid serious injury. Lower the rotary cutter to the ground, set the parking brake, stop the skid-steer engine, and remove the key before leaving the operator's seat. If unit must be left raised for maintenance, block the unit securely to prevent accidental release of the lifting mechanism. Disconnect the hydraulic couplers.



DAILY

- Check skid-steer loader hydraulic system to ensure an adequate level of hydraulic oil.
- Check gearbox castle nut and torque to min. 250 - max 350 ft. lbs.
- Check mounting hardware on blades and torque to 450 ft. lbs.
- Check all other hardware and tighten, if necessary. See Section O.
- Check hydraulic system for hydraulic oil leaks.
- Check gearbox power shaft for foreign material wrapped around the shaft and remove, if necessary.
- Check blades for damage and replace or sharpen as needed.
- Check all safety guards and ensure that all devices are installed correctly.
- Check for missing or illegible Safety / Warning Decals.

WARNING! Escaping fluid under pressure can have sufficient force to penetrate the skin, causing serious personal injury. Fluid escaping from a very small hole can be almost invisible. Use a piece of cardboard or wood, rather than hands to search for suspected leaks.



Keep unprotected body parts, such as face, eyes, and arms as far away as possible from a suspected leak. Flesh injected with hydraulic fluid may develop gangrene or other permanent disabilities.

If injured by injected fluid, see a doctor at once. If your doctor is not familiar with this type of injury, ask him to research it immediately to determine proper treatment.

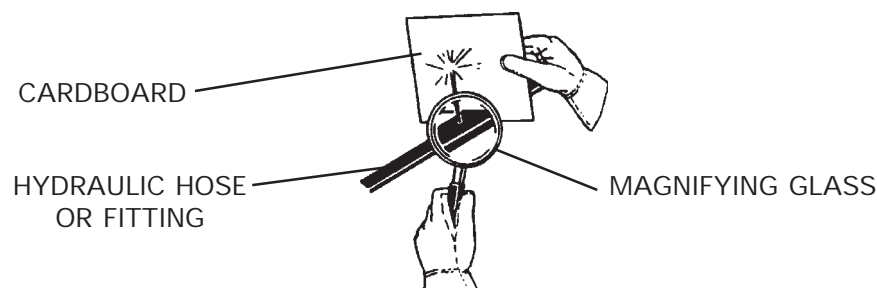

EVERY 40 HOURS

- Check oil level in gearbox and add if necessary. (See Section H)

MAINTENANCE

ROTARY CUTTERS

WARNING! Avoid serious injury. Lower the rotary cutter to the ground, set the parking brake, stop the skid-steer engine, and remove the key before leaving the operator's seat. If unit must be left raised for maintenance, block the unit securely to prevent accidental release of the lifting mechanism. Disconnect the hydraulic couplers.



REPLACING BLADES

When replacing, changing, or sharpening the blades, the unit must be blocked securely off the ground to gain access to the blades.

The blades should be inspected regularly (every 8 hours) to ensure they are sharp, tightened correctly, and intact. Always replace both blades at the same time and NEVER try to weld or straighten damaged blades, as loss of blade integrity may result.

Removing Blades:

1. With unit securely blocked off the ground and hydraulic couplers disconnected, loosen the capscrews on the blade access cover and swing cover open.
2. Position one of the blades under the access panel and remove the cotter pin and special nut. You can now remove the blade mounting bolt and the blade.
3. Repeat step #2 for the remaining blade.

Installing Blades:

1. With unit securely blocked off the ground and hydraulic couplers disconnected, loosen the capscrews on the blade access cover and swing cover open.
2. Position the blade with the key of the mounting bolt in alignment with the key way, and either prop up in place or have an assistant hold in place while the special nut is installed onto the bolt through the blade access panel. Torque nut to 450 ft. lbs. and install cotter pin.
3. Repeat step #1 for the second blade.

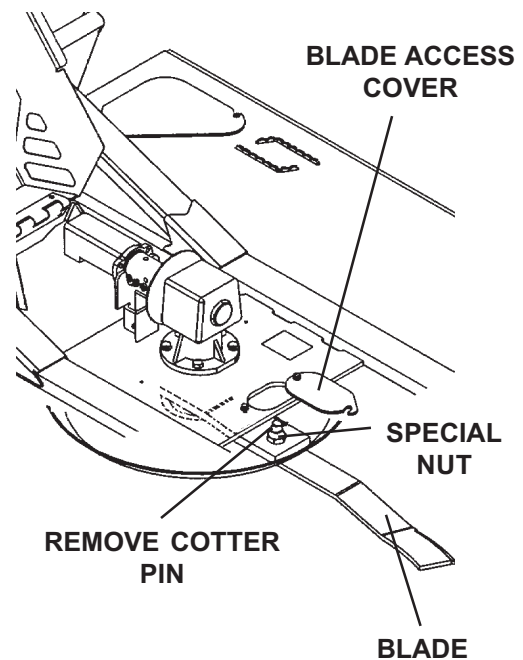

MAINTENANCE

ROTARY CUTTERS

WARNING! Avoid serious injury. Lower the rotary cutter to the ground, set the parking brake, stop the skid-steer engine, and remove the key before leaving the operator's seat. If unit must be left raised for maintenance, block the unit securely to prevent accidental release of the lifting mechanism. Disconnect the hydraulic couplers.



REPLACING HYDRAULIC MOTOR

When replacing the hydraulic motor the unit should be setting on the ground with the hydraulic couplers disconnected.

NOTE: Field replacement of the internal motor seals voids warranty.

1. With unit setting on the ground and hydraulic couplers disconnected, tag and disconnect the hydraulic hoses and fittings from the hydraulic motor. Note the hose routing for re-installation.
2. Loosen the four sockethead capscrews on the coupler and slide the motor out of the coupler.
3. Remove the capscrews holding the motor to the motor mounting plate(s), and remove the motor.
4. Install the new motor onto the mounting plate(s) using the existing hardware.
5. Slide the motor with the mounting plate(s) into the coupler and retighten the sockethead capscrews. Torque all hardware to specification. See Section O.
6. Re-connect the hydraulic hoses and fittings to the new motor.

**STANDARD FLOW
CUTTER SHOWN**

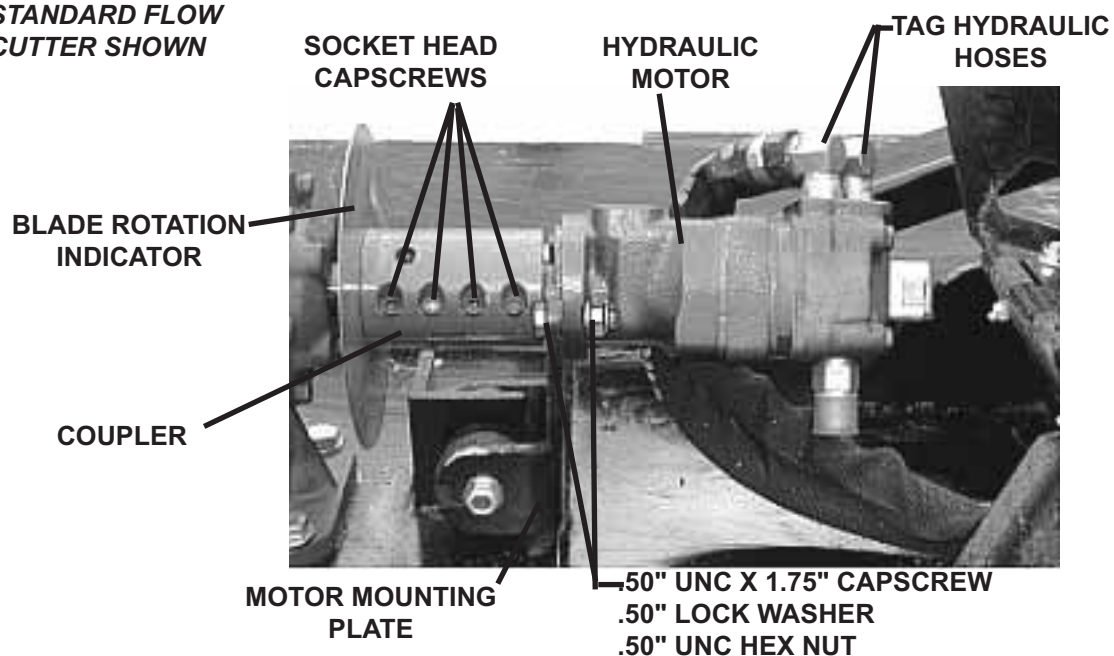

MAINTENANCE

ROTARY CUTTERS

WARNING! Avoid serious injury. Lower the rotary cutter to the ground, set the parking brake, stop the skid-steer engine and remove the key before leaving the operator's seat. If unit must be left raised for maintenance, block the unit securely to prevent accidental release of the lifting mechanism. Disconnect the hydraulic couplers.



REPLACING GEARBOX/MOTOR COUPLER

When replacing the coupler the unit should be setting on the ground with the hydraulic couplers disconnected.

1. With unit setting on the ground and hydraulic couplers disconnected, loosen the four sockethead capscrews on the coupler and remove the motor with the motor mounting plate still installed.
2. Remove the roll pin holding the coupler to the gearbox, and the three capscrews holding the blade rotation indicator to coupler.
3. Replace the coupler on the gearbox shaft, and reinstall the roll pin and the blade rotation indicator using the existing hardware.
4. Reinstall the motor into the coupler, and retighten the sockethead capscrews. Torque to specification. See Section O.

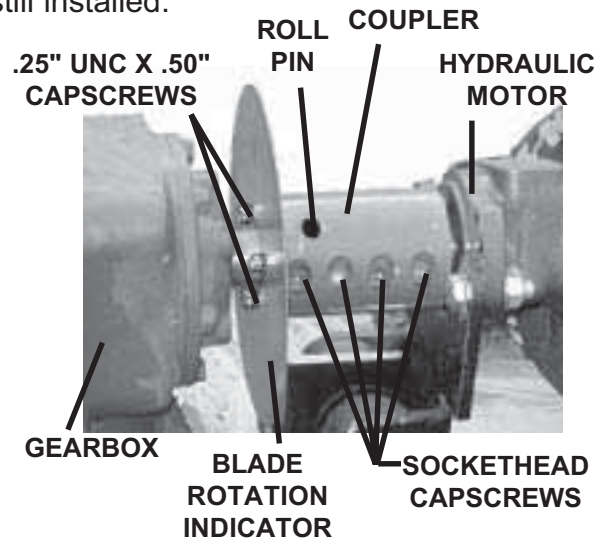

WARNING! Avoid serious injury. Lower the rotary cutter to the ground, set the parking brake, stop the skid-steer engine, and remove the key before leaving the operator's seat. If unit must be left raised for maintenance, block the unit securely to prevent accidental release of the lifting mechanism. Disconnect the hydraulic couplers.



REPLACING GEARBOX

When replacing the gearbox, the unit must be blocked securely off the ground to gain access to the castle nut holding the stump jumper to the lower end of the gearbox.

1. With unit securely blocked off the ground and hydraulic couplers disconnected, remove the cotter pin and castle nut holding the stump jumper to the lower end of the gearbox. **NOTE: Be prepared for the weight of the stump jumper with the blades attached to fall when the castle nut is removed.**

MAINTENANCE

ROTARY CUTTERS

2. Remove the roll pin holding the coupler to the gearbox and the three cap-screws holding the blade rotation indicator to coupler.
3. Loosen the four socket head capscrews on the coupler and slide the coupler along with the motor assembly off of the gearbox drive shaft.
4. Remove the four capscrews securing the gearbox to the rotary cutter deck, and lift the gearbox off the cutter.
5. Install the new gearbox with the existing hardware removed in Step #4.
6. Position the stump jumper onto the lower end of the gearbox and reinstall the castle nut. Torque nut to 230 ft. lbs. Continue to tighten until the next nut castellation aligns with cross pin hole in the output shaft. Final torque range must be between 240 - 250 lt. lbs. Reinstall cotter pin.
7. Install the blade rotation indicator onto the gearbox followed by the coupler/motor assembly.
8. Reinstall the .25" capscrews securing the blade rotation indicator to the coupler, reinstall the roll pin, and tighten the four sockethead capscrews specification. See Section O.
9. Check lubrication level in the gearbox and add as needed. See Section H.

STANDARD FLOW CUTTER SHOWN

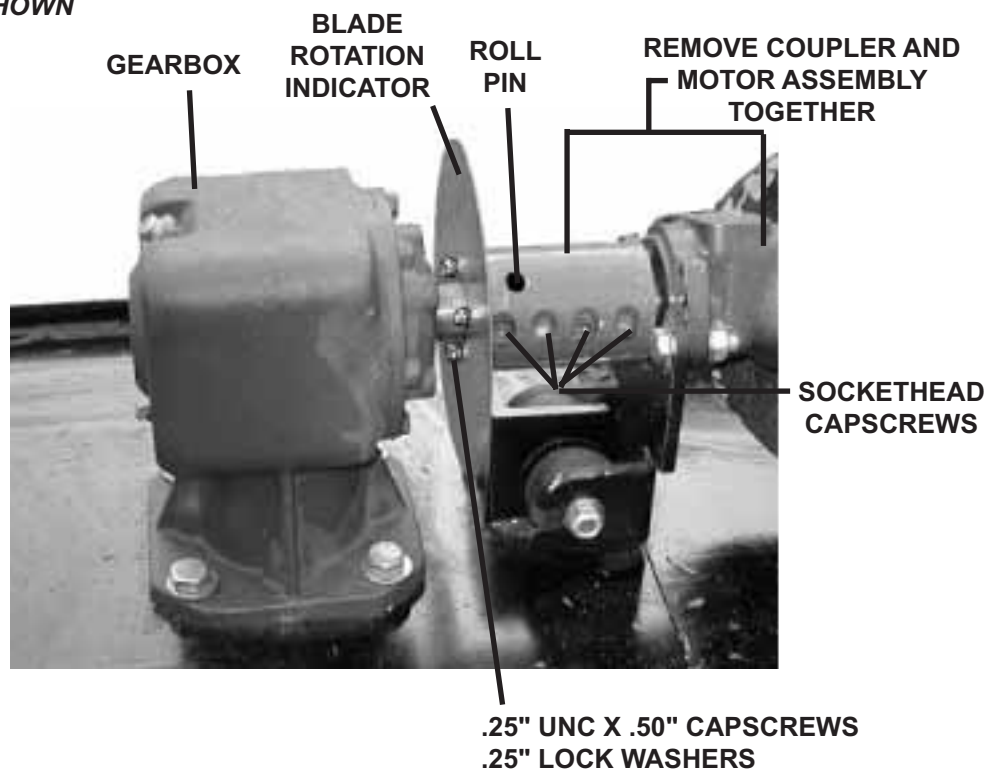

STORAGE

ROTARY CUTTER

GENERAL INFORMATION

The following storage procedure will help you to keep your rotary cutter in top condition. It will also help you get off to a good start the next time your cutter is needed. We therefore strongly recommend that you take the extra time to follow these procedures whenever your unit will not be used for an extended period of time.

PREPARATION FOR STORAGE

1. Clean the unit thoroughly, removing all mud, dirt, and grease.
2. Sharpen or replace blades. Replace all blades at the same time and do not try to weld or straighten damaged blades; loss of integrity may result.
3. Inspect for visible signs of wear, breakage, or damage. Order any parts required, and make the necessary repairs to avoid delays when starting next season. **NOTE: Purchase only approved replacement parts from your authorized BRADCO dealer.**
4. Tighten all loose nuts, capscrews, and hydraulic connections.
5. Check the gear box for proper lubricant level.
6. Connect the hydraulic couplers together to protect the hydraulic system from contaminants.
7. Touch up all unpainted and exposed areas with paint, to prevent rust.
8. Replace decals if damaged, or in unreadable condition.
9. Apply a rust-preventive spray to all moving parts and to the bottom of the deck.
10. Store the unit in a dry and protected place. Leaving the unit outside will materially shorten its life.

REMOVING FROM STORAGE

1. Remove all protective coverings.
2. Check hydraulic hoses for deterioration, and replace if necessary.
3. Check all nuts and bolts for proper tightness, especially those securing the motor, gearbox and blades.

TROUBLESHOOTING

ROTARY CUTTER

PROBLEM	POSSIBLE CAUSE	POSSIBLE REMEDY
Loss of Power.	Skid-steer auxiliary valve not engaged.	Engage auxiliary valve.
	Relief valve setting adjusted too low.	Refer to skid-steer operator's manual.
	Inadequate hydraulic flow from skid-steer.	Check hydraulic flow to rotary cutter.
	Low oil supply.	Add oil.
	Couplers not engaged.	Engage couplers.
	Air in hydraulic lines.	Activate system until air is purged from system.
	Broken hose.	Replace damaged hose.
	Obstruction in hydraulic lines.	Remove obstruction and replace if necessary.
	Loose or damaged hydraulic connection.	Tighten or replace fittings.
Broken gearbox pin.	Replace pin.	
Hydraulic motor damaged or seal blown.	Call Bradco service department for instructions.	

PROBLEM	POSSIBLE CAUSE	POSSIBLE REMEDY
Excessive vibration.	Dull, broken or damaged blades.	Sharpen or replace.
	Bent gearbox shaft.	Call Bradco service department for instructions.
	Stump Jumper out of balance.	Call Bradco service department for instructions.

PROBLEM	POSSIBLE CAUSE	POSSIBLE REMEDY
Leaking oil.	Loose or damaged hydraulic line.	Tighten or replace.
	Ruptured gearbox seal.	Call Bradco service department for instructions.
	Bent gearbox shaft.	Call Bradco service department for instructions.
	Loose or missing gearbox plug.	Tighten or replace.
	Hydraulic motor damaged or seal blown.	Call Bradco service department for instructions.



BOLT TORQUE

BOLT TORQUE SPECIFICATIONS

GENERAL TORQUE SPECIFICATION TABLE

Use the following torques when special torques are not given. These values apply to fasteners as received from suppliers, dry, or when lubricated with normal engine oil. They do not apply if special graphited or moly disulphide greases or other extreme pressure lubricants are used. This applies to both UNF and UNC threads. Remember to always use grade five or better when replacing bolts.

SAE Grade No.		2				5				8*			
Bolt head identification marks as per grade. NOTE: Manufacturing Marks Will Vary													
		TORQUE		TORQUE		TORQUE		TORQUE		TORQUE		TORQUE	
Bolt Size		Pounds Feet		Newton-Meters		Pounds Feet		Newton-Meters		Pounds Feet		Newton-Meters	
Inches	Millimeters	Min.	Max.	Min.	Max.	Min.	Max.	Min.	Max.	Min.	Max.	Min.	Max.
1/4	6.35	5	6	6.8	8.13	9	11	12.2	14.9	12	15	16.3	30.3
5/16	7.94	10	12	13.6	16.3	17	20.5	23.1	27.8	24	29	32.5	39.3
3/8	9.53	20	23	27.1	31.2	35	42	47.5	57.0	45	54	61.0	73.2
7/16	11.11	30	25	40.7	47.4	54	64	73.2	86.8	70	84	94.9	113.9
1/2	12.70	45	52	61.0	70.5	80	96	108.5	130.2	110	132	149.2	179.0
9/16	14.29	65	75	88.1	101.6	110	132	149.2	179.0	160	192	217.0	260.4
5/8	15.88	95	105	128.7	142.3	150	180	203.4	244.1	220	264	298.3	358.0
3/4	19.05	150	185	203.3	250.7	270	324	366.1	439.3	380	456	515.3	618.3
7/8	22.23	160	200	216.8	271.0	400	480	542.4	650.9	600	720	813.6	976.3
1	25.40	250	300	338.8	406.5	580	696	786.5	943.8	900	1080	1220.4	1464.5
1-1/8	25.58	-	-	-	-	800	880	1084.8	1193.3	1280	1440	1735.7	1952.6
1-1/4	31.75	-	-	-	-	1120	1240	1518.7	1681.4	1820	2000	2467.9	2712.0
1-3/8	34.93	-	-	-	-	1460	1680	1979.8	2278.1	2380	2720	3227.3	3688.3
1-1/2	38.10	-	-	-	-	1940	2200	2630.6	2983.2	3160	3560	4285.0	4827.4

* Thick Nuts must be used with Grade 8 bolts

METRIC BOLT TORQUE SPECIFICATIONS

Size of Screw	Grade No.	Coarse Thread			Fine Thread		
		Ptich (mm)	Pounds Feet	Newton-Meters	Pitch (mm)	Pounds Feet	Newton-Meters
M6	5.6	1.0	3.6-5.8	4.9-7.9	-	-	-
	8.8		5.8-9.4	7.9-12.7		-	-
	10.9		7.2-10	9.8-13.6		-	-
M8	5.6	1.25	7.2-14	9.8-19	1.0	12-17	16.3-23
	8.8		17-22	23-29.8		19-27	25.7-36.6
	10.9		20-26	27.1-35.2		22-31	29.8-42
M10	5.6	1.5	20-25	27.1-33.9	1.25	20-29	27.1-39.3
	8.8		34-40	46.1-54.2		35-47	47.4-63.7
	10.9		38-46	51.5-62.3		40-52	54.2-70.5
M12	5.6	1.75	28-34	37.9-46.1	1.25	31-41	42-55.6
	8.8		51-59	69.1-79.9		56-68	75.9-92.1
	10.9		57-66	77.2-89.4		62-75	84-101.6
M14	5.6	2.0	49-56	66.4-75.9	1.5	52-64	70.5-86.7
	8.8		81-93	109.8-126		90-106	122-143.6
	10.9		96-109	130.1-147.7		107-124	145-168
M16	5.6	2.0	67-77	90.8-104.3	1.5	69-83	93.5-112.5
	8.8		116-130	157.2-176.2		120-138	162.6-187
	10.9		129-145	174.8-196.5		140-158	189.7-214.1
M18	5.6	2.0	88-100	119.2-136	1.5	100-117	136-158.5
	8.8		150-168	203.3-227.6		177-199	239.8-269.6
	10.9		175-194	237.1-262.9		202-231	273.7-313
M20	5.6	2.5	108-130	146.3-176.2	1.5	132-150	178.9-203.3
	8.8		186-205	252-277.8		206-242	279.1-327.9
	10.9		213-249	288.6-337.4		246-289	333.3-391.6

SPECIFICATIONS

ROTARY CUTTERS

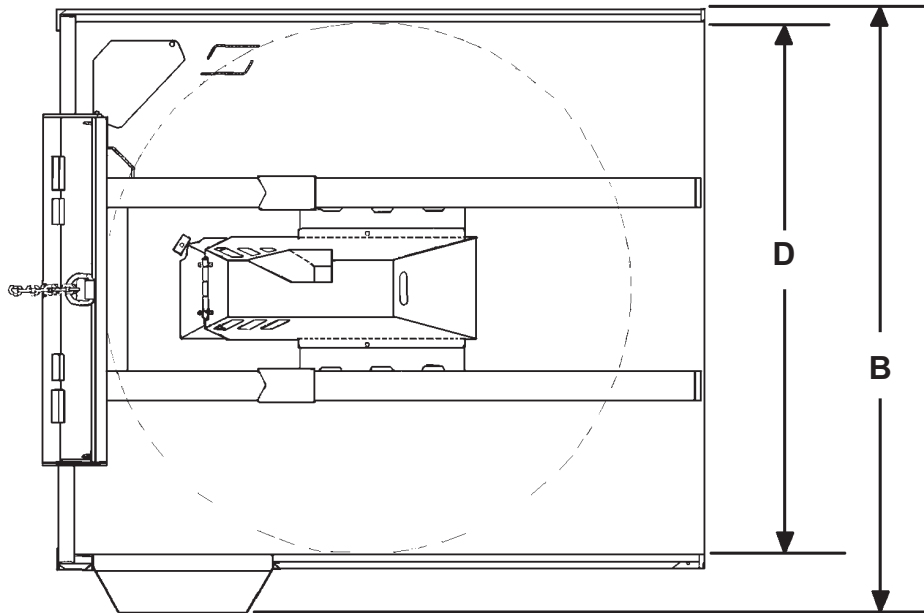
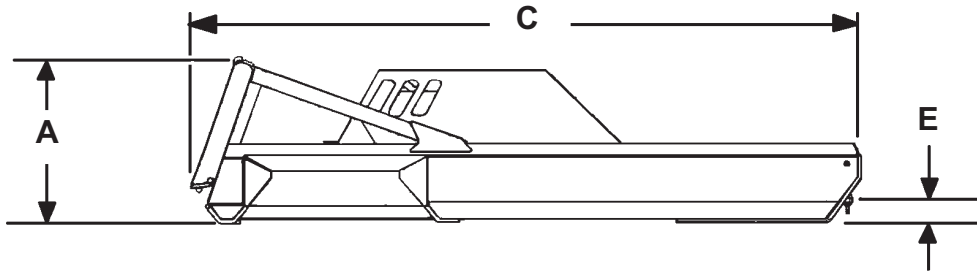

SPECIFICATIONS AND DESIGN ARE SUBJECT TO CHANGE WITHOUT NOTICE AND WITHOUT LIABILITY THEREFOR.

SPECIFICATIONS

DESCRIPTION	STANDARD			HIGH FLOW	
	BC60	BC72	BC60*	BC72	BC78
A. Overall Height.....	22.50"	22.50"	22.50"	22.50"	22.50"
B. Overall Width.....	72.00"	85.00"	72.00"	85.00"	91.00"
C. Overall Length	78.25"	90.25"	78.25"	90.25"	96.00"
D. Cutting Width.....	60.00"	72.00"	60.00"	72.00"	78.00"
E. Minimum Cutting Height 2.00".....	2.00"	2.00"	2.00"	2.00"	2.00"
(Skid Shoes on Ground)					
Cutting Capacity (Max. Cutting Diameter)	4.00"	4.00"	4.00"	4.00"	4.00"
Deck Thickness	1/4" Steel	1/4" Steel	1/4" Steel	1/4" Steel	1/4" Steel
Recommended GPM.....	15-20	18-22	25-30	32-40	32-40
Required Skid-Steer Lift Capacity	1300#	1700#	1300#	1700#	1800#
Weight	1230#	1610#	1230#	1610#	1666#
* (SPECIFICATIONS FOR BC60 WITH SPECIAL MOTOR #106601 ONLY)					

DECALS

DECAL PLACEMENT

GENERAL INFORMATION

The diagrams on this page show the location of the decals used on the BRADCO Rotary Cutter. The decals are identified by their part numbers, with reductions of the actual decals located on the following pages. Use this information to order replacements for lost or damaged decals. Be sure to read all decals before operating the unit. They contain information you need to know for both safety and longevity.

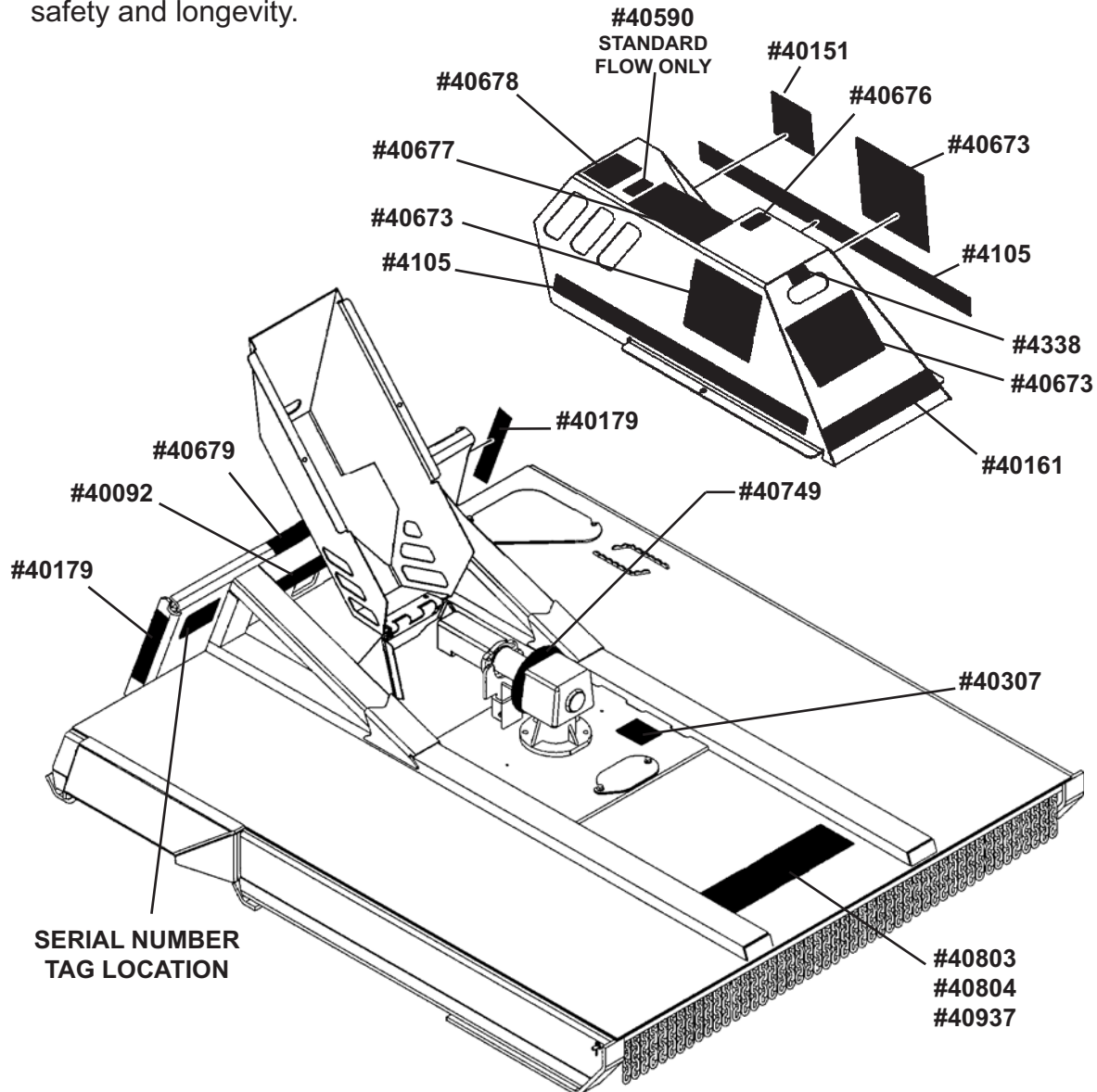

IMPORTANT: Keep all safety signs clean and legible. Replace all missing, illegible, or damaged safety signs. When replacing parts with safety signs attached, the safety signs must also be replaced unless otherwise noted.

REPLACING SAFETY SIGNS: Clean the area of application with nonflammable solvent, then wash the same area with soap and water. Allow the surface to fully dry. Remove the backing from the safety sign, exposing the adhesive surface. Apply the safety sign to the position shown in the diagram above, and smooth out any bubbles.



DANGER! ROTATING BLADE
PART #40673



WARNING! HIGH PRESSURE FLUID
PART #40151



DANGER! GUARD MISSING
PART #40307

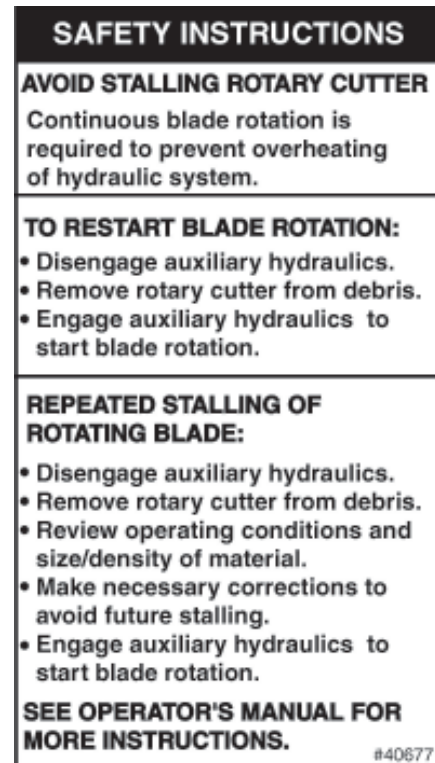

SAFETY INSTRUCTIONS
PART #40677



WARNING! BEFORE LEAVING OPERATOR'S SEAT
PART #40678



WARNING! LIFT LIMITING CHAIN
PART #40679

DECALS



DANGER STAND CLEAR
PART #4105



STAND CLEAR
PART #40161



BLADE ROTATION INDICATOR
PART #40676



CAUTION! DO NOT OPERATE
PART #40590

BC60

BC72 MODEL NUMBER
PART #40803

BC72

BC60 MODEL NUMBER
PART #40804

BC78

BC78 MODEL NUMBER
PART #40937



MADE IN USA
PART #4338

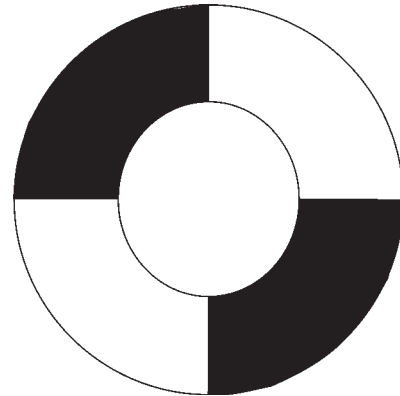

ROTATION INDICATOR
PART #40749

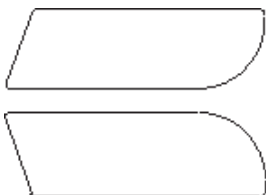

BRADCO LOGO
PART #40092



BRADCO LOGO (VERTICAL)
PART #40179

PREDELIVERY CHECKLIST

GENERAL INFORMATION

The following is a list of areas that should be inspected by the dealer prior to delivery of the Rotary Cutter to the customer. The customer should check the list and make sure that the dealer has completed the inspection. Completion of this checklist will help insure that the customer receives the rotary cutter in complete working order, ready to install.

PREDELIVERY CHECKLIST - CHECK AND ADJUST AS NECESSARY

1. _____ Visually inspect the unit for bent, loose, cracked, damaged or missing parts. Check for any other irregularities.
2. _____ Check and lubricate, if necessary. See "Lubrication" Section H.
3. _____ Check bolts for tightness. Retighten after the first four working hours, and after every eight working hour intervals thereafter. See "Bolt Torque", Section O.
4. _____ Check all hydraulic connections for leaks and all hoses for proper positioning to reduce pinching, chafing and binding.
5. _____ Make sure decals are not damaged or missing and are in their correct location. See "Decals" Section Q.
6. _____ Make sure the customer has the necessary couplers to attach the unit to the skid-steer auxiliary hydraulic couplers.
7. _____ Complete and return the manufacturer's "Warranty Validation Form" and sign your dealership predelivery checklist.

LIMITED WARRANTY

All new Bradco products are warranted to be free from defects in materials or workmanship which may cause failure under normal usage and service when used for the purpose intended.

In the event of failure within twelve (12) months from initial retail sale, lease or rental date (excluding cable, ground engaging parts such as sprockets, digging chain, bearings, teeth, tamping and demolition heads, blade cutting edges, pilot bits, auger teeth, auger heads & broom bristles), if after examination, Bradco determines failure was due to defective material and/or workmanship, parts will be repaired or replaced. Bradco may request defective part or parts be returned prepaid to them for inspection at their place of business at Delhi, Iowa, or to a location specified by Bradco.

Any claims under this warranty must be made within fifteen (15) days after the Buyer learns of the facts upon which such claim is based. All claims not made in writing and received by Bradco within the time period specified above shall be deemed waived.

THIS WARRANTY IS IN LIEU OF ALL OTHER WARRANTIES EXPRESSED OR IMPLIED AND THERE ARE NO WARRANTIES OF MERCHANTABILITY OR OF FITNESS FOR A PARTICULAR PURPOSE. IN NO EVENT SHALL BRADCO BE LIABLE FOR CONSEQUENTIAL OR SPECIAL DAMAGE.

BRADCO'S LIABILITY FOR ANY AND ALL LOSSES AND DAMAGES TO BUYER, RESULTING FROM ANY CAUSE WHATSOEVER, INCLUDING BRADCO'S NEGLIGENCE, IRRESPECTIVE OF WHETHER SUCH DEFECTS ARE DISCOVERABLE OR LATENT, SHALL IN NO EVENT EXCEED THE PURCHASE PRICE OF THE PARTICULAR PRODUCTS WITH RESPECT TO WHICH LOSSES OR DAMAGES ARE CLAIMED, OR, AT THE ELECTION OF BRADCO, THE REPAIR OR REPLACEMENT OF DEFECTIVE OR DAMAGED PRODUCTS.