TABLE OF CONTENTS

615 TRENCHER

TO THE OWNER	A
SAFETY PRECAUTIONS	B
To The Operator	
Before You Start	
During Trencher Operation	
Transporting The Trencher	
Maintaining The Trencher	
INTERNATIONAL SYMBOLS	C
PREOPERATION	D
Preparing The Loader	
Options	
Trencher Major Component Nomenclature	
MOUNTING KIT INSTALLATION	E
Mounting and Hydraulic Kits (Diagrams and Parts Lists)	
TRENCHER INSTALLATION	F
OPERATING INSTRUCTIONS	G
Controls	
Raising & Lowering the Trencher, Tilting the Trencher, Side Shifting the Trencher (If Equipped), Starting and Stopping the Trencher, Speed Control, Auger Height, Crumber Shoe/Bar Adjustment, Chain Tension Adjustment, Variable Depth Control (VDC) Skid Adjustment	
Operating Techniques	
Before You Start Trenching, Starting the Trench, Stalling the Trencher, Turning While Trenching, Recommended Digging Angles, Trenching Without Crumber Assembly, Ending a Trench, Transporting the Trencher, Trencher Performance	
615F Footing Trencher - Special Applications	
TRENCHER ASSEMBLY	I
615 Trencher Assembly and 24", 30", 36" & 48" Boom & Crumber Assemblies	
615F Footing Trencher Assembly and 24" & 30" Boom & Crumber Assemblies	
DIGGING CHAIN OPTIONS	J
Chain Pitch, Component Size, Digging Stations, Chain Assembly Options, Digging Stations (Diagrams and Parts Lists), Chain Assemblies (Set Up Diagrams), Chain Width Conversions	
MAINTENANCE	L
STORAGE	M
TROUBLESHOOTING	N
BOLT TORQUE SPECIFICATIONS	O
SPECIFICATIONS	P
DECALS	Q
PREDELIVERY CHECK LIST	R
LIMITED WARRANTY	S

TO THE OWNER

GENERAL COMMENTS

Congratulations on the purchase of your new trencher! Your trencher was carefully designed and manufactured to give you many years of dependable service. Your trencher will require some minor maintenance (such as cleaning and lubricating) to keep it in top working condition. Be sure to observe all safety precautions and maintenance procedures as described in this manual.

ABOUT THIS MANUAL

This manual has been designed to help you do a better, safer job. Read this manual carefully and become familiar with its contents. **Remember, never let anyone operate this trencher without reading the "Safety Precautions" and "Operating Instructions" sections of this manual. (See Sections B and G respectively.)**

Unless noted otherwise, "right-hand" and "left-hand" sides are determined from the position of the skid steer operator sitting in the seat facing forward.

SAFETY ALERT SYMBOL



This is the "Safety Alert Symbol" used by this industry. This symbol is used to warn of possible injury. Be sure to read all warnings carefully. They are included for your safety and for the safety of others working with you.

SERVICE

When servicing your trencher, remember to use only manufacturer replacement parts. Substitute parts may not meet the standards required for safe, dependable operation.

To facilitate parts ordering, record the model and serial number of your trencher in the space provided on this page. This information may be obtained from the trencher identification plate located on the right side of the trencher main frame.

MODEL _____ DATE PURCHASED _____

SERIAL NO. _____

MOUNTED ON _____

Your parts dealer needs this information to insure that you receive the correct parts for your specific trencher.

SAFETY PRECAUTIONS

TAKE NOTE! THIS SAFETY ALERT SYMBOL FOUND THROUGHOUT THIS MANUAL IS USED TO CALL YOUR ATTENTION TO INSTRUCTIONS INVOLVING YOUR PERSONAL SAFETY OR OTHERS. FAILURE TO FOLLOW THESE INSTRUCTIONS CAN RESULT IN INJURY OR DEATH.



THIS SYMBOL MEANS:

ATTENTION!

BECOME ALERT!

YOUR SAFETY IS INVOLVED!

SIGNAL WORDS: Note the use of signal words DANGER, WARNING, and CAUTION with the safety messages. The appropriate signal word for each has been selected using the following guidelines:

DANGER: Indicates an imminently hazardous situation, which if not avoided, will result in death or serious injury. This signal word is to be limited to the most extreme situations, **typically for machine components which, for functional purposes, cannot be guarded.**

WARNING: Indicates a potentially hazardous situation, which if not avoided, could result in death or serious injury, and **includes hazards that are exposed when guards are removed. It may also be used to alert against unsafe practices.**

CAUTION: Indicates a potentially hazardous situation, which if not avoided, **may result in minor or moderate injury. It may also be used to alert against unsafe practices.**

SAFETY PRECAUTIONS

TRENCHERS

GENERAL INFORMATION

This section is composed of various warnings and safety tips. **Read and learn all the information in this section before you attempt to use your trencher.** Also read your vehicle owner's manual before using your equipment. This knowledge will help you operate your unit safely. **Do not take this information lightly, it is presented for your own benefit and for the benefit of others working around you.**

The "Safety Alert Symbol" , as previously described, will be used throughout this manual. It will appear with one of the words **DANGER**, **WARNING**, or **CAUTION** above it, and a safety message pertaining to the specific topic being covered. Take the time to read these messages as you come across them.

TO THE OPERATOR

The primary responsibility for safety with the equipment falls to the operator. It is the skill, care, common sense, and good judgment of the operator that will determine how efficiently and safely the job is performed. Know your equipment before you start. Know its capabilities, dimensions, and how to operate all the controls. Visually inspect your equipment before you start, and never operate equipment that is not in proper working order with all safety devices intact.

BEFORE YOU START

1. **Wear the right clothing and gear for the job.** Protective equipment such as hard hat, steel toed shoes, leather gloves, or safety glasses may be in order. They can protect you from needless injury.
2. **Do not wear loose clothing, or things such as rings and watches around the equipment.** They could get caught in moving parts, and lead to serious injury or death.
3. **Know your equipment inside and out.** Know how to operate all controls, and know emergency shut down procedures. Make sure **all** safety devices are in place and working.
4. **Keep all step plates, grab bars, pedals, and controls free of dirt, grease, and oil.** Keep equipment clean to help avoid injury from a fall when getting on or off equipment.

SAFETY PRECAUTIONS

TRENCHERS

5. **Do not use the trencher or crumber bar as a step, or grab the digging chain when climbing on or off the trencher.** Damage to the equipment or personal injury could result.
6. **Know your work area before you begin.** Observe any potential hazard areas such as soft ground, drop-offs, rocks and other obstacles.
7. **Know where all utility lines are.** Observe overhead electrical and phone lines. Be sure equipment will safely clear them. Know the location of underground cables, wires, gas and water lines, tanks, etc. Contact with electrical lines could cause electrocution. Hitting a gas line or underground tank could cause an explosion.
8. **Be alert to others in the work area.** Be sure others know when and where you will be working. Make sure no one is underneath or behind equipment.
9. **Never try to board equipment while it's moving.**
10. **Never take passengers on your equipment.** There is no safe place for riders.
11. **Test all controls before you start.** This includes safety equipment and devices.

DURING TRENCHER OPERATION

1. **Be alert to what is going on around you.** Watch for others who may not be watching out for themselves.
2. **Never operate equipment while under the influence of alcohol or prescription drugs, which could inhibit physical and or mental capacity.**
3. **Stop the trencher and shut off the engine if anyone approaches the equipment while it's in motion.** They may not be familiar with the equipment, and get in the way of moving parts.
4. **Be alert to changes in the work area.** Changes in weather and soil conditions could turn a safe work site into a hazardous area.

SAFETY PRECAUTIONS

TRENCHERS

5. Keep equipment away from the trencher after it has been dug. The weight of the unit could cause a cave in.
6. Never drop a boom with a rapidly moving digging chain on the ground. The force of the trencher may cause the vehicle to move suddenly and unexpectedly. Have the chain moving slowly, and lower the boom carefully when starting a new cut.
7. Use caution when digging on a slope. The natural vibration of the trencher will make the unit creep sideways downhill. Try to dig with the trencher in a level position.
8. Never try to make sharp turns while trenching. The trencher boom could become wedged in the trench and damaged.
9. Never attempt to free a stuck chain with the unit running. If the trencher does become jammed, stop the unit and visually inspect the situation.
10. Check the trencher frequently for loose hardware and fittings. The natural vibration of the unit will cause fasteners to loosen during operation.

TRANSPORTING THE TRENCHER

1. Follow all federal, state, and local regulations when transporting the unit on public roads.
2. Use a SMV (Slow Moving Vehicle) sign on the vehicle when transporting. This will help alert others to your presence.
3. Be sure all lights and turn signals are in working order. Use them as required.
4. When parking, park the unit on hard level ground and lower the trencher boom. Block the wheels, and set the parking brake. Shut off the engine.
5. Follow factory recommended shut down procedures for equipment.
6. Stop the trencher and vehicle before dismounting.

SAFETY PRECAUTIONS

TRENCHERS

MAINTAINING THE TRENCHER

1. Replace all safety shields and guards when performing maintenance. Do not operate the trencher with protective equipment removed.
2. Lower the trenching boom, and shut off the engine before working on the unit. Never perform maintenance on a trencher while it is running.
3. Make sure all operating and residual pressures are relieved before working on a hydraulic system. Shut engine off, and operate all the controls to relieve any pressure.
4. Use only manufacturer recommended replacement parts. Other parts may be substandard in fit and quality.
5. Do not set any relief valve higher than recommended by the manufacturer. Relief valves should be checked and adjusted only by a trained service technician. Do not remove or block a relief valve.
6. Observe proper maintenance schedules. Proper maintenance can help prevent a hazardous condition.
7. Always wear safety goggles or glasses when working on equipment.

WARNING! Escaping fluid under pressure can have sufficient force to penetrate the skin, causing serious personal injury. Fluid escaping from a very small hole can be almost invisible. Use a piece of cardboard or wood, rather than hands to search for suspected leaks.





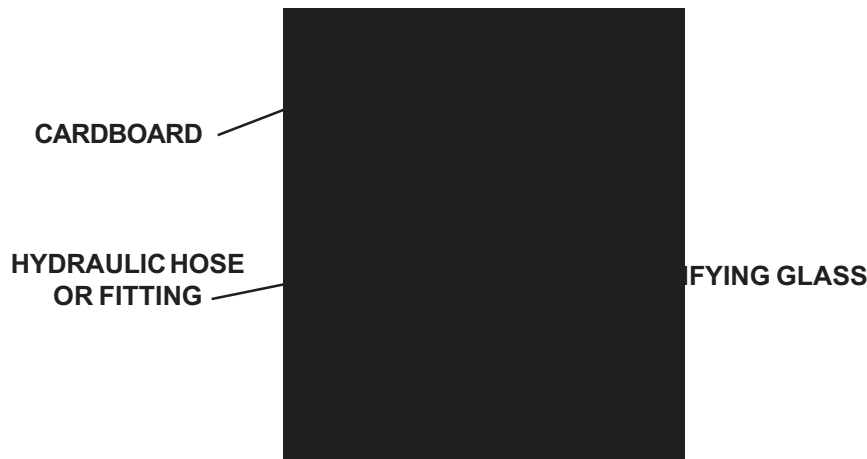

Keep unprotected body parts, such as face, eyes, and arms as far away as possible from a suspected leak. Flesh injected with hydraulic fluid may develop gangrene or other permanent disabilities.

If injured by injected fluid, see a doctor at once. If your doctor is not familiar with this type of injury, ask him to research it immediately to determine proper treatment.



INTERNATIONAL SYMBOLS

As a guide to the operation of your equipment, various international symbols have been utilized on the instruments and controls. The symbols are shown below with an indication of their meaning.

	Engine speed		Alternator charge
	Hours recorded		Power take-off (on)
	Engine water temperature		Power take-off (off)
	Lights		"Tortoise," slow or minimum setting
	Horn		"Hare," fast or maximum setting
	Engine oil pressure		Caution
	Hazard warning		Control lever operating direction
	Axle connect		Rock shaft (raised)
	Axle disconnect		Rock shaft (lowered)
	Continuously variable		Remote cylinder (extended)
	Increase		Remote cylinder (retracted)
	Decrease		Remote cylinder (FLOAT)
	Diesel fuel		Differential lock
	Creeper range		Read operators manual
	High range		Neutral
	Low range		Forward
			Reverse

PREOPERATION

615 TRENCHER

GENERAL INFORMATION

The purpose of this manual is to assist in setting up, operating and maintaining your trencher. Read it carefully. It furnishes information and instructions that will help you achieve years of dependable performance.

Right and left when referred to in this manual are determined by the operator's right and left when in the normal operating position facing forward.

The illustrations and date in this manual were current at the time of printing, however, we reserve the right to redesign and change the trencher as may be necessary without notification.

PREPARING THE LOADER

 **WARNING!** Never let anyone operate this loader and trencher without understanding all of the "Safety Precautions" and "Operating Instructions" located in this manual (see Sections B and G respectively). Always choose hard, level ground to park the loader on, and set the brake so that the loader cannot roll.

Your loader **MUST** have auxiliary hydraulics to run the trencher. If your unit does not have an auxiliary hydraulic system, contact your dealer for information on availability.

The hydraulic kits for the Trencher include two hoses that connect the trencher to the auxiliary hydraulic system.

The trencher was designed to be easy to use and maintain. The trencher mounts to the universal toolbar/attachment plate of the loader. The mounting incorporates the quick attach mechanism of the loader for fast, easy mounting. **The 615F Footing Trencher requires a mounting kit with side shift capabilities.**

See your operators manual on "Installing an Attachment" for the correct installation procedure.

PREOPERATION

615 TRENCHER

OPTIONS

Eventually you may wish to dig a trench of a depth or width other than what your unit was originally equipped to dig. The 615 trencher can be fitted with optional booms, digging chains, and crumber assemblies to allow you to dig a variety of different sized trenches with a tooth every station digging chain. The chart on this page will give you an idea of the different trench depths and widths a properly equipped unit is capable of digging. For more detailed information on trencher options, see Sections I & J of this manual.

615 TRENCHER

TRENCH DEPTHS*		TRENCH WIDTHS			
24" Depth		6.00"	8.00"	10.00"	12.00"
30" Depth		6.00"	8.00"	10.00"	NA
36" Depth	4.50"	6.00"	8.00"	NA	NA
48" Depth	4.50"	6.00"	NA	NA	NA

*Trench depths are given with the digging boom at an optimum 65° digging angle and the skid shoe touching the ground. Trenches of various depths can be made by varying the digging angle and raising the trencher up higher. These methods are less efficient however.

615F FOOTING TRENCHER

TRENCH DEPTHS*		TRENCH WIDTHS			
24" Depth		6.00"	8.00"	10.00"	12.00"
30" Depth		6.00"	8.00"	10.00"	NA

*Trench depths are given with the digging boom at an optimum 65° digging angle and the skid shoe touching the ground. Trenches of various depths can be made by varying the digging angle and raising the trencher up higher. These methods are less efficient however.

PREOPERATION

TRENCHER MAJOR COMPONENT NOMENCLATURE 615 TRENCHER

GENERAL INFORMATION

The purpose of this page is to acquaint you with the trencher and the names of its various components. This knowledge will be helpful when reading through this manual or when ordering service parts.

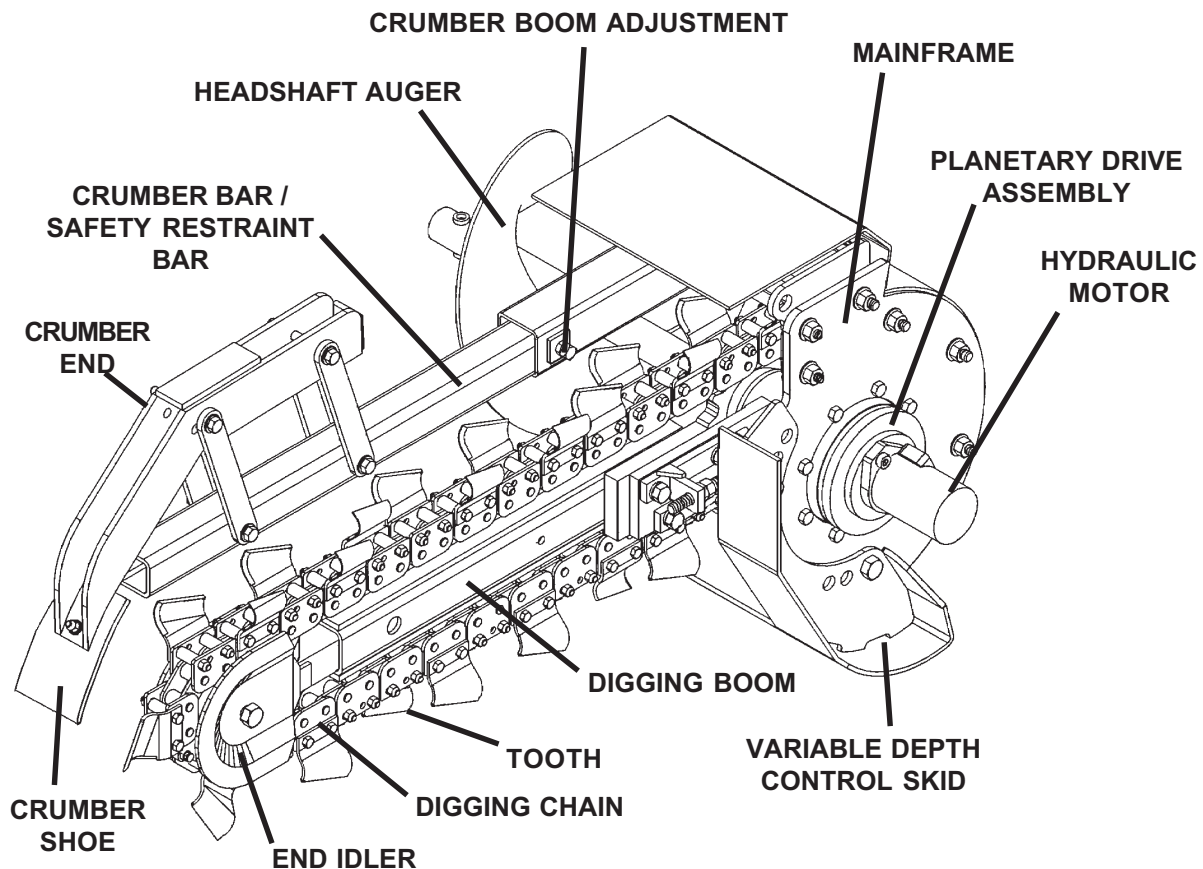

615F FOOTING TRENCHER

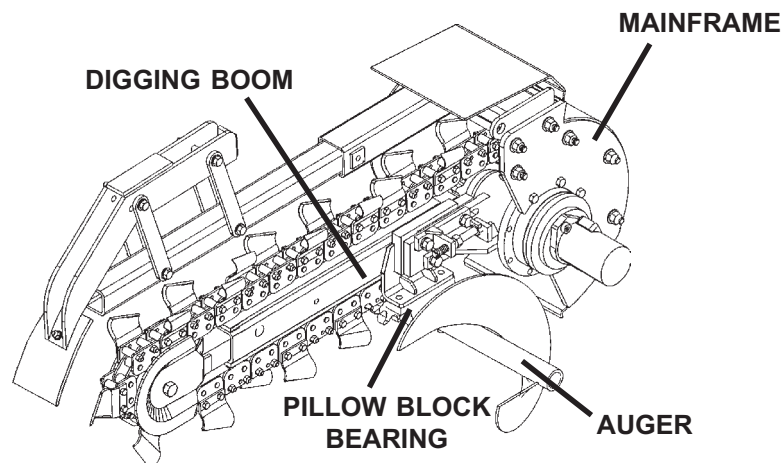

MOUNTING KIT INSTALLATION

MOUNTING KIT ASSEMBLY #15273

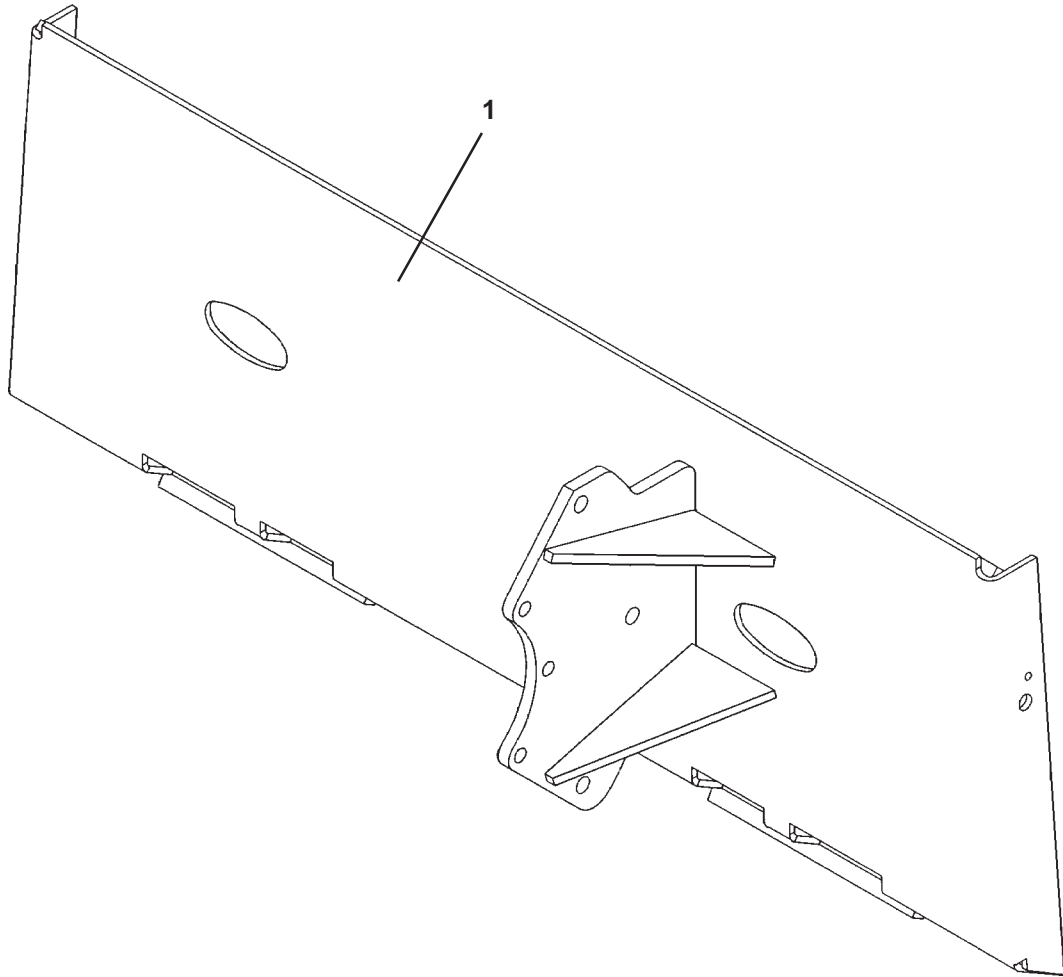

MOUNTING KIT INSTALLATION

MOUNTING KIT ASSEMBLY #15273

<u>NO</u>	<u>REQ'D</u>	<u>PART NO.</u>	<u>DESCRIPTION</u>
1	1	15273	Attachment Frame

MOUNTING KIT INSTALLATION

MOUNTING KIT ASSEMBLY #15495

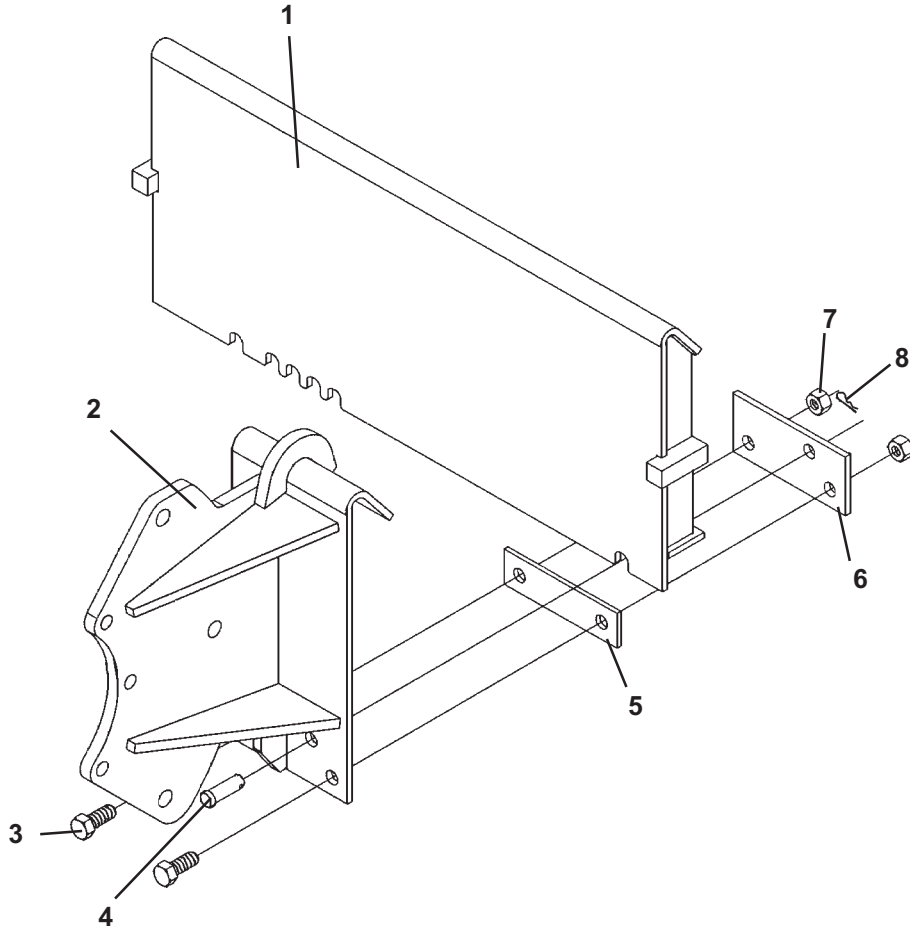

MOUNTING KIT INSTALLATION

MOUNTING KIT ASSEMBLY #15495

<u>NO</u>	<u>REQ'D</u>	<u>PART NO.</u>	<u>DESCRIPTION</u>
1	1	18134	Mounting Bracket
2	1	18136	Side Shift Bracket
3	2	1811	.50" UNC X 1.50" Hex Capscrew Grade 8
4	1	1849	Clevis Pin
5	1	15604	Spacer Block
6	1	15603	Clamp Plate
7	2	1242	.50" UNC Jam Nut
8	1	1735	Hair Pin

MOUNTING KIT INSTALLATION

MOUNTING KIT ASSEMBLY #16287

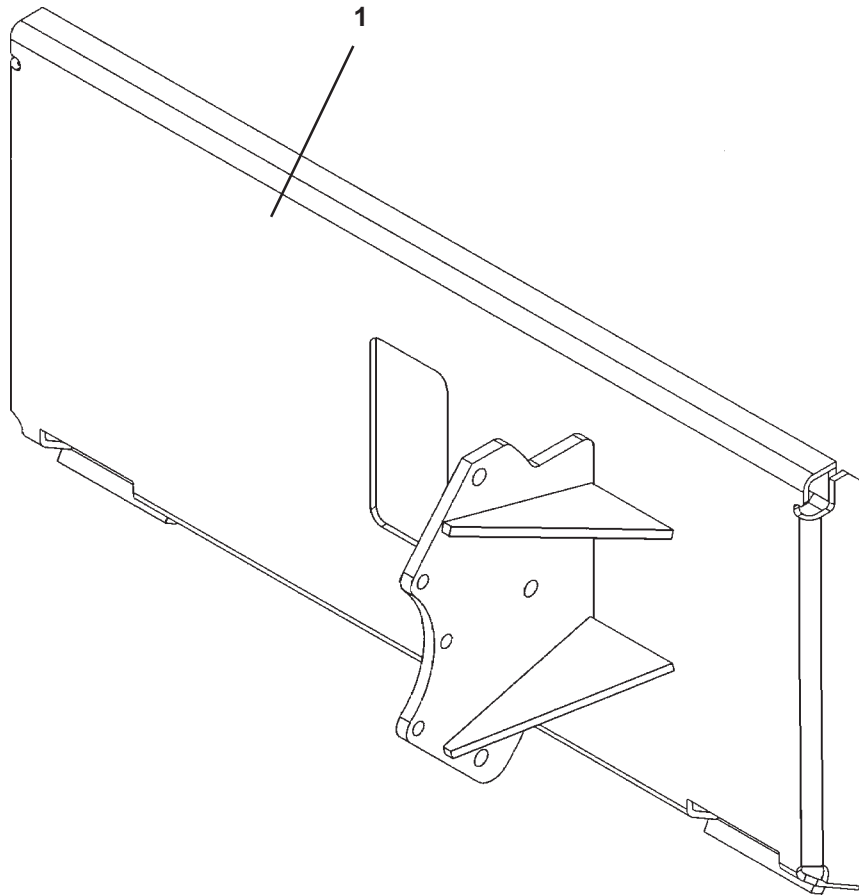

MOUNTING KIT INSTALLATION

MOUNTING KIT ASSEMBLY #16287

<u>NO</u>	<u>REQ'D</u>	<u>PART NO.</u>	<u>DESCRIPTION</u>
1	1	16287	Attachment Frame

MOUNTING KIT INSTALLATION

MOUNTING KIT ASSEMBLY #18696

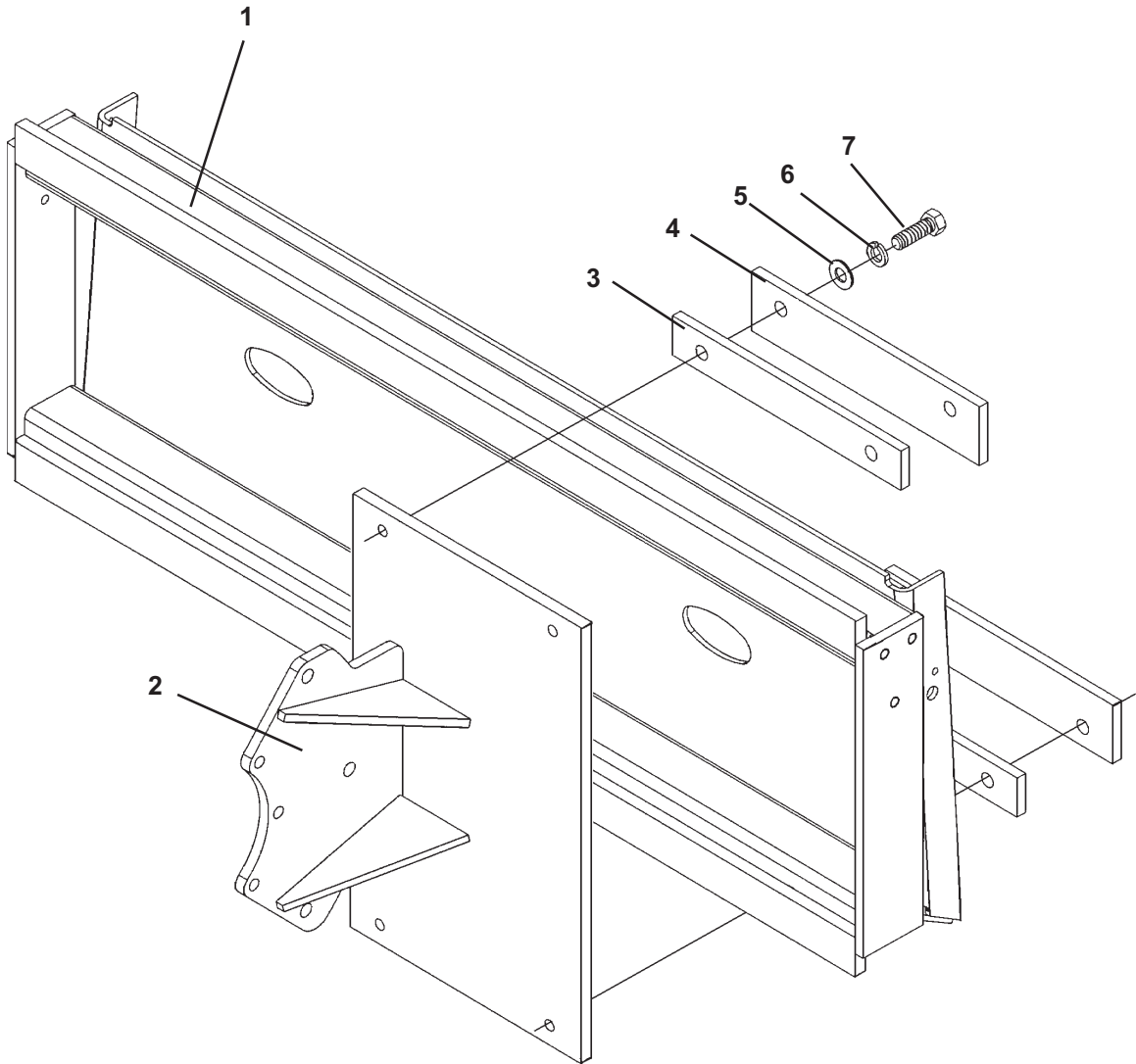

MOUNTING KIT INSTALLATION

MOUNTING KIT ASSEMBLY #18696

<u>NO</u>	<u>REQ'D</u>	<u>PART NO.</u>	<u>DESCRIPTION</u>
1	1	15292	Mounting Bracket
2	1	15274	Side Shift Bracket
3	2	15277	Spacer Block
4	2	15276	Clamp Plate
5	4	1517	.62" Flat Washer
6	4	1506	.62" Lock Washer
7	4	1116	.62" UNC X 2.00" Hex Capscrew

MOUNTING KIT INSTALLATION

MOUNTING KIT ASSEMBLY #18967

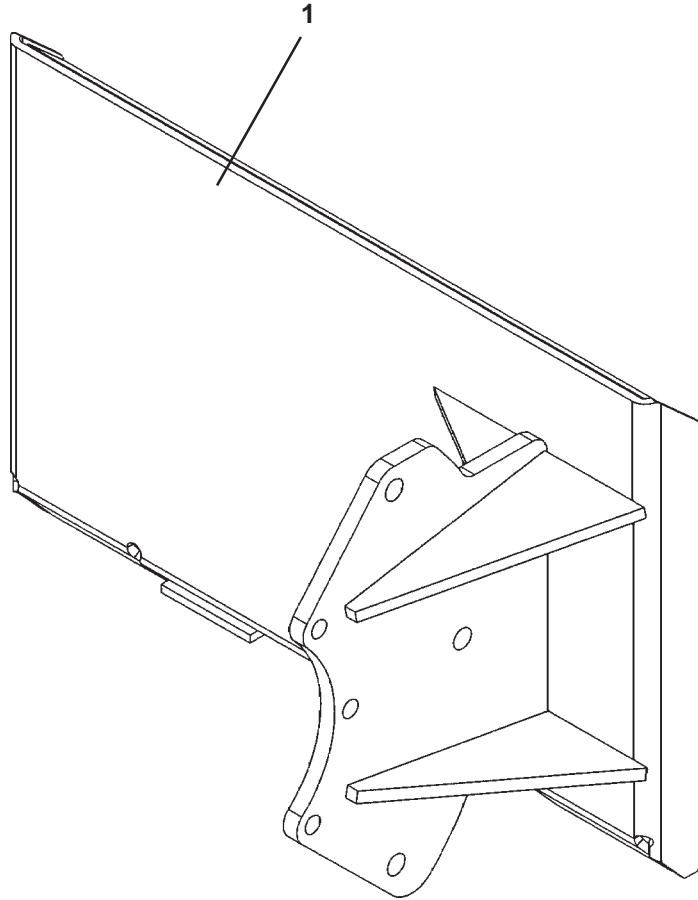

MOUNTING KIT INSTALLATION

MOUNTING KIT ASSEMBLY #18967

<u>NO</u>	<u>REQ'D</u>	<u>PART NO.</u>	<u>DESCRIPTION</u>
1	1	18967	Attachment Frame

MOUNTING KIT INSTALLATION

MOUNTING KIT ASSEMBLY #24302

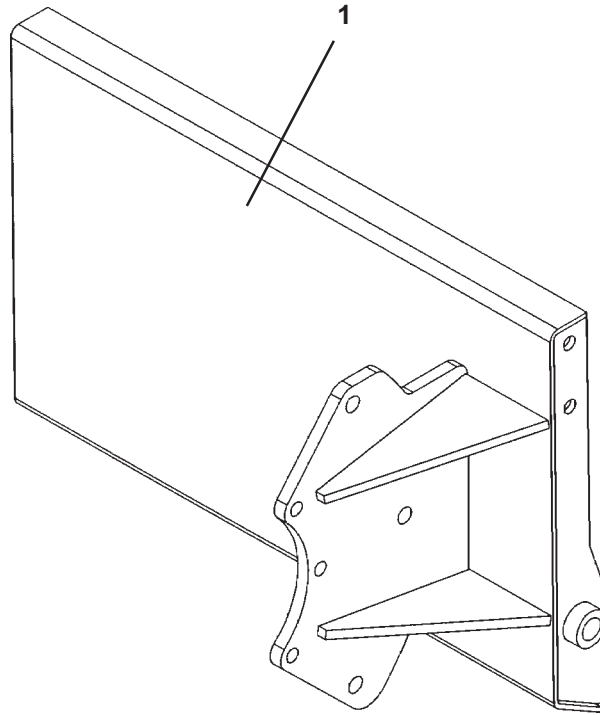

MOUNTING KIT INSTALLATION

MOUNTING KIT ASSEMBLY #24302

<u>NO</u>	<u>REQ'D</u>	<u>PART NO.</u>	<u>DESCRIPTION</u>
1	1	24302	Attachment Frame

MOUNTING KIT INSTALLATION

MOUNTING KIT ASSEMBLY #24303

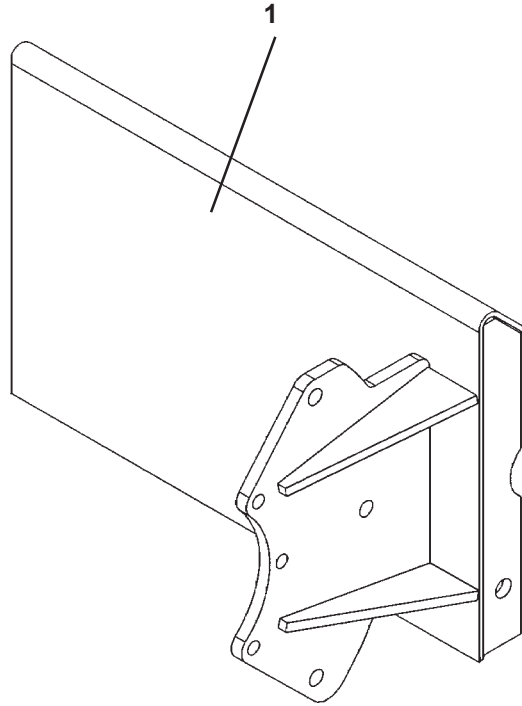

MOUNTING KIT INSTALLATION

MOUNTING KIT ASSEMBLY #24303

<u>NO</u>	<u>REQ'D</u>	<u>PART NO.</u>	<u>DESCRIPTION</u>
1	1	24303	Attachment Frame

MOUNTING KIT INSTALLATION

MOUNTING KIT ASSEMBLY #24305

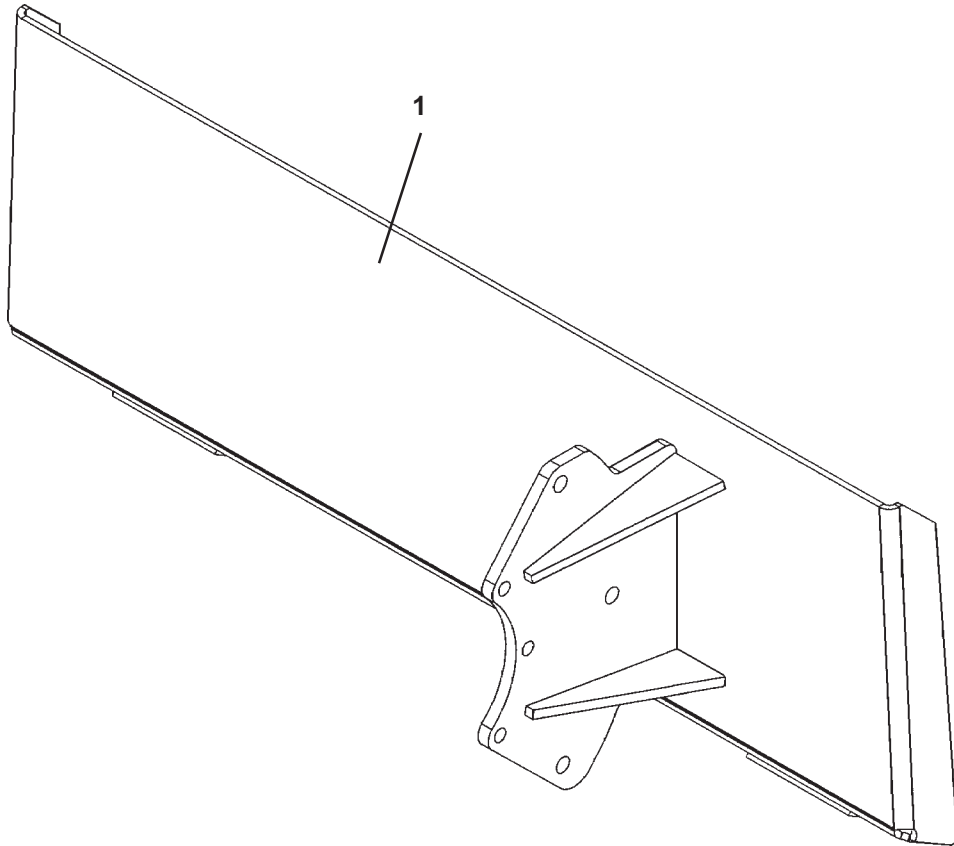

MOUNTING KIT INSTALLATION

MOUNTING KIT ASSEMBLY #24305

<u>NO</u>	<u>REQ'D</u>	<u>PART NO.</u>	<u>DESCRIPTION</u>
1	1	24305	Attachment Frame

MOUNTING KIT INSTALLATION

MOUNTING KIT ASSEMBLY #89952

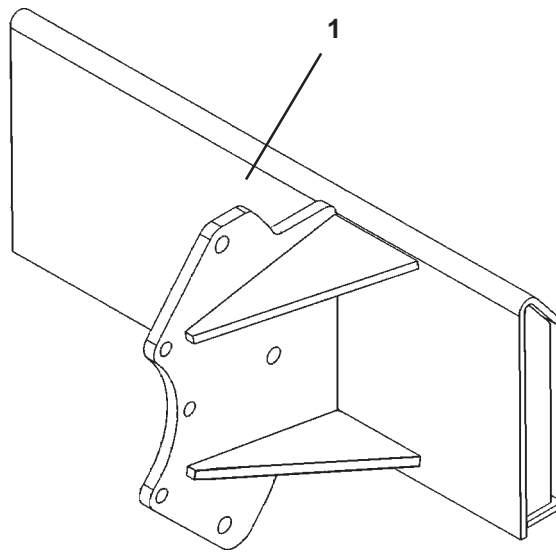

MOUNTING KIT INSTALLATION

MOUNTING KIT ASSEMBLY #89952

<u>NO</u>	<u>REQ'D</u>	<u>PART NO.</u>	<u>DESCRIPTION</u>
1	1	89952	Attachment Frame

MOUNTING KIT INSTALLATION

HYDRAULIC HOSE KIT

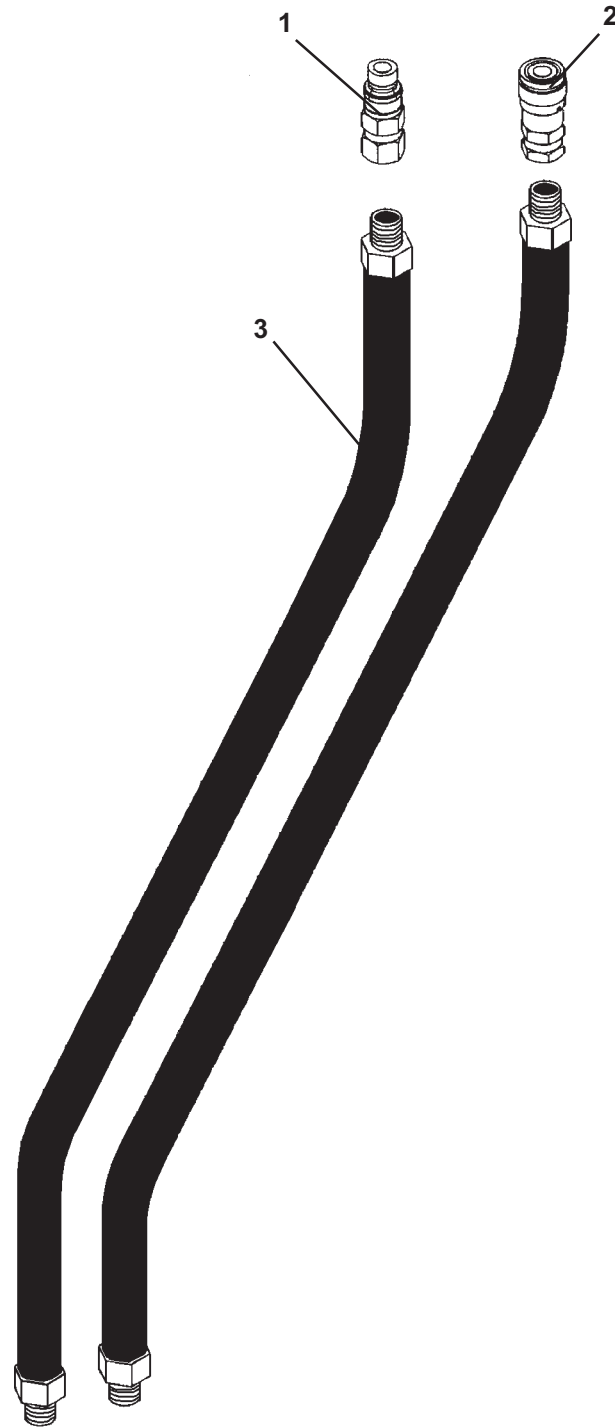

MOUNTING KIT INSTALLATION

HYDRAULIC HOSE KIT

IMPORTANT: THE HYDRAULIC COUPLERS AND HOSES ARE SPECIFIC TO YOUR LOADER APPLICATION. THE PARTS LISTED BELOW ARE FOR REFERENCE ONLY. CONTACT FACTORY OR YOUR LOCAL BRADCO DEALER TO ORDER THESE ITEMS.

<u>NO</u>	<u>REQ'D</u>	<u>PART NO.</u>	<u>DESCRIPTION</u>
1	-	24001 15512	Male Coupler 10FBo - .50" Flat Face Male Coupler 10FBo - .50" Poppet
2	-	24002 31886	Female Coupler 10FBo - .50" Flat Face Female Coupler 10FBo - .50" Poppet
3	-	38011 38089	Hose Assembly .50" X 56" 10MBo-10MBo Hose Assembly .50" X 78" 10MBo-10MBo

TRENCHER INSTALLATION

615 TRENCHER

GENERAL INFORMATION

The following instructions will help you to mount your trencher on your loader. The trencher uses the quick attach mechanism for ease of installation. Therefore, if you know how to attach the loader bucket, attaching the trencher should prove no problem.

MOUNTING INSTRUCTIONS

1. If you have not done so already, remove the steel shipping banding from around the trencher and skid.
2. Remove any attachments from the front of the loader.
3. Following all standard safety practices and the instructions for attaching an attachment in your loader operator's manual, install the trencher onto your loader.

NOTE: IT IS IMPORTANT TO MAKE SURE THE LOCKING MECHANISM ON YOUR QUICK ATTACH IS ENGAGED, THEREFORE LOCKING THE TRENCHER ONTO THE LOADER.

NOTE: MAKE SURE ALL FOREIGN MATTER IS CLEANED FROM HYDRAULIC COUPLERS BEFORE MAKING CONNECTIONS.

4. With the auxiliary hydraulic system turned off, route the hydraulic hoses in such a fashion to avoid pinching and chafing and connect them to their proper auxiliary couplers on the loader.
5. Check chain tension and make any necessary adjustments. Refer to Maintenance Section of this manual (Section L).
6. Complete the "Predelivery Checklist" located at the back of the Operator's & Parts Manual (Section R). Trencher installation is now complete.

OPERATING INSTRUCTIONS

CONTROLS 615 TRENCHER

GENERAL INFORMATION

Simplicity of operation is one of the key features of the 615 trencher. The trenchers themselves have no controls, just a few adjustments to check. It is important however, to be familiar with, and know the controls and adjustments on both the trencher and the loader. Such knowledge is crucial for safe, efficient operation of equipment. Take the time to learn how they operate now.

LOADER

Your trencher mounts to the toolbar / attachment plate of the loader. Due to this arrangement, thorough knowledge of the loader controls is necessary for trencher operation. Read your loader owner's manual for information regarding operation before attempting to use the trencher.

RAISING / LOWERING THE TRENCHER

Raise / lower the trencher unit by raising / lowering the loader arms through their appropriate controls. (See Figure #1)

CAUTION! Become aware of any overhead power or telephone lines, tree limbs, etc., that the raised trencher could come into contact with. Contact with electrical lines could cause serious injury or death.



FIGURE #1

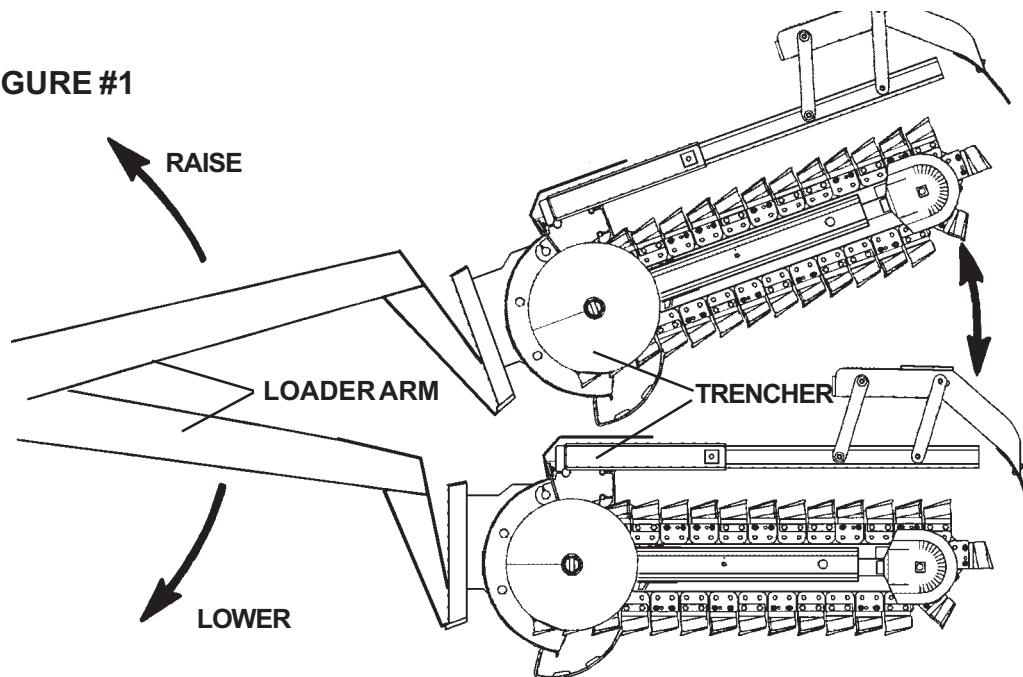

OPERATING INSTRUCTIONS

CONTROLS 615 TRENCHER

TILTING THE TRENCHER

Tilt the trencher unit up or down by tilting the toolbar / attachment plate back or forward through its loader control. We recommend a 60° digging angle for general trenching as measured from ground level (the horizon). (See Figure #2)

FIGURE #2

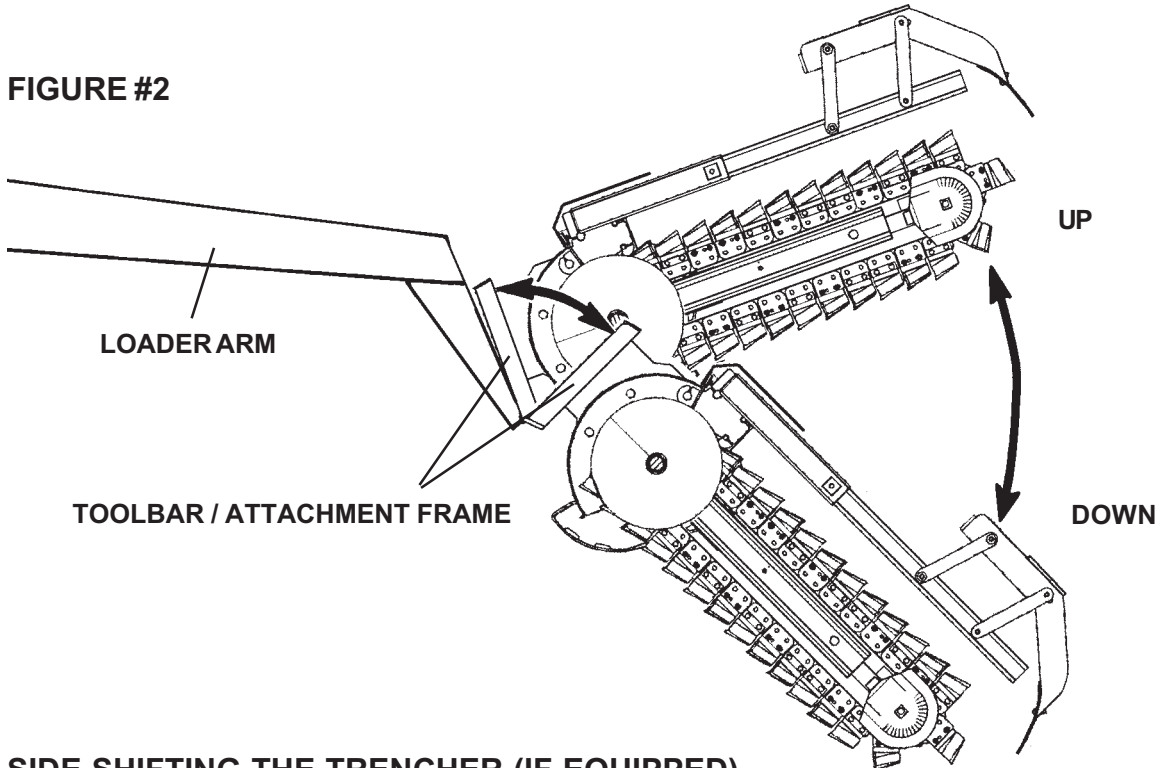

SIDE SHIFTING THE TRENCHER (IF EQUIPPED)

Some trencher mounts have an adjustment to shift the whole unit to the side.

To shift the unit sideways with Mounting Kit #15495: Lower the trencher until trencher frame is resting on the ground and remove the clevis pin. Counter-rotate the tires so that the loader moves in a sideways motion until the side shift holes are aligned and replace clevis pin.

IMPORTANT: Always reinstall the clevis pin to prevent the trencher from shifting sideways during operation.

NOTE: Slight shifting of the trencher from side to side may be necessary to align the side shift holes for reinstalling the clevis pin.

To shift the unit sideways with Mounting Kit #18696: Lower the trencher until trencher frame is resting on the ground and loosen the four capscrews securing the side shift bracket to the attachment frame. Counter-rotate the tires so that the loader moves in a sideways motion until the desired location is obtained. Tighten all hardware.

IMPORTANT: Always retighten all hardware to prevent the trencher from shifting sideways during operation.

OPERATING INSTRUCTIONS

CONTROLS 615 TRENCHER

STARTING AND STOPPING THE TRENCHER

Power to the trencher is supplied by oil from the loader auxiliary hydraulic system, which passes through the hydraulic hoses and into the trencher's hydraulic motor.

The trencher unit itself does not have an on/off control, but is operated by the loader's auxiliary hydraulic control mechanism. To start the trencher, engage the auxiliary hydraulics. (See your loader owner's manual.) To stop the trencher, disengage the auxiliary hydraulics.

TRENCHER SPEED CONTROL

Again it may be noted that power to the trencher is supplied by the loader's auxiliary hydraulics. Trencher speed and power are determined by the flow of oil coming out of the auxiliary system, which in turn is dependent upon loader engine speed. To increase trencher speed, increase loader engine speed, to decrease trencher speed, decrease loader engine speed.

When first starting a trench, throttle down the engine to half throttle. This will reduce the shock to the loader and trencher when the digging teeth first contact the ground. Once the trench is started, set the engine back to full throttle.

For general use, operate the trencher with the loader engine at full throttle to provide maximum power to the auxiliary hydraulics and thus the trencher.

AUGER HEIGHT

The auger on the 615 trencher is double ended. When a 4.50" - 6" chain is used, the auger must be installed with the narrow end closest to the chain. When an 8" - 12" chain is used, the auger must be turned end for end and installed with the wide end closest to the chain. (If the auger is not installed correctly it will interfere with the digging chain causing damage to the unit.) The auger is bolted to the trencher mainframe, and has no separate adjustment for auger height. To raise the auger, raise the trencher as previously described. This will raise the auger, and thus leave the dirt or spoil closer to the trench.

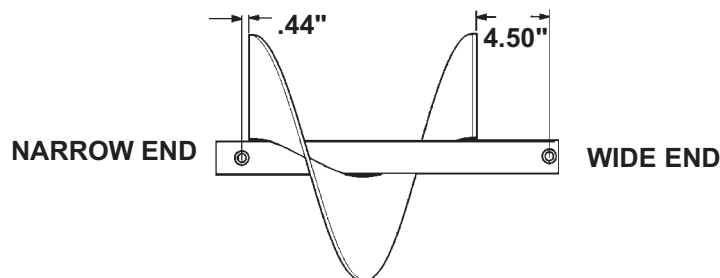

Lowering the trencher will cause the auger to lower, moving the spoil away from the trench. The variable depth skid shoe on the 615 trencher will prevent the auger from being lowered to the extent that the auger itself starts to dig in the ground, as this will greatly reduce efficiency.

OPERATING INSTRUCTIONS

CONTROLS 615 TRENCHER

It should be noted that raising or lowering the trencher to change the auger height will also change the trenching depth. You will need to compensate for this by changing the tilt of the trencher down or up accordingly. (See Figure #3)

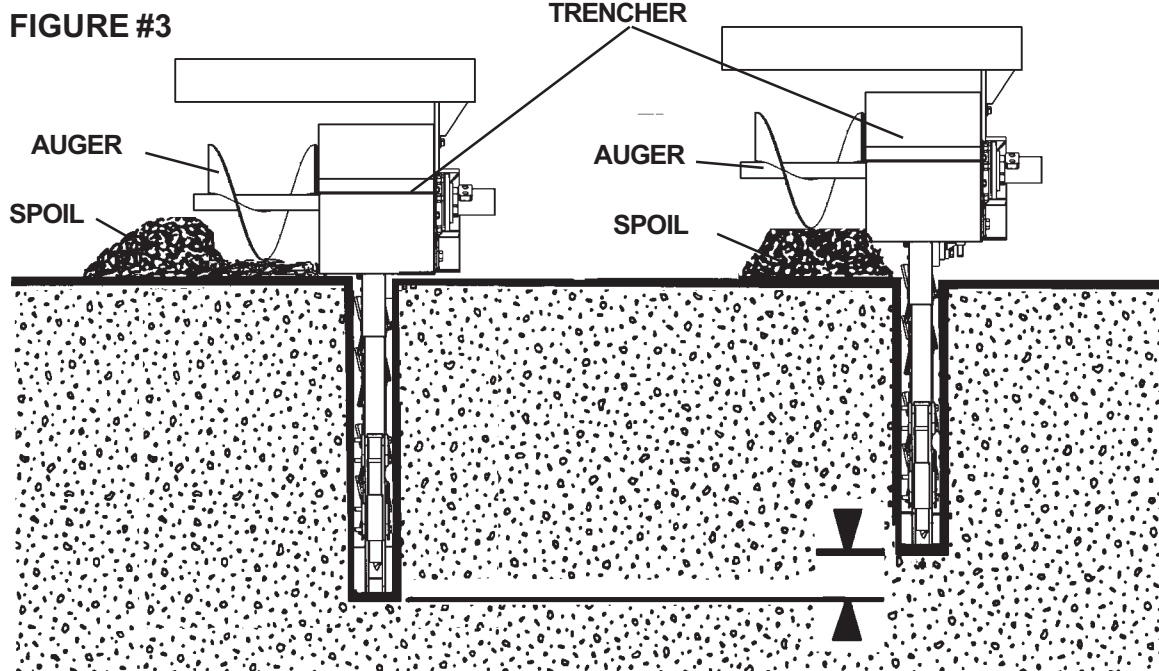

CRUMBER SHOE/BAR ADJUSTMENT

The purpose of the crumber shoe is to keep any loose dirt in the trench close enough to the digging chain so that the digging teeth can grab it and remove it. This will give you a cleaner finished trench. Your trencher has an adjustable crumber bar that can be lengthened or shortened to bring the crumber shoe closer or farther from the digging chain.

To adjust the crumber bar length, loosen the two jam nuts found at the end of the mainframe crumber bar tube. Slide the bar in or out to achieve the desired spacing (we suggest a distance of about 4" between crumber shoe and digging teeth for best overall results). Tighten the set screws and jam nuts when finished. (See Figure #4)

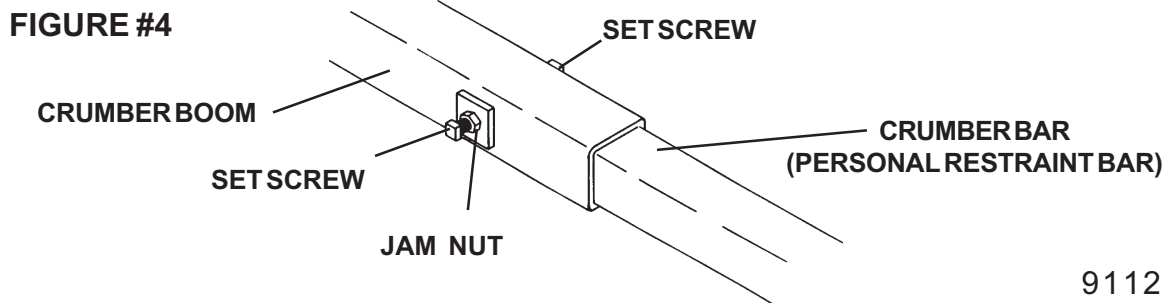

OPERATING INSTRUCTIONS

CONTROLS 615 TRENCHER

CHAIN TENSION ADJUSTMENT

When trenching, the digging chain tension should be adjusted so that the chain is as loose as possible, without jumping off the sprocket or idler wheel. To do this, an adjustment is provided on the digging boom.

These booms have an adjusting bolt on the left side at the trencher end of the boom. The head of the bolts are kept from rotating by stops welded onto the planetary drive assemblies. The adjusting bolt has a jam nut and a hex nut on it. To tighten the chain, loosen the .62" x 2.00" capscrews and "back off" the jam nut from the regular nuts on the adjustment bolt. Now turn the standard nuts off the adjusting bolt. This will push the boom out, and thus tighten the chain. Retighten the jam nut and the .62" x 2.00" capscrews when finished. **NOTE: Operating the trencher without properly tightening the .62" x 2.00" bolts will cause damage to the trencher boom and adjusting bolt.** To loosen the chain, follow the same procedure, except turn the hex nut onto the adjusting bolt. (See Figure #5)

FIGURE #5

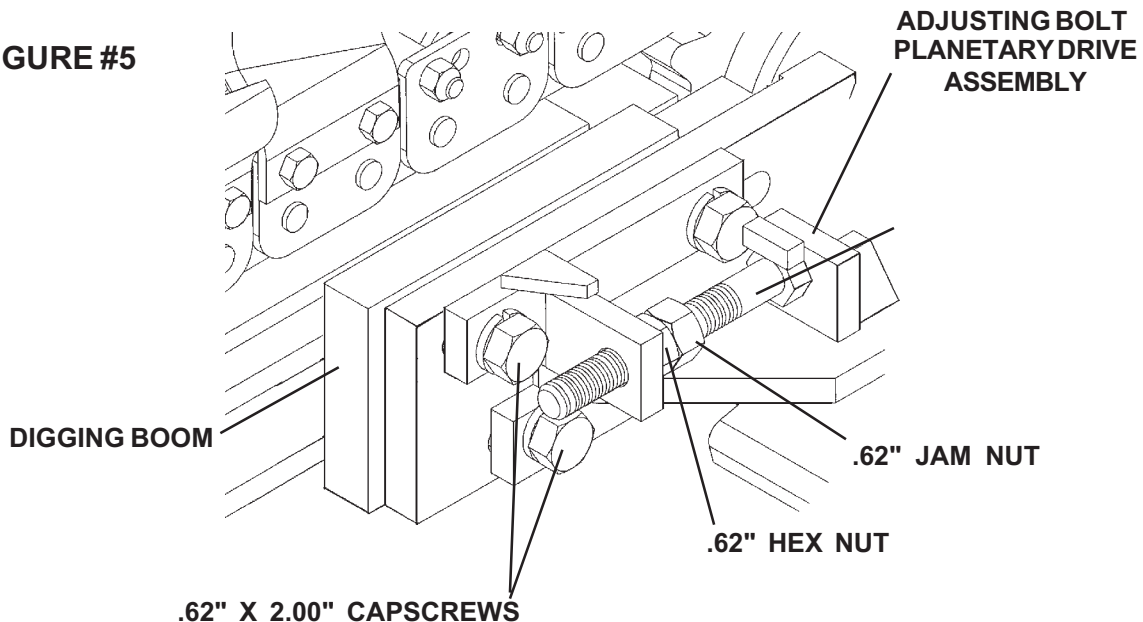

.62" X 2.00" CAPSCREWS
(BE SURE ALL FOUR CAPSCREW ARE TORQUED TO SPECIFICATION AFTER ADJUSTING THE DIGGING CHAIN.)

CAUTION! Never work on or make adjustments to any part of the trencher, while the unit is running. You could get caught in the digging teeth, which could cause severe injury or death.



It is common for your trencher to need its digging chain tightened after the first 10 to 20 minutes of operation, as the chain and sprocket seat themselves.

OPERATING INSTRUCTIONS

CONTROLS 615 TRENCHER

VARIABLE DEPTH CONTROL SKID ADJUSTMENT

The Variable Depth Control (VDC) Skid is used to control the trench depth, by maintaining one of three set angles. For example, by changing the position of the VDC skid with a 36" boom you can change the depth of your trench from 24" to 30" to 36" and still move the spoil away from the trench.

To adjust the trench depth on your trencher, you will need to remove the two 7/8" bolts that secure the VDC skid to the trencher mainframe. Remove the VDC skid and rotate it until the holes line up for the trench depth that you require. Reinstall the 7/8" bolts and deformed lock nuts, securing the VDC skid to the mainframe. See Figure #6

FIGURE #6

36" BOOM WITH THE VARIABLE DEPTH CONTROL (VDC) SKID SET TO:

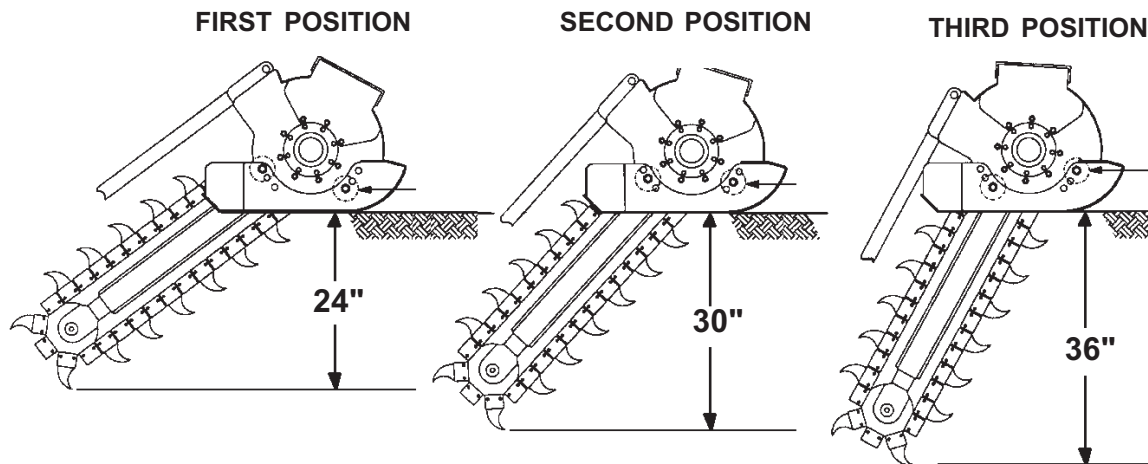

OPERATING INSTRUCTIONS

OPERATING TECHNIQUES 615 TRENCHERS

GENERAL INFORMATION

The design of your trencher makes it relatively simple to use. With the help of the information in this section and a little practice, you should become proficient in its operation in no time. Observe the following points to obtain the best results with the least amount of wear on the machine. Read the "Safety Precautions" section of this manual before you begin. (See Section B)

CAUTION! Operate the trencher only from the operator's station.



Do not operate a skid-steer without proper ROPS (Roll-Over-Protective-Structure), seat belt, and hard hat.

Pay attention to the job at hand. Be alert to the possibilities of others in the work area.

Never let anyone work around, or perform maintenance on the trencher while it is running.

Always use a crumber assembly on the trencher.

BEFORE YOU START TRENCHING

Before any excavating is started, it is always a good idea to plan out the job first. Various things need to be considered and taken into account prior to the actual trenching. The operator should inspect the job site, take notice of any potential hazards in the area, and have a complete understanding of the task to be performed. Figure out what will be done with the spoil (excavated soil), will it be used to backfill or be trucked out? What are the soil conditions like? Will you have to work around others? Etc.

WARNING! Check the prospective trenching area for hidden utility lines before operating the trencher. Contacting a utility line with the trencher could cause electrocution, resulting in death. Call all utility companies and have them plot out all their lines first. If you damage a utility line, shut off the equipment at once and contact the affected utility immediately.



Once you have become familiar with the job site and understand the job requirements, it is time to set up for the actual trenching. Check the soil type (hard, soft, rocky, etc.) and the trenching requirements (how deep, wide, etc.). Install the proper digging chain, boom, crumber bar, and shoe for the job at hand. Information on chains, booms, crumber bars, and shoes may be found in Sections I and J.

OPERATING INSTRUCTIONS

OPERATING TECHNIQUES 615 TRENCHERS

If equipped with a sideshift mount, locate the trencher on the mount with the side shift mechanism (as explained earlier in this section) where it will be most efficient and easy to use.

Adjust the variable depth control (VDC) skid to obtain the desired depth and angle for the job at hand (as explained earlier in this section).

Check digging chain tension and crumber bar and shoe adjustments (as explained earlier in this section).

Mark off the area to be trenched out. This can be done with powdered lime, chalk, or a guide string and stakes. Block off the area from all bystanders if possible.

STARTING THE TRENCH

Position the loader with the trencher boom directly over the center of the trench layout. It will take about 4' of trenching before the trencher will be able to operate at the desired level, so plan for this and position the trencher about 4' behind where you want the actual trench to start.

NOTE: The loader is driven in reverse when trenching. You cannot trench driving forward.

Raise the trencher with the loader arms and tilt the trencher at a 45° angle. (See Figure #6) Position the unit so that the digging teeth are just above ground level.

Set the loader throttle at half speed. Start the digging chain by engaging the auxiliary hydraulic system.

FIGURE #6

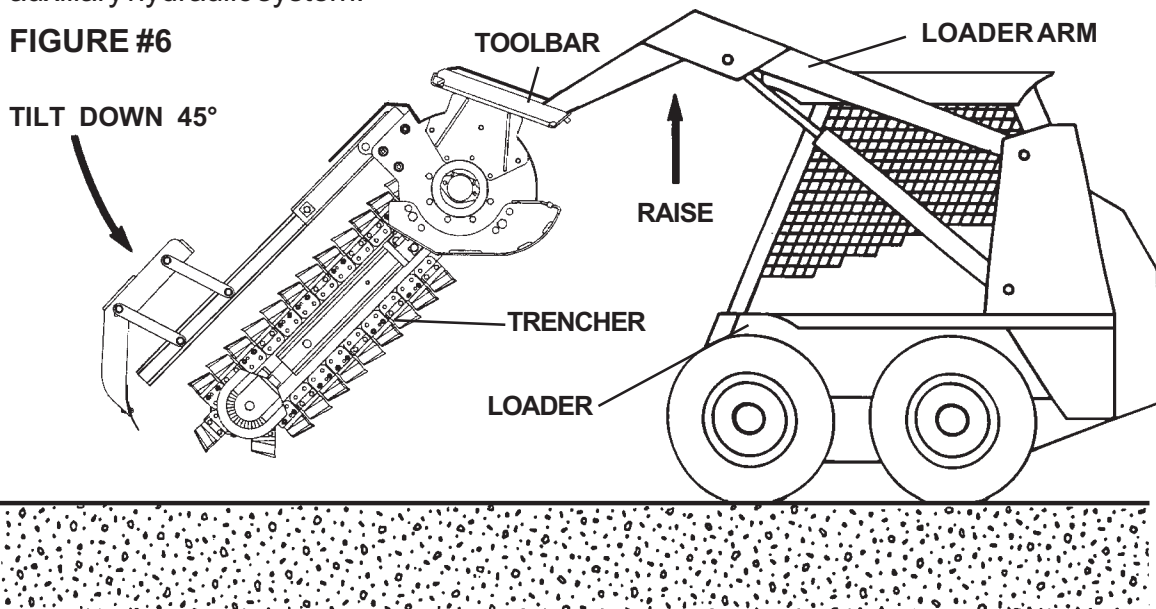

OPERATING INSTRUCTIONS

OPERATING TECHNIQUES 615 TRENCHERS

CAUTION! When lowering a moving digging chain to the ground, the force of the teeth grabbing the ground will try to pull the trencher suddenly forward. Be prepared. Have the brake set to help counteract the force.



Slowly lower the digging chain into the ground to start the trench. Do this by lowering the trencher with the loader arms. Continue lowering the unit until the crumber end rolls all the way back on the crumber bar. (See Figure #7)

IMPORTANT: After the crumber end has rolled all the way back, do not lower the trencher any farther without moving the loader in reverse. Failure to do so could result in bending of the crumber boom, which is not covered by warranty.

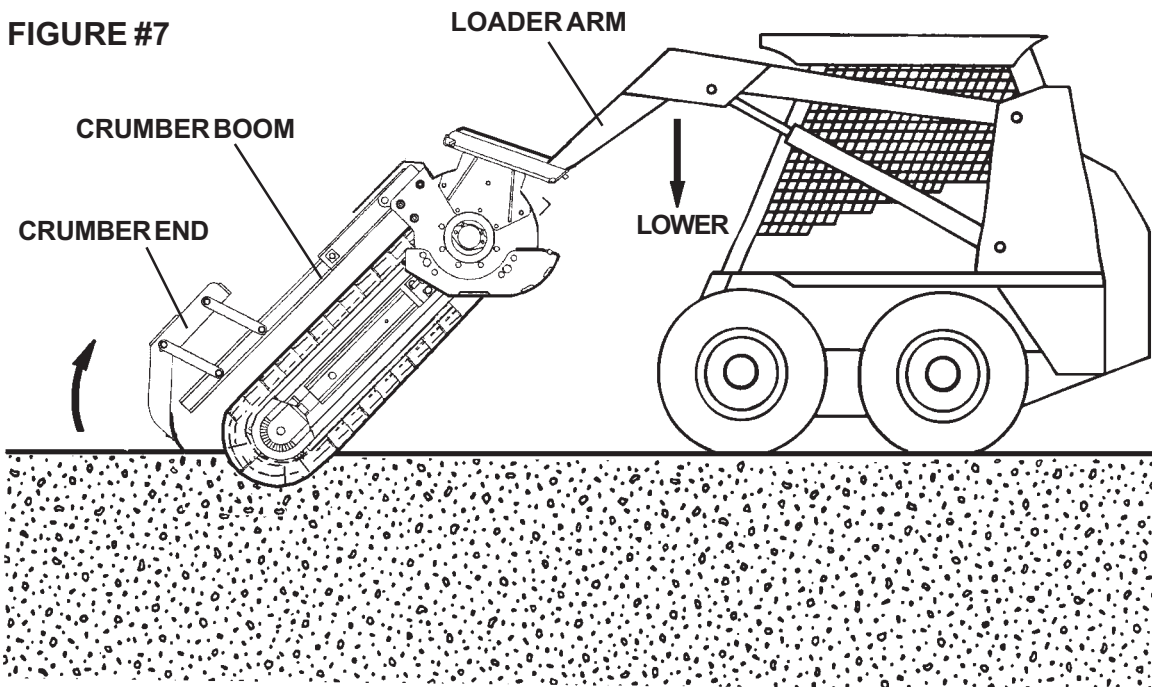

Once the crumber end has "bottomed out", begin slowly creeping the loader in reverse while continuing to lower the loader arms. When nearing the required depth, stop lowering and tilt the trencher to a 60° to 65° angle (third position on the VDC skid). A 60° - 65° angle works best for general trenching. (See Figure #8)

WARNING! Be alert to what is happening around you. Look behind you before reversing the loader to trench. Be aware of any person or thing in the path of the loader. Observe any terrain changes, such as drop-offs or soft ground.



OPERATING INSTRUCTIONS

OPERATING TECHNIQUES 615 TRENCHERS

FIGURE #8

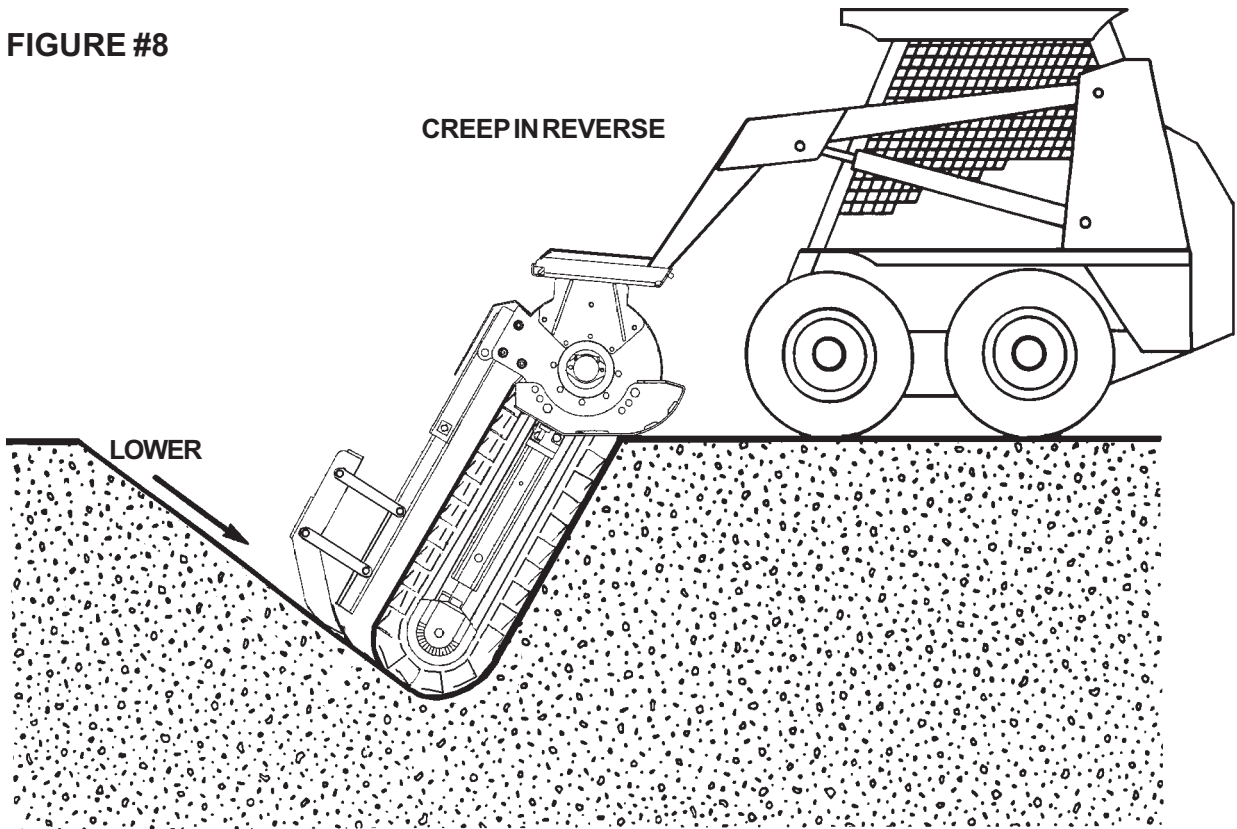

When trenching, remember to keep in mind the spoil placement. Position the trencher so that the auger floats at ground level to move spoil away from the trench. (See Figure #9)

FIGURE #9

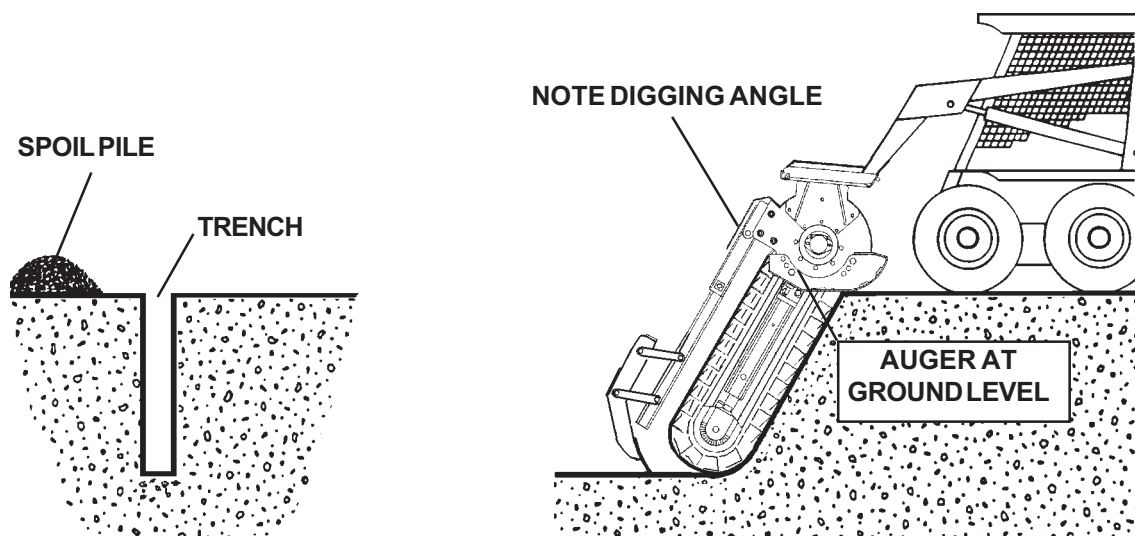

OPERATING INSTRUCTIONS

OPERATING TECHNIQUES 615 TRENCHERS

Raise the trencher so that the auger rides above the ground level, to leave the spoil beside the trench. The higher the auger, the closer to the trench the spoil will be placed. You may find that it generally takes less power to run the digging chain if the auger runs 3" - 6" (inches) off the ground, and thus increasing the potential footage of trench produced per hour. The higher you want the auger, the more vertical you will have to tilt the trencher to achieve the same trench depth. (See Figure #10)

FIGURE #10

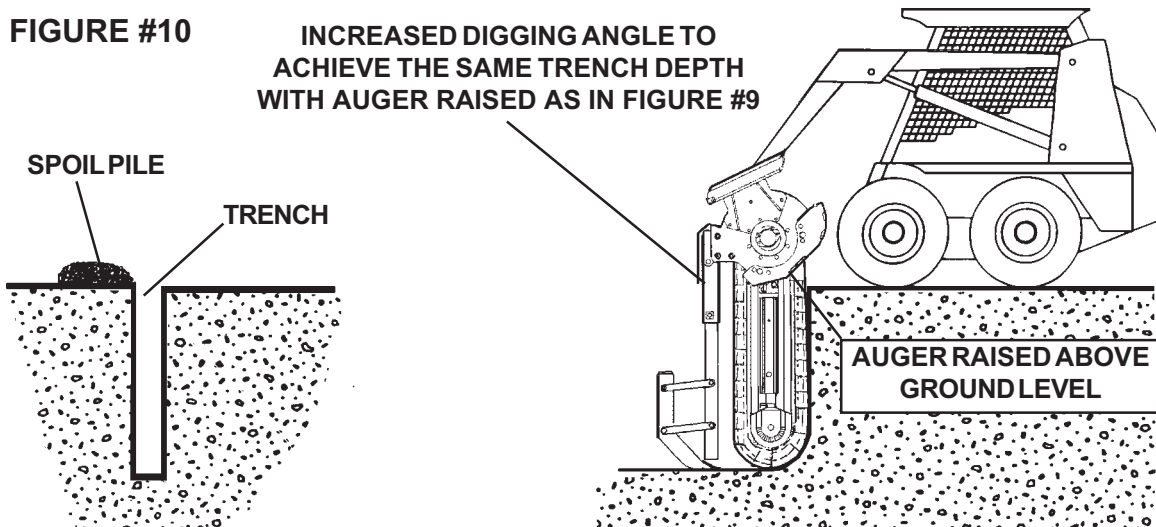

With the desired trench depth reached, advance the loader throttle to the desired engine RPM (we suggest full throttle for maximum digging power). Continue creeping the loader in reverse. Monitor the hydraulic oil pressure and temperature gauges as you trench. If hydraulic oil temperature or pressure gets too high, reduce loader creeping speed to reduce the load on the auxiliary hydraulic system.

IMPORTANT: Trying to trench at a speed faster than the auxiliary hydraulic system can handle could cause the trencher to stall. Continued stalling in a short period of time can cause excessive oil temperature, which can lead to pump failure. Do not try to trench too much too quickly. If oil temperature becomes too hot, stop the trencher and allow the oil to cool.

STALLING THE TRENCHER

If the trencher stalls while digging, move the loader forward slightly to free the trencher. You may be able to free up the digging chain by changing its direction of travel with the auxiliary hydraulic controls. Repeated stalling of the trencher will cause oil to overheat rapidly and should be avoided.

OPERATING INSTRUCTIONS

OPERATING TECHNIQUES 615 TRENCHERS

TURNING WHILE TRENCHING

Gradual turns can be made while trenching. However, the tightness of the turn is directly proportional to the angle and length of the boom. In other words, the greater the angle of the trencher boom to the ground level, the sharper the turn that can be trenched. (See Figures #11 & #12) Also the shorter the boom length, the sharper the possible turn. Remember, the greater the increase in boom angle, the higher the unit will have to be raised out of the trench to keep a unified trench depth. Shallow boom angles will severely limit turning ability.

IMPORTANT: Turning too tightly while trenching will cause the trencher to jam in the trench and stall, leading to excessive oil temperatures. Turning too tightly can also cause the trencher boom to bend. Take it easy when turning. Proceed slowly with caution.

FIGURE #11

TURNING WITH THE BOOM
AT A 90° DIGGING ANGLE

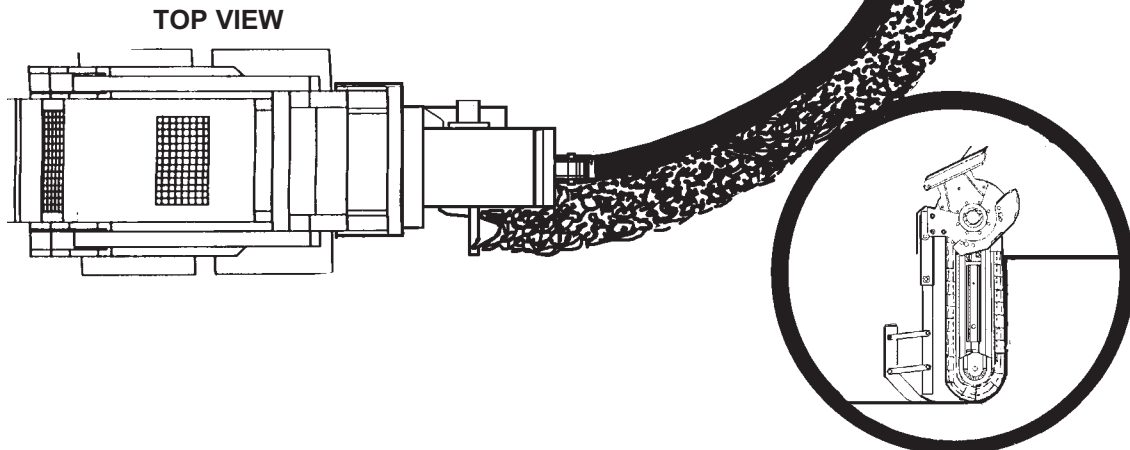
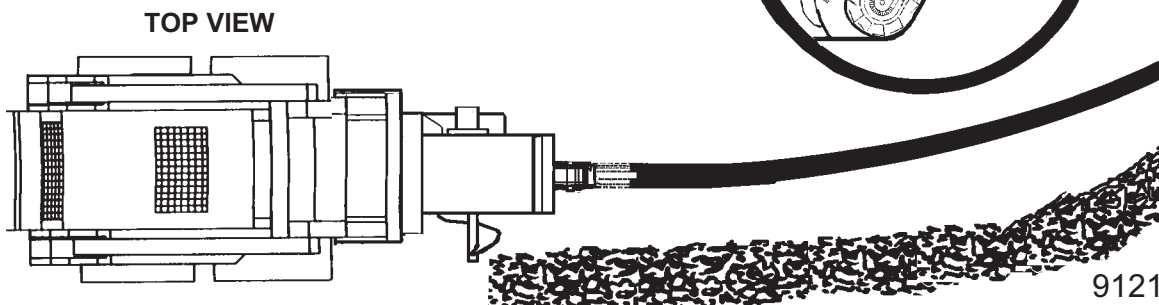

FIGURE #12

TURNING WITH THE BOOM AT
A 60° DIGGING ANGLE



OPERATING INSTRUCTIONS

OPERATING TECHNIQUES 615 TRENCHERS

MAKING SHARP TURNS

To make sharp turns and 90° angles, you will have to dig two trenches. Dig the first trench as you normally would. Then reposition the unit and dig the second trench at the appropriate angle. Be sure to take into account the extra lead-in space needed for the trencher to get down to the desired trench depth. (See Figure #13)

FIGURE #13

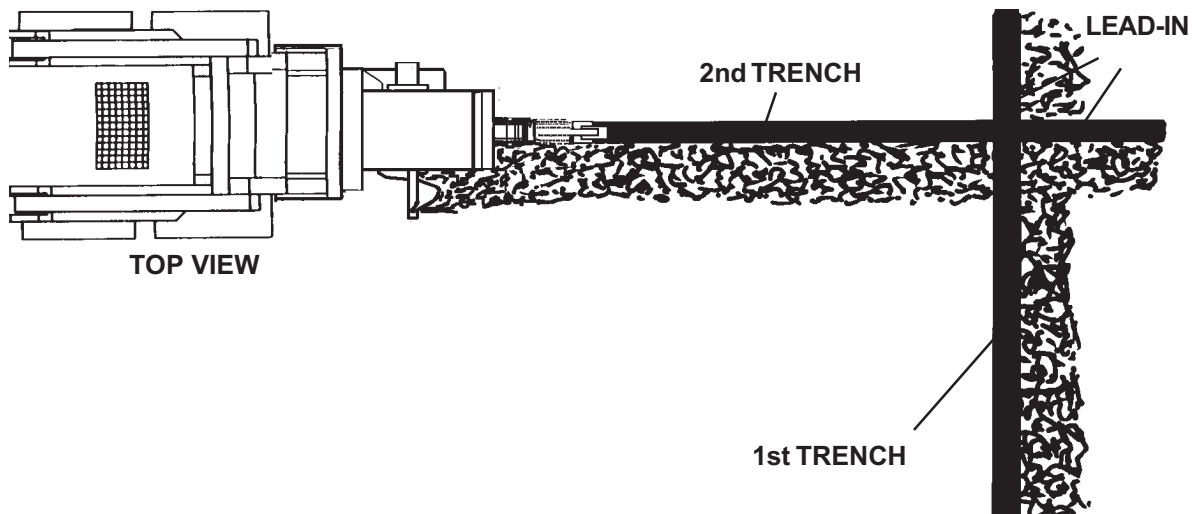

RECOMMENDED DIGGING ANGLES

A 90° digging angle is recommended for use in rock and frost conditions, and when trenching sharp corners. The 90° angle reduces excessive side pressure on the boom and digging chain when trenching corners. (See Figure #14)

A 60° - 65° digging angle is recommended for normal trenching. At this angle there will be less carry-over, and a cleaner trench bottom can be maintained than at a 90° angle. (See Figure #14)

FIGURE #14

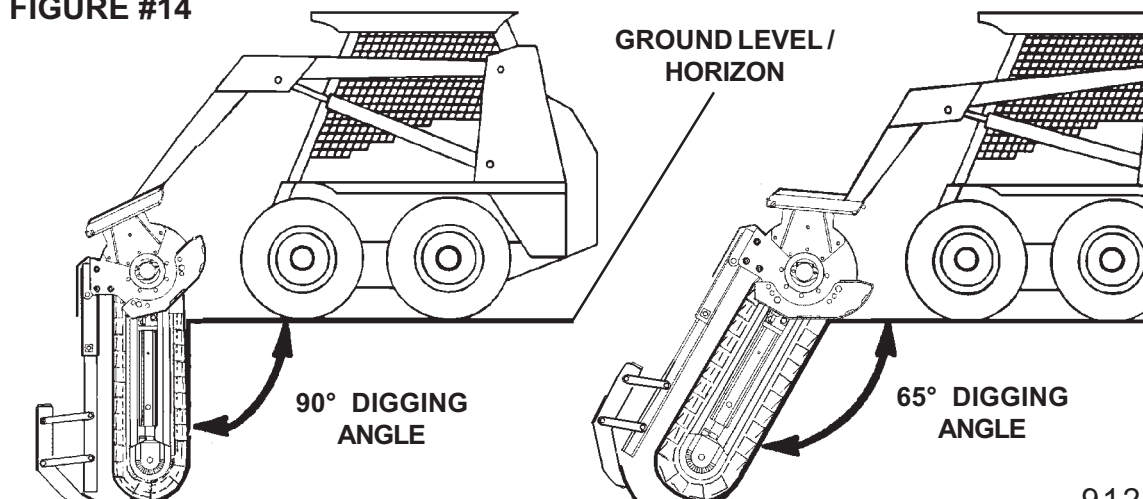

OPERATING INSTRUCTIONS

OPERATING TECHNIQUES 615 TRENCHERS

TRENCHING WITHOUT THE CRUMBER ASSEMBLY

WARNING! The crumber bar and crumber shoe assembly are there for a reason, YOUR SAFETY! There are a few instances where removal may be necessary, however. In these cases, operate with extreme caution. Reinstall the crumber bar and crumber shoe as soon as possible.



You can use your trencher to dig under obstacles such as sidewalks. To do so, remove the crumber shoe and bar assembly and start your trench as before within a foot of the sidewalk. With the crumber bar and shoe removed, you can start the trench vertically without any lead-in space.

When the desired depth has been reached, tilt the trencher at a 60° angle while digging, then creep the loader forward and trench under the sidewalk. Be careful not to contact the edge of the sidewalk with the digging teeth.

After you have gone as far as you can without contacting the sidewalk, drive the loader in reverse to clear the sidewalk and remove the trencher from the trench. Line up the unit on the other side of the walk and continue to trench as described above, until the two trenches are connected. (See Figure #15)

FIGURE #15

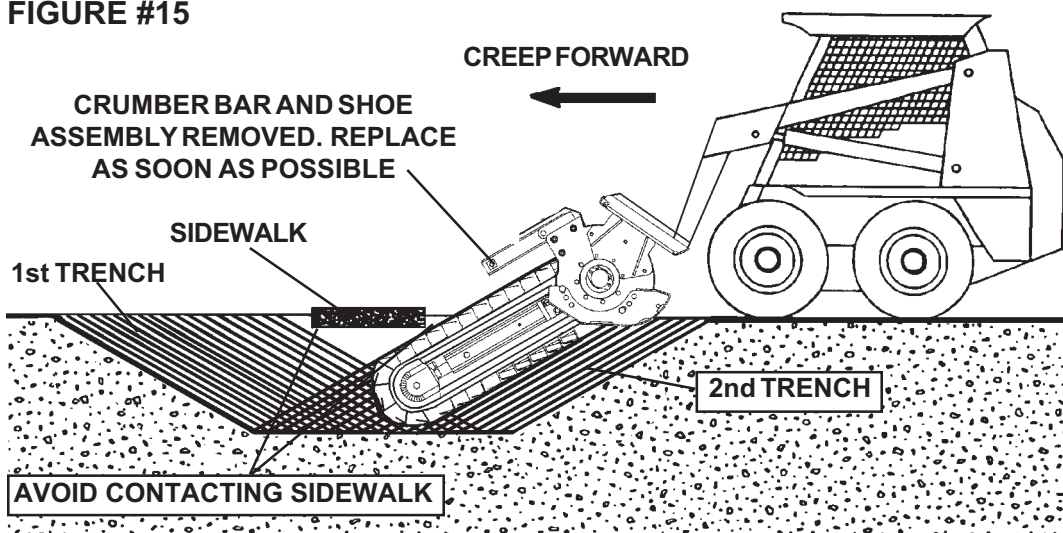

Reinstall the crumber bar and crumber shoe assembly immediately. Some spoil will be left in the trench, since the crumber was removed during the operation.

OPERATING INSTRUCTIONS

OPERATING TECHNIQUES 615 TRENCHERS

ENDING A TRENCH

When you have dug your trench, remember that the trencher boom is at an angle, and that you must continue trenching until the end of the boom has dug past the proposed end of the trench. Once the end of the trench has been dug, keep the trencher running and lift the loader arms to lift the unit clear of the trench. When the trencher has cleared the trench, disengage the auxiliary hydraulics to stop the trencher. Drive away from the trench.

TRANSPORTING THE TRENCHER

When transporting the trencher, remember to keep the trencher as low to the ground as is practical. The lower the trencher rides, the more stable the loader will be. You do not want the trencher so low that the digging teeth touch the ground in rough terrain. Shut off the trencher before moving it away from the trench. Never transport the trencher around the job site or anywhere else while the digging chain is moving.

TRENCHER PERFORMANCE

Remember that your trencher's performance is directly related to the power available at your loader's auxiliary hydraulic system. If the trencher seems to lack power or speed, it may be due to your loader's lack of sufficient auxiliary power.

Trencher performance is also related to how well it's maintained, digging tooth wear, and type and size of digging chain, crumber boom and shoe used. For more information on proper maintenance and chain wear see Section L. For information on chain, boom, and crumber options see Sections I and J. If problems arise see "Trouble Shooting" Section N.

615F FOOTING TRENCHER - SPECIAL APPLICATIONS

NOTE: When installing the footing trencher onto your unit, you MUST have a mount with side shift capabilities.

The 615F footing trencher is operated in the same manner as the 615 trencher with just a few points to be taken into consideration when digging a footing.

When digging a footing with the footing trencher, keep in mind the extra lead-in space needed for the trencher to get down to the desired depth. Set the inside forms in place and trench the footings before install the outside forms. (See Figure #16)

OPERATING INSTRUCTIONS

OPERATING TECHNIQUES 615 TRENCHERS

615F FOOTING TRENCHER - SPECIAL APPLICATIONS (Continued)

Check to ensure that the side shield is at the correct position for the width of chain being used and follow along the inside forms.

NOTE: When trenching with one of the wider chains (increasing the amount of spoil), it may be necessary to manually remove some of the spoil to prevent it from falling back into the trench.

NOTE: It is important when digging footings to keep the auger and side shield at ground level, but not below grade. This will give you good trencher performance, and still move the spoil out of the way for setting up the outside forms.

FIGURE #16

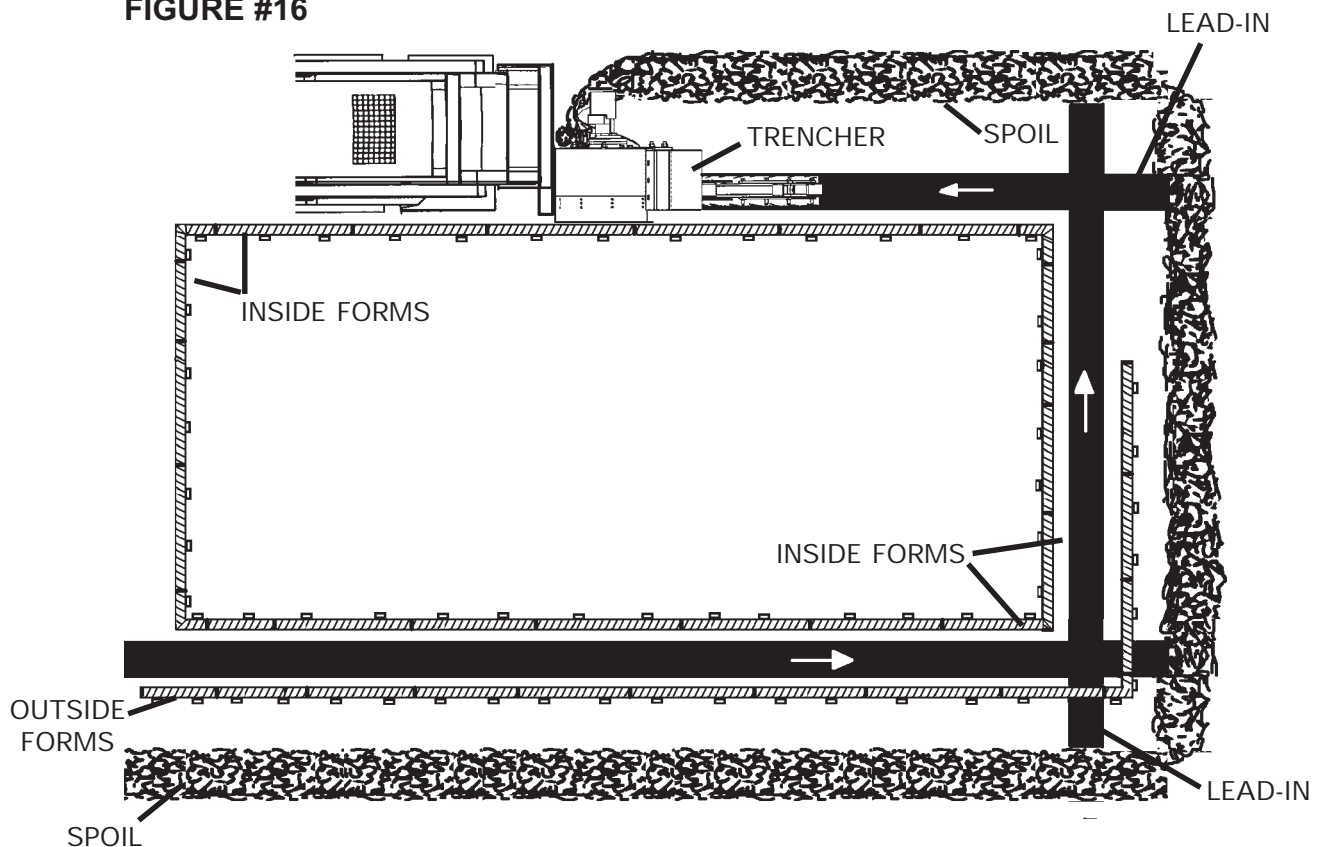

TRENCHER ASSEMBLY

615 TRENCHER ASSEMBLY

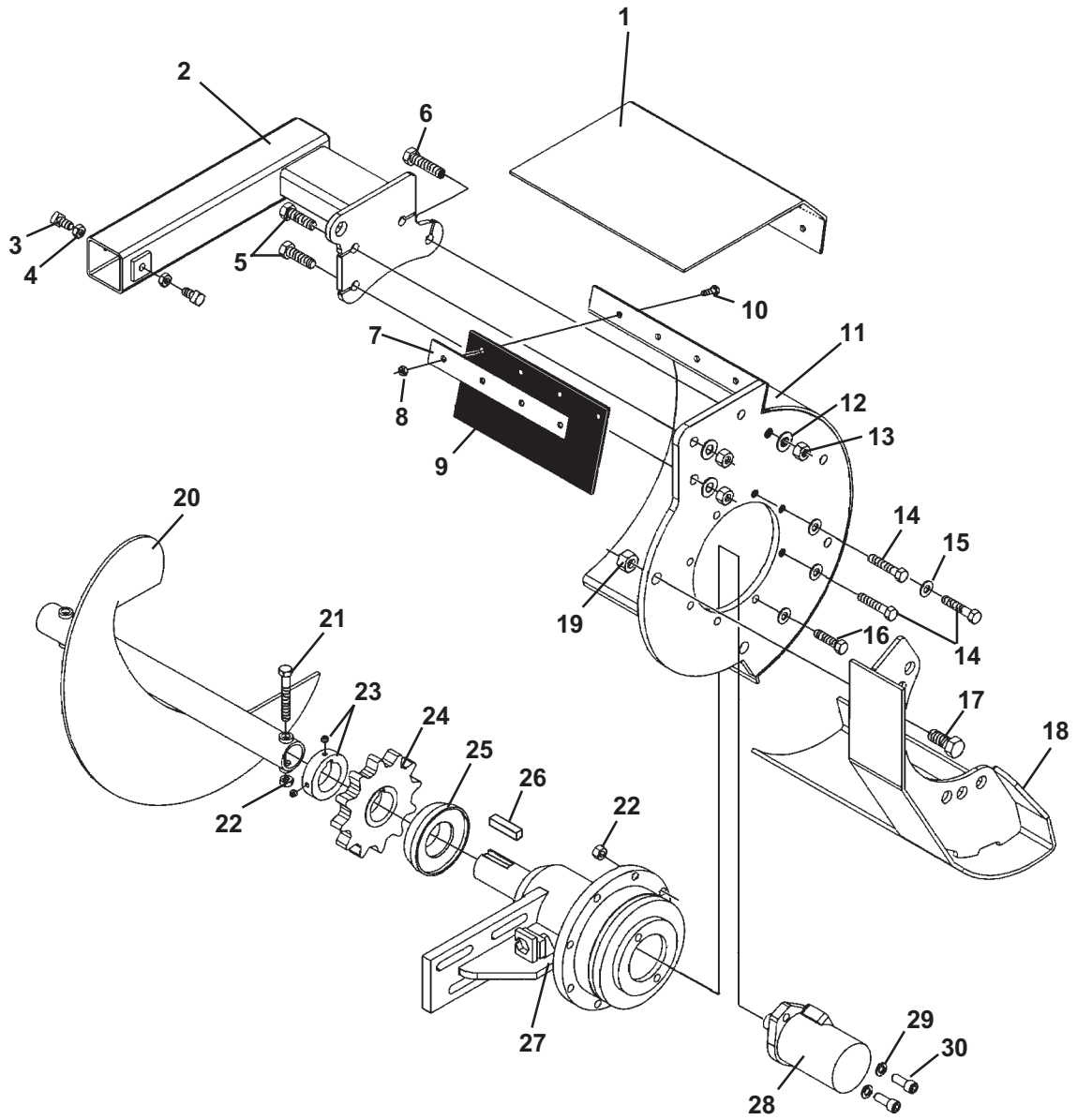

TRENCHER ASSEMBLY

615 TRENCHER ASSEMBLY

<u>NO</u>	<u>REQ'D</u>	<u>PART NO.</u>	<u>DESCRIPTION</u>
1	1	31300	Cover Plate
2	1	15806	Crumber Boom
3	2	1769	.50" UNC X 1.00" Square Head Set Screw
4	2	1242	.50" UNC Jam Nut
5	5	10070	.62" UNC X 1.75" Hex Capscrew - Grade 8
6	1	10071	.62" UNC X 2.25" Hex Capscrew - Grade 8
7	1	31660	Retaining Plate
8	4	1934	.31" UNC Deformed Lock Nut
9	1	31462	Rubber Flap
10	4	1023	.31" UNC X 1.25" Hex Capscrew
11	1	31383	Mainframe
12	6	1627	.62" Hard Flat Washer
13	6	1839	.62" UNC Deformed Lock Nut
14	3	1965	.50" UNC X 2.50" Hex Capscrew - Grade 8
15	8	1646	.50" Hard Flat Washer
16	5	1781	.50" UNC X 2.00" Hex Capscrew - Grade 8
17	2	1138	.75" UNC X 1.75" Hex Capscrew
18	1	31384	Skid Shoe
19	2	1936	.75" UNC Deformed Lock Nut
20	1	31398	Auger
21	1	1098	.50" UNC X 3.50" Hex Capscrew
22	9	1841	.50" UNC Deformed Lock Nut
23	-	31461	Replacement Locking Collar
	-	10028	Replacement Set Screw
24	-	31597	Replacement Sprocket
25	-	31399	Replacement Seal Protector
26	-	31400	Replacement Drive Sprocket Key
27	1	17039	Planetary Drive Assembly (Includes Items #23, #24, #25 & #26)
28	1	16695	Hydraulic Motor - (6-10 GPM Trencher)
	1	32407	Hydraulic Motor - (10-16 GPM Trencher)
	1	100813	Motor Gasket
29	2	1505	.50" Lock Washer
30	2	2714	.50" UNC X 1.50" Sockethead Capscrew (Used with Hydraulic Motor #32407)
	2	1907	.50" UNC X 1.25" Sockethead Capscrew (Used with Hydraulic Motor #16695)

9078

10-22-04-2

TRENCHER ASSEMBLY

24" BOOM AND CRUMBER
ASSEMBLY #18401

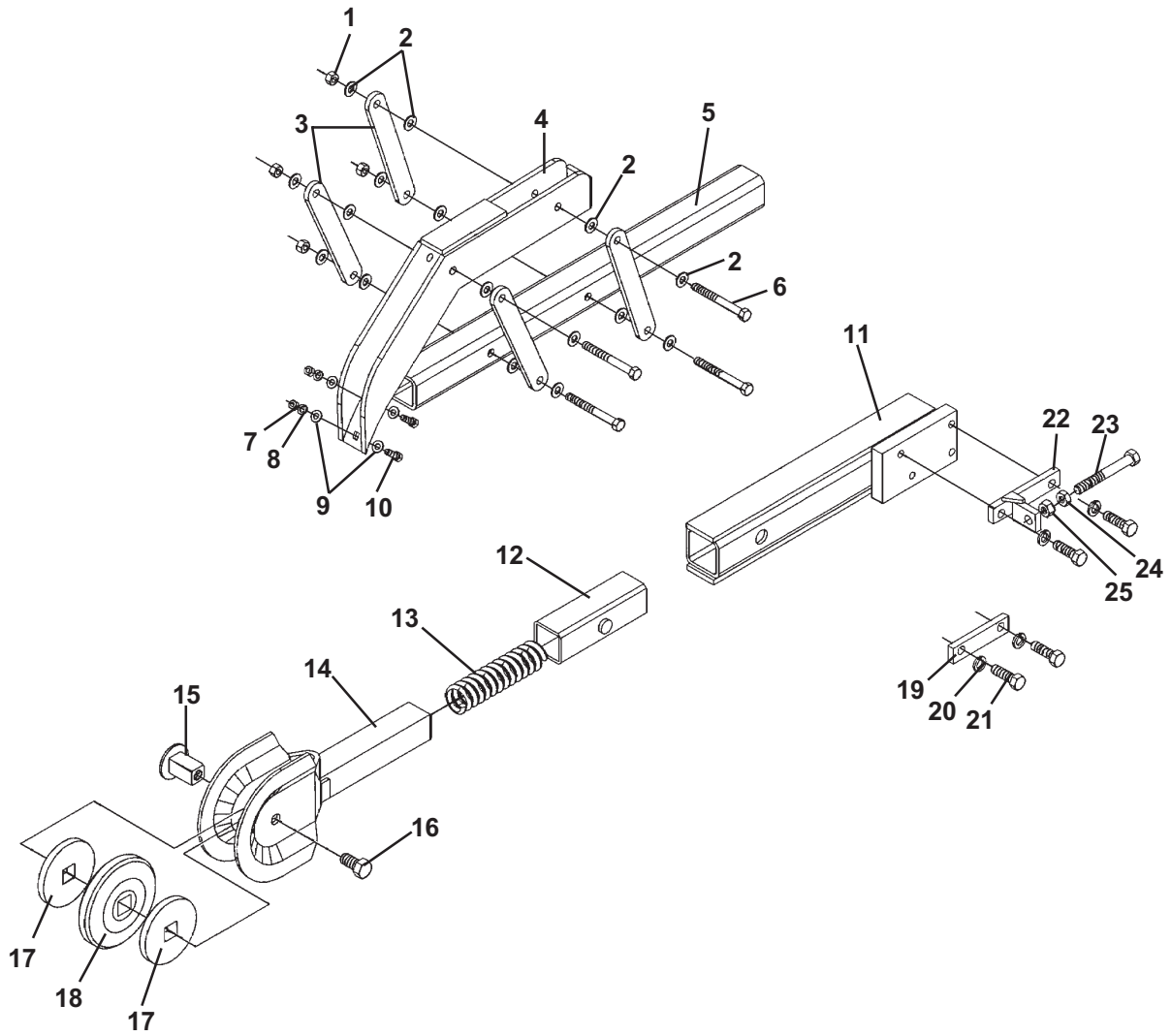

TRENCHER ASSEMBLY

24" BOOM AND CRUMBER
ASSEMBLY #18401

<u>NO</u>	<u>REQ'D</u>	<u>PART NO.</u>	<u>DESCRIPTION</u>
1	4	1841	.50" UNC Deformed Lock Nut - Grade 8
2	16	1646	.50" Hard Flat Washer
3	4	21061	Lever Arm
4	1	89278	Crumber End
5	1	89276	Crumber Bar / Personal Restraint Bar
6	4	1101	.50" UNC X 4.50" Hex Capscrew
7	2	1226	.38" UNC Hex Nut
8	2	1503	.38" Lock Washer
9	4	1514	.38" Flat Washer
10	2	1044	.38" UNC X 1.25" Hex Capscrew
11	1	18468	24" Boom
12	1	53138	Boom Bushing
13	1	53188	Spring
14	1	62717	Boom End
15	1	17136	Square Pin
16	1	1548	.75" UNC X 1.25" Nylock Capscrew
17	2	18091*	Idler Spacer
18	1	53988*	Idler Bearing Hub
	1	62718*	Idler Wheel
	1	8085*	Idler Bearing
19	1	18107	Plate
20	4	1506	.62" Lock Washer
21	4	1895	.62" UNC X 2.00" Hex Capscrew - Grade 8
22	1	17518	Adjustment Bracket
23	1	18105	.62" UNC X 4.00" Hex Capscrew - Grade 8
24	1	1244	.62" UNC Jam Nut
25	1	1230	.62" UNC Hex Nut

NOTE: Idler Roller Assembly Repair Kit #18725 includes all parts marked with an asterisk (*).

TRENCHER ASSEMBLY

30" BOOM AND CRUMBER
ASSEMBLY #18402

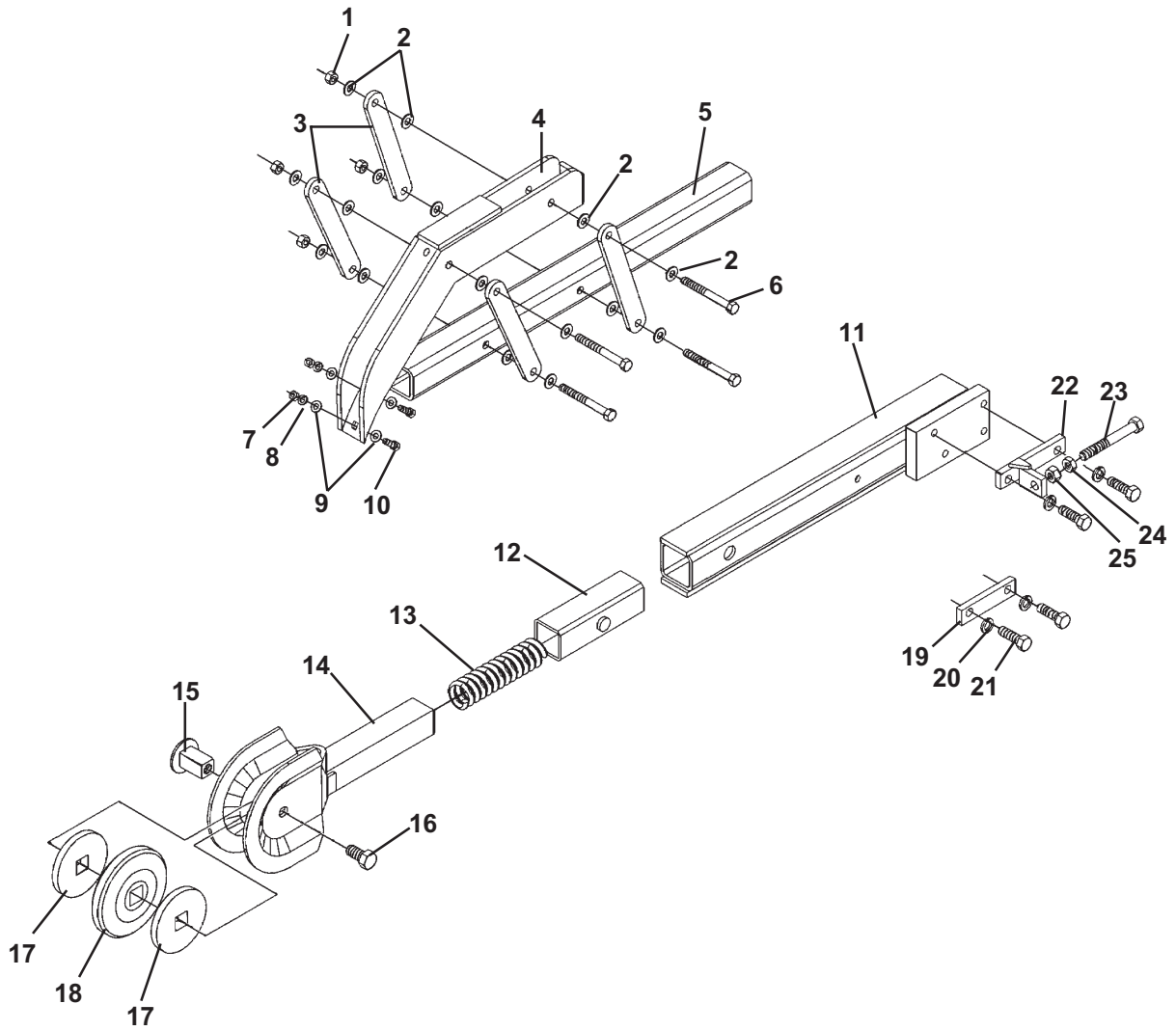

TRENCHER ASSEMBLY

30" BOOM AND CRUMBER
ASSEMBLY #18402

<u>NO</u>	<u>REQ'D</u>	<u>PART NO.</u>	<u>DESCRIPTION</u>
1	4	1841	.50" UNC Deformed Lock Nut - Grade 8
2	16	1646	.50" Hard Flat Washer
3	4	21061	Lever Arm
4	1	89278	Crumber End
5	1	89276	Crumber Bar / Personal Restraint Bar
6	4	1101	.50" UNC X 4.50" Hex Capscrew
7	2	1226	.38" UNC Hex Nut
8	2	1503	.38" Lock Washer
9	4	1514	.38" Flat Washer
10	2	1044	.38" UNC X 1.25" Hex Capscrew
11	1	18469	30" Boom
12	1	53138	Boom Bushing
13	1	53188	Spring
14	1	62717	Boom End
15	1	17136	Square Pin
16	1	1548	.75" UNC X 1.25" Nylock Capscrew
17	2	18091*	Idler Spacer
18	1	53988*	Idler Bearing Hub
	1	62718*	Idler Wheel
	1	8085*	Idler Bearing
19	1	18107	Plate
20	4	1506	.62" Lock Washer
21	4	1895	.62" UNC X 2.00" Hex Capscrew - Grade 8
22	1	17518	Adjustment Bracket
23	1	18105	.62" UNC X 4.00" Hex Capscrew - Grade 8
24	1	1244	.62" UNC Jam Nut
25	1	1230	.62" UNC Hex Nut

NOTE: Idler Roller Assembly Repair Kit #18725 includes all parts marked with an asterisk (*).

TRENCHER ASSEMBLY

36" BOOM AND CRUMBER
ASSEMBLY #18403

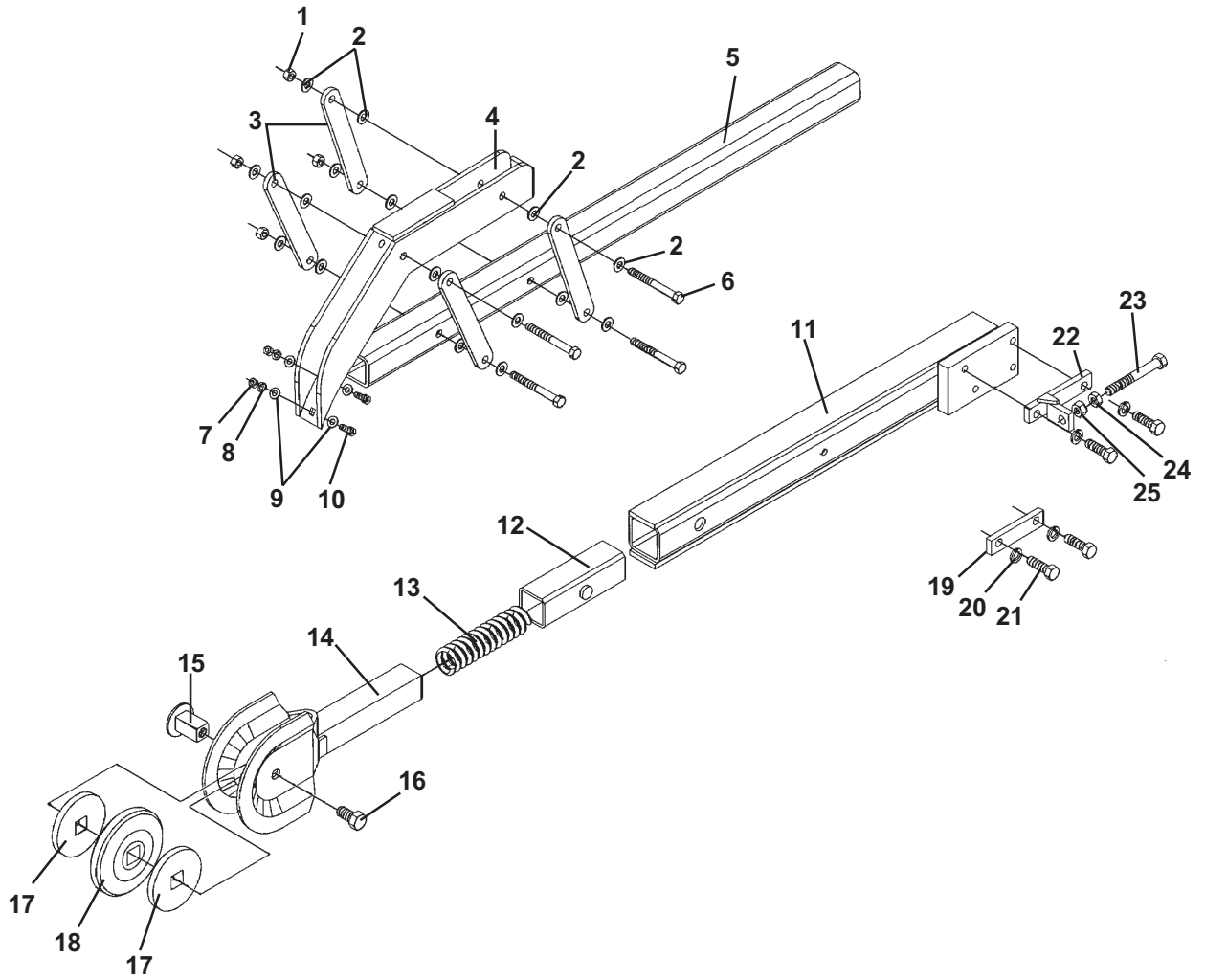

TRENCHER ASSEMBLY

36" BOOM AND CRUMBER
ASSEMBLY #18403

<u>NO</u>	<u>REQ'D</u>	<u>PART NO.</u>	<u>DESCRIPTION</u>
1	4	1841	.50" UNC Deformed Lock Nut - Grade 8
2	16	1646	.50" Hard Flat Washer
3	4	21061	Lever Arm
4	1	89278	Crumber End
5	1	21045	Crumber Bar / Personal Restraint Bar
6	4	1101	.50" UNC X 4.50" Hex Capscrew
7	2	1226	.38" UNC Hex Nut
8	2	1503	.38" Lock Washer
9	4	1514	.38" Flat Washer
10	2	1044	.38" UNC X 1.25" Hex Capscrew
11	1	18470	36" Boom
12	1	53138	Boom Bushing
13	1	53188	Spring
14	1	62717	Boom End
15	1	17136	Square Pin
16	1	1548	.75" UNC X 1.25" Nylock Capscrew
17	2	18091*	Idler Spacer
18	1	53988*	Idler Bearing Hub
	1	62718*	Idler Wheel
	1	8085*	Idler Bearing
19	1	18107	Plate
20	4	1506	.62" Lock Washer
21	4	1895	.62" UNC X 2.00" Hex Capscrew - Grade 8
22	1	17518	Adjustment Bracket
23	1	18105	.62" UNC X 4.00" Hex Capscrew - Grade 8
24	1	1244	.62" UNC Jam Nut
25	1	1230	.62" UNC Hex Nut

NOTE: Idler Roller Assembly Repair Kit #18725 includes all parts marked with an asterisk (*).

TRENCHER ASSEMBLY

48" BOOM AND CRUMBER
ASSEMBLY #18404

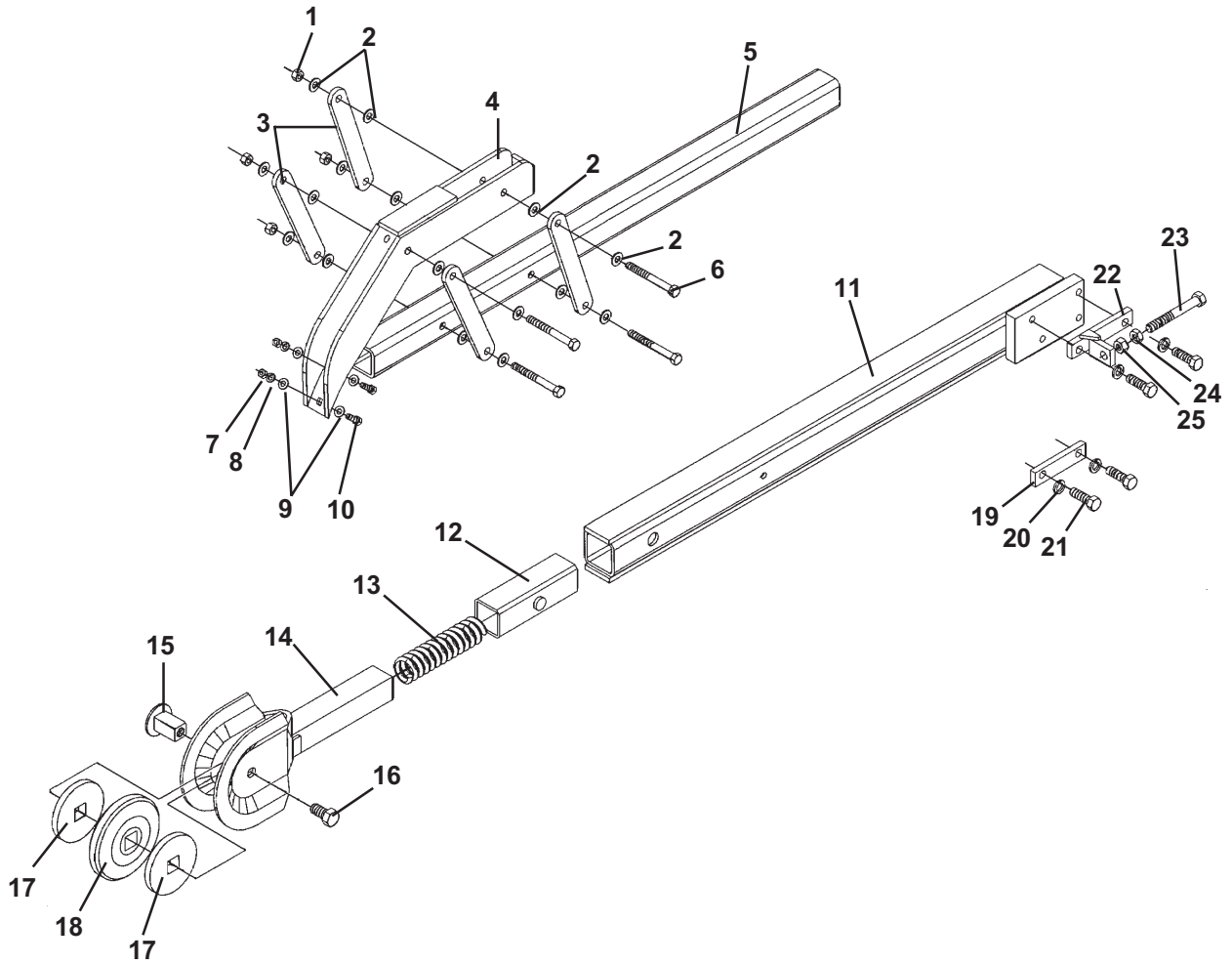

TRENCHER ASSEMBLY

48" BOOM AND CRUMBER
ASSEMBLY #18404

<u>NO</u>	<u>REQ'D</u>	<u>PART NO.</u>	<u>DESCRIPTION</u>
1	4	1841	.50" UNC Deformed Lock Nut - Grade 8
2	16	1646	.50" Hard Flat Washer
3	4	21061	Lever Arm
4	1	89278	Crumber End
5	1	21046	Crumber Bar / Personal Restraint Bar
6	4	1101	.50" UNC X 4.50" Hex Capscrew
7	2	1226	.38" UNC Hex Nut
8	2	1503	.38" Lock Washer
9	4	1514	.38" Flat Washer
10	2	1044	.38" UNC X 1.25" Hex Capscrew
11	1	18471	48" Boom
12	1	53138	Boom Bushing
13	1	53188	Spring
14	1	62717	Boom End
15	1	17136	Square Pin
16	1	1548	.75" UNC X 1.25" Nylock Capscrew
17	2	18091*	Idler Spacer
18	1	53988*	Idler Bearing Hub
	1	62718*	Idler Wheel
	1	8085*	Idler Bearing
19	1	18107	Plate
20	4	1506	.62" Lock Washer
21	4	1895	.62" UNC X 2.00" Hex Capscrew - Grade 8
22	1	17518	Adjustment Bracket
23	1	18105	.62" UNC X 4.00" Hex Capscrew - Grade 8
24	1	1244	.62" UNC Jam Nut
25	1	1230	.62" UNC Hex Nut

NOTE: Idler Roller Assembly Repair Kit #18725 includes all parts marked with an asterisk (*).

TRENCHER ASSEMBLY

615F (FOOTING) TRENCHER ASSEMBLY

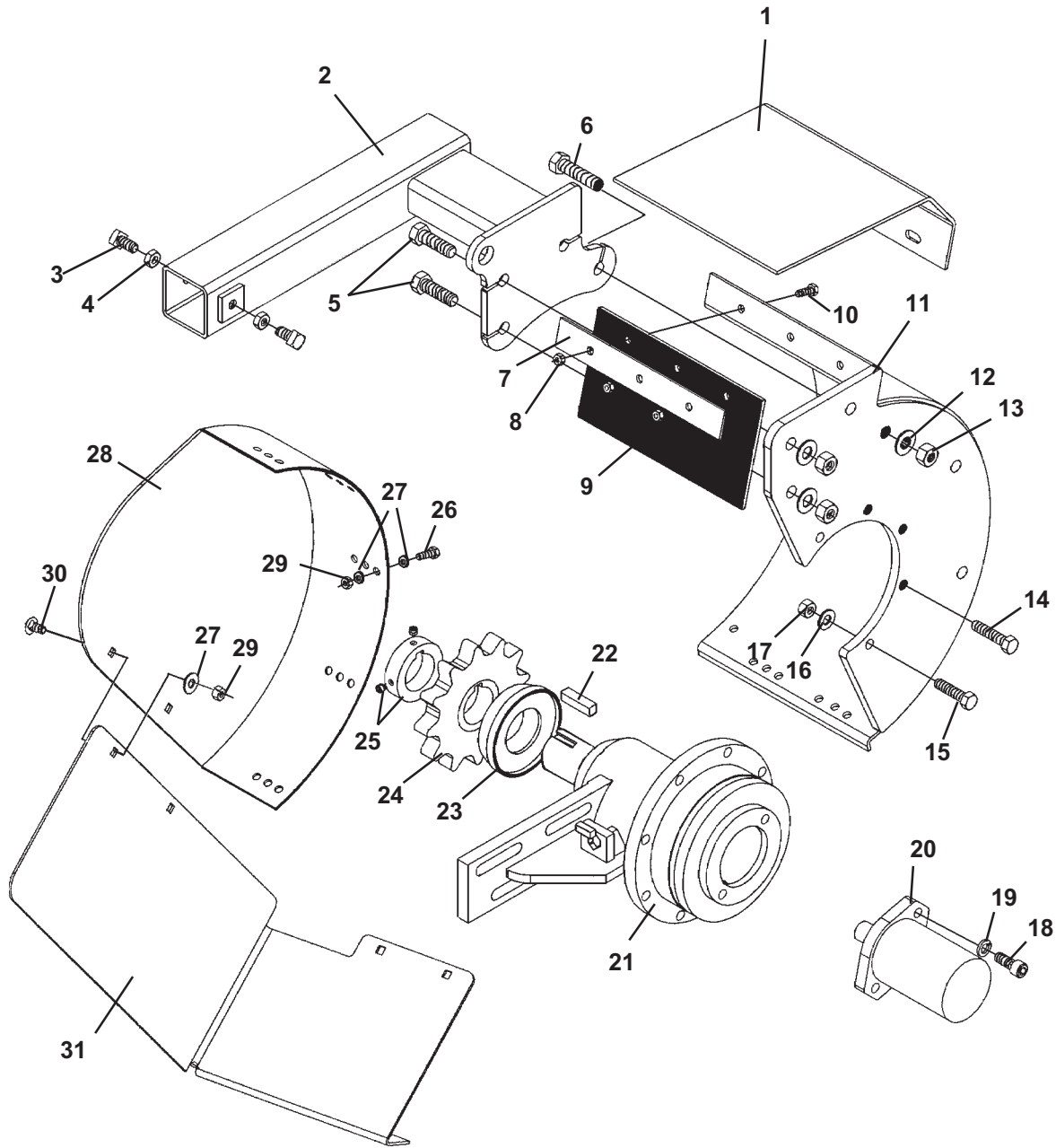

TRENCHER ASSEMBLY

615F (FOOTING) TRENCHER ASSEMBLY

<u>NO</u>	<u>REQ'D</u>	<u>PART NO.</u>	<u>DESCRIPTION</u>
1	1	31300	Cover Plate
2	1	15806	Crumber Boom
3	2	1769	.50" UNC X 1.00" Square Head Set Screw
4	2	1242	.50" UNC Jam Nut
5	5	10070	.62" UNC X 1.75" Hex Capscrew - Grade 8
6	1	10071	.62" UNC X 2.25" Hex Capscrew - Grade 8
7	1	18143	Retaining Plate
8	3	1934	.31" UNC Deformed Lock Nut
9	1	18142	Rubber Flap
10	3	1023	.31" UNC X 1.25" Hex Capscrew
11	1	17471	Mainframe
12	6	1627	.62" Hard Flat Washer
13	6	1839	.62" UNC Deformed Lock Nut
14	3	1965	.50" UNC X 2.50" Hex Capscrew - Grade 8
15	2	1781	.50" UNC X 2.00" Hex Capscrew - Grade 8
16	5	1646	.50" Hard Flat Washer
17	5	1841	.50" UNC Deformed Lock Nut
18	2	2714	.50" UNC X 1.50" Sockethead Capscrew (Used with Hydraulic Motor #32407)
	2	1907	.50" UNC X 1.25" Sockethead Capscrew (Used with Hydraulic Motor #16695)
19	2	1505	.50" Lock Washer
20	1	16695	Hydraulic Motor (6-10 GPM Trencher)
	1	32407	Hydraulic Motor (10-16 GPM Trencher)
	1	100813	Motor Gasket
21	1	17039	Planetary Drive Assembly (Includes Items #22, #23, #24 & #25)
22	-	31400	Replacement Kit
23	-	31399	Replacement Seal Protector
24	-	31597	Replacement Drive Sprocket
25	-	31461	Replacement Locking Collar
	-	10028	Replacement Set Screw
26	4	1042	.38" UNC X .75" Hex Capscrew GR 5
27	12	1514	.38" Flat Washer
28	1	18131	Chain Guard
29	8	1837	.38" UNC Deformed Lock Nut
30	4	10075	.38" UNC X .75" Carriage Bolt
31	1	19112	Footing Guard

TRENCHER ASSEMBLY

24" BOOM AND CRUMBER ASSEMBLY #18121
(FOR 615F FOOTING TRENCHER ONLY)

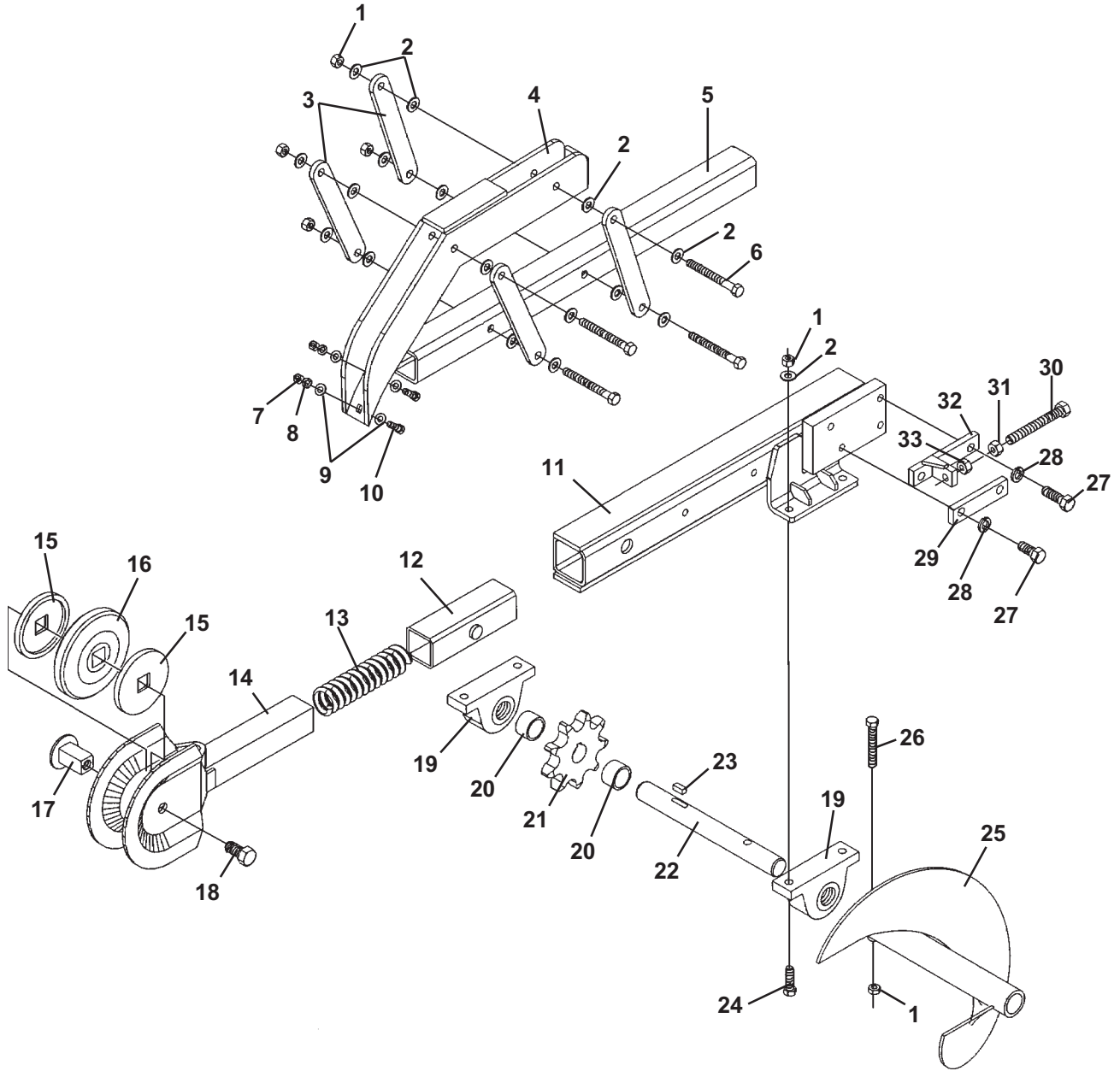

TRENCHER ASSEMBLY

24" BOOM AND CRUMBER ASSEMBLY #18121
(FOR 615F FOOTING TRENCHER ONLY)

<u>NO</u>	<u>REQ'D</u>	<u>PART NO.</u>	<u>DESCRIPTION</u>
1	9	1841	.50" UNC Deformed Lock Nut
2	20	1646	.50" Hard Flat Washer
3	4	21061	Lever Arm
4	1	89278	Crumber End
5	1	21045	Crumber Bar / Personal Restraint Bar
6	4	1101	.50" UNC X 4.50" Hex Capscrew
7	2	1226	.38" UNC Hex Nut
8	2	1503	.38" Lock Washer
9	4	1514	.38" Flat Washer
10	2	1044	.38" UNC X 1.25" Hex Capscrew
11	1	18103	Boom
12	1	53138	Boom Bushing
13	1	53188	Spring
14	1	62717	Boom End
15	2	18091*	Idler Spacer
16	1	53988*	Idler Bearing Hub
	1	62718*	Idler Wheel
	1	8085*	Idler Bearing
17	1	17136	Square Pin
18	1	1548	.75" UNC X 1.25" Hex Capscrew
19	2	17483	Pillow Block Bearing
20	2	17485	Spacer
21	1	17484	Sprocket
22	1	17482	Auger Shaft
23	1	18706	Key
24	4	1091	.50" UNC X 1.75" Hex Capscrew
25	1	17479	Auger
26	1	1818	.50" UNC X 2.75" Hex Capscrew - Grade 8
27	4	1895	.62" UNC X 2.00" Hex Capscrew - Grade 8
28	4	1506	.62" Lock Washer
29	1	18107	Plate
30	1	18105	.62" UNC X 4.00" Hex Capscrew - Grade 8
31	1	1244	.62" UNC Jam Nut
32	1	17518	Adjustment Bracket
33	1	1230	.62" UNC Hex Nut

NOTE: Idler Roller Assembly Repair Kit #18725 includes all parts marked with an asterisk (*).

TRENCHER ASSEMBLY

30" BOOM AND CRUMBER ASSEMBLY #18120
(FOR 615F FOOTING TRENCHER ONLY)

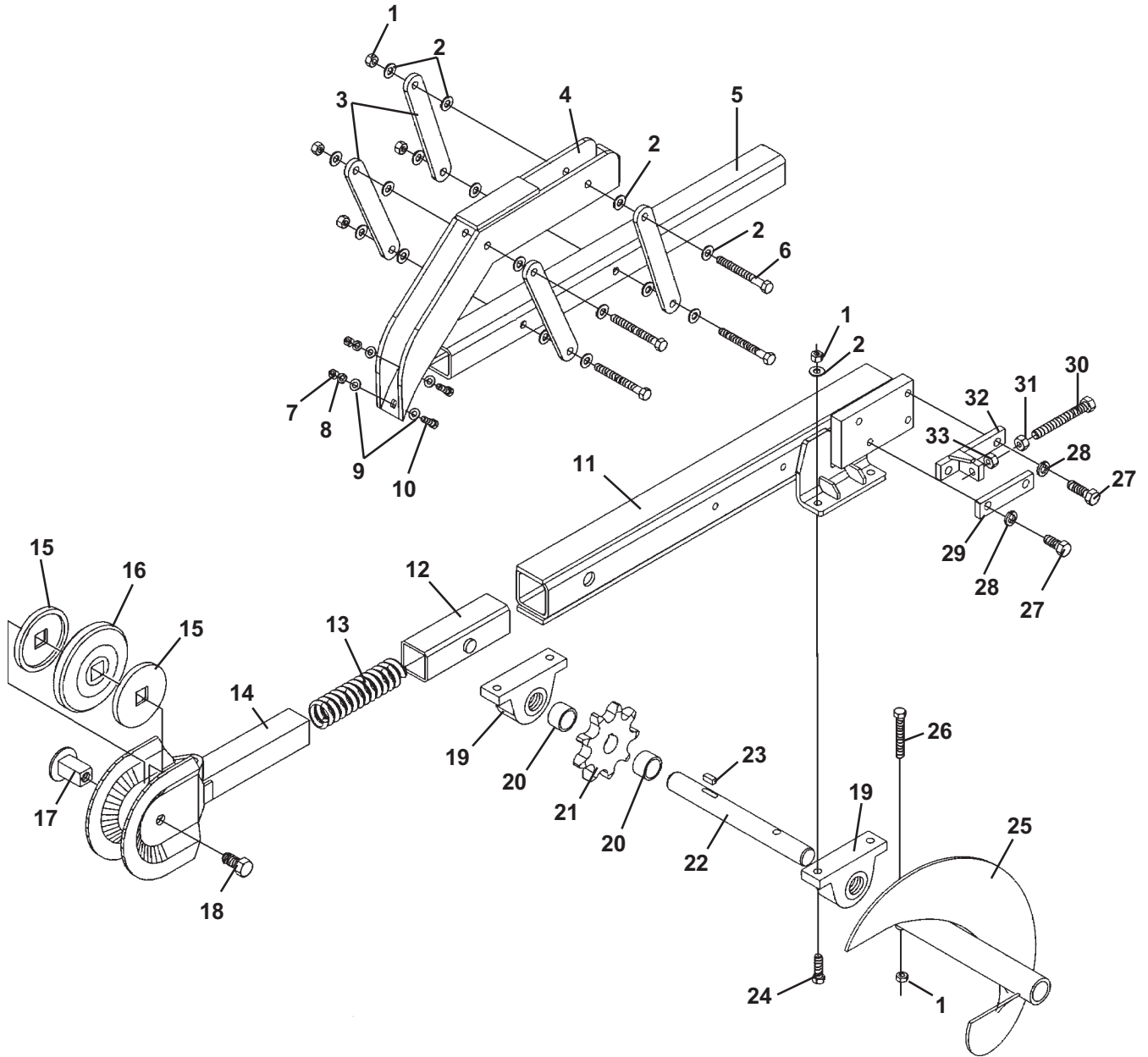

TRENCHER ASSEMBLY

30" BOOM AND CRUMBER ASSEMBLY #18120
(FOR 615F FOOTING TRENCHER ONLY)

<u>NO</u>	<u>REQ'D</u>	<u>PART NO.</u>	<u>DESCRIPTION</u>
1	9	1841	.50" UNC Deformed Lock Nut
2	20	1646	.50" Hard Flat Washer
3	4	21061	Lever Arm
4	1	89278	Crumber End
5	1	21045	Crumber Bar / Personal Restraint Bar
6	4	1101	.50" UNC X 4.50" Hex Capscrew
7	2	1226	.38" UNC Hex Nut
8	2	1503	.38" Lock Washer
9	4	1514	.38" Flat Washer
10	2	1044	.38" UNC X 1.25" Hex Capscrew
11	1	18087	Boom
12	1	53138	Boom Bushing
13	1	53188	Spring
14	1	62717	Boom End
15	2	18091*	Idler Spacer
16	1	53988*	Idler Bearing Hub
	1	62718*	Idler Wheel
	1	8085*	Idler Bearing
17	1	17136	Square Pin
18	1	1548	.75" UNC X 1.25" Hex Capscrew
19	2	17483	Pillow Block Bearing
20	2	17485	Spacer
21	1	17484	Sprocket
22	1	17482	Auger Shaft
23	1	18706	Key
24	4	1091	.50" UNC X 1.75" Hex Capscrew
25	1	17479	Auger
26	1	1818	.50" UNC X 2.75" Hex Capscrew - Grade 8
27	4	1895	.62" UNC X 2.00" Hex Capscrew - Grade 8
28	4	1506	.62" Lock Washer
29	1	18107	Plate
30	1	18105	.62" UNC X 4.00" Hex Capscrew - Grade 8
31	1	1244	.62" UNC Jam Nut
32	1	17518	Adjustment Bracket
33	1	1230	.62" UNC Hex Nut

NOTE: Idler Roller Assembly Repair Kit #18725 includes all parts marked with an asterisk (*).

DIGGING CHAIN OPTIONS

GENERAL INFORMATION

This section is devoted to digging chain options for your trencher. In it you will find a listing of all the chain options available. You will also find information on replacement parts, chain assembly, and chain conversion. These options will increase the flexibility of your equipment, and make your trenching job easier.

There is some basic information about the trencher and its digging components that you should know before you try to order any options. This information is given here for your convenience. With it you will be able to better understand the rest of this section.

CHAIN PITCH

The digging chains may be divided into groups by pitch. The pitch of the chain is the distance between the centers of the holes in the chain links (See Figure 1). The word pitch can also be used to describe the length of the chain.

FIGURE #1

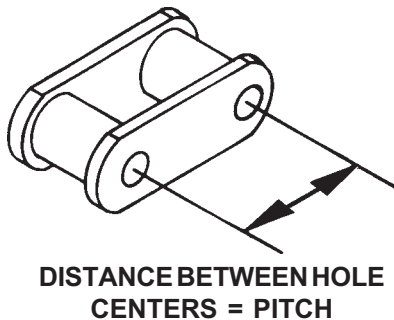
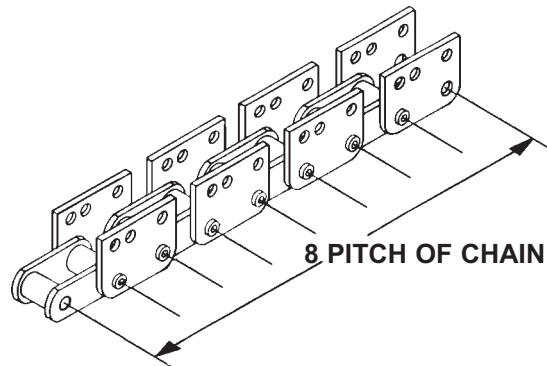

FIGURE #2



The 615 Trencher has a heavy weight chain with a tensile strength of 38,000 pounds and a pitch of 1.654".

There is one thing that you must understand about chain pitch. You can not intermix components of different pitches. You cannot substitute chain links of different pitches in a digging chain. Nor can you use a digging chain of one pitch, with a driver sprocket of a different pitch. Attempting to do so will cause the chain to "jump" off the sprocket continuously.

DIGGING CHAIN OPTIONS

COMPONENT SIZE

The size of the digging component is based on the depth of the trench it will dig with auger at ground level and a 60° boom digging angle (See Figure 3). For example, a 36" boom is not necessarily 36" long. The 36" length means it will dig a trench 36" deep with the augers in their float position and at a 60° digging angle.

FIGURE #3

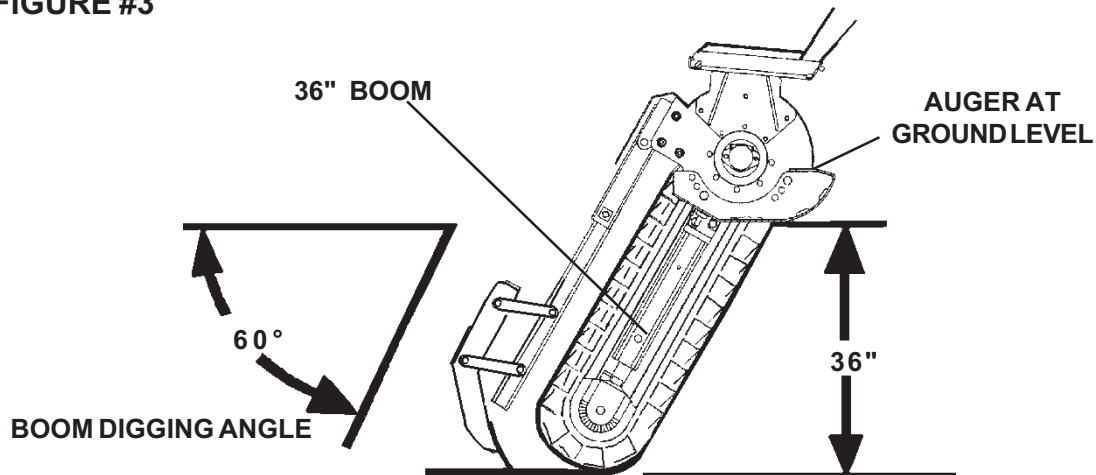

DIGGING STATIONS

Digging chains are made up of a series of individual links pinned together. Every link has a special "Digging Station" link. These links are designed so that the digging teeth can be attached to the basic chains (See Figure 4). Digging chains may be purchased in any length, with or without teeth. All chains, teeth, spacers and assorted digging hardware may be purchased separately.

FIGURE #4

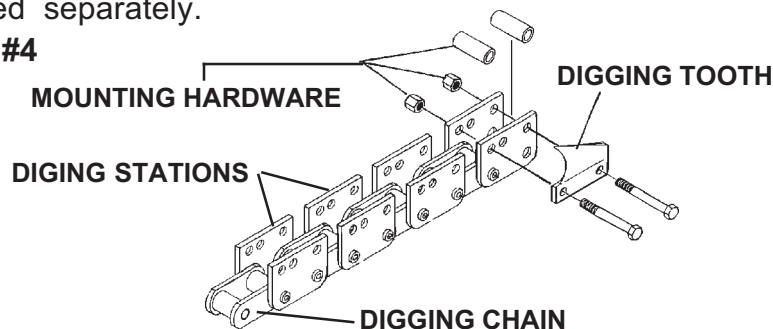

This completes the basic information on digging chain options. The rest of this section contains specific information on digging chains and parts available, complete with part numbers. Again it may be noted that these options are designed to increase the flexibility of your equipment and to make your trenching jobs easier. We offer them to better serve your trenching needs.

DIGGING CHAIN OPTIONS

1.654" PITCH DIGGING CHAIN ASSEMBLIES

GENERAL INFORMATION

This page contains a listing of all of the 1.654" pitch digging chain assemblies offered for your trencher. Each chain assembly comes with all necessary teeth and spacers already installed. Just thread the chain onto the trencher and fasten the two ends together with the pin and keeper pin included in the assembly. A crumber shoe of the appropriate width is also included in the chain assembly.

Before you order a new chain, be sure to check for compatibility with corresponding components. You may need to order more than just a chain assembly. You must use a digging boom of the same digging depth as the chain. The crumber bar must also be of the same digging depth. The digging sprocket must also be of the same pitch as the chain. All of these components must match for the trencher to function properly.

Bare 1.654" pitch digging chain (without teeth, spacers, or hardware) can be ordered in any desired length under the part number #17015. Just use this number and then specify the length desired in pitches (example, 64 pitches of chain would be needed for a 615 with a 36" boom).

1.654" PITCH CUP TOOTH DIGGING CHAIN ASSEMBLIES				
Complete chain assemblies. Includes chain with all teeth and spacers attached. Also includes appropriate width crumber shoe.				
615 TRENCHER CHAIN ASSEMBLIES WITH A TOOTH EVERY STATION				
DESCRIPTION (boom used X trench width)		LENGTH OF CHAIN (in 1.654" pitches)	TENSIL STRENGTH	PART NO.
For 24" Boom	6" Wide	50 Pitch	38,000#	16691
For 24" Boom	8" Wide	50 Pitch	38,000#	16690
For 24" Boom	10" Wide	50 Pitch	38,000#	16689
For 24" Boom	12" Wide	50 Pitch	38,000#	16688
For 30" Boom	6" Wide	58 Pitch	38,000#	16686
For 30" Boom	8" Wide	58 Pitch	38,000#	16685
For 30" Boom	10" Wide	58 Pitch	38,000#	16684
For 36" Boom	4.5" Wide	64 Pitch	38,000#	89822
For 36" Boom	6" Wide	64 Pitch	38,000#	89823
For 36" Boom	8" Wide	64 Pitch	38,000#	89824
For 48" Boom	4.5" Wide	82 Pitch	38,000#	18772
For 48" Boom	6" Wide	82 Pitch	38,000#	18773

DIGGING CHAIN OPTIONS

1.654" PITCH DIGGING CHAIN ASSEMBLIES

1.654" PITCH CUP TOOTH DIGGING CHAIN ASSEMBLIES				
Complete chain assemblies. Includes chain with all teeth and spacers attached. Also includes appropriate width crumber shoe.				
615F TRENCHER CHAIN ASSEMBLIES WITH A TOOTH EVERY STATION				
DESCRIPTION (boom used X trench width)		LENGTH OF CHAIN (in 1.654" pitches)	TENSIL STRENGTH	PART NO.
For 24" Boom	6" Wide	64 Pitch	38,000#	89823
For 24" Boom	8" Wide	64 Pitch	38,000#	89824
For 24" Boom	10" Wide	64 Pitch	38,000#	16681
For 24" Boom	12" Wide	64 Pitch	38,000#	16682
For 30" Boom	6" Wide	72 Pitch	38,000#	18909
For 30" Boom	8" Wide	72 Pitch	38,000#	18774
For 30" Boom	10" Wide	72 Pitch	38,000#	18775
NOTE: THESE CHAIN ASSEMBLIES ARE FOR THE FOOTING TRENCHER ONLY!				

1.654" PITCH 70/30 COMBINATION DIGGING CHAIN ASSEMBLIES				
Complete chain assemblies. Includes chain with all teeth and spacers attached. Also includes appropriate width crumber shoe.				
615 TRENCHER CHAIN ASSEMBLIES WITH A TOOTH EVERY STATION				
DESCRIPTION (boom used X trench width)		LENGTH OF CHAIN (in 1.654" pitches)	TENSIL STRENGTH	PART NO.
For 24" Boom	6" Wide	50 Pitch	38,000#	18763
For 24" Boom	8" Wide	50 Pitch	38,000#	18764
For 24" Boom	10" Wide	50 Pitch	38,000#	18765
For 24" Boom	12" Wide	50 Pitch	38,000#	18766
For 30" Boom	6" Wide	58 Pitch	38,000#	18767
For 30" Boom	8" Wide	58 Pitch	38,000#	18768
For 30" Boom	10" Wide	58 Pitch	38,000#	18769
For 36" Boom	4.5" Wide	64 Pitch	38,000#	89825
For 36" Boom	6" Wide	64 Pitch	38,000#	89826
For 36" Boom	8" Wide	64 Pitch	38,000#	89827
For 48" Boom	4.5" Wide	82 Pitch	38,000#	18770
For 48" Boom	6" Wide	82 Pitch	38,000#	18771

DIGGING CHAIN OPTIONS

1.654" PITCH DIGGING CHAIN ASSEMBLIES

1.654" PITCH 70/30 COMBINATION DIGGING CHAIN ASSEMBLIES				
Complete chain assemblies. Includes chain with all teeth and spacers attached. Also includes appropriate width crumber shoe.				
615F TRENCHER CHAIN ASSEMBLIES WITH A TOOTH EVERY STATION				
DESCRIPTION (boom used X trench width)		LENGTH OF CHAIN (in 1.654" pitches)	TENSIL STRENGTH	PART NO.
For 24" Boom	6" Wide	64 Pitch	38,000#	89826
For 24" Boom	8" Wide	64 Pitch	38,000#	89827
For 24" Boom	10" Wide	64 Pitch	38,000#	18777
For 24" Boom	12" Wide	64 Pitch	38,000#	18778
For 30" Boom	6" Wide	72 Pitch	38,000#	18996
For 30" Boom	8" Wide	72 Pitch	38,000#	18779
For 30" Boom	10" Wide	72 Pitch	38,000#	18780

NOTE: THESE CHAIN ASSEMBLIES ARE FOR THE FOOTING TRENCHER ONLY!

1.654" PITCH CHAIN REPLACEMENT PARTS

GENERAL INFORMATION

You can purchase individual chain links and pins for your trencher. These can be used to repair a damaged chain, or lengthen and modify an existing chain. Below is a diagram of the chain's basic components with their descriptions and corresponding part numbers. Use these numbers when ordering. You can also order a complete bare chain (without teeth and spacers) in any length desired. The chain is ordered under part number 17015 for 1.654" Pitch. Just specify the length you want in pitches. (See "1.654" PITCH DIGGING CHAIN ASSEMBLIES" chart located in this section.)

When pinning links of chain together, first tap the pin through the connector link with the perfectly round holes and then on through the inner link. Place the second connector link in position, you will note that the end of the pin has one side flattened. Rotate the pin until its flat side lines up with the corresponding flat side of the connector link hole and tap the pin on through. Place the chain keeper pin into the hole at the end of the main pin and tap down tight. Finally, bend the end of the keeper pin over to secure it in place.

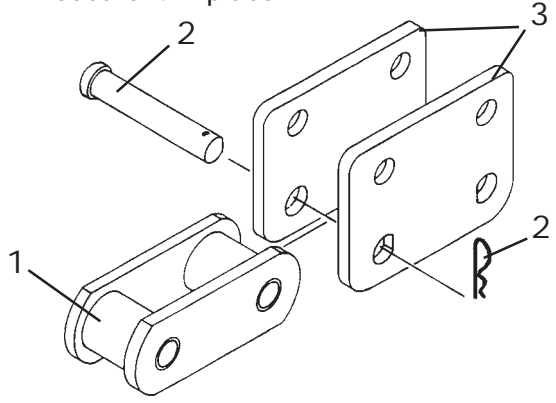

NO.	PART NO.	DESCRIPTION
1	100004	Inner Link
2	100003	Pin & Keeper
3	100005	Connector Link

DIGGING CHAIN OPTIONS

1.654" PITCH DIGGING CHAIN TOOTH STATION SEQUENCE

GENERAL INFORMATION

Every second link on a digging chain is a special link called a digging station. These digging station links are designed so that digging teeth can be bolted onto them in a variety of configurations. It is the number and the make up of these different digging stations that make each chain unique.

The following pages show the various chains available for the 615 and 615F trenchers. The digging tooth make up of each digging station is given in code. The key to the code is listed below. Thus the chain assembly diagrams will show you the order of the digging stations on each digging chain. The actual parts break down of each digging tooth station is also shown on the following pages.

C-D	CENTER SHARK STYLE TOOTH
CL-C	CENTER LEFT CUP TOOTH
CL-D	CENTER LEFT SHARK STYLE TOOTH
CR-C	CENTER RIGHT CUP TOOTH
CR-D	CENTER RIGHT SHARK STYLE TOOTH
4L-C	4" LEFT CUP TOOTH
4L-D	4" LEFT SHARK STYLE TOOTH
4R-C	4" RIGHT CUP TOOTH
4R-D	4" RIGHT SHARK STYLE TOOTH
6L-C	6" LEFT CUP TOOTH
6L-D	6" LEFT SHARK STYLE TOOTH
6R-C	6" RIGHT CUP TOOTH
6R-D	6" RIGHT SHARK STYLE TOOTH
8-C	8" CUP TOOTH
8-D	8" SHARK STYLE TOOTH
10-C	10" CUP TOOTH
10-D	10" SHARK STYLE TOOTH
12-C	12" CUP TOOTH
12-D	12" SHARK STYLE TOOTH

DIGGING CHAIN OPTIONS

DIGGING STATIONS

CUP TOOTH DIGGING STATIONS

CL-C	CR-C	4L-C	4R-C
------	------	------	------

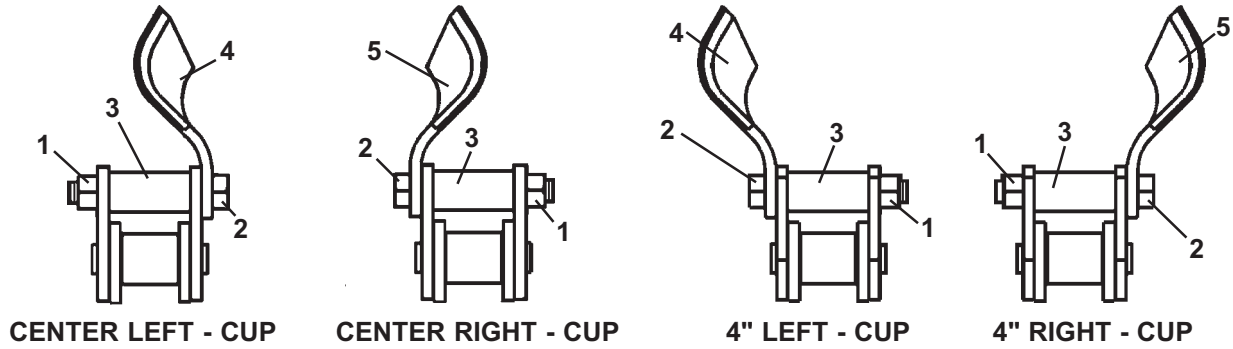

6L-C	6R-C	8-C
------	------	-----

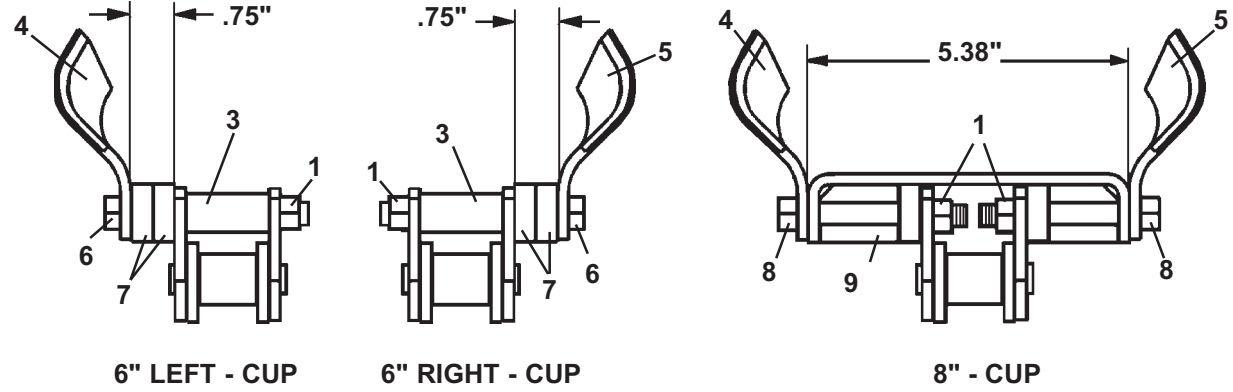

10-C

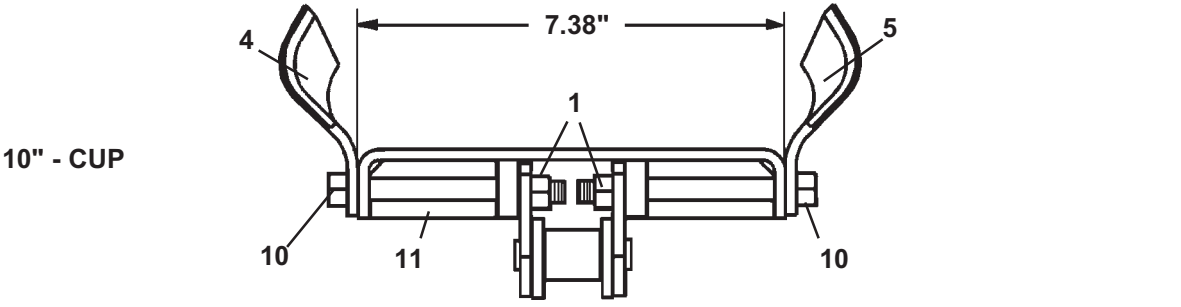

12-C

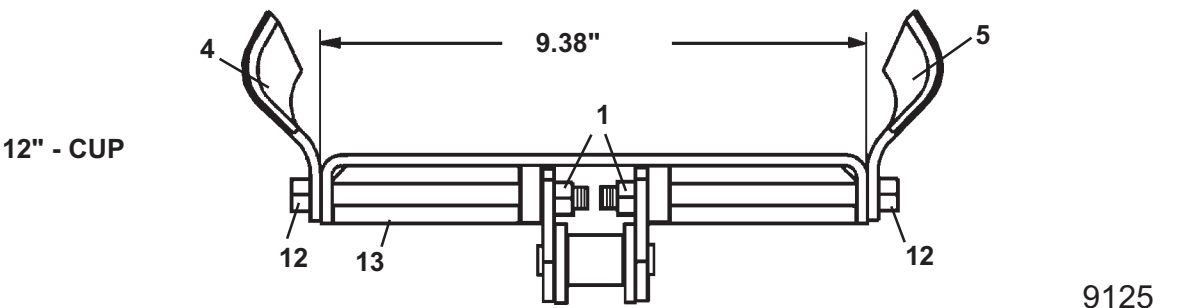

DIGGING CHAIN OPTIONS

DIGGING STATIONS

CUP TOOTH DIGGING STATIONS

<u>NO</u>	<u>PART NO.</u>	<u>DESCRIPTION</u>
1	1796	.38" UNF Lock Nut
2	10053	.38" UNF X 2.50" Hex Capscrew - Grade 8
3	17024	Spacer
4	31595	Left Cup Tooth
5	31596	Right Cup Tooth
6	10054	.38" UNF X 3.25" Hex Capscrew - Grade 8
7	17016	Tooth Spacer
8	10078	.38" UNF X 2.75" Hex Capscrew - Grade 8
9	17017	8" Tooth Spacer
10	10079	.38" UNF X 3.75" Hex Capscrew - Grade 8
11	17018	10" Tooth Spacer
12	10080	.38" UNF X 4.75" Hex Capscrew - Grade 8
13	17019	12" Tooth Spacer

DIGGING CHAIN OPTIONS

DIGGING STATIONS

SHARK STYLE TOOTH DIGGING STATIONS

C-D CL-D CR-D 4L-D 4R-D

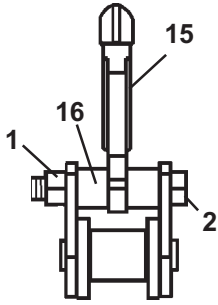

CENTER SHARK STYLE

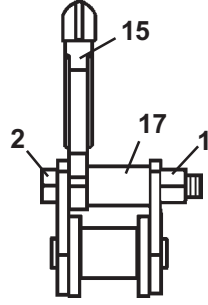

CENTER LEFT SHARK STYLE

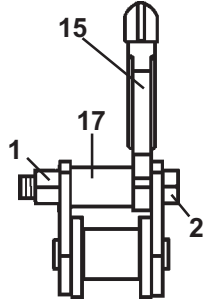

CENTER RIGHT SHARK STYLE

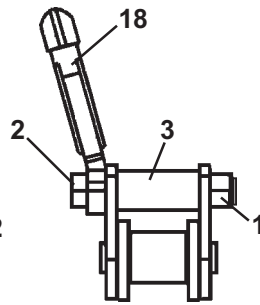

4" LEFT SHARK STYLE

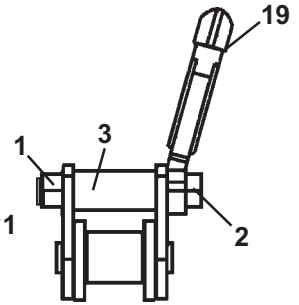

4" RIGHT SHARK STYLE

6L-D 6R-D 8-D

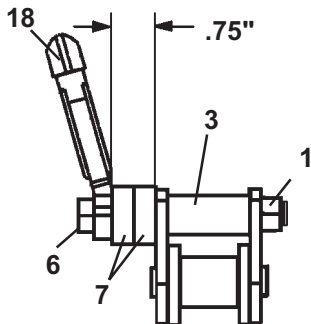

6" LEFT SHARK STYLE

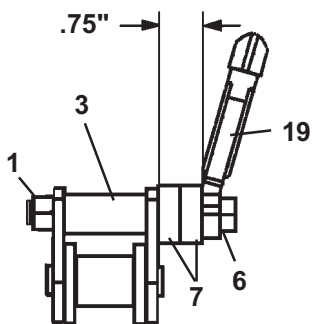

6" RIGHT SHARK STYLE

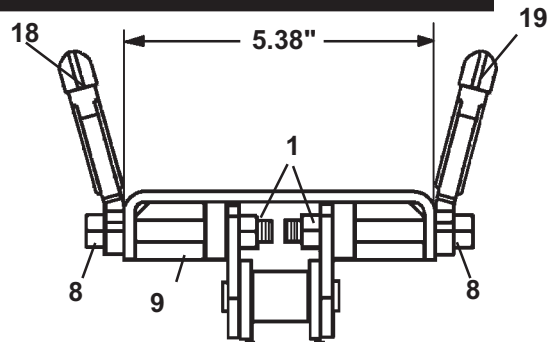

8" SHARK STYLE

10-D

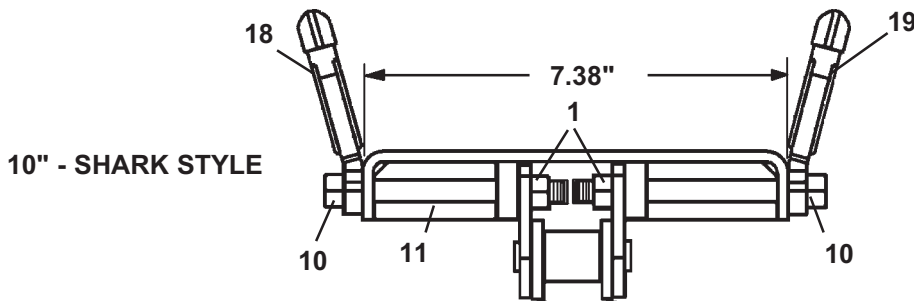

10" - SHARK STYLE

12-D

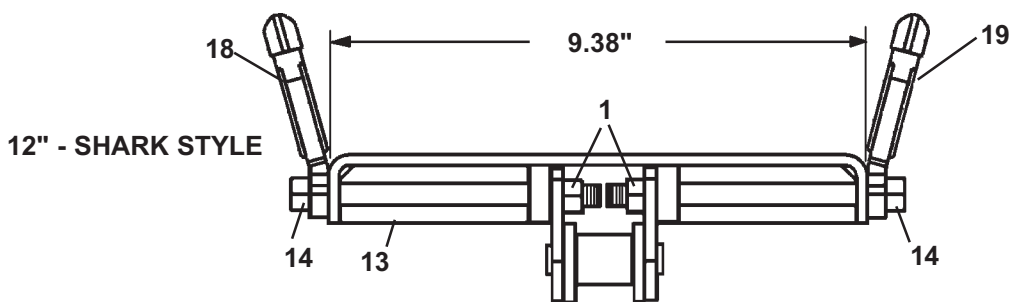

12" - SHARK STYLE

DIGGING CHAIN OPTIONS

DIGGING STATIONS

SHARK STYLE TOOTH DIGGING STATIONS

<u>NO</u>	<u>PART NO.</u>	<u>DESCRIPTION</u>
1	1796	.38" UNF Lock Nut
2	10053	.38" UNF X 2.50" Hex Capscrew - Grade 8
3	17024	Spacer
 (#4, #5 & #12 used on Cup Tooth Digging Stations ONLY)		
6	10054	.38" UNF X 3.25" Hex Capscrew - Grade 8
7	17016	Tooth Spacer
8	10078	.38" UNF X 2.75" Hex Capscrew - Grade 8
9	17017	8" Tooth Spacer
10	10079	.38" UNF X 3.75" Hex Capscrew - Grade 8
11	17018	10" Tooth Spacer
13	17019	12" Tooth Spacer
14	10081	.38" UNF X 5.00" Hex Capscrew - Grade 8
15	31592	Center Shark Style Tooth
16	100001	Spacer
17	100002	Spacer
18	31593	Left Shark Style Tooth
19	31594	Right Shark Style Tooth

DIGGING CHAIN OPTIONS

1.654" PITCH DIGGING CHAIN TOOTH STATION SEQUENCE

GENERAL INFORMATION

Every second link on a digging chain is a special link called a digging station. These digging station links are designed so that digging teeth can be bolted onto them in a variety of configurations. It is the number and the make up of these different digging stations that make each chain unique.

The following pages show the various chains available for the 615 and 615F trenchers. The digging tooth make up of each digging station is given in code. The key to the code is listed below. Thus the chain assembly diagrams will show you the order of the digging stations on each digging chain. The actual parts break down of each digging tooth station is also shown on the following pages.

C-D	CENTER SHARK STYLE TOOTH
CL-C	CENTER LEFT CUP TOOTH
CL-D	CENTER LEFT SHARK STYLE TOOTH
CR-C	CENTER RIGHT CUP TOOTH
CR-D	CENTER RIGHT SHARK STYLE TOOTH
4L-C	4" LEFT CUP TOOTH
4L-D	4" LEFT SHARK STYLE TOOTH
4R-C	4" RIGHT CUP TOOTH
4R-D	4" RIGHT SHARK STYLE TOOTH
6L-C	6" LEFT CUP TOOTH
6L-D	6" LEFT SHARK STYLE TOOTH
6R-C	6" RIGHT CUP TOOTH
6R-D	6" RIGHT SHARK STYLE TOOTH
8-C	8" CUP TOOTH
8-D	8" SHARK STYLE TOOTH
10-C	10" CUP TOOTH
10-D	10" SHARK STYLE TOOTH
12-C	12" CUP TOOTH
12-D	12" SHARK STYLE TOOTH

DIGGING CHAIN OPTIONS

615 TRENCHER WITH 24" BOOM AND CUP TEETH

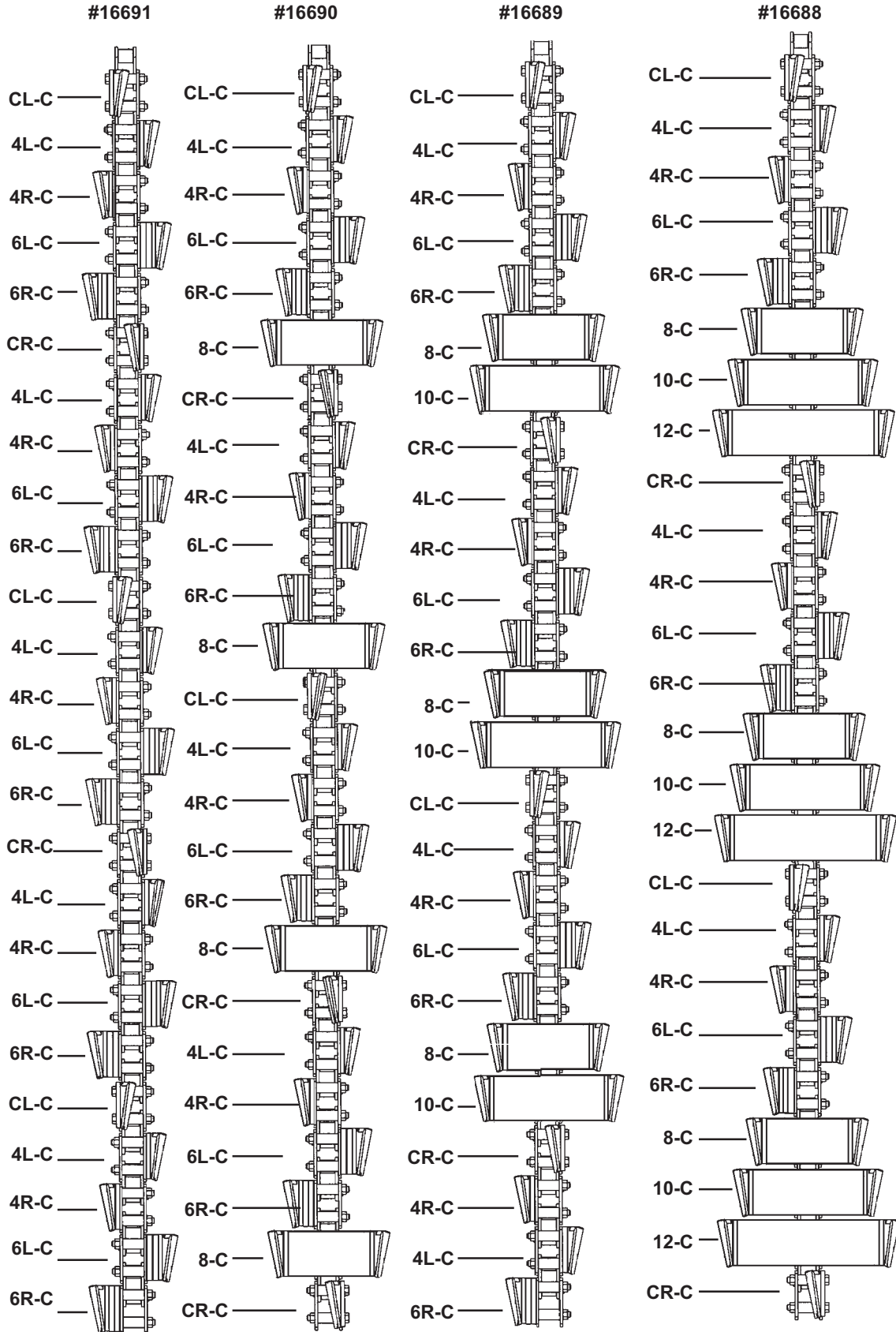

DIGGING CHAIN OPTIONS

615 TRENCHER WITH 30" BOOM AND CUP TEETH

#16686

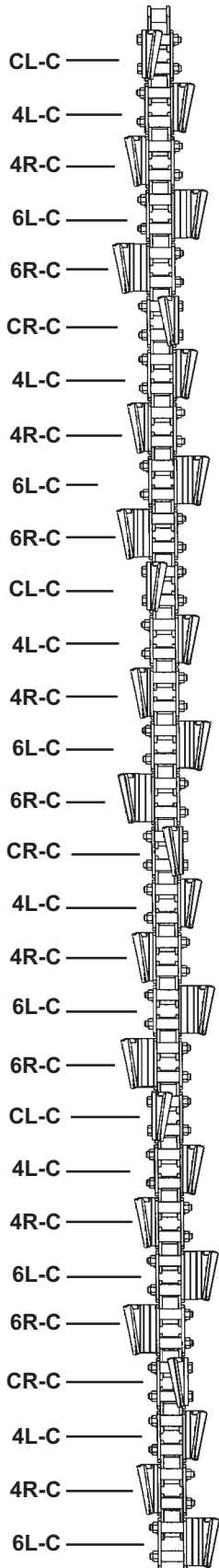

#16685

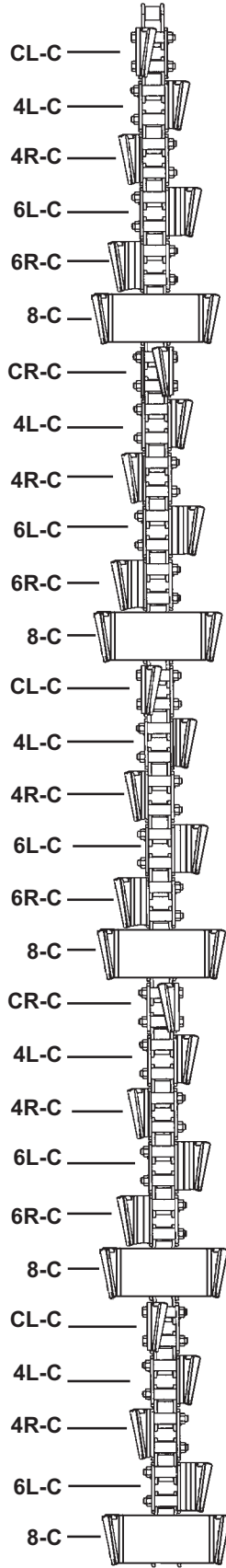

#16684

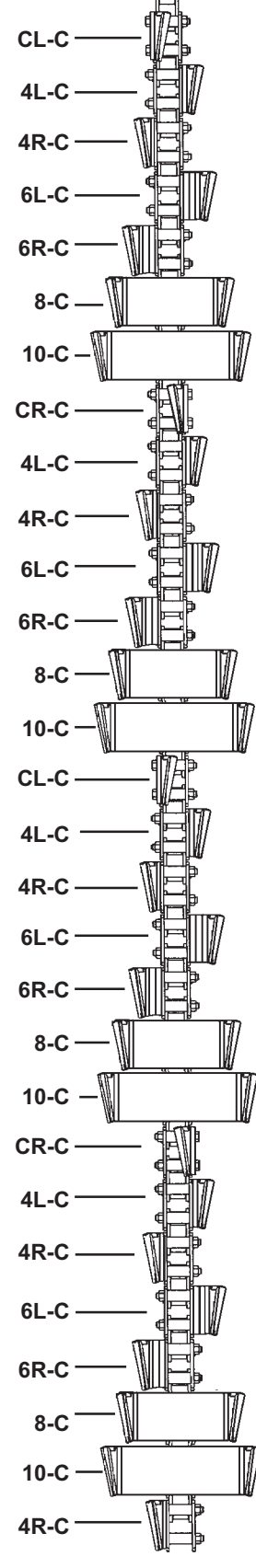

DIGGING CHAIN OPTIONS

615 TRENCHER WITH 36" BOOM AND CUP TEETH

#89822

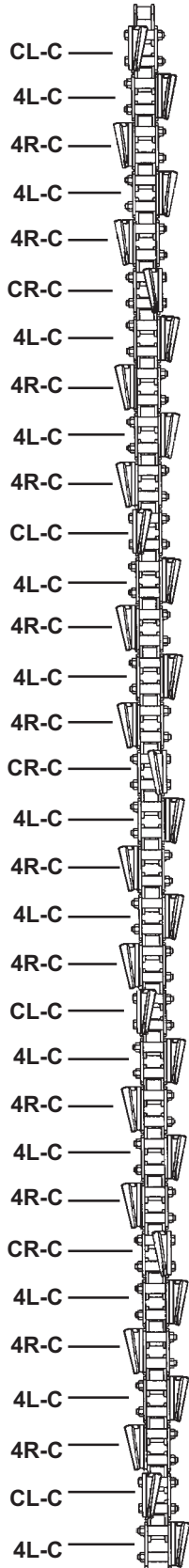

#89823

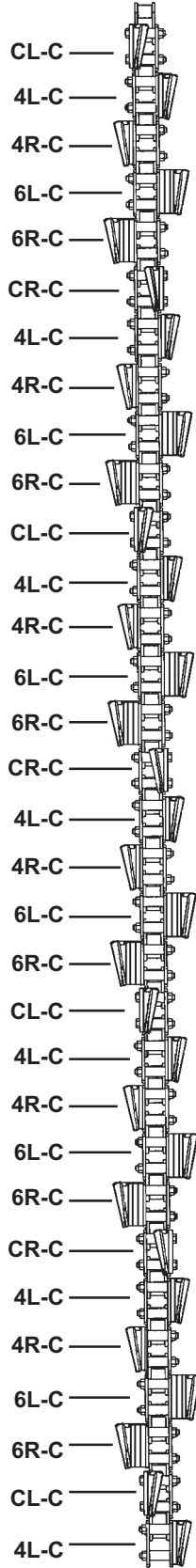

#89824

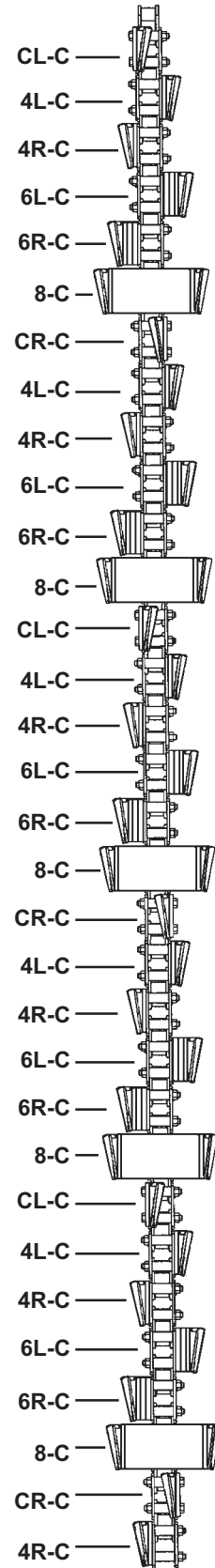

DIGGING CHAIN OPTIONS

615 TRENCHER WITH 48" BOOM AND CUP TEETH

#18772

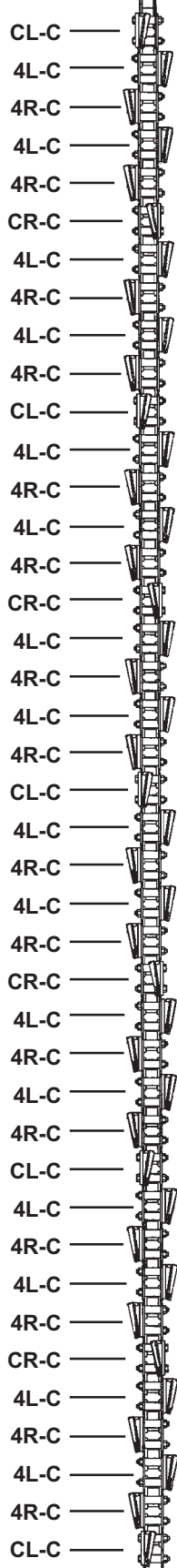

#18773

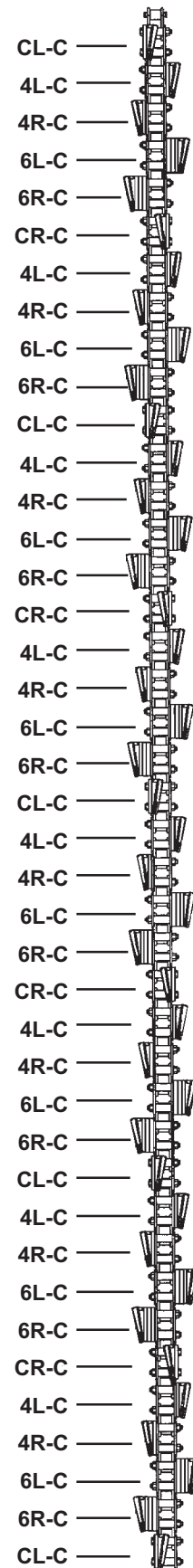

DIGGING CHAIN OPTIONS

615 TRENCHER WITH 24" BOOM AND 70/30 COMBINATION TEETH

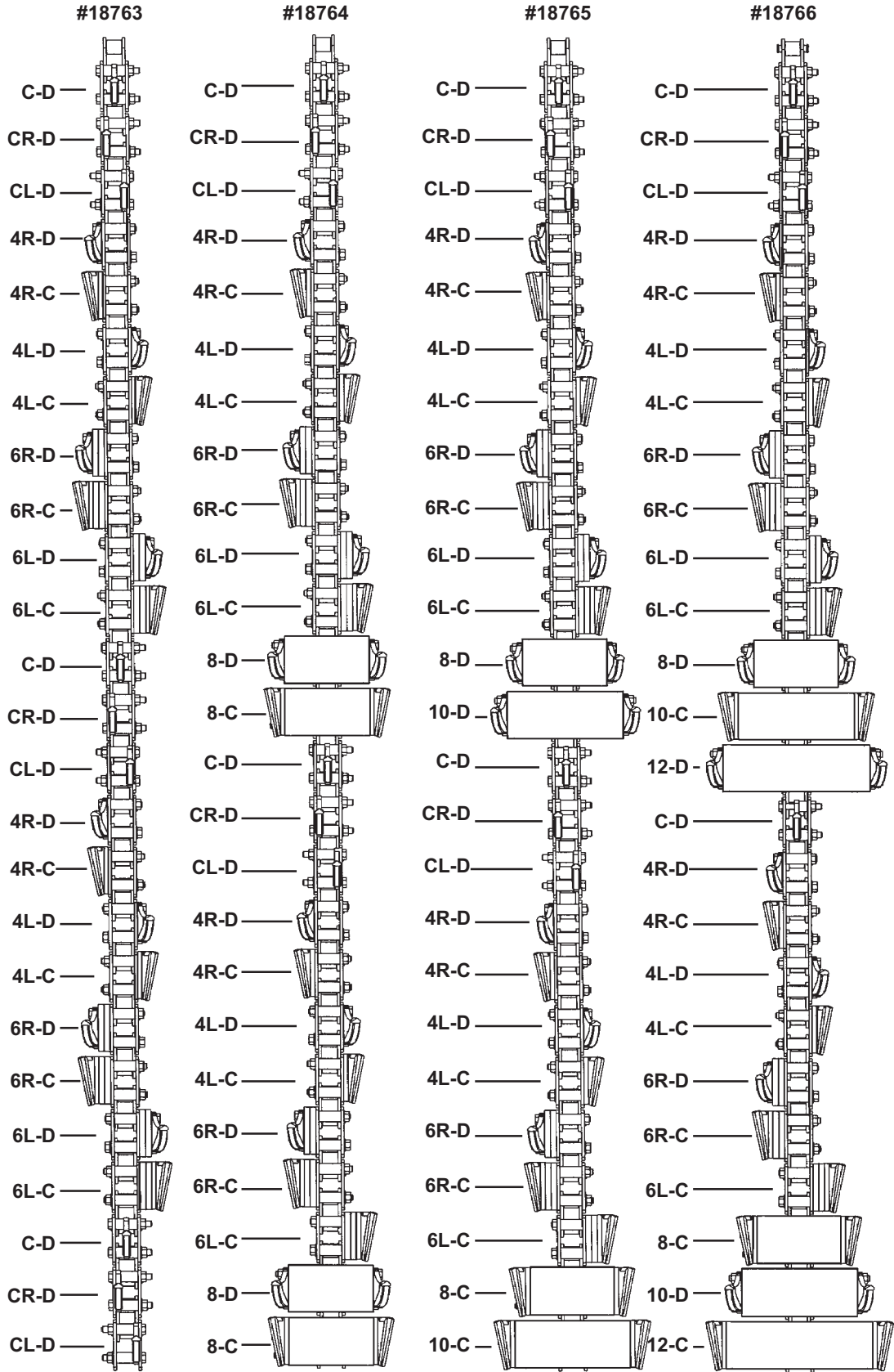

DIGGING CHAIN OPTIONS

615 TRENCHER WITH 30" BOOM AND 70/30 COMBINATION TEETH

#18767

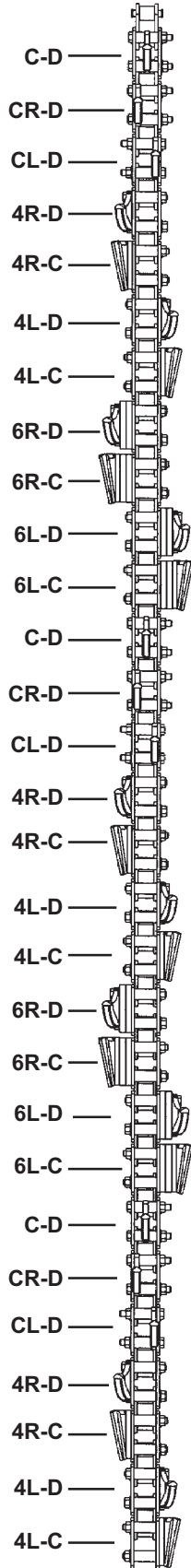

#18768

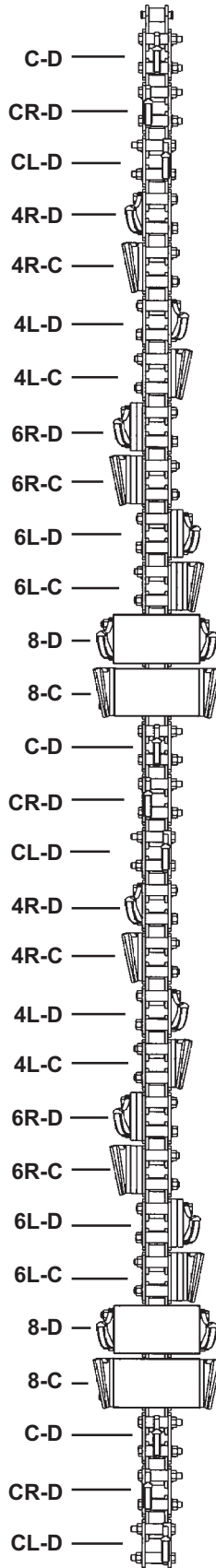

#18769

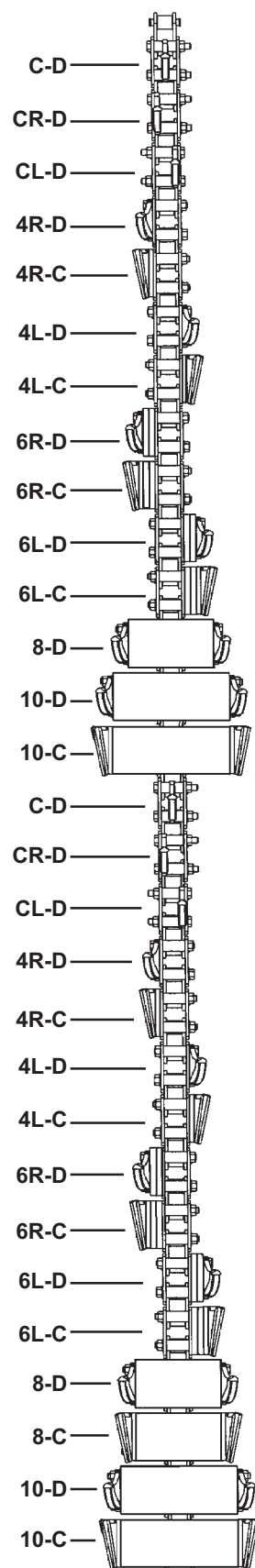

DIGGING CHAIN OPTIONS

615 TRENCHER WITH 36" BOOM AND 70/30 COMBINATION TEETH

#89825

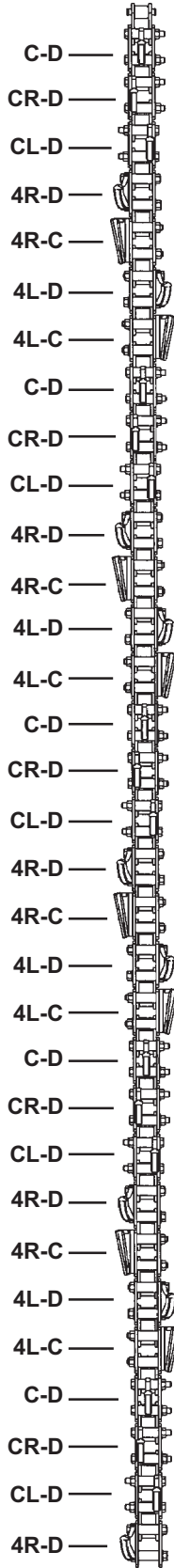

#89826

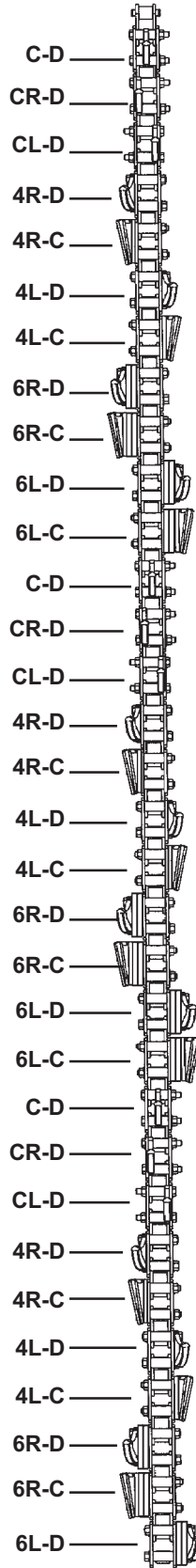

#89827

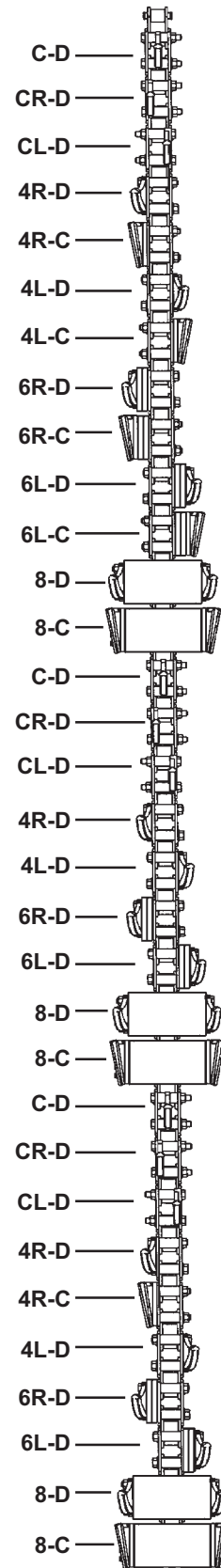

DIGGING CHAIN OPTIONS

615 TRENCHER WITH 48" BOOM AND 70/30 COMBINATION TEETH

#18770

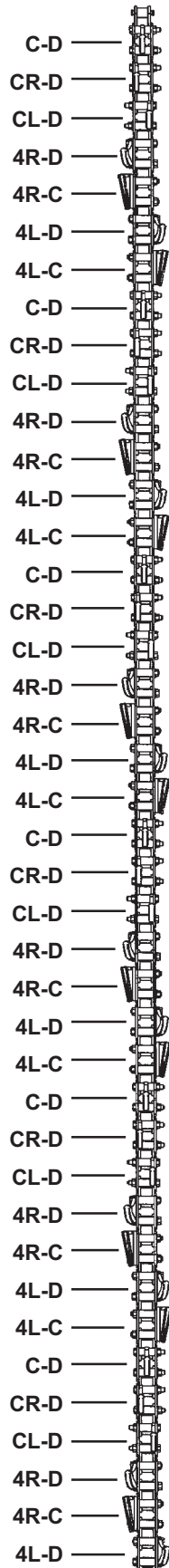

#18771

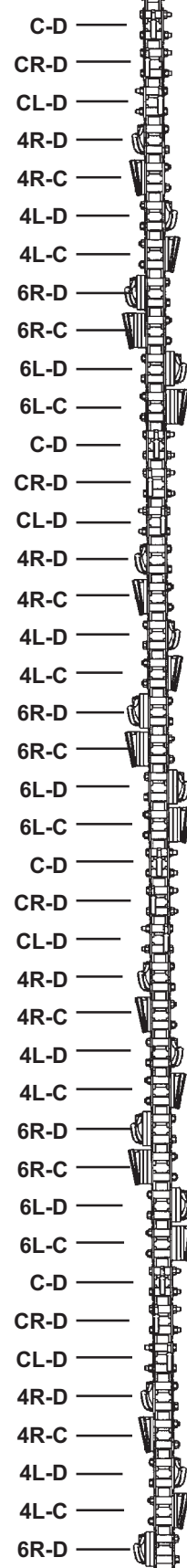

DIGGING CHAIN OPTIONS

615F TRENCHER WITH 24" BOOM AND CUP TEETH

#89823

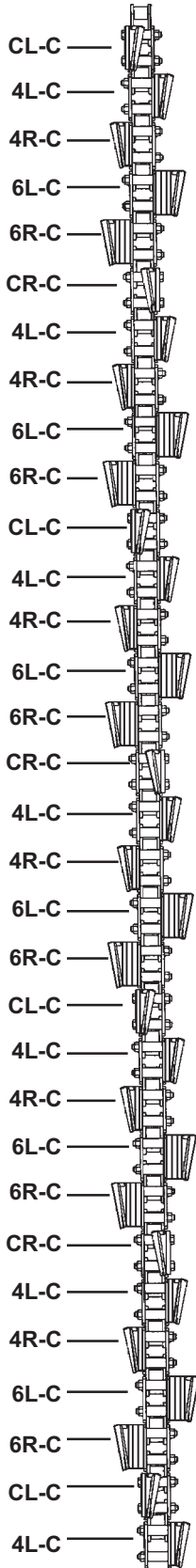

#89824

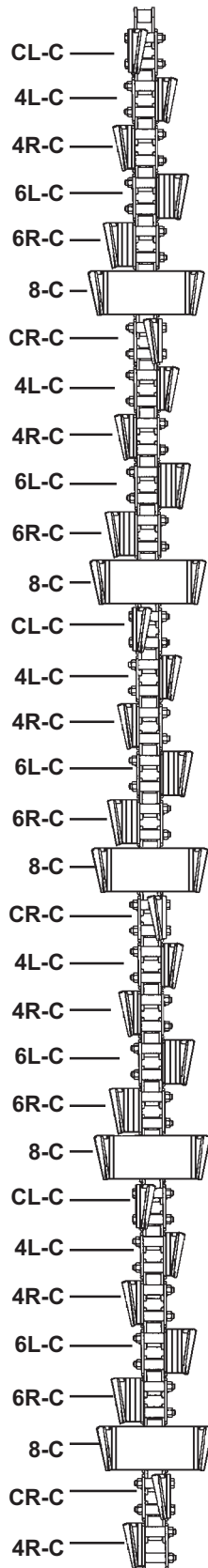

#16681

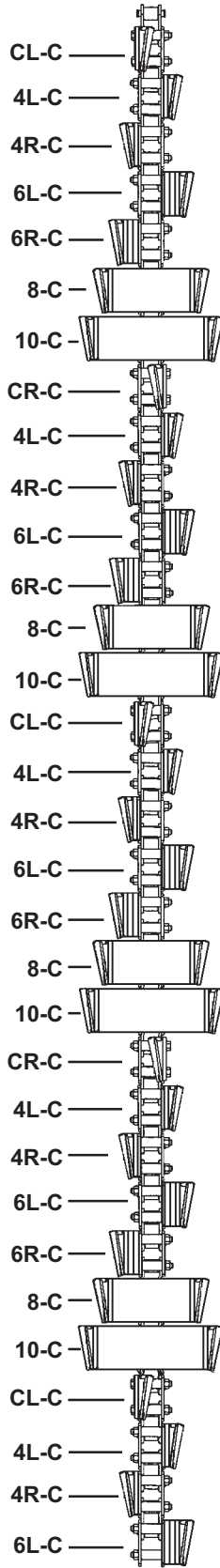

#16682

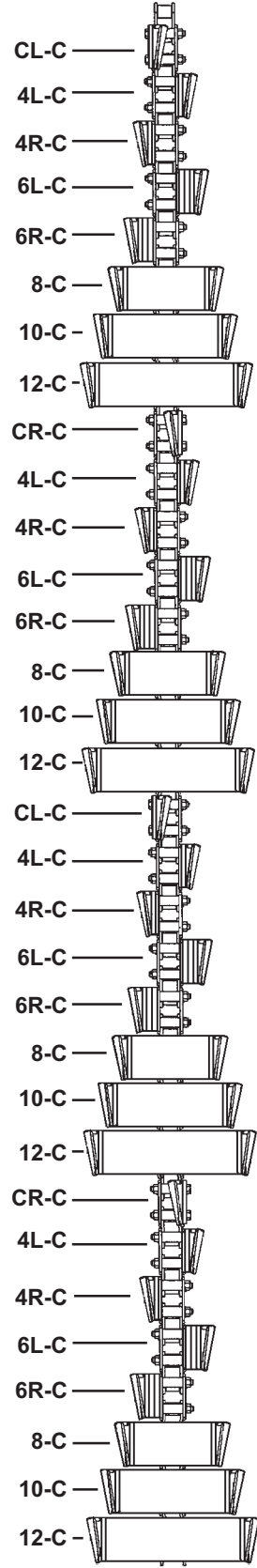

DIGGING CHAIN OPTIONS

615F TRENCHER WITH 30" BOOM AND CUP TEETH

#18909

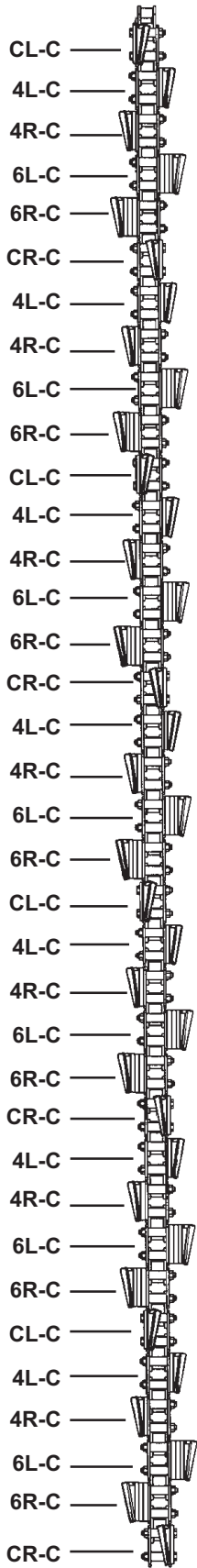

#18774

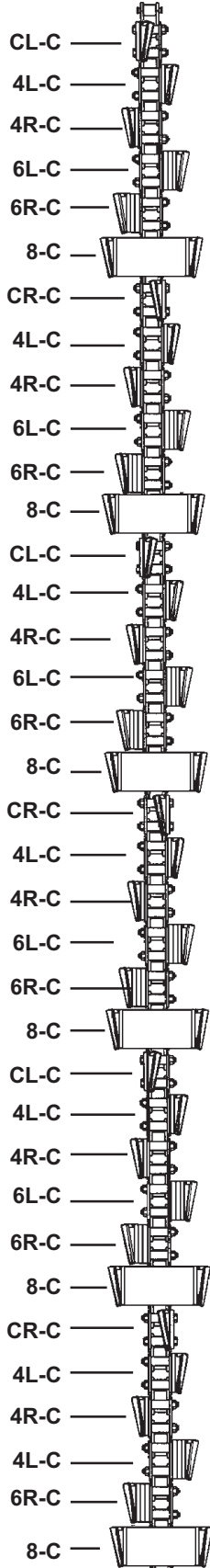

#18775

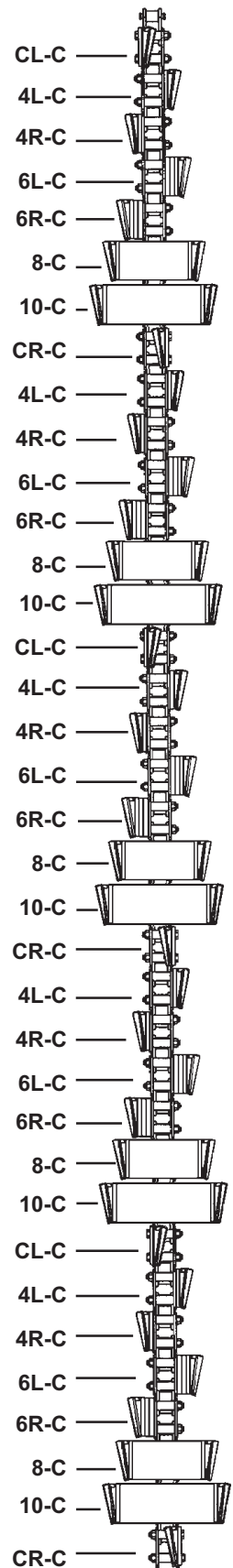

DIGGING CHAIN OPTIONS

615F TRENCHER WITH 24" BOOM AND 70/30 COMBINATION TEETH

#89826

#89827

#18777

#18778

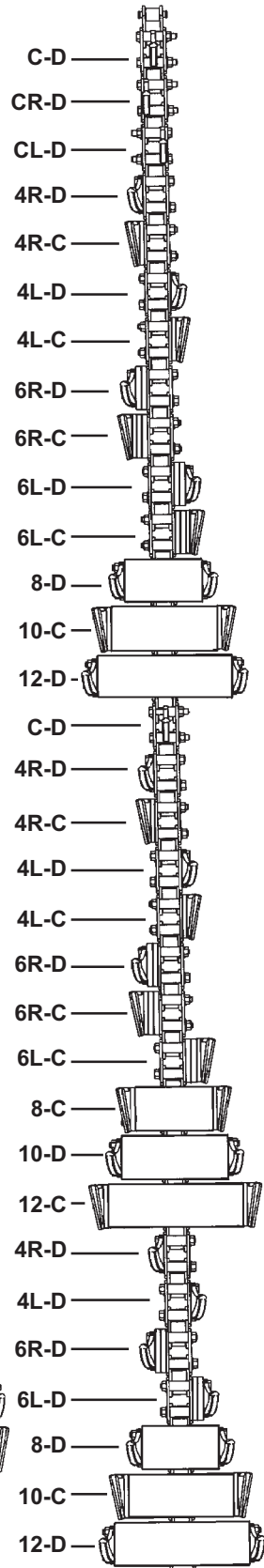
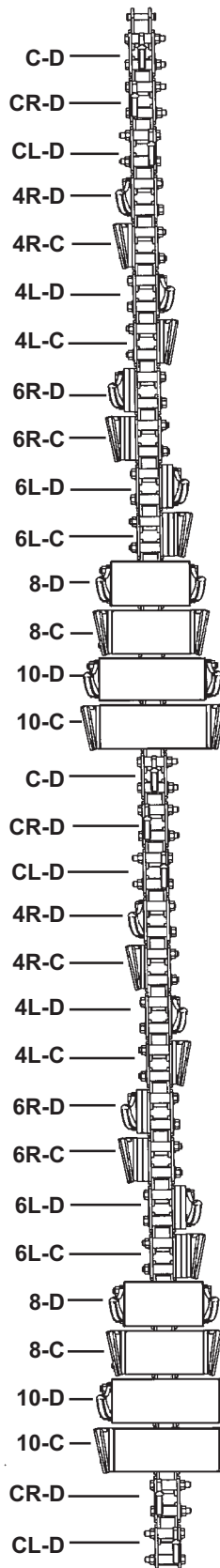
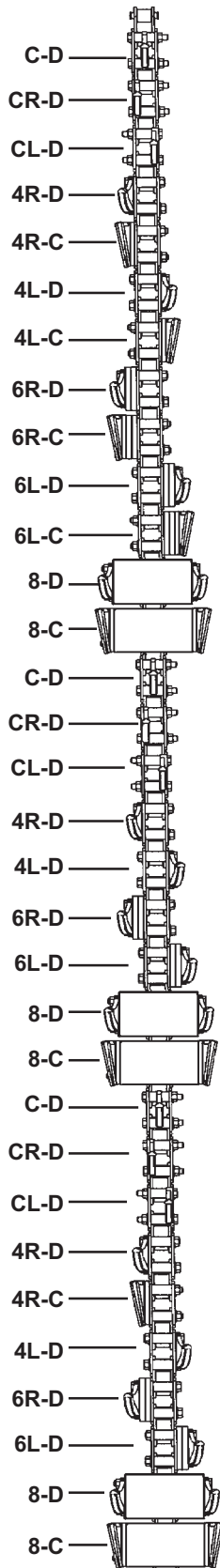
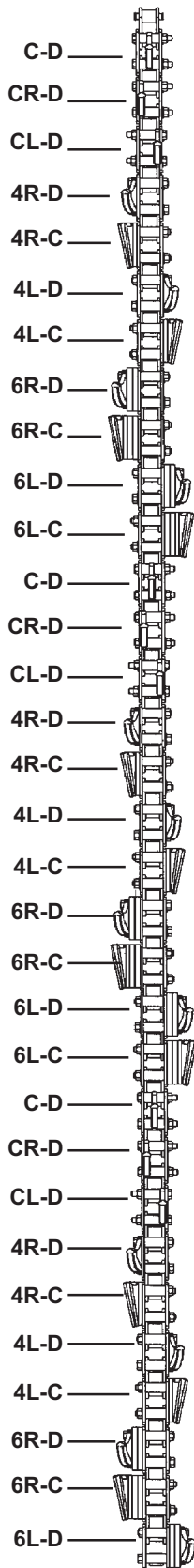

DIGGING CHAIN OPTIONS

615F TRENCHER WITH 30" BOOM AND 70/30 COMBINATION TEETH

#18996

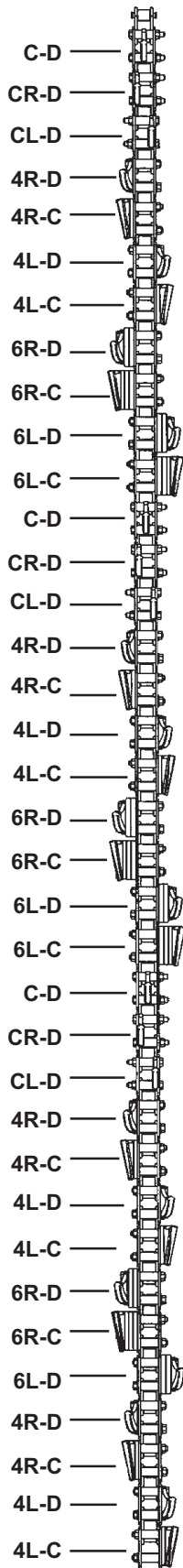

#18779

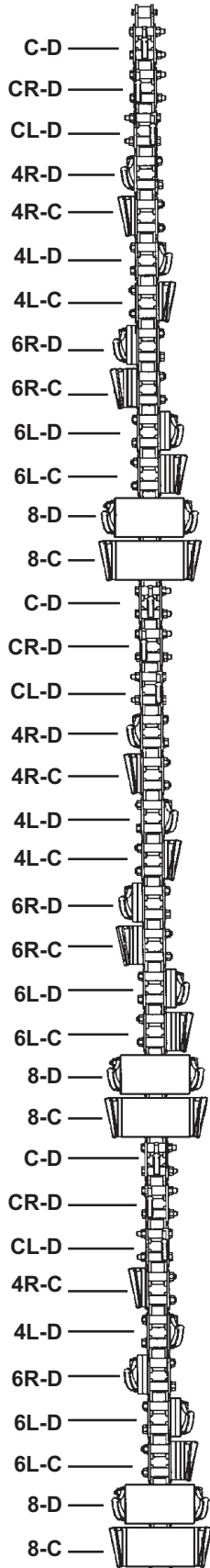

#18780

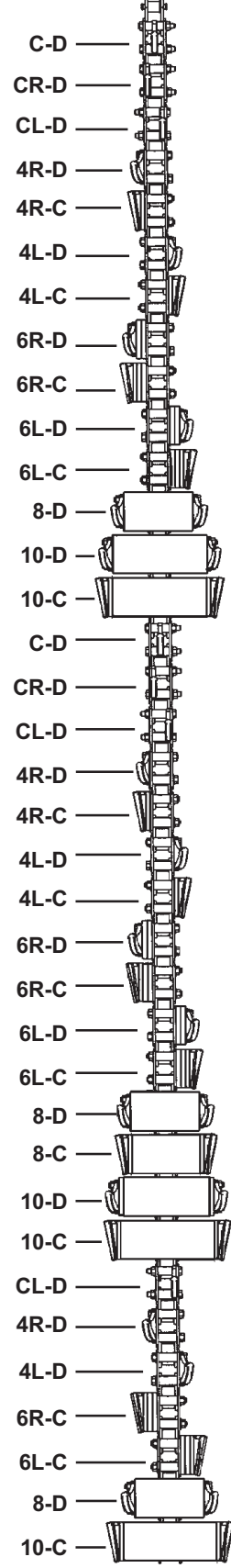

DIGGING CHAIN OPTIONS

1.654" PITCH DIGGING CHAIN WIDTH CONVERSIONS FOR 615 TRENCHER

GENERAL INFORMATION

Digging chains can be modified to dig trenches in a variety of widths. By modifying an existing chain, it can be used to dig the width you want and thus save going the expense of a whole new digging chain assembly. This can be a considerable cost savings, however it is more work than just installing a new digging chain assembly.

The information given below is a complete listing of all the possible chain width conversions for 1.654" pitch chain for your trencher. Included in the listing is a break down of all the parts (including part numbers and quantities) needed to make the conversion. Simply install the new parts (and re-arrange the old parts) so that the finished chain construction follows that shown in the diagram of the digging chains and the digging station break down diagrams for the 1.654" pitch chain (located elsewhere in this section).

It should be noted that this information only applies to modifying chains of the same length and pitch. All components must be of the same pitch. You cannot intermix components of different pitch.

615 TRENCHER CHAIN CONVERSIONS FOR 24" BOOMS - CUP TEETH

1) FROM 6" WIDE TO 8" WIDE (Kit #17079)

<u>REQ'D</u>	<u>PART NO.</u>	<u>DESCRIPTION</u>
8	1796	.38" UNF Lock Nut
1	31595	Left Cup Tooth
3	31596	Right Cup Tooth
16	10078	.38" UNF X 2.75" Hex Capscrew - Grade 8
4	17017	8" Tooth Spacer
1	53055	8" Crumber Shoe

New stations: (4) 8-C (1) CR-C Remove: (1) CL-C (1) 4L-C (1) 4R-C (1) 6L-C (1) 6R-C

2) FROM 8" WIDE TO 6" WIDE (Order seperately)

<u>REQ'D</u>	<u>PART NO.</u>	<u>DESCRIPTION</u>
4	10053	.38" UNF X 2.50" Hex Capscrew - Grade 8
4	10054	.38" UNF X 3.25" Hex Capscrew - Grade 8
8	17024	Spacer
4	17016	Tooth Spacer
1	53054	6" Crumber Shoe

New stations: (1) 4L-C (1) 4R-C (1) 6L-C (1) 6R-C (1) CL-C Remove: (4) 8-C (1) CR-C

3) FROM 6" WIDE TO 10" WIDE (Kit #17080)

<u>REQ'D</u>	<u>PART NO.</u>	<u>DESCRIPTION</u>
12	1796	.38" UNF Lock Nut
2	31595	Left Cup Tooth
4	31596	Right Cup Tooth
12	10078	.38" UNF X 2.75" Hex Capscrew - Grade 8
3	17017	8" Tooth Spacer
12	10079	.38" UNF X 3.75" Hex Capscrew - Grade 8
3	17018	10" Tooth Spacer
1	53058	10" Crumber Shoe

New stations: (3) 8-C (3) 10-C Remove: (2) 6L-C (1) CL-C (1) 4L-C (1) 4R-C (1) 6R-C

DIGGING CHAIN OPTIONS

1.654" PITCH DIGGING CHAIN WIDTH CONVERSIONS FOR 615 TRENCHER

4) FROM 10" WIDE TO 6" WIDE (Order seperately)

<u>REQ'D</u>	<u>PART NO.</u>	<u>DESCRIPTION</u>
6	10053	.38" UNF X 2.50" Hex Capscrew - Grade 8
6	10054	.38" UNF X 3.25" Hex Capscrew - Grade 8
12	17024	Spacer
6	17016	Tooth Spacer
1	53054	6" Crumber Shoe

New stations: (3) 8-C (3) 10-C Remove: (2) 6L-C (1) CL-C (1) 4L-C (1) 4R-C (1) 6R-C

5) FROM 6" WIDE TO 12" WIDE (Kit #17081)

<u>REQ'D</u>	<u>PART NO.</u>	<u>DESCRIPTION</u>
18	1796	.38" UNF Lock Nut
4	31595	Left Cup Tooth
5	31596	Right Cup Tooth
3	17017	8" Tooth Spacer
12	10078	.38" UNF X 2.75" Hex Capscrew - Grade 8
12	10079	.38" UNF X 3.75" Hex Capscrew - Grade 8
3	17018	10" Tooth Spacer
12	10080	.38" UNF X 4.75" Hex Capscrew - Grade 8
3	17019	12" Tooth Spacer
1	53059	12" Crumber Shoe

New stations: (3) 8-C (3)10-C (3)12-C Remove: (2) 4L-C (2) 4R-C (2) 6L-C (2) 6R-C (1) CL-C

6) FROM 12" WIDE TO 6" WIDE (Order seperately)

<u>REQ'D</u>	<u>PART NO.</u>	<u>DESCRIPTION</u>
10	10053	.38" UNF X 2.50" Hex Capscrew - Grade 8
8	10054	.38" UNF X 3.25" Hex Capscrew - Grade 8
18	19024	Spacer
8	17016	Tooth Spacer
1	53054	6" Crumber Shoe

New stations: (2) 4L-C (2) 4R-C (2) 6L-C (2) 6R-C (1) CL-C Remove: (3) 8-C (3) 10-C (3) 12-C

7) FROM 8" WIDE TO 10" WIDE (Kit #17082)

<u>REQ'D</u>	<u>PART NO.</u>	<u>DESCRIPTION</u>
2	1796	.38" UNF Lock Nut
1	31595	Left Cup Tooth
1	31596	Right Cup Tooth
12	10079	.38" UNF X 3.75" Hex Capscrew - Grade 8
3	17018	10" Tooth Spacer
1	53058	10" Crumber Shoe

New stations: (3) 10-C Remove: (1) 6L-C (1) 8-C (1) CR-C

8) FROM 10" WIDE TO 8" WIDE (Order seperately)

<u>REQ'D</u>	<u>PART NO.</u>	<u>DESCRIPTION</u>
2	10053	.38" UNF X 2.50" Hex Capscrew - Grade 8
2	10054	.38" UNF X 3.25" Hex Capscrew - Grade 8
4	17024	Spacer
2	17016	Tooth Spacer
4	10078	.38" UNF X 2.75" Hex Capscrew - Grade 8
1	17017	8" Tooth Spacer
1	53055	8" Crumber Shoe

New stations: (1) 6L-C (1) 8-C (1) CR-C Remove: (3) 10-C

DIGGING CHAIN OPTIONS

1.654" PITCH DIGGING CHAIN WIDTH CONVERSIONS FOR 615 TRENCHER

9) FROM 8" WIDE TO 12" WIDE (Kit #17083)

<u>REQ'D</u>	<u>PART NO.</u>	<u>DESCRIPTION</u>
10	1796	.38" UNF Lock Nut
3	31595	Left Cup Tooth
2	31596	Right Cup Tooth
12	10079	.38" UNF X 3.75" Hex Capscrew - Grade 8
3	17018	10" Tooth Spacer
12	10080	.38" UNF X 4.75" Hex Capscrew - Grade 8
3	17019	12" Tooth Spacer
1	53059	12" Crumber Shoe

New stations:(3) 10-C (3) 12-C Remove: (1) 4R-C (1) 4L-C (1) 6R-C (1) 6L-C (1) 8-C (1) CL-C

10) FROM 12" WIDE TO 8" WIDE (Order seperately)

<u>REQ'D</u>	<u>PART NO.</u>	<u>DESCRIPTION</u>
6	10053	.38" UNF X 2.50" Hex Capscrew - Grade 8
4	10054	.38" UNF X 3.25" Hex Capscrew - Grade 8
10	17024	Spacer
4	17016	Tooth Spacer
4	10078	.38" UNF X 2.75" Hex Capscrew - Grade 8
1	17017	8" Tooth Spacer
1	53055	8" Crumber Shoe

New stations: (1) 4R-C (1) 4L-C (1) 6R-C (1) 6L-C (1) 8-C (1) CL-C Remove: (3) 10-C (3) 12-C

11) FROM 10" WIDE TO 12" WIDE (Kit #17084)

<u>REQ'D</u>	<u>PART NO.</u>	<u>DESCRIPTION</u>
6	1796	.38" UNF Lock Nut
2	31595	Left Cup Tooth
1	31596	Right Cup Tooth
12	10080	.38" UNF X 4.75" Hex Capscrew - Grade 8
3	17019	12" Tooth Spacer
1	53059	12" Crumber Shoe

New stations: (3) 12-C Remove: (1) 4R-C (1) 4L-C (1) 6R-C

12) FROM 12" WIDE TO 10" WIDE (Order seperately)

<u>REQ'D</u>	<u>PART NO.</u>	<u>DESCRIPTION</u>
4	10053	.38" UNF X 2.50" Hex Capscrew - Grade 8
2	10054	.38" UNF X 3.25" Hex Capscrew - Grade 8
6	17024	Spacer
2	17016	Tooth Spacer
1	53058	10" Crumber Shoe

New Stations: (1) 4R-C (1) 4L-C (1) 6R-C Remove: (3) 12-C

615 TRENCHER CHAIN CONVERSIONS FOR 30" BOOMS - CUP TEETH

1) FROM 6" WIDE TO 8" WIDE (Kit #17085)

<u>REQ'D</u>	<u>PART NO.</u>	<u>DESCRIPTION</u>
10	1796	.38" UNF Lock Nut
3	31595	Left Cup Tooth
2	31596	Right Cup Tooth
20	10078	.38" UNF X 2.75" Hex Capscrew - Grade 8
5	17017	8" Tooth Spacer
1	53055	8" Crumber Shoe

New stations: (5) 8-C Remove: (1) CR-C (1) 4L-C (1) 4R-C (1) 6L-C (1) 6R-C

DIGGING CHAIN OPTIONS

1.654" PITCH DIGGING CHAIN WIDTH CONVERSIONS FOR 615 TRENCHER

2) FROM 8" WIDE TO 6" WIDE (Order seperately)

<u>REQ'D</u>	<u>PART NO.</u>	<u>DESCRIPTION</u>
6	10053	.38" UNF X 2.50" Hex Capscrew - Grade 8
4	10054	.38" UNF X 3.25" Hex Capscrew - Grade 8
10	17024	Spacer
4	17016	Tooth Spacer
1	53054	6" Crumber Shoe

New stations: (1) 4L-C (1) 4R-C (1) 6L-C (1) 6R-C (1)CR-C Remove: (5) 8-C

3) FROM 6" WIDE TO 10" WIDE (Kit #17086)

<u>REQ'D</u>	<u>PART NO.</u>	<u>DESCRIPTION</u>
24	1796	.38" UNF Lock Nut
3	31595	Left Cup Tooth
5	31596	Right Cup Tooth
16	10078	.38" UNF X 2.75" Hex Capscrew - Grade 8
4	17017	8" Tooth Spacer
16	10079	.38" UNF X 3.75" Hex Capscrew - Grade 8
4	17018	10" Tooth Spacer
1	53058	10" Crumber Shoe

New stations: (4) 8-C (4) 10-C Remove: (2) 6L-C (1) CL-C (2) 4L-C (1) 4R-C (1) 6R-C (1) CR-C

4) FROM 10" WIDE TO 6" WIDE (Order seperately)

<u>REQ'D</u>	<u>PART NO.</u>	<u>DESCRIPTION</u>
10	10053	.38" UNF X 2.50" Hex Capscrew - Grade 8
6	10054	.38" UNF X 3.25" Hex Capscrew - Grade 8
16	17024	Spacer
6	17016	Tooth Spacer
1	53054	6" Crumber Shoe

New stations: (2) 4L-C (1) 4R-C (1) 6R-C (2) 6L-C (1) CL-C (1) CR-C Remove: (4) 8-C (4) 10-C

5) FROM 8" WIDE TO 10" WIDE (Kit #17088)

<u>REQ'D</u>	<u>PART NO.</u>	<u>DESCRIPTION</u>
14	1796	.38" UNF Lock Nut
3	31596	Right Cup Tooth
16	10079	.38" UNF X 3.75" Hex Capscrew - Grade 8
4	17018	10" Tooth Spacer
1	53058	10" Crumber Shoe

New stations: (4) 10-C Remove: (1) 6L-C (1) 8-C (1) CL-C (1) 4L-C

6) FROM 10" WIDE TO 8" WIDE (Order seperately)

<u>REQ'D</u>	<u>PART NO.</u>	<u>DESCRIPTION</u>
4	10053	.38" UNF X 2.50" Hex Capscrew - Grade 8
2	10054	.38" UNF X 3.25" Hex Capscrew - Grade 8
6	17024	Spacer
2	17016	Tooth Spacer
4	10078	.38" UNF X 2.75" Hex Capscrew - Grade 8
1	17017	8" Tooth Spacer
1	53055	8" Crumber Shoe

New Stations: (1) 6L-C (1) 8-C (1) CL-C (1) 4L-C Remove: (4) 10-C

DIGGING CHAIN OPTIONS

1.654" PITCH DIGGING CHAIN WIDTH CONVERSIONS FOR 615 TRENCHER

615 TRENCHER CHAIN CONVERSIONS FOR 36" BOOMS - CUP TEETH

1) FROM 4.50" WIDE TO 6" WIDE (Kit #100014)

<u>REQ'D</u>	<u>PART NO.</u>	<u>DESCRIPTION</u>
24	17016	Tooth Spacer
24	10054	.38" UNF X 3.25" Hex Capscrew - Grade 8
1	53054	6" Crumber Shoe

New stations: (6) 6L-C (6) 6R-C Remove: (6) 4L-C (6) 4R-C

2) FROM 6" WIDE TO 4.50" WIDE (Order seperately)

<u>REQ'D</u>	<u>PART NO.</u>	<u>DESCRIPTION</u>
24	10053	.38" UNF X 2.50" Hex Capscrew - Grade 8
1	59808	4.5" Crumber Shoe

New stations: (6) 4L-C (6) 4R-C Remove: (6) 6L-C (6) 6R-C

3) FROM 4.50" WIDE TO 8" WIDE (Kit #100015)

<u>REQ'D</u>	<u>PART NO.</u>	<u>DESCRIPTION</u>
10	1796	.38" UNF Lock Nut
1	31595	Left Cup Tooth
4	31596	Right Cup Tooth
20	10054	.38" UNF X 3.25" Hex Capscrew - Grade 8
20	17016	Tooth Spacer
20	10078	.38" UNF X 2.75" Hex Capscrew - Grade 8
5	17017	8" Tooth Spacer
1	53055	8" Crumber Shoe

New stations: (5) 8-C (5) 6L-C (5) 6R-C Remove: (1) CL-C (8) 4L-C (6) 4R-C

4) FROM 8" WIDE TO 4.50" WIDE (Order seperately)

<u>REQ'D</u>	<u>PART NO.</u>	<u>DESCRIPTION</u>
30	10053	.38" UNF X 2.50" Hex Capscrew - Grade 8
10	17024	Spacer
1	59808	4.5" Crumber Shoe

New stations: (8) 4L-C (6) 4R-C (1) CL-C Remove: (5) 8-C (5) 6L-C (5) 6R-C

5) FROM 6" WIDE TO 8" WIDE (Kit #17091)

<u>REQ'D</u>	<u>PART NO.</u>	<u>DESCRIPTION</u>
10	1796	.38" UNF Lock Nut
1	31595	Left Cup Tooth
4	31596	Right Cup Tooth
20	10078	.38" UNF X 2.75" Hex Capscrew - Grade 8
5	17017	8" Tooth Spacer
1	53055	8" Crumber Shoe

New station: (5) 8-C Remove: (1) 6L-C (1) 6R-C (1) CL-C (2) 4L-C

6) FROM 8" WIDE TO 6" WIDE (Order seperately)

<u>REQ'D</u>	<u>PART NO.</u>	<u>DESCRIPTION</u>
6	10053	.38" UNF X 2.50" Hex Capscrew - Grade 8
10	17024	Spacer
4	10054	.38" UNF X 3.25" Hex Capscrew - Grade 8
4	17016	Tooth Spacer
1	53054	6" Crumber Shoe

New Stations: (1) 6L-C (1) 6R-C (1) CL-C (2) 4L-C Remove: (5) 8-C

DIGGING CHAIN OPTIONS

1.654" PITCH DIGGING CHAIN WIDTH CONVERSIONS FOR 615 TRENCHER

615 TRENCHER CHAIN CONVERSIONS FOR 48" BOOMS - CUP TEETH

1) FROM 4.50" WIDE TO 6" WIDE (Kit #100016)

<u>REQ'D</u>	<u>PART NO.</u>	<u>DESCRIPTION</u>
32	10054	.38" UNF X 3.25" Hex Capscrew - Grade 8
32	17016	Tooth Spacer
1	53054	6" Crumber Shoe

New stations: (8) 6L-C (8) 6R-C Remove: (8) 4L-C (8) 4R-C

2) FROM 6" WIDE TO 4.50" WIDE (Order seperately)

<u>REQ'D</u>	<u>PART NO.</u>	<u>DESCRIPTION</u>
32	10053	.38" UNF X 2.50" Hex Capscrew - Grade 8
1	59808	4.5" Crumber Shoe

New stations: (8) 4L-C (8) 4R-C Remove: (8) 6L-C (8) 6R-C

615 TRENCHER CHAIN CONVERSIONS FOR 24" BOOMS - 70/30 COMBINATION

1) FROM 6" WIDE TO 8" WIDE (Kit #100017)

<u>REQ'D</u>	<u>PART NO.</u>	<u>DESCRIPTION</u>
8	1796	.38" UNF Lock Nut
1	31593	Left Shark Style Tooth
2	31594	Right Shark Style Tooth
2	31595	Left Cup Tooth
2	31596	Right Cup Tooth
16	10078	.38" UNF X 2.75" Hex Capscrew - Grade 8
4	17017	8" Tooth Spacer
1	53055	8" Crumber Shoe

New stations: (2) 8-C (2) 8-D Remove: (1) 6L-D (1) C-D (1) CR-D (1) CL-D

2) FROM 8" WIDE TO 6" WIDE (Order seperately)

<u>REQ'D</u>	<u>PART NO.</u>	<u>DESCRIPTION</u>
4	100001	Spacer (.55" Wide)
4	100002	Spacer (1.09" Wide)
6	10053	.38" UNF X 2.50" Hex Capscrew - Grade 8
2	10054	.38" UNF X 3.25" Hex Capscrew - Grade 8
2	17024	Spacer
2	17016	Tooth Spacer
3	31592	Center Shark Style Tooth
1	53054	6" Crumber Shoe

New stations: (1) 6L-D (1) C-D (1) CR-D (1) CL-D Remove: (2) 8-C (2) 8-D

3) FROM 6" WIDE TO 10" WIDE (Kit #100018)

<u>REQ'D</u>	<u>PART NO.</u>	<u>DESCRIPTION</u>
8	1796	.38" UNF Lock Nut
1	31593	Left Shark Style Tooth
2	31594	Right Shark Style Tooth
2	31595	Left Cup Tooth
2	31596	Right Cup Tooth
8	10078	.38" UNF X 2.75" Hex Capscrew - Grade 8
2	17017	8" Tooth Spacer
8	10079	.38" UNF X 3.75" Hex Capscrew - Grade 8
2	17018	10" Tooth Spacer
1	53058	10" Crumber Shoe

New stations: (1) 8-C (1) 8-D (1) 10-C (1) 10-D Remove: (1) 6L-D (1) C-D (1) CR-D (1) CL-D

DIGGING CHAIN OPTIONS

1.654" PITCH DIGGING CHAIN WIDTH CONVERSIONS FOR 615 TRENCHER

4) FROM 10" WIDE TO 6" WIDE (Order seperately)

<u>REQ'D</u>	<u>PART NO.</u>	<u>DESCRIPTION</u>
4	100001	Spacer (.55" Wide)
4	100002	Spacer (1.09" Wide)
6	10053	.38" UNF X 2.50" Hex Capscrew - Grade 8
2	10054	.38" UNF X 3.25" Hex Capscrew - Grade 8
2	17024	Spacer
2	17016	Tooth Spacer
3	31592	Center Shark Style Tooth
1	53054	6" Crumber Shoe

New stations: (1) 6L-D (1) C-D (1) CR-D (1) CL-D Remove:(1) 8-C (1) 8-D (1) 10-C (1) 10-D

5) FROM 6" WIDE TO 12" WIDE (Kit #100019)

<u>REQ'D</u>	<u>PART NO.</u>	<u>DESCRIPTION</u>
12	1796	.38" UNF Lock Nut
2	31593	Left Shark Style Tooth
3	31594	Right Shark Style Tooth
3	31595	Left Cup Tooth
3	31596	Right Cup Tooth
8	10078	.38" UNF X 2.75" Hex Capscrew - Grade 8
2	17017	8" Tooth Spacer
8	10079	.38" UNF X 3.75" Hex Capscrew - Grade 8
2	17018	10" Tooth Spacer
4	10080	.38" UNF X 4.75" Hex Capscrew - Grade 8
4	10081	.38" UNF X 5.00" Hex Capscrew - Grade 8
2	17019	12" Tooth Spacer
1	53059	12" Crumber Shoe

New stations: (1) 8-C (1) 8-D (1) 10-C (1) 10-D (1) 12-C (1) 12-D Remove: (2) CR-D (2) CL-D (1) 6L-D (1) C-D

6) FROM 12" WIDE TO 6" WIDE (Order seperately)

<u>REQ'D</u>	<u>PART NO.</u>	<u>DESCRIPTION</u>
4	100001	Spacer (.55" Wide)
8	100002	Spacer (1.09" Wide)
10	10053	.38" UNF X 2.50" Hex Capscrew - Grade 8
2	10054	.38" UNF X 3.25" Hex Capscrew - Grade 8
2	17024	Spacer
2	17016	Tooth Spacer
5	31592	Center Shark Style Tooth
1	53054	6" Crumber Shoe

New stations: (2) CR-D (2) CL-D (1) 6L-D (1) C-D Remove: (1) 8-C (1) 8-D (1) 10-C (1) 10-D (1) 12-C (1) 12-D

7) FROM 8" WIDE TO 10" WIDE (Kit #100020)

<u>REQ'D</u>	<u>PART NO.</u>	<u>DESCRIPTION</u>
8	10079	.38" UNF X 3.75" Hex Capscrew - Grade 8
2	17018	10" Tooth Spacer
1	53058	10" Crumber Shoe

New stations: (1) 10-C (1) 10-D Remove: (1) 8-C (1) 8-D

8) FROM 10" WIDE TO 8" WIDE (Order seperately)

<u>REQ'D</u>	<u>PART NO.</u>	<u>DESCRIPTION</u>
8	10078	.38" UNF X 2.75" Hex Capscrew - Grade 8
2	17017	8" Tooth Spacer
1	53055	8" Crumber Shoe

New Stations: (1) 8-C (1) 8-D Remove: (1) 10-C (1) 10-D

DIGGING CHAIN OPTIONS

1.654" PITCH DIGGING CHAIN WIDTH CONVERSIONS FOR 615 TRENCHER

9) FROM 8" WIDE TO 12" WIDE (Kit #100021)

<u>REQ'D</u>	<u>PART NO.</u>	<u>DESCRIPTION</u>
4	1796	.38" UNF Lock Nut
1	31593	Left Shark Style Tooth
1	31594	Right Shark Style Tooth
1	31595	Left Cup Tooth
1	31596	Right Cup Tooth
8	10079	.38" UNF X 3.75" Hex Capscrew - Grade 8
2	17018	10" Tooth Spacer
4	10080	.38" UNF X 4.75" Hex Capscrew - Grade 8
4	10081	.38" UNF X 5.00" Hex Capscrew - Grade 8
2	17019	12" Tooth Spacer
1	53059	12" Crumber Shoe

New stations: (1) 10-C (1) 10-D (1) 12-C (1) 12-D Remove: (1) CR-D (1) CL-D (1) 8-D (1) 8-C

10) FROM 12" WIDE TO 8" WIDE (Order seperately)

<u>REQ'D</u>	<u>PART NO.</u>	<u>DESCRIPTION</u>
4	100002	Spacer (1.09" Wide)
4	10053	.38" UNF X 2.50" Hex Capscrew - Grade 8
2	31592	Center Shark Style Tooth
8	10078	.38" UNF X 2.75" Hex Capscrew - Grade 8
2	17017	8" Tooth Spacer
1	53055	8" Crumber Shoe

New stations: (1) CR-D (1) CL-D (1) 8-C (1) 8-D Remove: (1) 10-C (1) 10-D (1) 12-C (1) 12-D

11) FROM 10" WIDE TO 12" WIDE (Kit #100022)

<u>REQ'D</u>	<u>PART NO.</u>	<u>DESCRIPTION</u>
4	1796	.38" UNF Lock Nut
1	31593	Left Shark Style Tooth
1	31594	Right Shark Style Tooth
1	31595	Left Cup Tooth
1	31596	Right Cup Tooth
4	10080	.38" UNF X 4.75" Hex Capscrew - Grade 8
4	10081	.38" UNF X 5.00" Hex Capscrew - Grade 8
2	17019	12" Tooth Spacer
1	53059	12" Crumber Shoe

New stations: (1) 12-C (1) 12-D Remove: (1) CR-D (1) CL-D

12) FROM 12" WIDE TO 10" WIDE (Order seperately)

<u>REQ'D</u>	<u>PART NO.</u>	<u>DESCRIPTION</u>
4	100002	Spacer (1.09" Wide)
4	10053	.38" UNF X 2.50" Hex Capscrew - Grade 8
2	31592	Center Shark Style Tooth
1	53058	10" Crumber Shoe

New Stations: (1) CR-D (1) CL-D Remove: (1) 12-C (1) 12-D

DIGGING CHAIN OPTIONS

1.654" PITCH DIGGING CHAIN WIDTH CONVERSIONS FOR 615 TRENCHER

615 TRENCHER CHAIN CONVERSIONS FOR 30" BOOMS - 70/30 COMBINATION

1) FROM 6" WIDE TO 8" WIDE (Kit #100023)

REQ'D	PART NO.	DESCRIPTION
8	1796	.38" UNF Lock Nut
1	31593	Left Shark Style Tooth
1	31594	Right Shark Style Tooth
1	31595	Left Cup Tooth
1	31596	Right Cup Tooth
16	10078	.38" UNF X 2.75" Hex Capscrew - Grade 8
4	17017	8" Tooth Spacer
1	53055	8" Crumber Shoe

New stations: (2) 8-C (2) 8-D Remove: (1) 4R-D (1) 4R-C (1) 4L-D (1) 4L-C

2) FROM 8" WIDE TO 6" WIDE (Order seperately)

REQ'D	PART NO.	DESCRIPTION
8	10053	.38" UNF X 2.50" Hex Capscrew - Grade 8
8	17024	Spacer
1	53054	6" Crumber Shoe

New stations: (1) 4R-D (1) 4R-C (1) 4L-D (1) 4L-C Remove: (2) 8-C (2) 8-D

3) FROM 6" WIDE TO 10" WIDE (Kit #100024)

REQ'D	PART NO.	DESCRIPTION
14	1796	.38" UNF Lock Nut
3	31593	Left Shark Style Tooth
3	31594	Right Shark Style Tooth
2	31595	Left Cup Tooth
2	31596	Right Cup Tooth
12	10078	.38" UNF X 2.75" Hex Capscrew - Grade 8
3	17017	8" Tooth Spacer
16	10079	.38" UNF X 3.75" Hex Capscrew - Grade 8
4	17018	10" Tooth Spacer
1	53058	10" Crumber Shoe

New stations:(1) 8-C (2) 8-D (2) 10-D (2) 10-C Remove: (1) 4R-D (1) 4R-C (1) 4L-D (1) 4L-C (1) C-D (1) CR-D (1) CL-D

4) FROM 10" WIDE TO 6" WIDE (Order seperately)

REQ'D	PART NO.	DESCRIPTION
4	100001	Spacer (.55" Wide)
4	100002	Spacer (1.09" Wide)
14	10053	.38" UNF X 2.50" Hex Capscrew - Grade 8
8	17024	Spacer
3	31592	Center Shark Style Tooth
1	53054	6" Crumber Shoe

New stations:(1) 4R-D (1) 4R-C (1) 4L-D (1) 4L-C (1) C-D (1) CR-D (1) CL-D Remove: (1) 8-C (2) 8-D (2) 10-D (2) 10-C

5) FROM 8" WIDE TO 10" WIDE (Kit #100025)

REQ'D	PART NO.	DESCRIPTION
6	1796	.38" UNF Lock Nut
2	31593	Left Shark Style Tooth
2	31594	Right Shark Style Tooth
1	31595	Left Cup Tooth
1	31596	Right Cup Tooth
16	10079	.38" UNF X 3.75" Hex Capscrew - Grade 8
4	17018	10" Tooth Spacer
1	53058	10" Crumber Shoe

New stations: (2) 10-C (2) 10-D Remove: (1) C-D (1) CR-D (1) CL-D (1) 8-C

DIGGING CHAIN OPTIONS

1.654" PITCH DIGGING CHAIN WIDTH CONVERSIONS FOR 615 TRENCHER

6) FROM 10" WIDE TO 8" WIDE (Order seperately)

<u>REQ'D</u>	<u>PART NO.</u>	<u>DESCRIPTION</u>
4	100001	Spacer (.55" Wide)
4	100002	Spacer (1.09" Wide)
6	10053	.38" UNF X 2.50" Hex Capscrew - Grade 8
3	31592	Center Shark Style Tooth
4	10078	.38" UNF X 2.75" Hex Capscrew - Grade 8
1	17017	8" Tooth Spacer
1	53055	8" Crumber Shoe

New Stations: (1) C-D (1) CR-D (1) CL-D (1) 8-C Remove: (2) 10-C (2) 10-D

615 TRENCHER CHAIN CONVERSIONS FOR 36" BOOMS - 70/30 COMBINATION

1) FROM 4.50" WIDE TO 6" WIDE (Kit #100026)

<u>REQ'D</u>	<u>PART NO.</u>	<u>DESCRIPTION</u>
12	17024	Spacer
2	31593	Left Shark Style Tooth
1	31594	Right Shark Style Tooth
1	31595	Left Cup Tooth
2	31596	Right Cup Tooth
22	10054	.38" UNF X 3.25" Hex Capscrew - Grade 8
22	17016	Tooth Spacer
1	53054	6" Crumber Shoe

New stations:(3) 6R-D (3) 6R-C (3) 6L-D (2) 6L-C Remove: (2) C-D (2) CR-D (2) CL-D (2) 4R-D (1) 4R-C (1) 4L-D
(1) 4L-C

2) FROM 6" WIDE TO 4.50" WIDE (Order seperately)

<u>REQ'D</u>	<u>PART NO.</u>	<u>DESCRIPTION</u>
8	100001	Spacer (.55" Wide)
8	100002	Spacer (1.09" Wide)
22	10053	.38" UNF X 2.50" Hex Capscrew - Grade 8
6	31592	Center Shark Style Tooth
1	59808	4.5" Crumber Shoe

New stations:(2) C-D (2) CR-D (2) CL-D (2) 4R-D (1) 4R-C (1) 4L-D (1) 4L-C Remove: (3) 6R-D (3) 6R-C (3) 6L-D
(2) 6L-C

3) FROM 4.50" WIDE TO 8" WIDE (Kit #100027)

<u>REQ'D</u>	<u>PART NO.</u>	<u>DESCRIPTION</u>
12	1796	.38" UNF Lock Nut
5	31593	Left Shark Style Tooth
4	31594	Right Shark Style Tooth
1	31595	Left Cup Tooth
2	31596	Right Cup Tooth
16	10054	.38" UNF X 3.25" Hex Capscrew - Grade 8
16	17016	Tooth Spacer
24	10078	.38" UNF X 2.75" Hex Capscrew - Grade 8
6	17017	8" Tooth Spacer
1	53055	8" Crumber Shoe

New stations: (3) 6R-D (1) 6R-C (3) 6L-D (1) 6L-C (3) 8-D (3) 8-C Remove: (2) C-D (2) CR-D (2) CL-D (2) 4R-D
(2) 4R-C (1) 4L-D (3) 4L-C

DIGGING CHAIN OPTIONS

1.654" PITCH DIGGING CHAIN WIDTH CONVERSIONS FOR 615 TRENCHER

4) FROM 8" WIDE TO 4.50" WIDE (Order seperately)

<u>REQ'D</u>	<u>PART NO.</u>	<u>DESCRIPTION</u>
8	100001	Spacer (.55" Wide)
8	100002	Spacer (1.09" Wide)
28	10053	.38" UNF X 2.50" Hex Capscrew - Grade 8
6	31592	Center Shark Style Tooth
1	59808	4.5" Crumber Shoe

New stations: (2) C-D (2) CR-D (2) CL-D (2) 4R-D (2) 4R-C (1) 4L-D (3) 4L-C Remove: (3) 6R-D (1) 6R-C (3) 6L-D
(1) 6L-C (3) 8-D (3) 8-C

5) FROM 6" WIDE TO 8" WIDE (Kit #100028)

<u>REQ'D</u>	<u>PART NO.</u>	<u>DESCRIPTION</u>
12	1796	.38" UNF Lock Nut
3	31593	Left Shark Style Tooth
3	31594	Right Shark Style Tooth
24	10078	.38" UNF X 2.75" Hex Capscrew - Grade 8
6	17017	8" Tooth Spacer
1	53055	8" Crumber Shoe

New stations: (3) 8-D (3) 8-C Remove: (1) 6L-C (2) 6R-C (1) 4R-C (2) 4L-C

6) FROM 8" WIDE TO 6" WIDE (Order seperately)

<u>REQ'D</u>	<u>PART NO.</u>	<u>DESCRIPTION</u>
6	10053	.38" UNF X 2.50" Hex Capscrew - Grade 8
12	17024	Spacer
6	10054	.38" UNF X 3.25" Hex Capscrew - Grade 8
6	17016	Tooth Spacer
1	53054	6" Crumber Shoe

New Stations: (1) 6L-C (2) 6R-C (1) 4R-C (2) 4L-C Remove: (3) 8-D (3) 8-C

615 TRENCHER CHAIN CONVERSIONS FOR 48" BOOMS - 70/30 COMBINATION

1) FROM 4.50" WIDE TO 6" WIDE (Kit #100029)

<u>REQ'D</u>	<u>PART NO.</u>	<u>DESCRIPTION</u>
1	31593	Left Shark Style Tooth
2	31594	Right Shark Style Tooth
2	31595	Left Cup Tooth
1	31596	Right Cup Tooth
12	17024	Spacer
26	10054	.38" UNF X 3.25" Hex Capscrew - Grade 8
26	17016	Tooth Spacer
1	53054	6" Crumber Shoe

New stations:(4) 6R-D (3) 6R-C (3) 6L-D (3) 6L-C Remove: (2) C-D (2) CR-D (2) CL-D (2) 4R-D (2) 4R-C (2) 4L-D
(1) 4L-C

2) FROM 6" WIDE TO 4.50" WIDE (Order seperately)

<u>REQ'D</u>	<u>PART NO.</u>	<u>DESCRIPTION</u>
8	100001	Spacer (.55" Wide)
8	100002	Spacer (1.09" Wide)
26	10053	.38" UNF X 2.50" Hex Capscrew - Grade 8
6	31592	Center Shark Style Tooth
1	59808	4.5" Crumber Shoe

New stations: (2) C-D (2) CR-D (2) CL-D (2) 4R-D (2) 4R-C (2) 4L-D (1) 4L-C Remove: (4) 6R-D (3) 6R-C (3) 6L-D
(3) 6L-C

DIGGING CHAIN OPTIONS

1.654" PITCH DIGGING CHAIN WIDTH CONVERSIONS FOR 615F FOOTING TRENCHER

615F TRENCHER CHAIN CONVERSIONS FOR 24" BOOMS - CUP TEETH

1) FROM 6" WIDE TO 8" WIDE (Kit #17091)

<u>REQ'D</u>	<u>PART NO.</u>	<u>DESCRIPTION</u>
10	1796	.38" UNF Lock Nut
1	31595	Left Cup Tooth
4	31596	Right Cup Tooth
20	10078	.38" UNF X 2.75" Hex Capscrew - Grade 8
5	17017	8" Tooth Spacer
1	53055	8" Crumber Shoe

New stations: (5) 8-C Remove: (1) 6L-C (1) 6R-C (1) CL-C (2) 4L-C

2) FROM 8" WIDE TO 6" WIDE (Order seperately)

<u>REQ'D</u>	<u>PART NO.</u>	<u>DESCRIPTION</u>
6	10053	.38" UNF X 2.50" Hex Capscrew - Grade 8
10	17024	Spacer
4	10054	.38" UNF X 3.25" Hex Capscrew - Grade 8
4	17016	Tooth Spacer
1	53054	6" Crumber Shoe

New Stations: (1) 6L-C (1) 6R-C (1) CL-C (2) 4L-C Remove: (5) 8-C

3) FROM 6" WIDE TO 10" WIDE (Kit #100031)

<u>REQ'D</u>	<u>PART NO.</u>	<u>DESCRIPTION</u>
16	1796	.38" UNF Lock Nut
4	31595	Left Cup Tooth
4	31596	Right Cup Tooth
16	10078	.38" UNF X 2.75" Hex Capscrew - Grade 8
4	17017	8" Tooth Spacer
16	10079	.38" UNF X 3.75" Hex Capscrew - Grade 8
4	17018	10" Tooth Spacer
1	53058	10" Crumber Shoe

New stations: (4) 8-C (4) 10-C Remove: (1) 6L-C (2) 6R-C (1) 4R-C (2) 4L-C (1) CR-C (1) CL-C

4) FROM 10" WIDE TO 6" WIDE (Order seperately)

<u>REQ'D</u>	<u>PART NO.</u>	<u>DESCRIPTION</u>
10	10053	.38" UNF X 2.50" Hex Capscrew - Grade 8
6	10054	.38" UNC X 3.25" Hex Capscrew - Grade 8
16	17024	Spacer
6	17016	Tooth Spacer
1	53054	6" Crumber Shoe

New Stations: (1) 6L-C (2) 6R-C (1) 4R-C (2) 4L-C (1) CR-C (1) CL-C Remove: (4) 8-C (4) 10-C

5) FROM 6" WIDE TO 12" WIDE (Kit #100032)

<u>REQ'D</u>	<u>PART NO.</u>	<u>DESCRIPTION</u>
24	1796	.38" UNF Lock Nut
5	31595	Left Cup Tooth
7	31596	Right Cup Tooth
4	17017	8" Tooth Spacer
16	10078	.38" UNF X 2.75" Hex Capscrew - Grade 8
16	10079	.38" UNF X 3.75" Hex Capscrew - Grade 8
4	17018	10" Tooth Spacer
16	10080	.38" UNF X 4.75" Hex Capscrew - Grade 8
4	17019	12" Tooth Spacer
1	53059	12" Crumber Shoe

New stations: (4) 8-C (4) 10-C (4) 12-C Remove: (2) CL-C (3) 4L-C (2) 4R-C (2) 6L-C (2) 6R-C (1) CR-C

DIGGING CHAIN OPTIONS

1.654" PITCH DIGGING CHAIN WIDTH CONVERSIONS FOR 615F FOOTING TRENCHER

6) FROM 12" WIDE TO 6" WIDE (Order seperately)

<u>REQ'D</u>	<u>PART NO.</u>	<u>DESCRIPTION</u>
16	10053	.38" UNF X 2.50" Hex Capscrew - Grade 8
8	10054	.38" UNF X 3.25" Hex Capscrew - Grade 8
24	17024	Spacer
8	17016	Tooth Spacer
1	53054	6" Crumber Shoe

New Stations: (2) CL-C (3) 4L-C (2) 4R-C (2) 6L-C (2) 6R-C (1) CR-C Remove: (4) 8-C (4) 10-C (4) 12-C

7) FROM 8" WIDE TO 10" WIDE (Kit #100033)

<u>REQ'D</u>	<u>PART NO.</u>	<u>DESCRIPTION</u>
6	1796	.38" UNF Lock Nut
3	31595	Left Cup Tooth
16	10079	.38" UNF X 3.75" Hex Capscrew - Grade 8
4	17018	10" Tooth Spacer
1	53058	10" Crumber Shoe

New stations: (4) 10-C Remove: (1) 6R-C (1) 8-C (1) CR-C (1) 4R-C

8) FROM 10" WIDE TO 8" WIDE (Order seperately)

<u>REQ'D</u>	<u>PART NO.</u>	<u>DESCRIPTION</u>
4	10053	.38" UNF X 2.50" Hex Capscrew - Grade 8
2	10054	.38" UNF X 3.25" Hex Capscrew - Grade 8
6	17024	Spacer
4	10078	.38" UNF X 2.75" Hex Capscrew - Grade 8
2	17016	Tooth Spacer
1	17017	8" Tooth Spacer
1	53055	8" Crumber Shoe

New Stations: (1) 6R-C (1) 8-C (1) CR-C(1) 4R-C Remove: (4) 10-C

9) FROM 8" WIDE TO 12" WIDE (Kit #100034)

<u>REQ'D</u>	<u>PART NO.</u>	<u>DESCRIPTION</u>
14	1796	.38" UNF Lock Nut
4	31595	Left Cup Tooth
3	31596	Right Cup Tooth
16	10079	.38" UNF X 3.75" Hex Capscrew - Grade 8
4	17018	10" Tooth Spacer
16	10080	.38" UNF X 4.75" Hex Capscrew - Grade 8
4	17019	12" Tooth Spacer
1	53059	12" Crumber Shoe

New stations: (4) 12-C (4) 10-C Remove: (2) 4R-C (1) CL-C (1) 4L-C (1) 6L-C (1) 6R-C (1) 8-C (1) CR-C

10) FROM 12" WIDE TO 8" WIDE (Order seperately)

<u>REQ'D</u>	<u>PART NO.</u>	<u>DESCRIPTION</u>
10	10053	.38" UNF X 2.50" Hex Capscrew - Grade 8
4	10054	.38" UNF X 3.25" Hex Capscrew - Grade 8
14	17024	Spacer
4	17016	Tooth Spacer
4	10078	.38" UNF X 2.75" Hex Capscrew - Grade 8
1	17017	8" Tooth Spacer
1	53055	8" Crumber Shoe

New Stations: (2) 4R-C (1) CL-C (1) 4L-C (1) 6L-C (1) 6R-C (1) 8-C (1) CR-C Remove: (4) 12-C (4) 10-C

DIGGING CHAIN OPTIONS

1.654" PITCH DIGGING CHAIN WIDTH CONVERSIONS FOR 615F FOOTING TRENCHER

11) FROM 10" WIDE TO 12" WIDE (Kit #10035)

<u>REQ'D</u>	<u>PART NO.</u>	<u>DESCRIPTION</u>
8	1796	.38" UNF Lock Nut
1	31595	Left Cup Tooth
3	31596	Right Cup Tooth
16	10080	.38" UNF X 4.75" Hex Capscrew - Grade 8
4	17019	12" Tooth Spacer
1	53059	12" Crumber Shoe

New stations: (4) 12-C Remove: (1) CL-C (1) 4L-C (1) 4R-C (1) 6L-C

12) FROM 12" WIDE TO 10" WIDE (Order seperately)

<u>REQ'D</u>	<u>PART NO.</u>	<u>DESCRIPTION</u>
6	10053	.38" UNF X 2.50" Hex Capscrew - Grade 8
2	10054	.38" UNF X 3.25" Hex Capscrew - Grade 8
8	17024	Spacer
2	17016	Tooth Spacer
1	53058	10" Crumber Shoe

New Stations: (1) CL-C (1) 4L-C (1) 4R-C (1) 6L-C Remove: (4) 12-C

615F TRENCHER CHAIN CONVERSIONS FOR 30" BOOMS - CUP TEETH

1) FROM 6" WIDE TO 8" WIDE (Kit #100036)

<u>REQ'D</u>	<u>PART NO.</u>	<u>DESCRIPTION</u>
12	1796	.38" UNF Lock Nut
3	31595	Left Cup Tooth
3	31596	Right Cup Tooth
24	10078	.38" UNF X 2.75" Hex Capscrew - Grade 8
6	17017	8" Tooth Spacer
1	53055	8" Crumber Shoe

New stations: (6) 8-C Remove: (1) CL-C (1) 4L-C (1) 6L-C (1) 6R-C (1) CR-C (1) 4R-C

2) FROM 8" WIDE TO 6" WIDE (Order seperately)

<u>REQ'D</u>	<u>PART NO.</u>	<u>DESCRIPTION</u>
6	10053	.38" UNF X 2.50" Hex Capscrew - Grade 8
4	10054	.38" UNF X 3.25" Hex Capscrew - Grade 8
5	1525	.38" Flat Washer
4	17016	Tooth Spacer
1	53054	6" Crumber Shoe

New Stations: (1) CL-C (1) 4L-C (1) 6L-C (1) 6R-C (1) CR-C (1) 4R-C Remove: (6) 8-C

3) FROM 6" WIDE TO 10" WIDE (Kit #100037)

<u>REQ'D</u>	<u>PART NO.</u>	<u>DESCRIPTION</u>
20	1796	.38" UNF Lock Nut
5	31595	Left Cup Tooth
5	31596	Right Cup Tooth
20	10078	.38" UNF X 2.75" Hex Capscrew - Grade 8
5	17017	8" Tooth Spacer
20	10079	.38" UNF X 3.75" Hex Capscrew - Grade 8
5	17018	10" Tooth Spacer
1	53058	10" Crumber Shoe

New stations: (5) 8-C (5) 10-C Remove: (2) 4L-C (2) 4R-C (2) 6L-C (2) 6R-C (1) CL-C (1) CR-C

DIGGING CHAIN OPTIONS

1.654" PITCH DIGGING CHAIN WIDTH CONVERSIONS FOR 615F FOOTING TRENCHER

4) FROM 10" WIDE TO 6" WIDE (Order seperately)

<u>REQ'D</u>	<u>PART NO.</u>	<u>DESCRIPTION</u>
12	10053	.38" UNF X 2.50" Hex Capscrew - Grade 8
8	10054	.38" UNF X 3.25" Hex Capscrew - Grade 8
20	17024	Spacer
8	17016	Tooth Spacer
1	53054	6" Crumber Shoe

New Stations: (2) 4L-C(2) 4R-C (2) 6L-C (2) 6R-C (1) CL-C (1) CR-C Remove: (5) 8-C (5) 10-C

5) FROM 8" WIDE TO 10" WIDE (Kit #100038)

<u>REQ'D</u>	<u>PART NO.</u>	<u>DESCRIPTION</u>
8	1796	.38" UNF Lock Nut
2	31596	Right Cup Tooth
2	31595	Left Cup Tooth
20	10079	.38" UNF X 3.75" Hex Capscrew - Grade 8
5	17018	10" Tooth Spacer
1	53058	10" Crumber Shoe

New stations: (5) 10-C Remove: (1) 4R-C (1) 4L-C (1) 6L-C (1) 6R-C (1) 8-C

6) FROM 10" WIDE TO 8" WIDE (Order seperately)

<u>REQ'D</u>	<u>PART NO.</u>	<u>DESCRIPTION</u>
6	10053	.38" UNF X 2.50" Hex Capscrew - Grade 8
4	10054	.38" UNF X 3.25" Hex Capscrew - Grade 8
5	1525	.38" Flat Washer
4	17016	Tooth Spacer
1	53055	8" Crumber Shoe

New Stations: (1) 4R-C (1) 4L-C (1) 6L-C (1) 6R-C (1) 8-C Remove: (5) 10-C

615F TRENCHER CHAIN CONVERSIONS FOR 24" BOOMS - 70/30 COMBINATION

1) FROM 6" WIDE TO 8" WIDE (Kit #100028)

<u>REQ'D</u>	<u>PART NO.</u>	<u>DESCRIPTION</u>
12	1796	.38" UNF Lock Nut
3	31593	Left Shark Style Tooth
3	31594	Right Shark Style Tooth
24	10078	.38" UNF X 2.75" Hex Capscrew - Grade 8
6	17017	8" Tooth Spacer
1	53055	8" Crumber Shoe

New stations: (3) 8-D (3) 8-C Remove: (1) 6L-C (2) 6R-C (1) 4R-C (2) 4L-C

2) FROM 8" WIDE TO 6" WIDE (Order seperately)

<u>REQ'D</u>	<u>PART NO.</u>	<u>DESCRIPTION</u>
6	10053	.38" UNF X 2.50" Hex Capscrew - Grade 8
12	17024	Spacer
6	10054	.38" UNF X 3.25" Hex Capscrew - Grade 8
6	17016	Tooth Spacer
1	53054	6" Crumber Shoe

New Stations: (1) 6L-C (2) 6R-C (1) 4R-C (2) 4L-C Remove: (3) 8-D (3) 8-C

DIGGING CHAIN OPTIONS

1.654" PITCH DIGGING CHAIN WIDTH CONVERSIONS FOR 615F FOOTING TRENCHER

3) FROM 6" WIDE TO 10" WIDE (Kit #100040)

<u>REQ'D</u>	<u>PART NO.</u>	<u>DESCRIPTION</u>
16	1796	.38" UNF Lock Nut
2	31593	Left Shark Style Tooth
2	31594	Right Shark Style Tooth
3	31595	Left Cup Tooth
2	31596	Right Cup Tooth
16	10078	.38" UNF X 2.75" Hex Capscrew - Grade 8
4	17017	8" Tooth Spacer
16	10079	.38" UNF X 3.75" Hex Capscrew - Grade 8
4	17018	10" Tooth Spacer
1	53058	10" Crumber Shoe

New stations: (2) 8-D (2) 8-C (2) 10-D (2) 10-C

Remove: (1) 4L-D (1) 4L-C (1) 4R-D (1) 4R-C (1) C-D (1) 6R-D (1) 6R-C (1) 6L-D

4) FROM 10" WIDE TO 6" WIDE (Order seperately)

<u>REQ'D</u>	<u>PART NO.</u>	<u>DESCRIPTION</u>
4	100001	Spacer (.55" Wide)
14	17024	Spacer
10	10053	.38" UNF X 2.50" Hex Capscrew - Grade 8
6	10054	.38" UNF X 3.25" Hex Capscrew - Grade 8
6	17016	Tooth Spacer
1	31592	Center Shark Style Tooth
1	53054	6" Crumber Shoe

New Stations: (1) 4L-D (1) 4L-C (1) 4R-D (1) 4R-C (1) C-D (1) 6R-D (1) 6R-C (1) 6L-D

Remove: (2) 8-D (2) 8-C (2) 10-D (2) 10-C

5) FROM 6" WIDE TO 12" WIDE (Kit #100041)

<u>REQ'D</u>	<u>PART NO.</u>	<u>DESCRIPTION</u>
18	1796	.38" UNF Lock Nut
4	31593	Left Shark Style Tooth
5	31594	Right Shark Style Tooth
3	31595	Left Cup Tooth
2	31596	Right Cup Tooth
12	10078	.38" UNF X 2.75" Hex Capscrew - Grade 8
3	17017	8" Tooth Spacer
12	10079	.38" UNF X 3.75" Hex Capscrew - Grade 8
3	17018	10" Tooth Spacer
4	10080	.38" UNF X 4.75" Hex Capscrew - Grade 8
8	10081	.38" UNF X 5.00" Hex Capscrew - Grade 8
3	17019	12" Tooth Spacer
1	53059	12" Crumber Shoe

New stations: (2) 8-D (1) 8-C (1) 10-D (2) 10-C (2) 12-D (1) 12-C

Remove: (2) CD-R (2) CL-D (1) 6L-C (1) C-D (1) 4R-C (1) 4L-C (1) 6R-C

DIGGING CHAIN OPTIONS

1.654" PITCH DIGGING CHAIN WIDTH CONVERSIONS FOR 615F FOOTING TRENCHER

6) FROM 12" WIDE TO 6" WIDE (Order seperately)

<u>REQ'D</u>	<u>PART NO.</u>	<u>DESCRIPTION</u>
4	100001	Spacer (.55" Wide)
8	100002	Spacer (1.09" Wide)
14	10053	.38" UNF X 2.50" Hex Capscrew - Grade 8
4	10054	.38" UNF X 3.25" Hex Capscrew - Grade 8
8	17024	Spacer
4	17016	Tooth Spacer
5	31592	Center Shark Style Tooth
1	53054	6" Crumber Shoe

New Stations: (2) CD-R (2) CL-D (1) 6L-C (1) C-D (1) 4R-C (1) 4L-C (1) 6R-C Remove: (2) 8-D (1) 8-C (1) 10-D (2) 10-C (2) 12-D (1) 12-C

7) FROM 8" WIDE TO 10" WIDE (Kit #100042)

<u>REQ'D</u>	<u>PART NO.</u>	<u>DESCRIPTION</u>
4	1796	.38" UNF Lock Nut
3	31595	Left Cup Tooth
2	31596	Right Cup Tooth
16	10079	.38" UNF X 3.75" Hex Capscrew - Grade 8
4	17018	10" Tooth Spacer
1	53058	10" Crumber Shoe

New stations: (1) 4L-C (1) 6R-C (1) 6L-C (2) 10-D (2) 10-C Remove: (1) 4L-D (1) 8-D (1) 4R-D (1) 8-C (1) C-D (1) 6R-D (1) 6L-D

8) FROM 10" WIDE TO 8" WIDE (Order seperately)

<u>REQ'D</u>	<u>PART NO.</u>	<u>DESCRIPTION</u>
4	100001	Spacer (.55" Wide)
2	17024	Spacer
4	10053	.38" UNF X 2.50" Hex Capscrew - Grade 8
1	31592	Center Shark Style Tooth
1	31593	Left Shark Style Tooth
1	31594	Right Shark Style Tooth
8	10078	.38" UNF X 2.75" Hex Capscrew - Grade 8
2	17017	8" Tooth Spacer
1	53055	8" Crumber Shoe

New Stations: (1) 4L-D (1) 8-D (1) 4R-D (1) 8-C (1) C-D (1) 6R-D (1) 6L-D Remove: (1) 4L-C (1) 6R-C (1) 6L-C (2) 10-D (2) 10-C

9) FROM 8" WIDE TO 12" WIDE (Kit #100043)

<u>REQ'D</u>	<u>PART NO.</u>	<u>DESCRIPTION</u>
2	10054	.38" UNF X 3.25" Hex Capscrew - Grade 8
2	17016	Tooth Spacer
4	17024	Spacer
6	1796	.38" UNF Lock Nut
1	31593	Left Shark Style Tooth
2	31594	Right Shark Style Tooth
3	31595	Left Cup Tooth
2	31596	Right Cup Tooth
12	10079	.38" UNF X 3.75" Hex Capscrew - Grade 8
3	17018	10" Tooth Spacer
4	10080	.38" UNF X 4.75" Hex Capscrew - Grade 8
8	10081	.38" UNF X 5.00" Hex Capscrew - Grade 8
3	17019	12" Tooth Spacer
1	53059	12" Crumber Shoe

New stations: (1) 4LC (1) 6RC (1) 6LC (1) 10-D (1) 12-C (2) 12-D (2) 10-C Remove: (2) CR-D (2) CL-D (2) 8-C (1) C-D (1) 8-D (1) 6LD

DIGGING CHAIN OPTIONS

1.654" PITCH DIGGING CHAIN WIDTH CONVERSIONS FOR 615F FOOTING TRENCHER

10) FROM 12" WIDE TO 8" WIDE (Order seperately)

<u>REQ'D</u>	<u>PART NO.</u>	<u>DESCRIPTION</u>
4	100001	Spacer (.55" Wide)
8	100002	Spacer (1.09" Wide)
8	10053	.38" UNF X 2.50" Hex Capscrew - Grade 8
5	31592	Center Shark Style Tooth
12	10078	.38" UNF X 2.75" Hex Capscrew - Grade 8
3	17017	8" Tooth Spacer
1	53055	8" Crumber Shoe

New Stations: (2) CR-D (2) CL-D (2) 8-C (1) C-D (1) 8-D (1) 6LD Remove: (1) 4LC (1) 6RC (1) 10-D (1) 12-C (2) 12-D (2) 10-C (1) 6LC

11) FROM 10" WIDE TO 12" WIDE (Kit #100044)

<u>REQ'D</u>	<u>PART NO.</u>	<u>DESCRIPTION</u>
2	10054	.38" UNF X 3.25" Hex Capscrew - Grade 8
2	17016	Tooth Spacer
6	17024	Spacer
2	1796	.38" UNF Lock Nut
2	31593	Left Shark Style Tooth
3	31594	Right Shark Style Tooth
4	10080	.38" UNF X 4.75" Hex Capscrew - Grade 8
8	10081	.38" UNF X 5.00" Hex Capscrew - Grade 8
3	17019	12" Tooth Spacer
1	53059	12" Crumber Shoe

New stations: (2) 12-D (1) 12-C (1) 4R-D (1) 4L-D (1) 6R-D Remove: (2) CR-D (2) CL-D (1) 8-C (1) 10-D

12) FROM 12" WIDE TO 10" WIDE (Order seperately)

<u>REQ'D</u>	<u>PART NO.</u>	<u>DESCRIPTION</u>
8	100002	Spacer (1.09" Wide)
4	10053	.38" UNF X 2.50" Hex Capscrew - Grade 8
4	31592	Center Shark Style Tooth
4	10078	.38" UNF X 2.75" Hex Capscrew - Grade 8
1	17017	8" Tooth Spacer
4	10079	.38" UNF X 3.75" Hex Capscrew - Grade 8
1	17018	10" Tooth Spacer
1	53058	10" Crumber Shoe

New Stations: (2) CR-D (2) CL-D (1) 8-C (1) 10-D Remove: (2) 12-D (1) 12-C (1) 4R-D (1) 4L-D (1) 6R-D

615F TRENCHER CHAIN CONVERSIONS FOR 30" BOOMS - 70/30 COMBINATION

1) FROM 6" WIDE TO 8" WIDE (Kit #100045)

<u>REQ'D</u>	<u>PART NO.</u>	<u>DESCRIPTION</u>
12	1796	.38" UNF Lock Nut
2	31593	Left Shark Style Tooth
1	31594	Right Shark Style Tooth
2	31595	Left Cup Tooth
1	31596	Right Cup Tooth
24	10078	.38" UNF X 2.75" Hex Capscrew - Grade 8
6	17017	8" Tooth Spacer
1	53055	8" Crumber Shoe

New stations: (3) 8-D (3) 8-C (1) 6L-C Remove: (1) 6R-C (1) 4R-C (1) 4L-D (2) 4L-C (2) 4R-D

2) FROM 8" WIDE TO 6" WIDE (Order seperately)

<u>REQ'D</u>	<u>PART NO.</u>	<u>DESCRIPTION</u>
12	10053	.38" UNF X 2.50" Hex Capscrew - Grade 8
12	17024	Spacer
1	53054	6" Crumber Shoe

New Stations: (1) 6R-C (1) 4R-C (1) 4L-D (2) 4L-C (2) 4R-D Remove: (3) 8-D (3) 8-C (1) 6L-C

DIGGING CHAIN OPTIONS

1.654" PITCH DIGGING CHAIN WIDTH CONVERSIONS FOR 615F FOOTING TRENCHER

3) FROM 6" WIDE TO 10" WIDE (Kit #100046)

<u>REQ'D</u>	<u>PART NO.</u>	<u>DESCRIPTION</u>
18	1796	.38" UNF Lock Nut
3	31593	Left Shark Style Tooth
3	31594	Right Shark Style Tooth
3	31595	Left Cup Tooth
2	31596	Right Cup Tooth
16	10078	.38" UNF X 2.75" Hex Capscrew - Grade 8
4	17017	8" Tooth Spacer
20	10079	.38" UNF X 3.75" Hex Capscrew - Grade 8
5	17018	10" Tooth Spacer
1	53058	10" Crumber Shoe

New stations: (3) 8-D (1) 8-C (2) 10-D (3) 10-C (1) 6L-C Remove: (1) C-D (1) CR-D (2) 4R-C (2) 4L-C (1) 6R-D (1) 6L-D (1) 4R-D (1) 4L-D

4) FROM 10" WIDE TO 6" WIDE (Order seperately)

<u>REQ'D</u>	<u>PART NO.</u>	<u>DESCRIPTION</u>
4	100001	Spacer (.55" Wide)
2	100002	Spacer (1.09" Wide)
16	10053	.38" UNF X 2.50" Hex Capscrew - Grade 8
2	10054	.38" UNF X 3.25" Hex Capscrew - Grade 8
14	17024	Spacer
2	17016	Tooth Spacer
2	31592	Center Shark Style Tooth
1	53054	6" Crumber Shoe

New Stations: (1) C-D (1) CR-D (2) 4R-C (2) 4L-C (1) 6R-D (1) 6L-D (1) 4R-D (1) 4L-D Remove: (3) 8-D (1) 8-C (2) 10-D (3) 10-C (1) 6L-C

5) FROM 8" WIDE TO 10" WIDE (Kit #100047)

<u>REQ'D</u>	<u>PART NO.</u>	<u>DESCRIPTION</u>
6	1796	.38" UNF Lock Nut
1	31593	Left Shark Style Tooth
2	31594	Right Shark Style Tooth
1	31595	Left Cup Tooth
1	31596	Right Cup Tooth
20	10079	.38" UNF X 3.75" Hex Capscrew - Grade 8
5	17018	10" Tooth Spacer
1	53058	10" Crumber Shoe

New stations: (2) 10-D (3) 10-C (1) 4R-D (1) 6R-C Remove: (2) 8-C (1) C-D (1) CR-D (1) 4R-C (1) 6R-D (1) 6L-D

6) FROM 10" WIDE TO 8" WIDE (Order seperately)

<u>REQ'D</u>	<u>PART NO.</u>	<u>DESCRIPTION</u>
4	100001	Spacer (.55" Wide)
2	100002	Spacer (1.09" Wide)
4	10053	.38" UNF X 2.50" Hex Capscrew - Grade 8
2	10054	.38" UNF X 3.25" Hex Capscrew - Grade 8
2	17024	Spacer
2	17016	Tooth Spacer
2	31592	Center Shark Style Tooth
8	10078	.38" UNF X 2.75" Hex Capscrew - Grade 8
2	17017	8" Tooth Spacer
1	53055	8" Crumber Shoe

New Stations: (2) 8-C (1) C-D (1) CR-D (1) 4R-C (1) 6R-D (1) 6L-D Remove: (2) 10-D (3) 10-C (1) 4R-D (1) 6R-C

MAINTENANCE

615 TRENCHER

GENERAL INFORMATION

Your trencher was designed to be virtually maintenance free. Very little effort is needed to keep it in top condition. It is, however, important to follow these procedures to get full performance and longevity out of the trencher.

LUBRICATION

Not all trenchers require lubricating of the headshaft bearing. The 615 trencher has a sealed bearing that requires no maintenance.

IMPORTANT: DO NOT lubricate any other part of the trencher! Lubricating parts such as the digging chain or the idler wheel will only attract dirt, resulting in increased wear.

8 HOURS OF OPERATION

Every 8 hours of operation the trencher should be inspected for loose nuts, capscrews, bearings etc. Tighten as required, replace where necessary. Clean equipment of all dirt, oil, grease, etc. This will assist you in making visual inspections and help avoid overlooking worn or damaged components. Keep all safety decals clean and legible. Replace if damaged or worn.

DIGGING TOOTH REPLACEMENT

Sharp teeth are important to good performance. When teeth wear out, production will drop sharply, increasing wear and tear on other components.

Cup teeth wear on the tip and side bulge in varying amounts. Wear patterns change with different digging conditions. The following patterns and captions approximate, and should be used as a guide to help you determine your own best cost/benefit tooth replacement time. Normal replacement should be made between 30% and 60% reduction in performance. Replacement is a bolt-on procedure (See Section J).

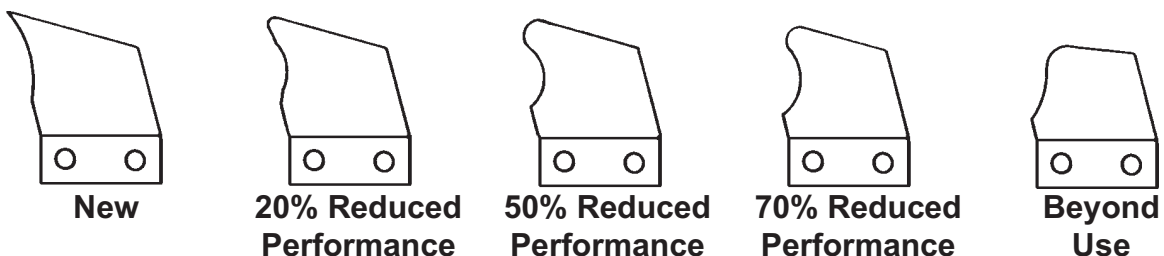

STORAGE

615 TRENCHER

GENERAL INFORMATION

The following storage procedures will help you to keep your trencher in top condition. They will also help you get off to a good start the next time your trencher is needed. We therefore, strongly recommend that you take the extra time to follow these procedures whenever your trencher will not be used for an extended period of time.

PREPARATION FOR STORAGE

1. Clean the trencher exterior thoroughly, removing all mud, dirt, and grease.
2. Tighten all loose bolts, nuts and set screws.
3. Touch up unpainted and exposed areas with paint to prevent rust.
4. Coat the digging chain with a thin covering of oil. Operate chain for a short period to work the oil into the pins.
5. Store the trencher in a dry and protected area. Leaving the trencher outside, exposed to the elements will materially shorten its life.
6. Inspect trencher for visible signs of wear, breakage or damage. Order any parts required and make necessary repairs to avoid delays when starting next season.
7. Replace any decals if damaged or in unreadable condition.

REMOVING FROM STORAGE

1. Remove all protective coverings.
2. Check hydraulic hoses for deterioration and if necessary, replace.
3. During cold weather, operate the trencher slowly for a short time before placing the unit under full load.

— TROUBLE SHOOTING —

615 TRENCHER

GENERAL INFORMATION

Your trencher was designed to be as simple and as trouble free as possible. The purpose of this section is to help you in the event that a problem does develop. While we cannot possibly cover every problem that might occur, you will find that those that are most common are covered here.

PROBLEM: Digging chain will not turn

POSSIBLE CAUSE AND REMEDY:

1. Quick coupler not completely engaged. Check to see that all couplers are matched pairs and engaged correctly. Check coupler hook-up information (See Section E) for proper hydraulic hose routing.
2. Quick coupler failure. Check couplers for dirt, rust, or other contaminants that could affect coupler engagement. Clean or replace couplers as needed.
3. Obstruction in hydraulic hose. Remove hydraulic hoses and couplers one at a time, and check flow through hose by blowing through the hose or by pouring hydraulic fluid through the hose. Clean or replace hose, as needed.
4. Loader auxiliary hydraulics not operating properly. See loader operator's manual or dealer for information and help.
5. Hydraulic motor failed. Be sure you have hydraulic flow to the motor. If oil flow to motor is good, but motor will still not turn when detached from trencher headshaft, remove motor and have it serviced or replaced, as needed.
6. Headshaft bearings failed. Inspect headshaft bearings for free movement. Check for binding or foreign matter jamming bearing. Clean or replace, as necessary.
7. Boom end bearing failed. Inspect boom end bearing for free movement. Check for binding or foreign matter jamming bearing. Clean or replace, as necessary.
8. Digging chain too tight. Digging chain should only be tight enough to remain on sprockets while turning under load. There should be some sag in the chain. If too tight, loosen chain by the adjusting nut(s) on the boom.

TROUBLE SHOOTING

615 TRENCHER

9. Sand build-up in tooth root of sprocket. Sand can build up in the sprockets, effectively increasing the chain tension. Raise the boom out of the ditch and reverse the digging chain on the trencher, then run the trencher out of the trench to clear the sprockets. Reinstall the chain in its correct digging direction, and readjust chain tension.
10. Drive sprocket loose on headshaft. Observe if the headshaft is turning. If shaft is turning but sprocket is not, stop the trencher and tighten the sprocket.

PROBLEM: Trencher does not dig fast enough

POSSIBLE CAUSE AND REMEDY:

1. Digging teeth worn. See maintenance Section L in this manual. Inspect teeth and replace, as needed.
2. Loader relief valve set too low. See loader operator's manual and or dealer for proper relief valve service and adjustment.
3. Quick coupler or hose restriction. Inspect couplers and hoses for dirt, rust, and other contaminants and repair or replace, as needed.
4. Hydraulic system over heating. Shut the trencher and loader down, and allow oil to cool. Repeated stalling of the trencher will cause the oil to overheat. Avoid excessive stalling.
5. Cutting a ditch size beyond the ability of the loader. Your trencher is powered by oil from the loader's auxiliary hydraulic system. The horsepower transmitted through the auxiliary hydraulics is substantially less than that of the engine.

PROBLEM: Hydraulic oil over heating

POSSIBLE CAUSE AND REMEDY:

1. Loader relief valve set too low. See loader operator's manual, and/or dealer for proper relief valve service and adjustment.
2. Quick coupler or hose restriction. Inspect couplers and hoses for dirt, rust, and other contaminants and repair or replace, as needed.

TROUBLE SHOOTING

615 TRENCHER

3. Motor or hose size not balanced to loader. A hose or a motor that is too small can cause added internal friction and resultant heat build-up. Check mounting kit parts list and diagram (See Section E) for proper hose size and type.

4. Loader not equipped with oil cooler or sufficient sump capacity. Check with your loader dealer for information and availability of auxiliary cooling and sump kits. Install, if available. If not available, stop loader and trencher and allow them to cool when they get too hot.



BOLT TORQUE

BOLT TORQUE SPECIFICATIONS

GENERAL TORQUE SPECIFICATION TABLE

Use the following torques when special torques are not given. These values apply to fasteners as received from suppliers, dry, or when lubricated with normal engine oil. They do not apply if special graphited or moly disulphide greases or other extreme pressure lubricants are used. This applies to both UNF and UNC threads. Remember to always use grade five or better when replacing bolts.

SAE Grade No.		2				5				8*			
Bolt head identification marks as per grade. NOTE: Manufacturing Marks Will Vary													
		TORQUE		TORQUE		TORQUE		TORQUE		TORQUE		TORQUE	
Bolt Size		Pounds Feet		Newton-Meters		Pounds Feet		Newton-Meters		Pounds Feet		Newton-Meters	
Inches	Millimeters	Min.	Max.	Min.	Max.	Min.	Max.	Min.	Max.	Min.	Max.	Min.	Max.
1/4	6.35	5	6	6.8	8.13	9	11	12.2	14.9	12	15	16.3	30.3
5/16	7.94	10	12	13.6	16.3	17	20.5	23.1	27.8	24	29	32.5	39.3
3/8	9.53	20	23	27.1	31.2	35	42	47.5	57.0	45	54	61.0	73.2
7/16	11.11	30	25	40.7	47.4	54	64	73.2	86.8	70	84	94.9	113.9
1/2	12.70	45	52	61.0	70.5	80	96	108.5	130.2	110	132	149.2	179.0
9/16	14.29	65	75	88.1	101.6	110	132	149.2	179.0	160	192	217.0	260.4
5/8	15.88	95	105	128.7	142.3	150	180	203.4	244.1	220	264	298.3	358.0
3/4	19.05	150	185	203.3	250.7	270	324	366.1	439.3	380	456	515.3	618.3
7/8	22.23	160	200	216.8	271.0	400	480	542.4	650.9	600	720	813.6	976.3
1	25.40	250	300	338.8	406.5	580	696	786.5	943.8	900	1080	1220.4	1464.5
1-1/8	25.58	-	-	-	-	800	880	1084.8	1193.3	1280	1440	1735.7	1952.6
1-1/4	31.75	-	-	-	-	1120	1240	1518.7	1681.4	1820	2000	2467.9	2712.0
1-3/8	34.93	-	-	-	-	1460	1680	1979.8	2278.1	2380	2720	3227.3	3688.3
1-1/2	38.10	-	-	-	-	1940	2200	2630.6	2983.2	3160	3560	4285.0	4827.4

* Thick Nuts must be used with Grade 8 bolts

METRIC BOLT TORQUE SPECIFICATIONS

Size of Screw	Grade No.	Coarse Thread			Fine Thread		
		Ptich (mm)	Pounds Feet	Newton-Meters	Pitch (mm)	Pounds Feet	Newton-Meters
M6	5.6	1.0	3.6-5.8	4.9-7.9	-	-	-
	8.8		5.8-9.4	7.9-12.7		-	-
	10.9		7.2-10	9.8-13.6		-	-
M8	5.6	1.25	7.2-14	9.8-19	1.0	12-17	16.3-23
	8.8		17-22	23-29.8		19-27	25.7-36.6
	10.9		20-26	27.1-35.2		22-31	29.8-42
M10	5.6	1.5	20-25	27.1-33.9	1.25	20-29	27.1-39.3
	8.8		34-40	46.1-54.2		35-47	47.4-63.7
	10.9		38-46	51.5-62.3		40-52	54.2-70.5
M12	5.6	1.75	28-34	37.9-46.1	1.25	31-41	42-55.6
	8.8		51-59	69.1-79.9		56-68	75.9-92.1
	10.9		57-66	77.2-89.4		62-75	84-101.6
M14	5.6	2.0	49-56	66.4-75.9	1.5	52-64	70.5-86.7
	8.8		81-93	109.8-126		90-106	122-143.6
	10.9		96-109	130.1-147.7		107-124	145-168
M16	5.6	2.0	67-77	90.8-104.3	1.5	69-83	93.5-112.5
	8.8		116-130	157.2-176.2		120-138	162.6-187
	10.9		129-145	174.8-196.5		140-158	189.7-214.1
M18	5.6	2.0	88-100	119.2-136	1.5	100-117	136-158.5
	8.8		150-168	203.3-227.6		177-199	239.8-269.6
	10.9		175-194	237.1-262.9		202-231	273.7-313
M20	5.6	2.5	108-130	146.3-176.2	1.5	132-150	178.9-203.3
	8.8		186-205	252-277.8		206-242	279.1-327.9
	10.9		213-249	288.6-337.4		246-289	333.3-391.6

SPECIFICATIONS

615 TRENCHER

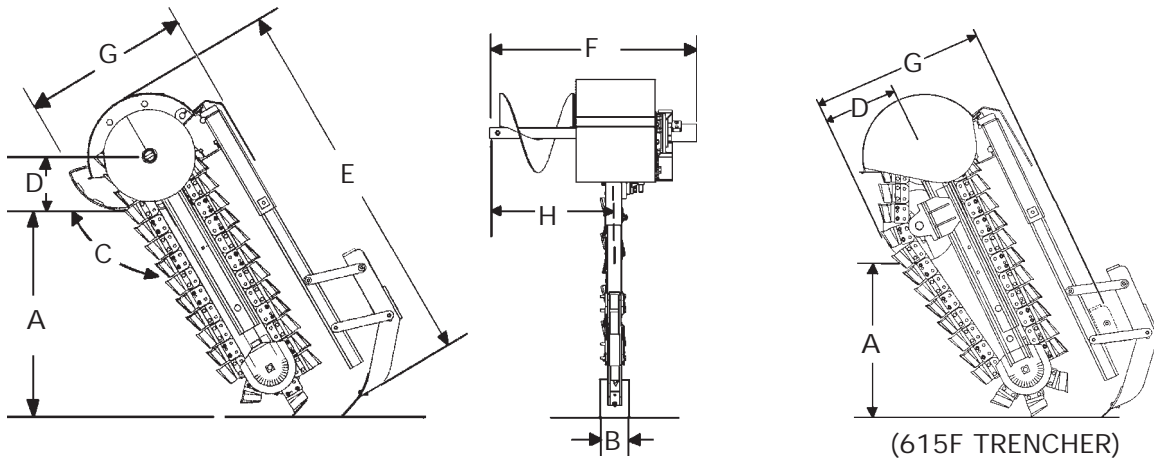

SPECIFICATIONS AND DESIGN ARE SUBJECT TO CHANGE WITHOUT NOTICE AND WITHOUT LIABILITY THEREFOR.

DESCRIPTION	BOOM SIZE			
	24"	30"	36"	48"
A. 615 Trench Depth w/Auger @ 65° Digging Angle	24"	30"	36"	48"
615F Trench Depth w/Auger @ 65° Digging Angle	24"	30"		
B. 615 Chain Widths Available	6" 8" 10" 12"	6" 8" 10"	4.5" 6" 8"	4.5" 6"
615F Chain Widths Available	6" 8" 10" 12"	6" 8" 10"		
C. Recommended Trenching Angle	65°	65°	65°	65°
D. 615 Headshaft Height	10"	10"	10"	10"
615F Headshaft Height	17"	17"		
E. 615 Overall Trencher Length	51"	58"	65"	78"
615F Overall Trencher Length	65"	72"		
F. 615 Overall Trencher Width	42"	42"	42"	42"
615F Overall Trencher Width	26"	26"		
G. Overall Trencher Height	28"	28"	28"	28"
615F Overall Trencher Height	29"	29"		
H. 615 Spoil Discharge Reach	24"	24"	24"	24"
615F Spoil Discharge Reach	18"	18"		
Hydrostatic System:				
GPM Requirements			6-10 or 10-16	
Operating Pressure			2000 - 3000 PSI	
Approximate Overall Shipping Weight (with 3' boom and 6" cup tooth chain and no mount)				510 lbs

DECALS

DECAL PLACEMENT

GENERAL INFORMATION

The diagram on this page shows the location of the decals used on the BRADCO 615 & 615F trenchers. The decals are identified by their part numbers, with reductions of the actual decals located on the following page. Use this information to order replacements for lost or damaged decals. Be sure to read all decals before operating the attachment. They contain information you need to know for both safety and product longevity.

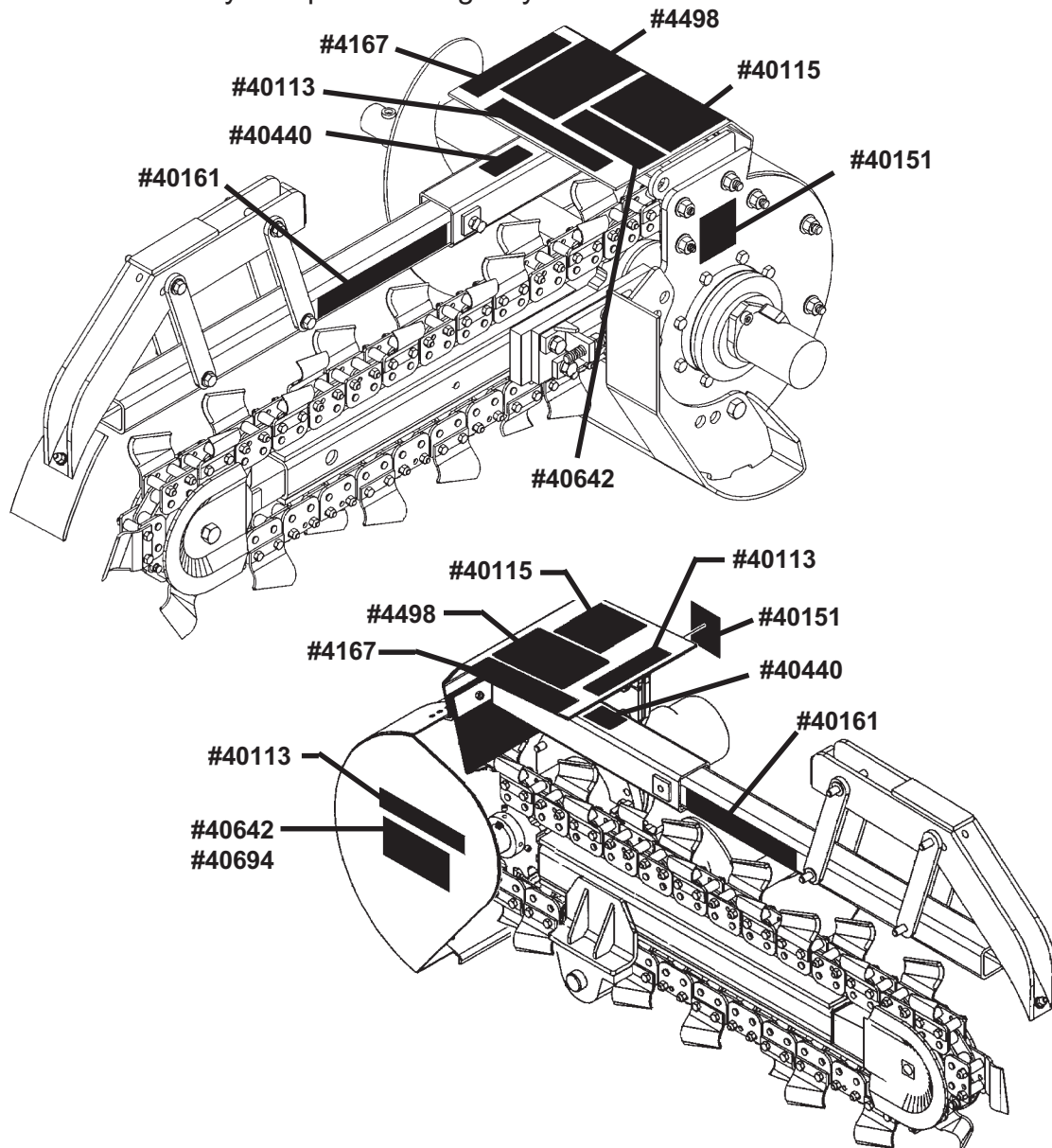

IMPORTANT: Keep all safety signs clean and legible. Replace all missing, illegible, or damaged safety signs. When replacing parts with safety signs attached, the safety signs must also be replaced.

REPLACING SAFETY SIGNS: Clean the area of application with nonflammable solvent, then wash the same area with soap and water. Allow the surface to fully dry. Remove the backing from the safety sign, exposing the adhesive surface. Apply the safety sign to the position shown in the diagram above, and smooth out any bubbles.

DECALS

⚠ WARNING

READ THE TRENCHER OPERATOR'S MANUAL BEFORE YOU USE THE TRENCHER.

USE THE TRENCHER ONLY WITH A LOADER IDENTIFIED IN TRENCHER OPERATOR'S MANUAL. READ THE LOADER OPERATOR'S MANUAL.

BYSTANDERS MUST BE AT LEAST 6 FEET (2 METERS) OR MORE AWAY FROM THE TRENCHER DURING OPERATION.

OPERATION OF THE TRENCHER MUST BE DONE ONLY FROM THE OPERATOR SEAT OF THE SKID-STEER.

ALWAYS LOWER THE TRENCHER TO THE GROUND AND SHUT ENGINE OFF BEFORE LEAVING THE OPERATOR'S SEAT.

SIDE SHIFT OR TILT OPERATIONS MUST BE PERFORMED WITH THE TRENCHER LOW TO THE GROUND.

DO NOT OPERATE TRENCHER WITH CHAIN GUARDS REMOVED.

ALWAYS CHECK FOR BURIED FACILITIES BEFORE TRENCHING.

NEVER TRY TO REMOVE ROCKS FROM DIGGING CHAIN WITH CHAIN RUNNING.

FAILURE TO OBEY WARNINGS MAY CAUSE INJURY OR DEATH.

PART #40115
WARNING

BRADCO

PART #40113
BRADCO LOGO

⚠ WARNING



HIGH-PRESSURE FLUID HAZARD

To prevent serious injury or death:

- Relieve pressure on system before repairing or adjusting or disconnecting.
- Wear proper hand and eye protection when searching for leaks. Use wood or cardboard instead of hands.
- Keep all components in good repair.

#40151

PART #40151
WARNING



1-888-258-0808

40440

PART #40440
CALL BEFORE YOU DIG

STAND CLEAR

PART #40161
STAND CLEAR

NO STEP

PART #4167
NO STEP

⚠ DANGER



Stand clear of digging chain and trench. Contact with chain and teeth or cave in of trench wall can cause serious injury or death.

#4498

PART #4498
DANGER

615 F

PART #40642
615 MODEL NUMBER

PART #40694
"F" FOOTING TRENCHER DECAL

PREDELIVERY CHECKLIST

615 TRENCHER

GENERAL INFORMATION

The following is a list of areas that should be inspected by the dealer prior to delivery of the trencher to the customer. The customer should check the list and make sure that the dealer has completed the inspection. Completion of this checklist will help insure that the customer receives the trencher in complete working order, ready to install.

PREDELIVERY CHECKLIST - CHECK AND ADJUST AS NECESSARY

1. _____ Visually inspect the trencher for bent, loose, cracked, damaged or missing parts. Check for any other irregularities.
2. _____ Check all hydraulic connections for leaks and all hoses for proper positioning to reduce chafing and binding.
3. _____ Check the trencher's digging chain adjustment. See "Operating Instructions - Chain Tension Adjustment" Section G.
4. _____ Check trencher attachment bolts for tightness. Retighten after the first eight working hours, and after every forty working hour interval thereafter. See "Bolt Torque" Section O.
5. _____ Make sure decals are not damaged or missing and are in their correct location. See "Decals" Section Q.
6. _____ Complete and return the manufacturers "Warranty Validation Form" and sign your dealership predelivery checklist.
7. _____ Operator to read the Trencher Safety Manual provided, before operating trencher.

LIMITED WARRANTY

EFFECTIVE ON PRODUCTS MANUFACTURED AFTER JANUARY 1, 2001

All new BRADCO products are warranted to be free from defects in materials or workmanship which may cause failure under normal usage and service when used for the purpose intended.

In the event of failure within twenty four (24) months from initial retail sale, lease or rental date (excluding cable, ground engaging parts such as sprockets, digging chain, bearings, teeth, tamping and demolition heads, blade cutting edges, pilot bits, auger teeth, auger heads & broom bristles), if after examination, BRADCO determines failure was due to defective material and/or workmanship, parts will be repaired or replaced. BRADCO may request defective part or parts be returned prepaid to them for inspection at their place of business at Delhi, Iowa, or to a location specified by BRADCO.

Any claims under this warranty must be made within fifteen (15) days after the Buyer learns of the facts upon which such claim is based. All claims not made in writing and received by BRADCO within the time period specified above shall be deemed waived.

THIS WARRANTY IS IN LIEU OF ALL OTHER WARRANTIES EXPRESSED OR IMPLIED AND THERE ARE NO WARRANTIES OF MERCHANTABILITY OR OF FITNESS FOR A PARTICULAR PURPOSE. IN NO EVENT SHALL BRADCO BE LIABLE FOR CONSEQUENTIAL OR SPECIAL DAMAGE.

BRADCO'S LIABILITY FOR ANY AND ALL LOSSES AND DAMAGES TO BUYER, RESULTING FROM ANY CAUSE WHATSOEVER, INCLUDING BRADCO'S NEGLIGENCE, IRRESPECTIVE OF WHETHER SUCH DEFECTS ARE DISCOVERABLE OR LATENT, SHALL IN NO EVENT EXCEED THE PURCHASE PRICE OF THE PARTICULAR PRODUCTS WITH RESPECT TO WHICH LOSSES OR DAMAGES ARE CLAIMED, OR, AT THE ELECTION OF BRADCO, THE REPAIR OR REPLACEMENT OF DEFECTIVE OR DAMAGED PRODUCTS.