



BRADCO

BY PALADIN

PARTS MANUAL

611B BACKHOE

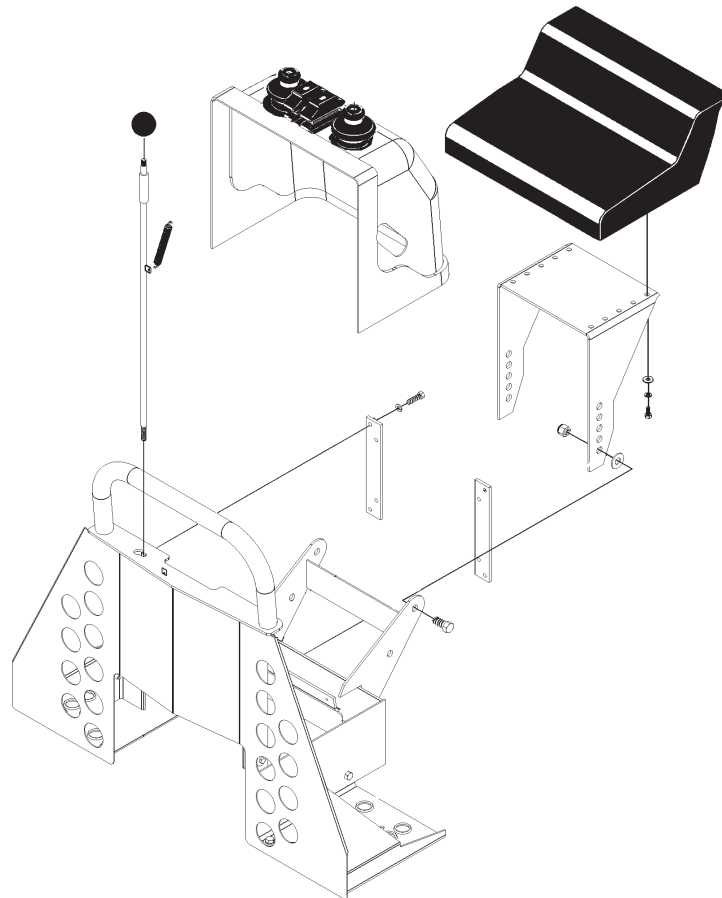

SERIAL NUMBER: _____

MODEL NUMBER: _____

Manual Number: PM855
Part Number: 75755
Rev. 2

Limited Warranty

Except for the Excluded Products as described below, all new products are warranted to be free from defects in material and/or workmanship during the Warranty Period, in accordance with and subject to the terms and conditions of this Limited Warranty.

1. Excluded Products. The following products are excluded from this Limited Warranty:

(a) Any cable, part that engages with the ground (i.e. sprockets), digging chain, bearing, teeth, tamping and/or demolition head, blade cutting edge, pilot bit, auger teeth and broom brush that either constitutes or is part of a product.

(b) Any product, merchandise or component that, in the opinion of Paladin Light Construction¹, has been (i) misused; (ii) modified in any unauthorized manner; (iii) altered; (iv) damaged; (v) involved in an accident; or (vi) repaired using parts not obtained through Paladin Light Construction.

2. Warranty Period. The Limited Warranty is provided only to those defects that occur during the Warranty Period, which is the period that begins on the first to occur of: (i) the date of initial purchase by an end-user, (ii) the date the product is first leased or rented, or (iii) the date that is six (6) months after the date of shipment by Paladin Light Construction as evidenced by the invoiced shipment date (the "Commencement Date") and ends on the date that is twenty-four (24) months after the Commencement Date.

3. Terms and Conditions of Limited Warranty. The following terms and conditions apply to the Limited Warranty hereby provided:

(a) Option to Repair or Replace. Paladin Light Construction shall have the option to repair or replace the product.

(b) Timely Repair and Notice. In order to obtain the Limited Warranty, (i) the product must be repaired within thirty (30) days from the date of failure, and (ii) a claim under the warranty must be submitted to Paladin Light Construction in writing within thirty (30) days from the date of repair.

(c) Return of Defective Part or Product. If requested by Paladin Light Construction, the alleged defective part or product shall be shipped to Paladin Light Construction at its manufacturing facility or other location specified by Paladin Light Construction, with freight PRE-PAID by the claimant, to allow Paladin Light Construction to inspect the part or product.

Claims that fail to comply with any of the above terms and conditions shall be denied.

LIMITATIONS AND EXCLUSIONS.

THIS LIMITED WARRANTY IS IN LIEU OF ALL OTHER WARRANTIES, EXPRESS OR IMPLIED, INCLUDING WITHOUT LIMITATION THE WARRANTIES OF MERCHANTABILITY, FITNESS FOR A PARTICULAR PURPOSE AND ANY WARRANTY BASED ON A COURSE OF DEALING OR USAGE OF TRADE.

IN NO EVENT SHALL PALADIN LIGHT CONSTRUCTION BE LIABLE FOR CONSEQUENTIAL OR SPECIAL DAMAGES.

IN NO EVENT SHALL PALADIN LIGHT CONSTRUCTION BE LIABLE FOR ANY LOSS OR CLAIM IN AN AMOUNT IN EXCESS OF THE PURCHASE PRICE, OR, AT THE OPTION OF PALADIN LIGHT CONSTRUCTION, THE REPAIR OR REPLACEMENT, OF THE PARTICULAR PRODUCT ON WHICH ANY CLAIM OF LOSS OR DAMAGE IS BASED. THIS LIMITATION OF LIABILITY APPLIES IRRESPECTIVE OF WHETHER THE CLAIM IS BASED ON BREACH OF CONTRACT, BREACH OF WARRANTY, NEGLIGENCE OR OTHER CAUSE AND WHETHER THE ALLEGED DEFECT IS DISCOVERABLE OR LATENT.

¹Attachment Technologies Inc., a subsidiary of Paladin Brands Holding, Inc. (PBHI) is referred to herein as Paladin Light Construction.

February 10, 2010

**THIS PAGE
IS INTENTIONALLY
BLANK**

TABLE OF CONTENTS

SERVICE PARTS

MAINFRAME ASSEMBLY #87443	
Mainframe.....	4-5
Swing Post.....	6-7
Swing Cylinder.....	8-9
Stabilizers	10-11
Hose Bundle Clamps.....	12-13
BOOM & DIPPER ASSEMBLY #118249	14-17
CONSOLE ASSEMBLY #118259	18-19
VALVE ASSEMBLY #2275	
Valve Assembly #2275 - Units Built After April 1, 2014	20-21
Valve Assembly #2275 - Units Built Before April 1, 2014.....	22-23
Service Parts	24-25
CYLINDERS	
SWING CYLINDER #81827	26-27
STABILIZER CYLINDER #82980	28-29
BOOM CYLINDER #82476.....	30-31
DIPPER CYLINDER #85779	32-33
BUCKET CYLINDER #117548	34-35
HOSE SETS	
MAINFRAME HOSE SET #82761	36-37
BOOM & DIPPER HOSE SET #82763.....	38-39
STABILIZER PAD OPTIONS	
FLAT STABILIZER PAD ASSEMBLY #83055.....	40-41
GROUSER STABILIZER PAD ASSEMBLY #83054	40-41
RUBBER STABILIZER PAD ASSEMBLY #83056	40-41
FLIP-OVER STABILIZER PAD ASSEMBLY #83058	42-43
OPTIONAL STABILIZER CYLINDER COVER #86706	44-45
BUCKET ASSEMBLIES	46-47
611B FIRST LINE REPAIR KIT #83759	48-49
DECALS	50-53

MAINFRAME ASSEMBLY

ASSEMBLY #87443

MAINFRAME

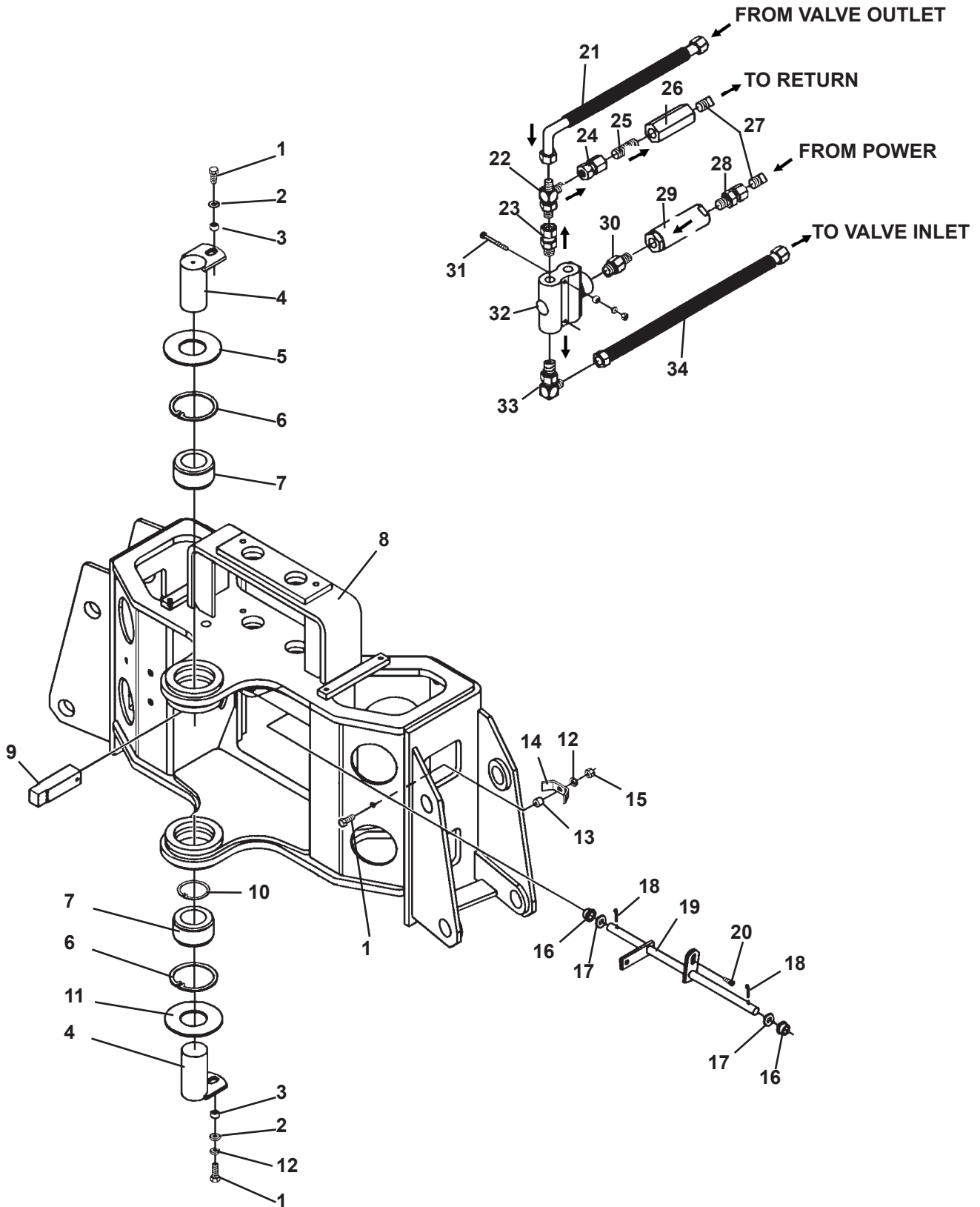

MAINFRAME ASSEMBLY

ASSEMBLY #87443

MAINFRAME

<u>ITEM</u>	<u>REQ'D</u>	<u>PART NO.</u>	<u>DESCRIPTION</u>
1	4	1043	.38" UNC X 1.00" Hex Capscrew (Pin retaining capscrews installed with Locktite Grade 242)
2	2	1514	.38" Flat Washer
3	2	81807	Spacer Tube
4	2	82423	Pin
	2	6616	Grease Zerk
5	1	82613	Thrust Washer 2.00 X .125"
6	2	1734	Snap Ring
7	2	82435	Bearing
8	1	82446	Mainframe (Includes (4) #83815 Bushings, (4) 82447 Bushings (Installed with Locktite Grade 680)
9	1	82090	Swing Lock Pin
10	1	1666	Snap Ring
11	As Req'd	82611	Thrust Washer 2.00" X .030"
	As Req'd	82612	Thrust Washer 2.00" X .060"
	As Req'd	82613	Thrust Washer 2.00" X .125"
12	3	1503	.38" Lock Washer
13	2	6799	Spacer
14	2	6186	Hose Clamp
15	2	1226	.38" UNC Hex Nut
16	2	82794	Bushing
17	As Req'd	1528	.62" SAE Flat Washer
18	2	1611	Cotter Pin .12 X 1.00"
19	1	82796	Linkage
20	1	1982	Shoulder Screw
21	1	37554	Hose .50" X 36" 8FJX 90° - 8FJX 90°
22	1	30409	Tee
23	2	30377	Bushing 12MBo - 8FBo
24	1	3273	Coupling 8FP-8FJX
25	1	3309	Heavy Close Nipple .50 NPT x 4.00" (Check Valve)
26	1	45691	Check Valve (Hex)
27	2	3189	Square Head Plug
28	1	30469	Straight Connector 8MBo-8FP
29	1	107635	Inline Filter (Round)
30	1	30245	Straight Connector 8MBo-12MBo
31	2	1010	.25" UNC X 2.75" Hex Capscrew
	2	81595	Spacer
	8	1512	.25" Flat Washer
	2	1501	.25" Lock Washer
	2	1224	.25" UNC Hex Nut
32	1	82609	Priority Flow Divider
33	1	3316	90° Adapter 12MBo-8MJ
34	1	37690	Hose .50" X 41" 8FJX-8FJX 45°

NOTE: Use thrust washers (Item #11) to adjust mainframe / swing post to minimum free play.

12597 11-26-13

MAINFRAME ASSEMBLY

ASSEMBLY #87443

SWING POST

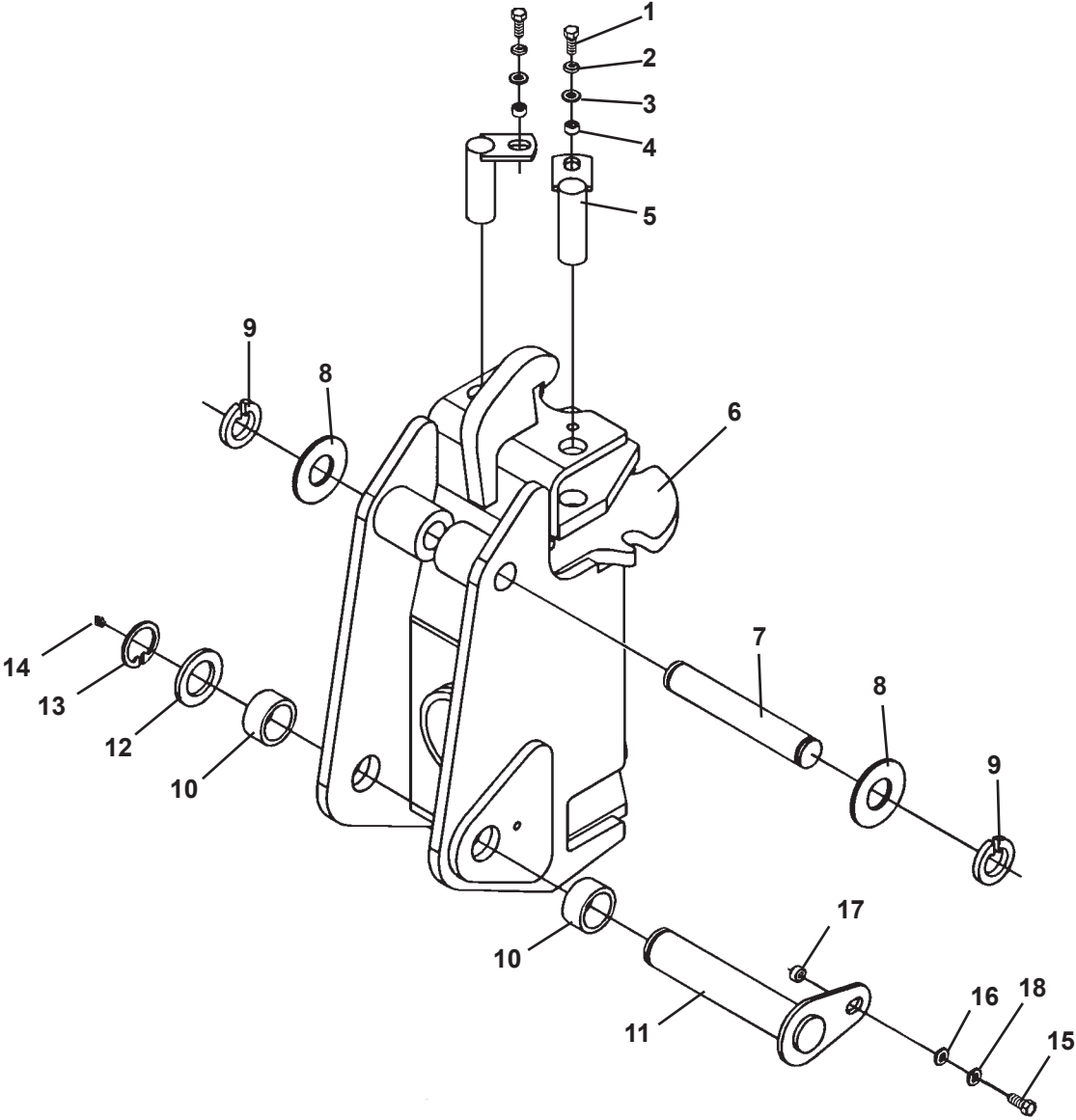

MAINFRAME ASSEMBLY

ASSEMBLY #87443

SWING POST

<u>ITEM</u>	<u>REQ'D</u>	<u>PART NO.</u>	<u>DESCRIPTION</u>
1	2	1043	.38" UNC X 1.00" Hex Capscrew (Installed with Locktite Grade 242)
2	2	1503	.38" Lock Washer
3	2	1514	.38" Flat Washer
4	2	81807	Spacer Tube
5	2	81847	Pin
6	1	82408	Swing Post (Includes (2) 82402 Bushings Installed with Locktite Grade 680)
7	1	82415 (1)	Pivot Pin
8	As Req'd	6623	Thrust Washer 1.38" X .031"
	As Req'd	64724	Thrust Washer 1.38" X .090"
	As Req'd	64725	Thrust Washer 1.38" X .125"
9	2	1650	Snap Ring
10	-	82402	Bushing (Included with Swing Post) (Installed with Locktite Grade 680)
11	1	82416	Pivot Pin
12	As Req'd	6622	Thrust Washer 1.75" X .082"
13	1	1651	Snap Ring
14	1	6616	Grease Zerk
15	1	1088	.50" UNC X 1.00" Hex Capscrew
16	1	1516	.50" Flat Washer
17	1	86149	Spacer Tube
18	1	1505	.50" Lock Washer

NOTE:

(1) Pivot Pin #82415 is sold only in Pin Kit #86306. Kit includes one pin #82415, two thrust washers #6623 and two snap rings #1650.

12599 11-26-13

MAINFRAME ASSEMBLY

ASSEMBLY #87443

SWING CYLINDERS

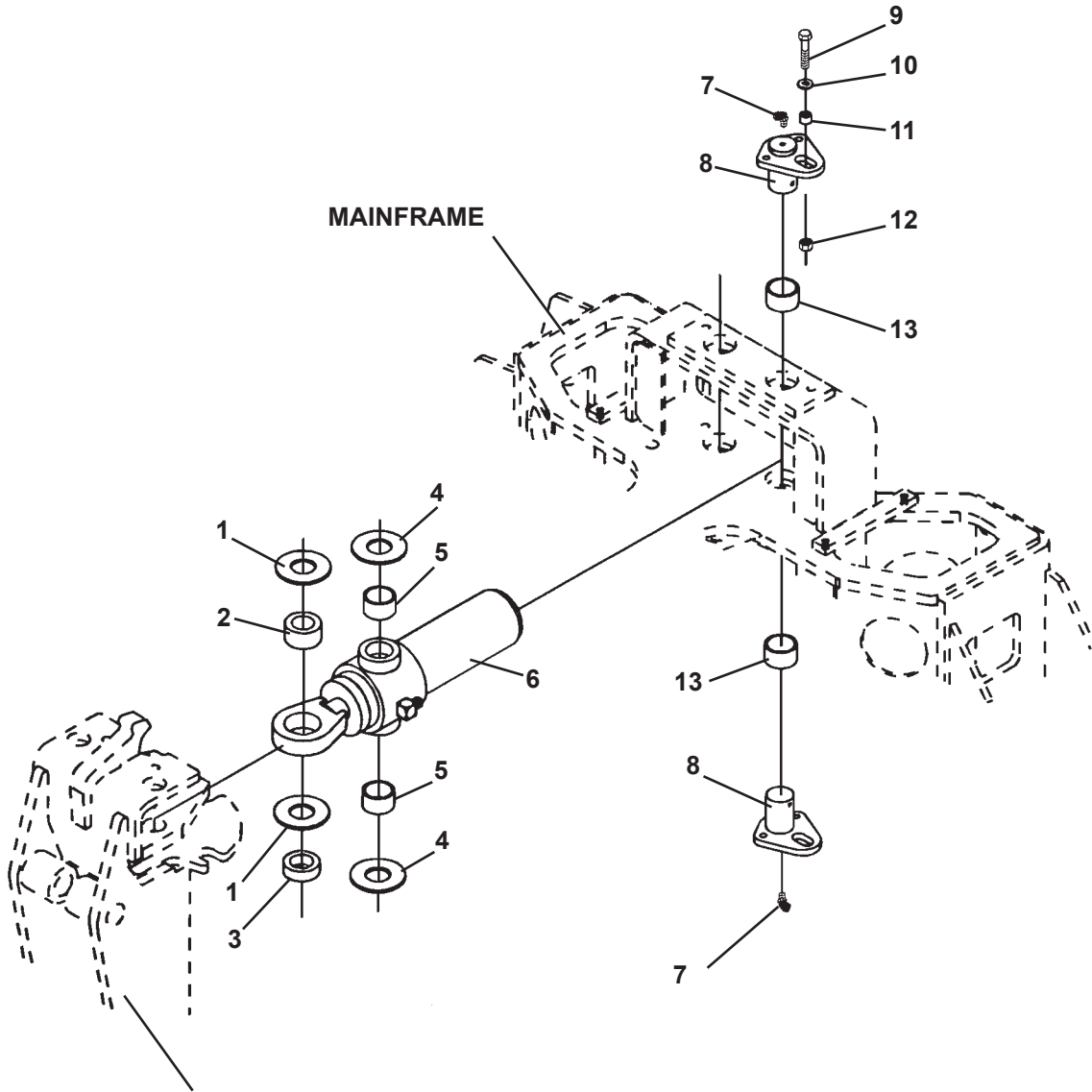

MAINFRAME ASSEMBLY

ASSEMBLY #87443

SWING CYLINDERS

<u>ITEM</u>	<u>REQ'D</u>	<u>PART NO.</u>	<u>DESCRIPTION</u>
1	As Req'd	57693	Thrust Washer 1.25" X .078"
	As Req'd	64727	Thrust Washer 1.25" X .145"
2	-	62523	Self Aligning Bushing (Included in Swing Cylinder Assembly)
3	2	82827	Spacer
4	As Req'd	68057	Thrust Washer 1.50"
5	-	82441	Needle Bearing (Included in Swing Cylinder Assembly)
6	2	81022	Swing Cylinder Assembly (Includes (2) #82441 Needle Bearings and (1) #62523 Bushing)
	2	6616	Grease Zerk
	2	30164	Special LH Lateral Tee
7	4	53031	90° Grease Zerk
8	4	82420	Pin
9	4	1047	.38" UNC X 2.00" Hex Capscrew
10	4	1514	.38" Flat Washer
11	4	81595	Spacer Tube
12	4	1837	.38" UNC Hex Lock Nut
13	-	83815	Bushing (Included in Mainframe - Installed with Loctite Grade 680)

MAINFRAME ASSEMBLY

ASSEMBLY #87443

STABILIZERS

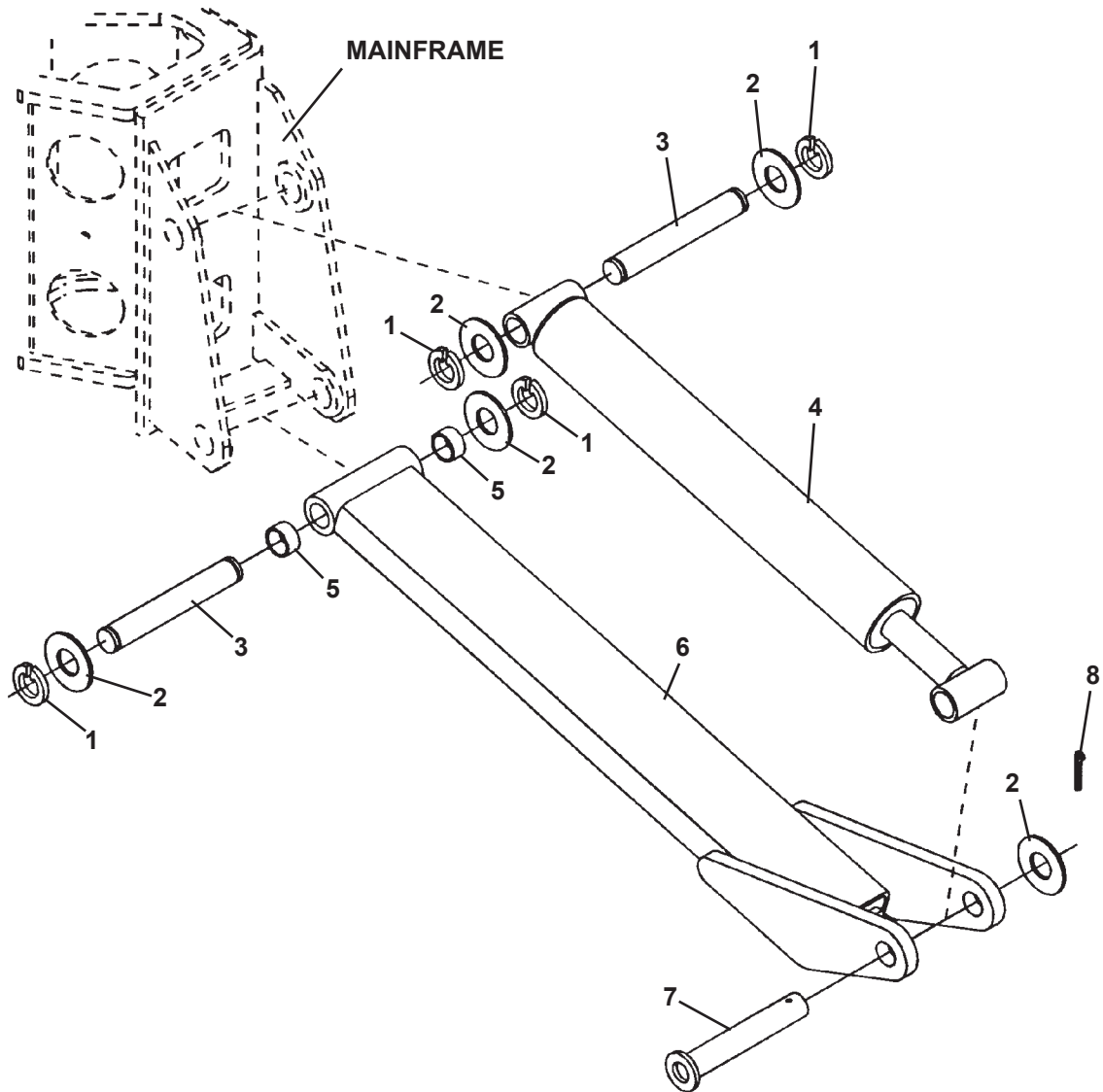

MAINFRAME ASSEMBLY

ASSEMBLY #87443

STABILIZERS

<u>ITEM</u>	<u>REQ'D</u>	<u>PART NO.</u>	<u>DESCRIPTION</u>
1	8	1652	Snap Ring
2	As Req'd	57693	Thrust Washer 1.25" X .078"
	As Req'd	64727	Thrust Washer 1.25" X .145"
	As Req'd	64728	Thrust Washer 1.25" X .031"
3	4	82993 (1)	Pin
4	2	82980	Stabilizer Cylinder Assembly
	4	6616	Grease Zerk
5	-	82447	Bushing (Included in Mainframe - Installed with Loctite Grade 680)
6	2	82958	Stabilizer Arm
7	2	83233	Pin
8	2	1613	Cotter Pin .25" X 2.00"

NOTE:

(1) Pivot Pin #82993 is sold only in Pin Kit #86310. Kit includes one pin #82993, two thrust washers #64727 and two snap rings #1652.

12603 11-26-13

HOSE BUNDLE CLAMPS

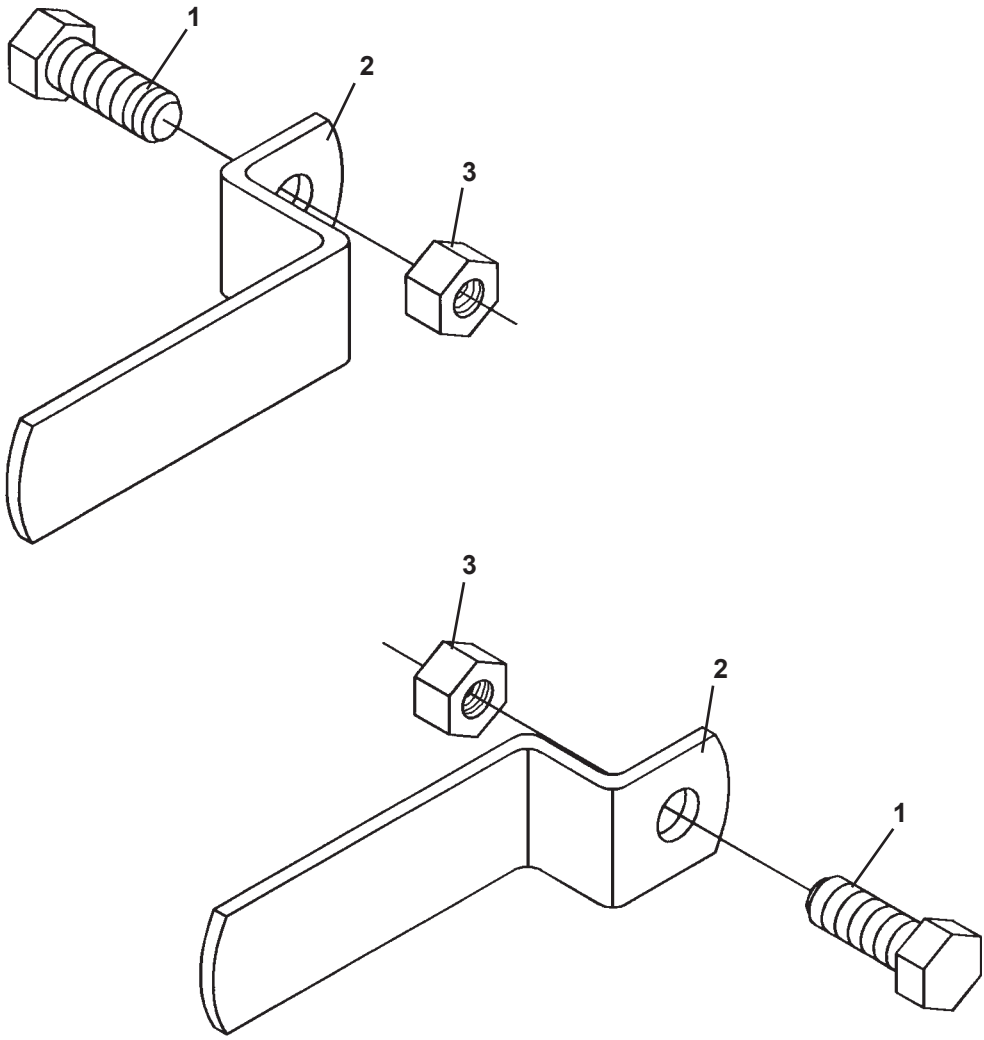

HOSE BUNDLE CLAMPS

<u>NO</u>	<u>REQ'D</u>	<u>PART NO.</u>	<u>DESCRIPTION</u>
1	2	1043	.38" UNC X 1.00" Hex Capscrew
2	1	84718	Right Hose Bundle Clamp
3	2	1837	.38" UNC Deformed Lock Nut
4	1	84718	Left Hose Bundle Clamp

611B BOOM & DIPPER ASSEMBLY

ASSEMBLY #118249

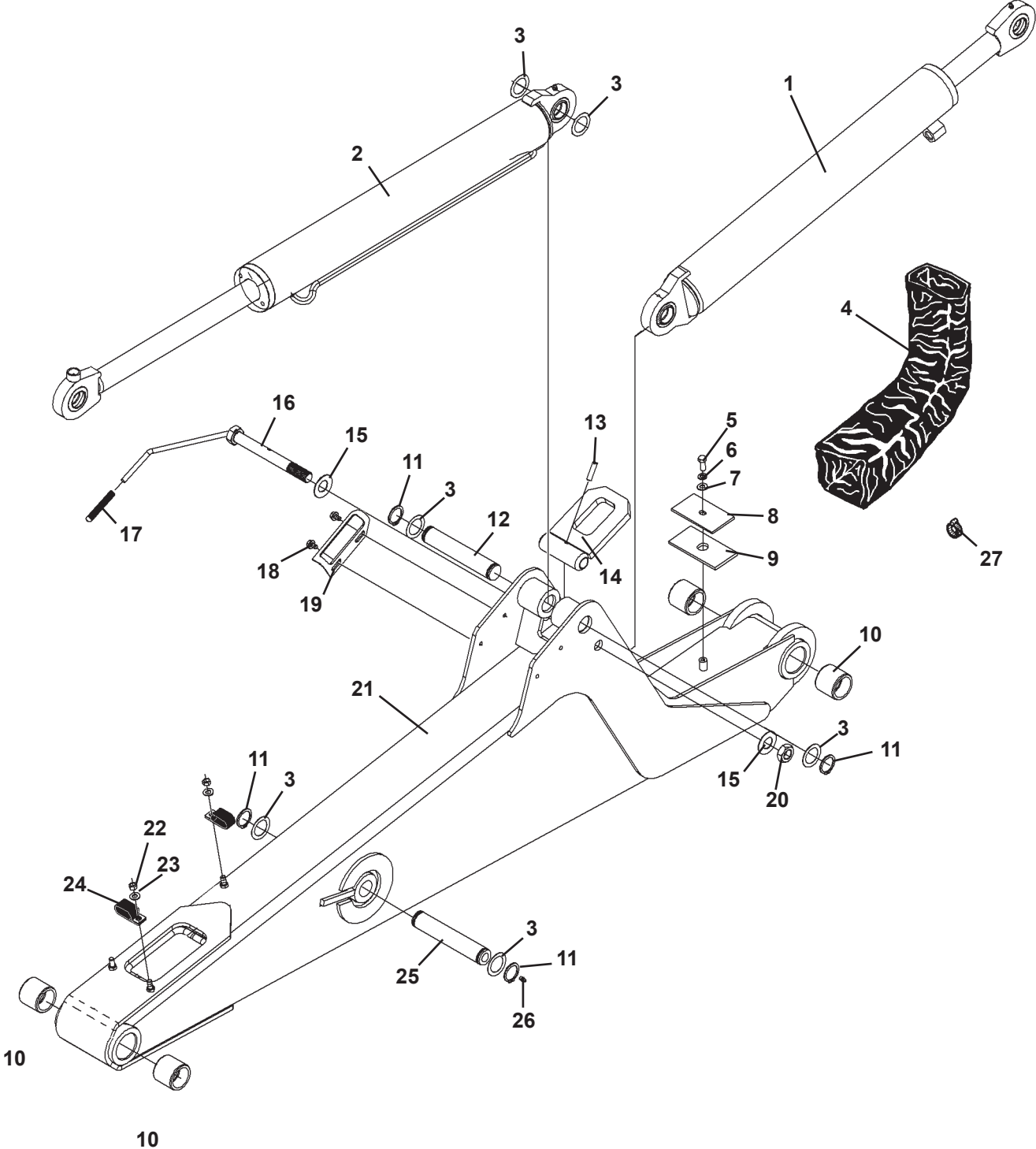

611B BOOM & DIPPER ASSEMBLY

ASSEMBLY #118249

<u>NO</u>	<u>REQ'D</u>	<u>PART NO.</u>	<u>DESCRIPTION</u>
1	1	82476	Boom Cylinder Assembly
	-	6615	Self Aligning Bushing (Included in Cylinder Assembly)
	1	6616	Grease Zerk
	2	3103	Straight Adapter
2	1	85779	Dipper Cylinder Assembly
	-	6615	Self Aligning Bushing (Included in Cylinder Assembly)
	2	6616	Grease Zerk
	2	3103	Straight Adapter
3	As Req'd	6623	Thrust Washer 1.38" X .031"
	As Req'd	64724	Thrust Washer 1.38" X .090"
	As Req'd	64725	Thrust Washer 1.38" X .125"
4	1	34120	Hose Sock
5	1	1043	.38" UNC X 1.00" Hex Capscrew
6	1	1503	.38" Lock Washer
7	1	1514	.38" Flat Washer
8	1	82862	Clamp Plate
9	1	82863	Rubber Spacer
10	-	86673	Bushing (Included in Boom Assembly)
11	4	1650	Snap Ring
12	1	82534 ⁽¹⁾	Pivot Pin
13	1	1972	Roll Pin
14	1	86366	Boom Lock
15	2	6562	Spring Washer
16	1	86634	Boom Lock Handle
17	1	83656	Handle Grip
18	2	1961	.38" UNC X .50" Flange Head Hex Capscrew
19	1	84137	Guide Plate
20	1	1959	.88" UNC Jam Nut
21	1	82677	Boom Assembly (Includes (4) 86673 Bushings - Installed with Locktite Grade 680)
22	2	1837	.38" UNC Deformed Lock Nut
23	2	1525	.38" SAE Flat Washer
24	2	82859	Double Hose Clamp
25	1	82535 ⁽²⁾	Pivot Pin
26	1	6616	Grease Zerk
27	1	53167	Hose Clamp (Included in Console Assembly)

NOTES:

- (1) **Pivot Pin #82534 is sold only in Pin Kit #86309. Kit includes one pin #82534, two thrust washers #6623 and two snap rings #1650.**
- (2) **Pivot Pin #82535 is sold only in Pin Kit #86307. Kit includes one pin #82535, two thrust washers #6623, two snap rings #1650 and one grease zerk #6616.**

12606 4-18-14-2

611B BOOM & DIPPER ASSEMBLY

ASSEMBLY #118249

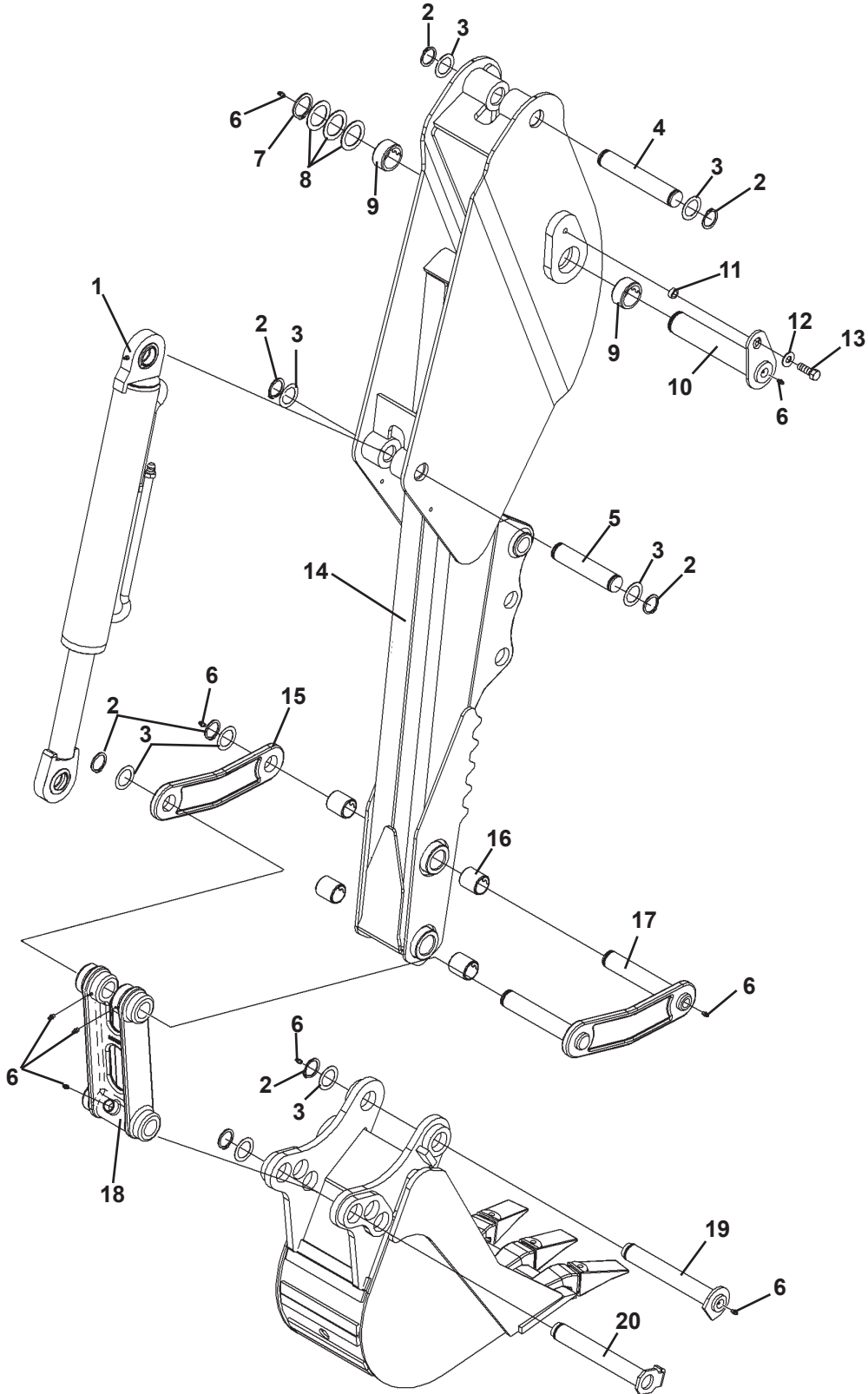

611B BOOM & DIPPER ASSEMBLY

ASSEMBLY #118249

<u>ITEM</u>	<u>REQ'D</u>	<u>PART NO.</u>	<u>DESCRIPTION</u>
1	1	117548	Bucket Cylinder Assembly
	-	6615	Self-Aligning Bushing (Included in Cylinder Assembly)
	2	6616	Grease Zerk
2	8	1650	Snap Ring
3	As Req'd	6623	Thrust Washer 1.38" X .031
	As Req'd	64724	Thrust Washer 1.38" X .090
	As Req'd	64725	Thrust Washer 1.38" X .125
4	1	82533 (1)	Pivot Pin
5	1	86225 (2)	Pivot Pin
6	6	6616	Grease Zerk
7	1	1651	Snap Ring
8	As Req'd	6622	Thrust Washer 1.75 X .082
9	-	82402	Bushing (Included in Dipper Assembly) (Install with Locktite Grade 680)
10	1	82416	Pivot Pin
11	1	86149	Spacer Tube
12	1	1516	.50" Flat Washer
13	1	1090	.50" UNC X 1.50" Hex Capscrew
14	1	118250	Dipper Assembly (Includes (2) 82402 and (2) 81610 Bushings) (Installed with Locktite Grade 680)
15	1	84914	Dipper Link Plate
16	-	81610	Bushing (Included in Dipper Assembly) (Install with Locktite Grade 680)
17	1	109353	Dipper Link
18	1	109326	Bucket Link
19	1	109410	Pivot Pin
20	1	109413	Pivot Pin

NOTE:

- (1) Pivot Pin #82533 is sold only in Pin Kit #86308. Kit Includes one pin #82533, two thrust washers #6623 and two snap rings #1650.
- (2) Pivot Pin #86225 is sold only in Pin Kit #86316. Kit Includes one pin #86226, two thrust washers #6623 and two snap rings #1650.

12608 11-27-13

CONSOLE ASSEMBLY

ASSEMBLY #118259

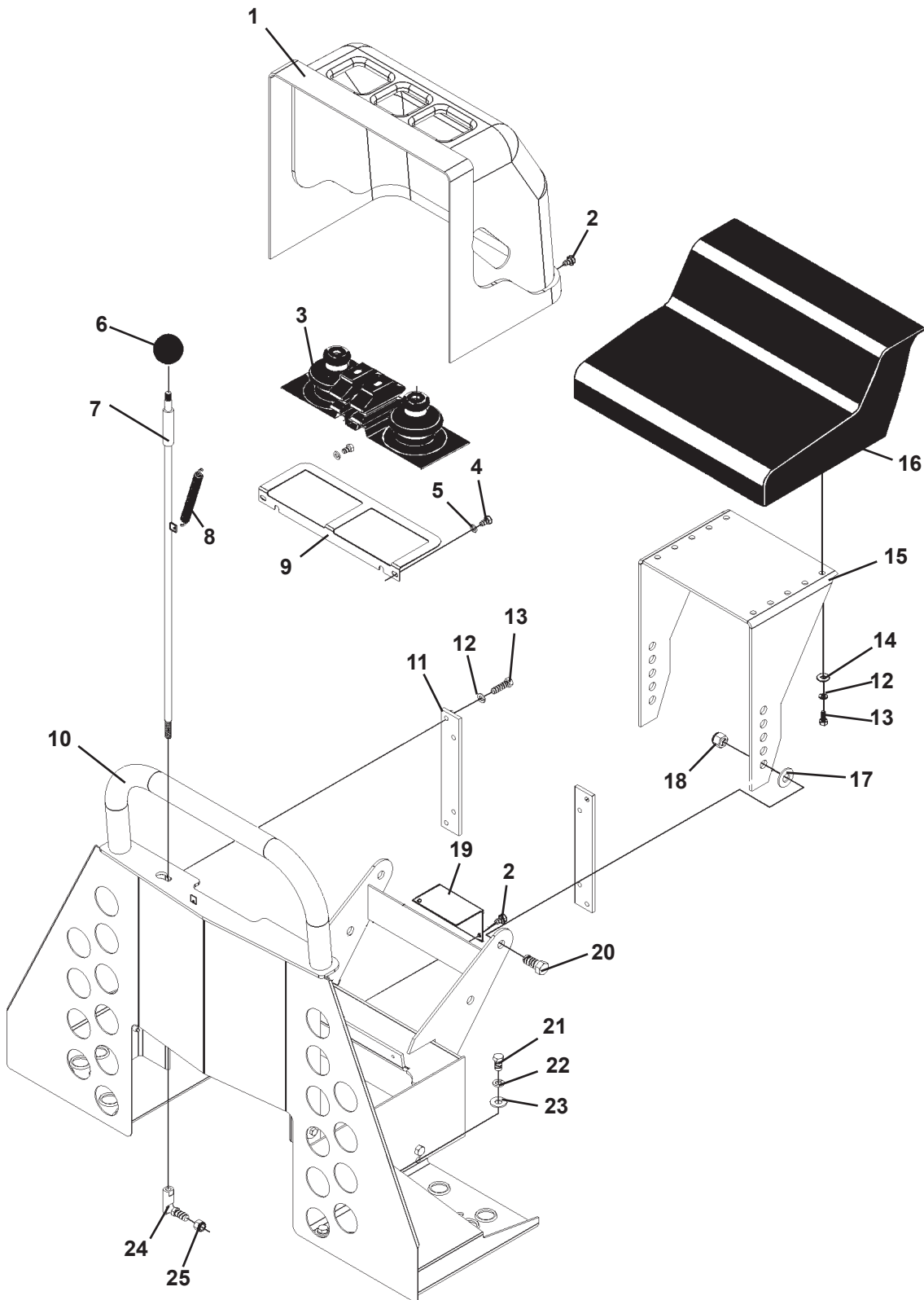

CONSOLE ASSEMBLY

ASSEMBLY #118259

<u>ITEM</u>	<u>REQ'D</u>	<u>PART NO.</u>	<u>DESCRIPTION</u>
1	1	106360	Console Cover with Decals
2	8	1958	.25" UNC X .75" Hex Capscrew
3	1	83235	Control Lever Boot
4	2	1001	.25" UNC X .50" Hex Capscrew
5	2	1501	.25" Lock Washer
6	1	83406	Ball Handle
7	1	83273	Rod
8	1	82795	Spring
9	1	85826	Boot Support Plate
10	1	118264	Console
11	2	119058	Valve Mounting Plate
12	8	1502	.31" Lock Washer
13	8	1021	.31" UNC X .75" Hex Capscrew
14	4	1513	.31" Flat Washer
15	1	87142	Seat Mount
16	1	6980	Seat
17	2	1516	.50" Flat Washer
18	2	1542	.50" UNC Nylock Nut
19	1	87147	Cover Plate
20	2	1089	.50" UNC X 1.25" Hex Capscrew
21	4	1042	.38" UNC X .75" Hex Capscrew
22	4	1503	.38" Lock Washer
23	4	1514	.38" Flat Washer
24	1	5545	Ball Joint
25	1	1592	.38" UNF Lock Nut

VALVE ASSEMBLY

ASSEMBLY #2275

UNITS BUILT AFTER APRIL 1, 2014

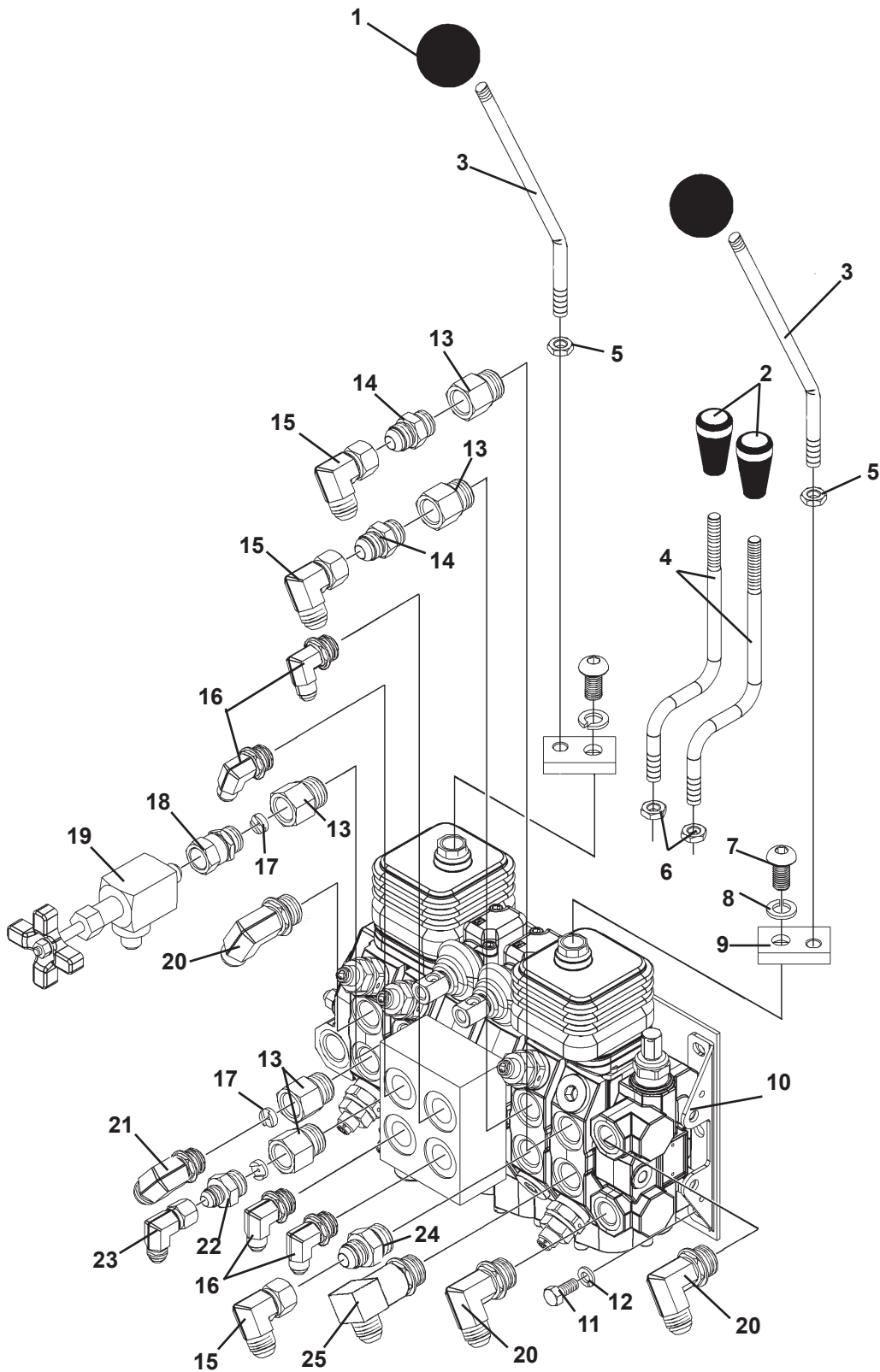

12747 4-23-14

VALVE ASSEMBLY

ASSEMBLY #2275

UNITS BUILT AFTER APRIL 1, 2014

<u>ITEM</u>	<u>REQ'D</u>	<u>PART NO.</u>	<u>DESCRIPTION</u>
1	2	83063	Knob
2	2	119155	Knob - Stabilizer
3	2	81871	Control Lever
4	2	119071	Stabilizer Control Lever
5	2	1242	.50" UNC Jam Nut
6	2	2558	M10 Hex Nut
7	2	119068	M12 Capscrew
8	2	2533	M12 Lock Washer
9	2	119153	Offset Bracket
10	1	45973	Bucher Valve
11	3	1021	.31" UNC X .75" Hex Capscrew
12	3	1502	.31" Lock Washer
13	5	30298	Straight Connector 8FBo-10MBo
14	2	3103	Straight Connector 8MBo-8MJ
15	3	3149	90° Elbow 8MJ-8FJX
16	4	30142	90° Elbow 6MJ - 8MBo
17	3	46004	Restrictor - .098
18	1	30192	Straight Connector 8MBo-6FJX
19	1	108112	Needle Valve
20	3	3283	90° Elbow 8MJ-10MBo
21	1	3104	90° Elbow 8MJ-8MBo
22	1	3269	Straight Connector 6MJ-8MBo
23	1	3430	90° Elbow 6MJ-6FJX
24	1	3270	Straight Connector 8MJ-10MBo
25	1	30068	90° Elbow - Long 8MJ-10MBo

VALVE ASSEMBLY

ASSEMBLY #2275

UNITS BUILT BEFORE APRIL 1, 2014

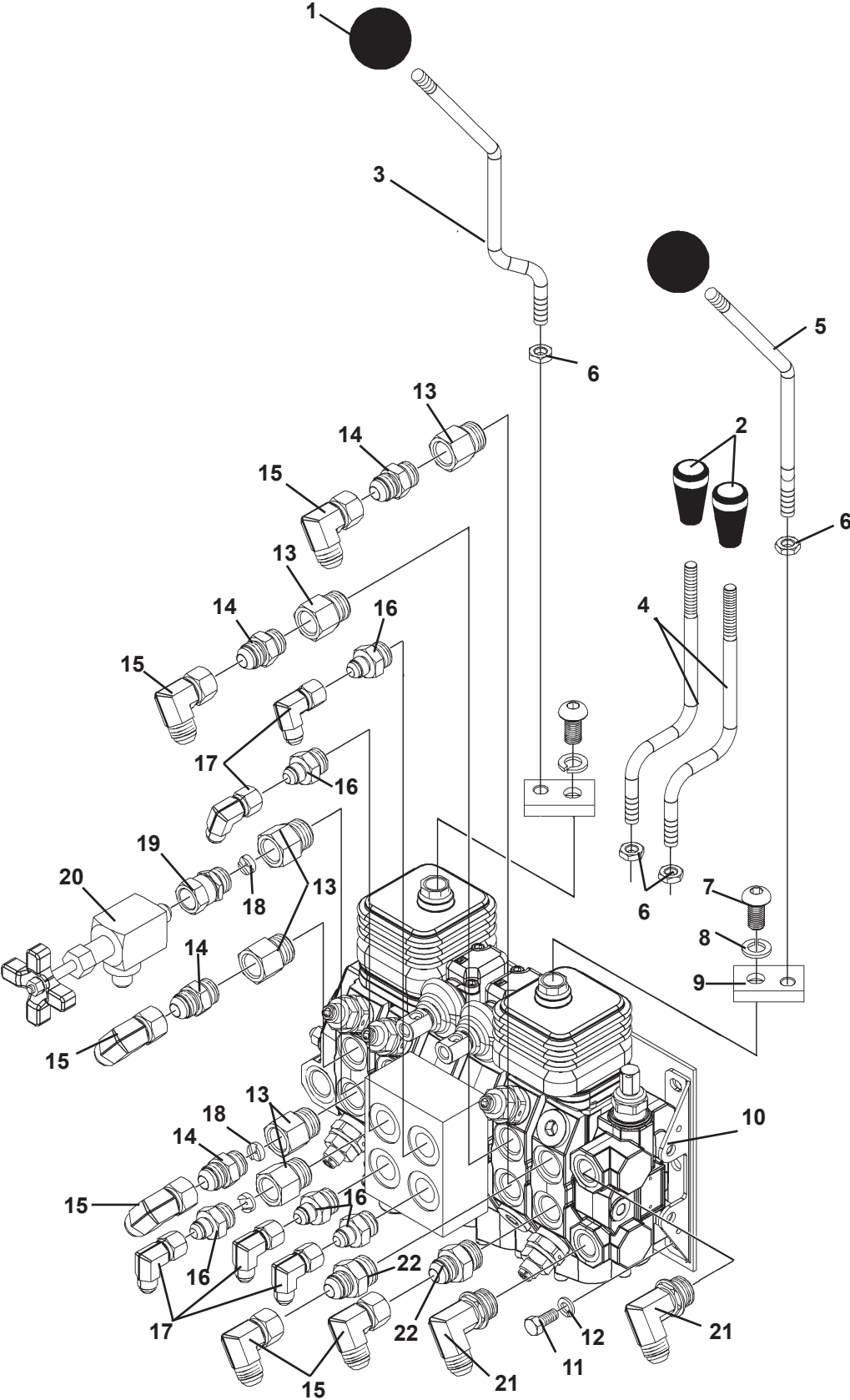

VALVE ASSEMBLY

ASSEMBLY #2275

UNITS BUILT BEFORE APRIL 1, 2014

<u>ITEM</u>	<u>REQ'D</u>	<u>PART NO.</u>	<u>DESCRIPTION</u>
1	2	85838	Knob
2	2	119155	Knob - Stabilizer
3	1	87951	Control Lever - Left
4	2	119071	Stabilizer Control Lever
5	1	87952	Control Lever - Right
6	4	2558	M10 Hex Nut
7	2	119068	M12 Capscrew
8	2	2533	M12 Lock Washer
9	2	119153	Offset Bracket
10	1	45973	Bucher Valve
11	3	1021	.31" UNC X .75" Hex Capscrew
12	3	1502	.31" Lock Washer
13	6	30298	Straight Connector 8FBo-10MBo
14	4	3103	Straight Connector 8MBo-8MJ
15	6	3149	90° Elbow 8MJ-8FJX
16	5	3269	Straight Connector 6MJ-8MBo
17	5	3430	90° Elbow 6MJ-6FJ
18	3	46004	Restrictor - .098
19	1	30192	Straight Connector 8MBo-6FJX
20	1	108112	Needle Valve
21	2	3283	90° Elbow 8MJ-10MBo
22	2	3270	Straight Connector 8MJ-10MBo

VALVE ASSEMBLY

BUCHER VALVE #45973 - SERVICE PARTS

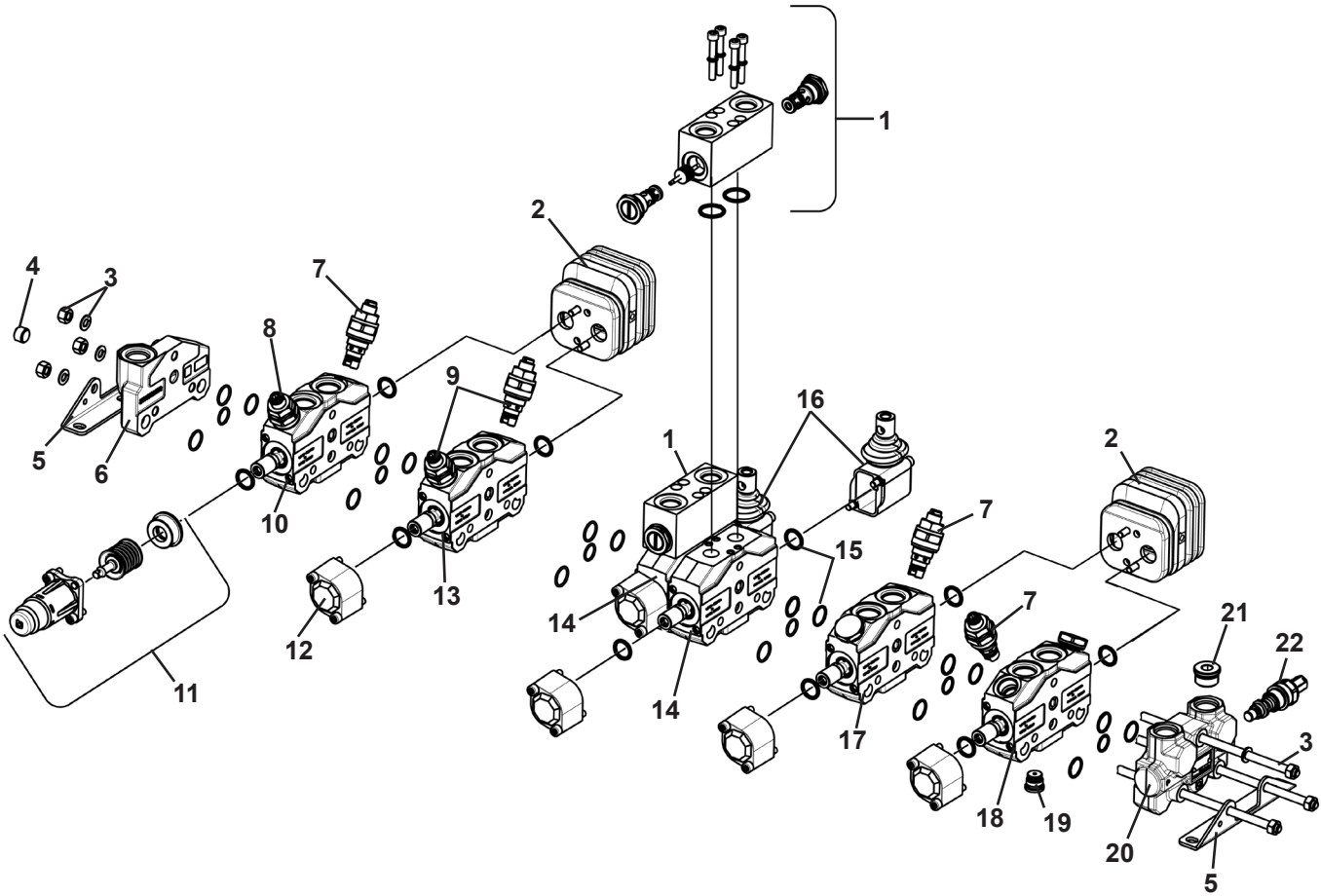
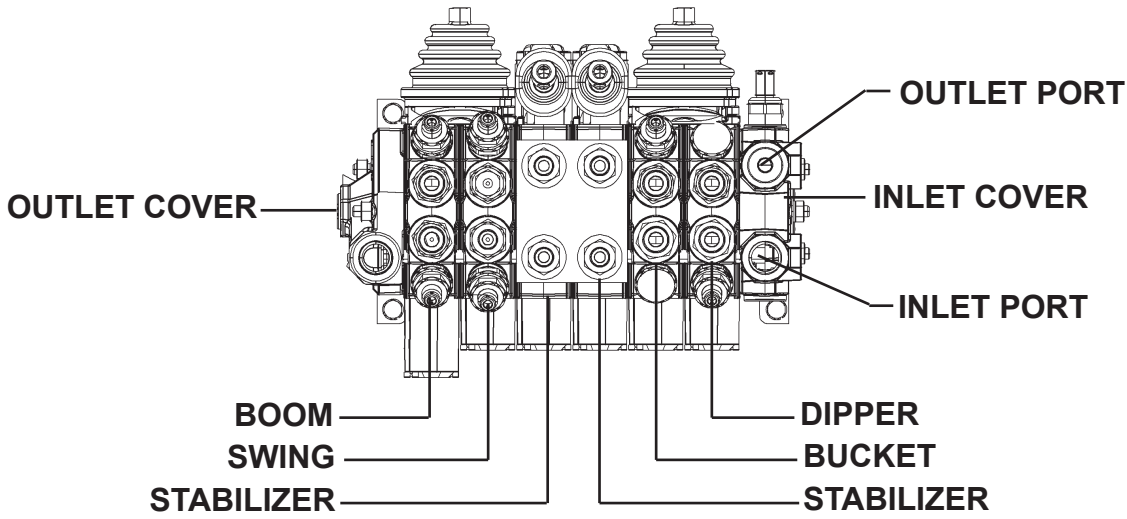

VALVE ASSEMBLY

BUCHER VALVE #45973 - SERVICE PARTS

<u>ITEM</u>	<u>PART NO.</u>	<u>DESCRIPTION</u>
1	46275	PO Check Valve Assembly (Includes: O'rings, Valve Body, Spool, Relief Valves & Hardware)
2	46273	Joystick Assembly
3	46281	Tie Rod (3 Required)
	2511	Flat Washer (4 Required)
	2556	Hex Nut (3 Required)
4	30326	Hex Socket Head Plug - 10MBo
	46261	Closed Center Power Beyond Plug
5	46280	Valve Mounting Bracket
6	46279	Outlet Section
7	46271	Relief Valve @ 2750 PSI (Boom, Bucket & Dipper Sections)
8	46272	Relief Valve @ 3250 PSI (Boom Section)
9	46270	Relief Valve @ 2500 PSI (Swing Section)
10	46277	Replacement Boom Section - Complete
11	46278	Float Positioner Assembly (Boom Section only)
12	46269	Positioner Assembly (Swing, Stabilizer, Bucket & Dipper Sections)
13	46268	Replacement Swing Section - Complete
14	46274	Replacement Stabilizer Section - Complete
15	46265	Section Seal Kit (Includes Spool Seals)
16	46276	Lever Cap
17	46267	Replacement Bucket Section - Complete
18	46266	Replacement Dipper Section - Complete
19	45922	Check Valve
20	46263	Inlet Section
21	30326	Hex Socket Head Plug - 10MBo
22	46264	Main Relief Valve @ 2750 PSI (Inlet Section)

CYLINDER ASSEMBLY

SWING CYLINDER ASSEMBLY #81022

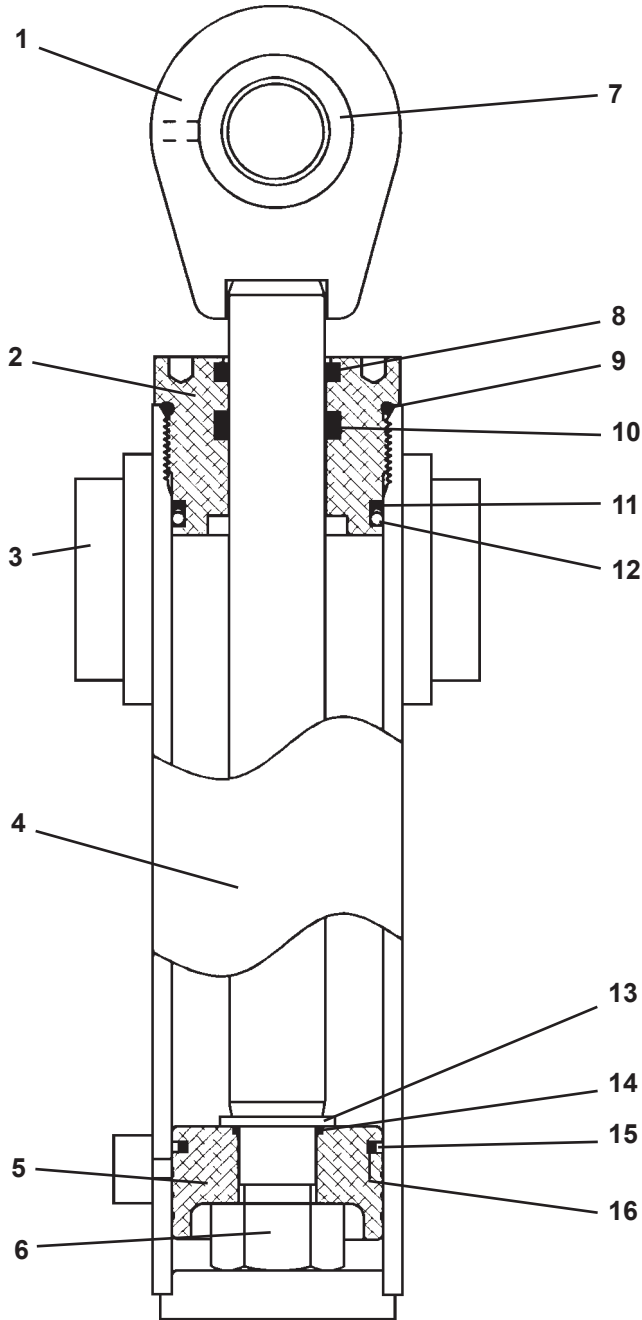

CYLINDER ASSEMBLY
 SWING CYLINDER ASSEMBLY #81022

<u>ITEM</u>	<u>REQ'D</u>	<u>PART NO.</u>	<u>DESCRIPTION</u>
1	1	81024	Cylinder Rod
2	1	77441	Cylinder Gland
3	2	82441	Needle Bearing
4	1	81023	Cylinder Tube
5	1	82578	Piston
6	1	1483	Hex Nut
7	1	62523	Self Aligning Bushing
8	1	45389*	Rod Wiper
9	1	4570*	O'Ring
10	1	45219*	Poly Pak Seal
11	1	45249*	Back-Up Ring
12	1	45557*	O'Ring
13	1	5421	Washer
14	1	4641*	O'Ring
15	1	45251*	Piston Ring
16	1	45250*	O'Ring

NOTE: Seal Kit #45551 Includes all parts marked with an asterisk (*). Parts are not sold separately.

CYLINDER ASSEMBLY

STABILIZER CYLINDER ASSEMBLY #82980

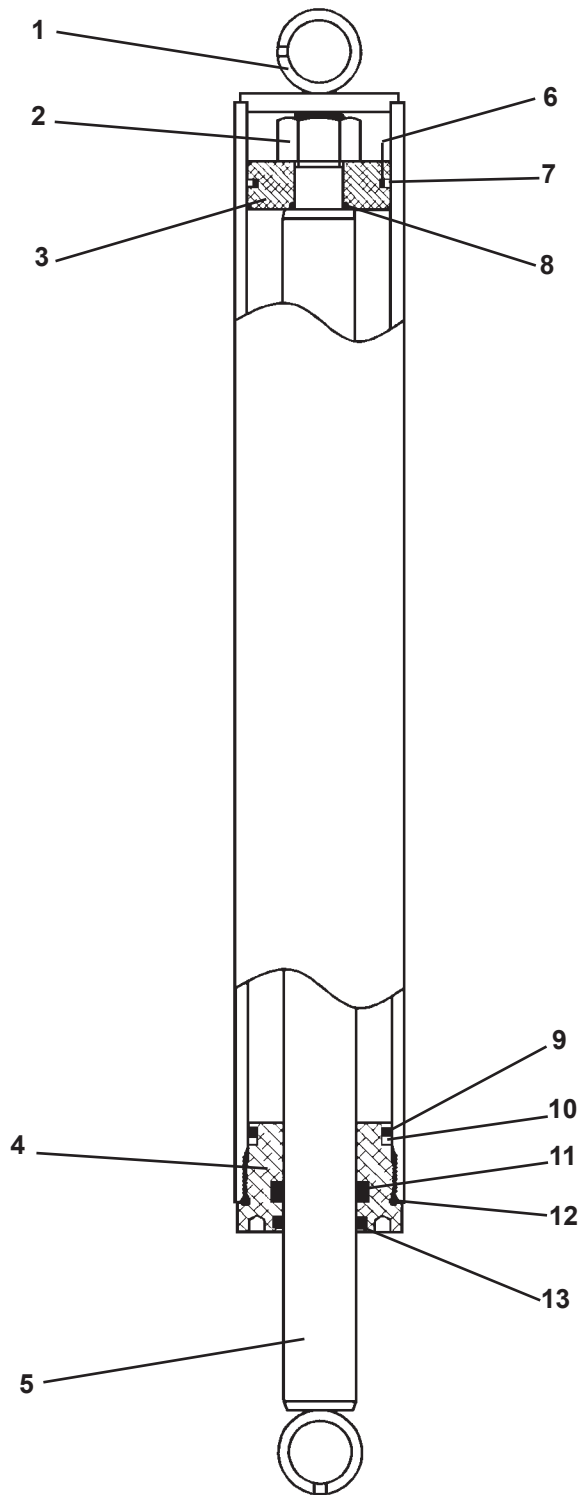

CYLINDER ASSEMBLY
 STABILIZER CYLINDER ASSEMBLY #82980

<u>ITEM</u>	<u>REQ'D</u>	<u>PART NO.</u>	<u>DESCRIPTION</u>
1	1	82981	Cylinder Tube
2	1	1483	Hex Nut
3	1	87170	Piston
4	1	77445	Cylinder Gland
5	1	82986	Cylinder Rod
6	1	45744*	O'Ring
7	1	45743*	Piston Ring
8	1	4641*	O'Ring
9	1	45555*	O'Ring
10	1	4631*	Back-Up Ring
11	1	45225*	Poly Pak Seal
12	1	4908*	O'Ring
13	1	45372*	Rod Wiper

NOTE: Seal Kit #45746 includes all parts marked with an asterisk (*). Parts are not sold separately.

CYLINDER ASSEMBLY

BOOM CYLINDER ASSEMBLY #82476

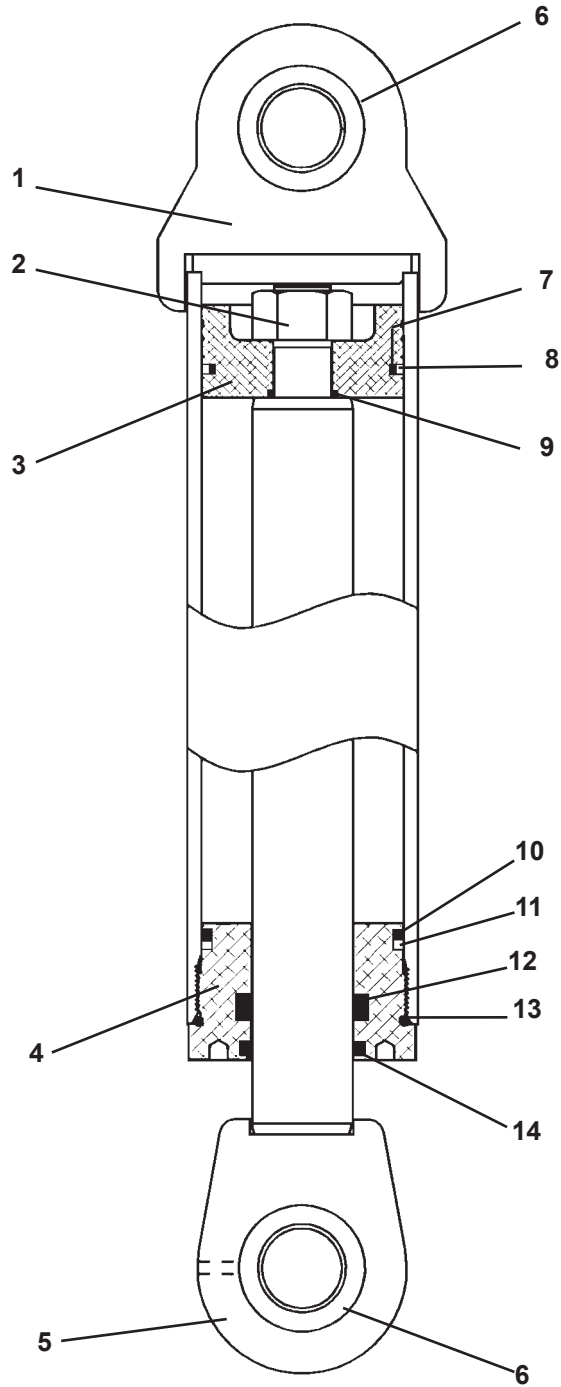

CYLINDER ASSEMBLY
BOOM CYLINDER ASSEMBLY #82476

<u>ITEM</u>	<u>REQ'D</u>	<u>PART NO.</u>	<u>DESCRIPTION</u>
1	1	82481	Cylinder Tube
2	1	1483	Hex Nut
3	1	82817	Piston
4	1	77451	Cylinder Gland
5	1	82482	Cylinder Rod
6	2	6615	Self Aligning Bushing
7	1	45245*	O'Ring
8	1	45244*	Piston Ring
9	1	4641*	O'Ring
10	1	45242*	O'Ring
11	1	45243*	Back-Up Ring
12	1	45119*	Poly Pak Seal
13	1	45412*	O'Ring
14	1	45370*	Rod Wiper

NOTE: Seal Kit #45415 includes all parts marked with an asterisk (*). Parts are not sold separately.

CYLINDER ASSEMBLY

DIPPER CYLINDER ASSEMBLY #85779

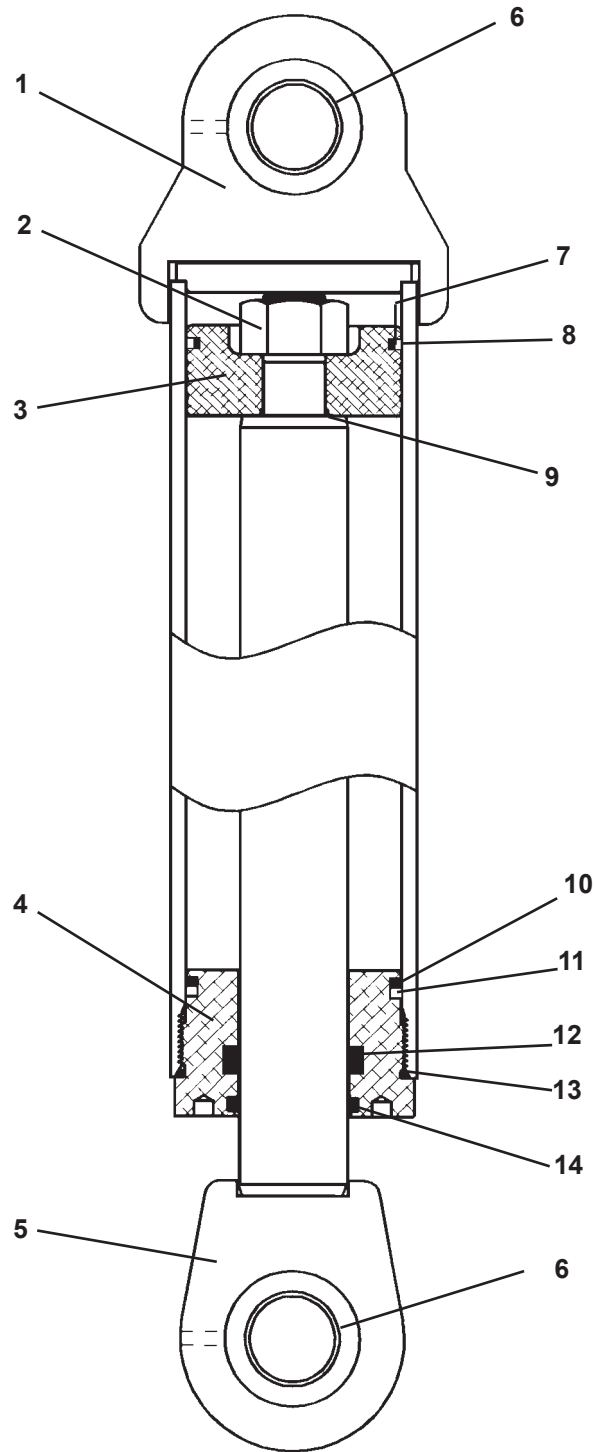

CYLINDER ASSEMBLY
 DIPPER CYLINDER ASSEMBLY #85779

<u>ITEM</u>	<u>REQ'D</u>	<u>PART NO.</u>	<u>DESCRIPTION</u>
1	1	85780	Cylinder Tube
2	1	1483	Hex Nut
3	1	85461	Piston
4	1	77451	Cylinder Gland
5	1	82495	Cylinder Rod
6	2	6615	Self Aligning Bushing
7	1	45245*	O'Ring
8	1	45244*	Piston Ring
9	1	4641*	O'Ring
10	1	45242*	O'Ring
11	1	45243*	Back-Up Ring
12	1	45119*	Poly Pak Seal
13	1	45412*	O'Ring
14	1	45370*	Rod Wiper

NOTE: Seal Kit #45415 includes all parts marked with an asterisk (*). Parts are not sold separately.

CYLINDER ASSEMBLY
BUCKET CYLINDER ASSEMBLY #117548

<u>ITEM</u>	<u>REQ'D</u>	<u>PART NO.</u>	<u>DESCRIPTION</u>
1	1	117549	Cylinder Tube (See Note)
2	1	1484	Hex Nut
3	1	55904	Piston
4	1	77444	Cylinder Gland
5	1	82506	Cylinder Rod
6	2	6615	Self Aligning Bushing
7	1	4570*	O'Ring
8	1	4569*	Piston Ring
9	1	4865*	O'Ring
10	1	45555*	O'Ring
11	1	4631*	Back-Up Ring
12	1	45117*	Poly Pak Seal
13	1	4908*	O'Ring
14	1	45364*	Rod Wiper

NOTE: Seal Kit #45547 includes all parts marked with an asterisk (*). Parts are not sold separately.

MAINFRAME HOSE SET

ASSEMBLY #82761

HYDRAULIC CONTROL VALVE

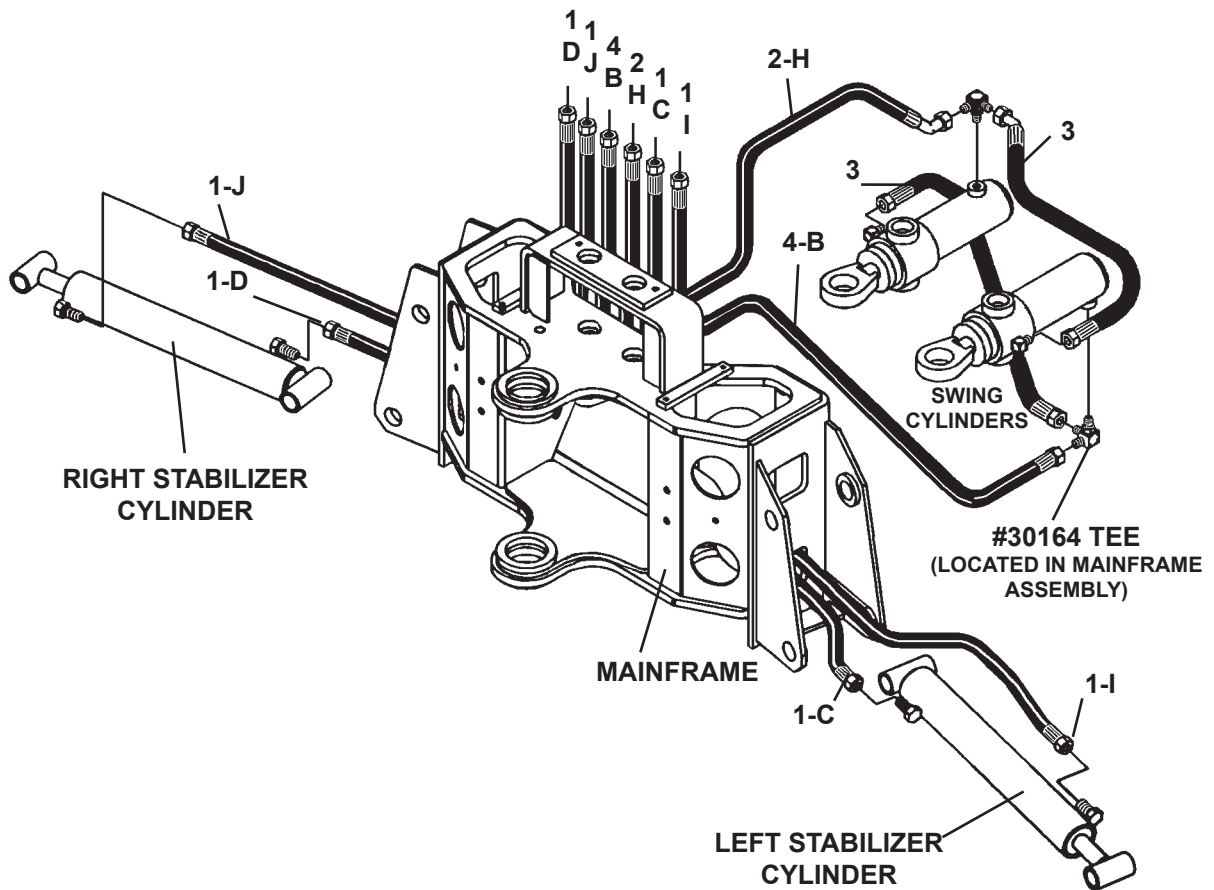
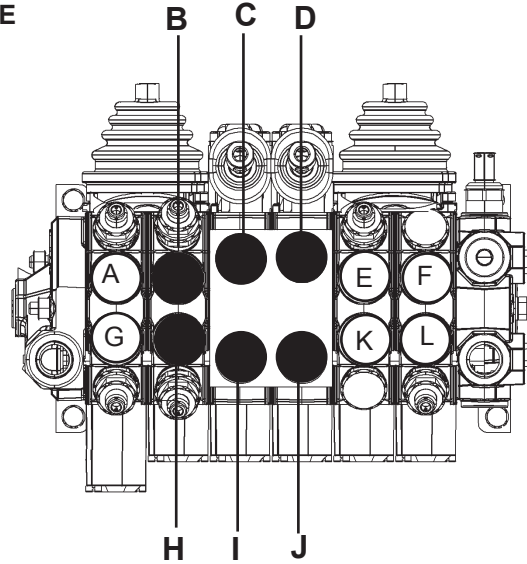

MAINFRAME HOSE SET

ASSEMBLY #82761

<u>ITEM</u>	<u>REQ'D</u>	<u>PART NO.</u>	<u>DESCRIPTION</u>
1	4	37553	Hose Assembly .25" X 58" 6FJX-6FJX
2	1	38360	Hose Assembly .25" X 13.50" 6FJX-6FJX 90° Gooseneck
3	2	37552	Hose Assembly .25" X 14.50" 6FJX-6FJX
4	1	37699	Hose Assembly .25" X 19.00" 6FJX-6FJX

NOTE: Refer to the mainframe assembly for the priority valve hoses which are included in this assembly but have been shown in the mainframe assembly for clarity.

NOTE: Letters on the hose set diagram show the hydraulic hose routing between the backhoe control valve and the various hydraulic cylinders. Simply match the letter on the control valve port to the same letter on the hydraulic hose ends. Example: Hose Assembly labeled "C" runs from the upper Left Stabilizer port on the hydraulic control valve - through the mainframe and to the barrel end fitting on the left stabilizer cylinder.

NOTE: The fittings on the hydraulic cylinders have been altered for clarity purposes. This will assist you in distinguishing between the rod end and the barrel end of the various hydraulic cylinders.

12616 4-18-14-2

BOOM & DIPPER HOSE SET

ASSEMBLY #82763

HYDRAULIC CONTROL VALVE

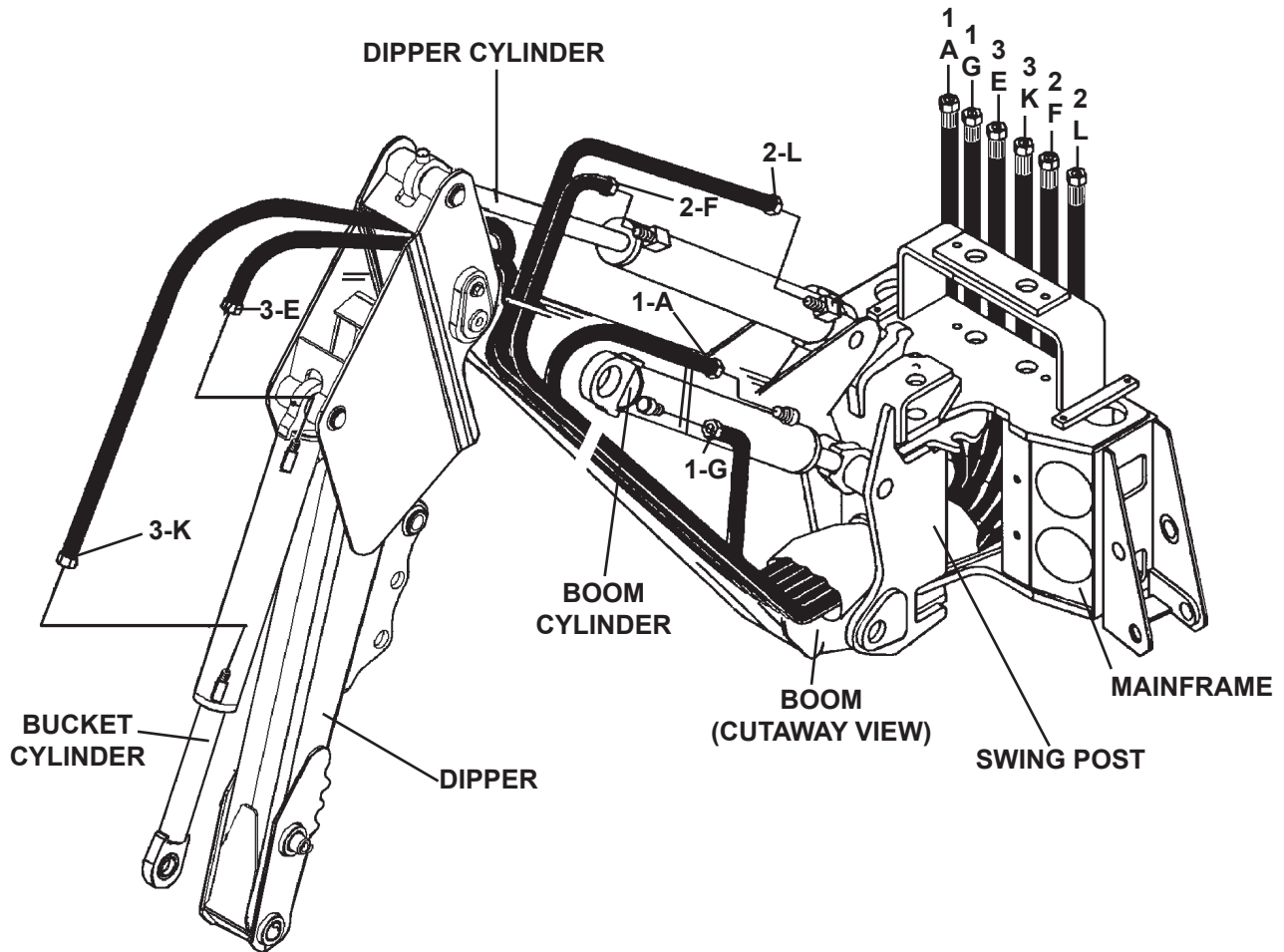
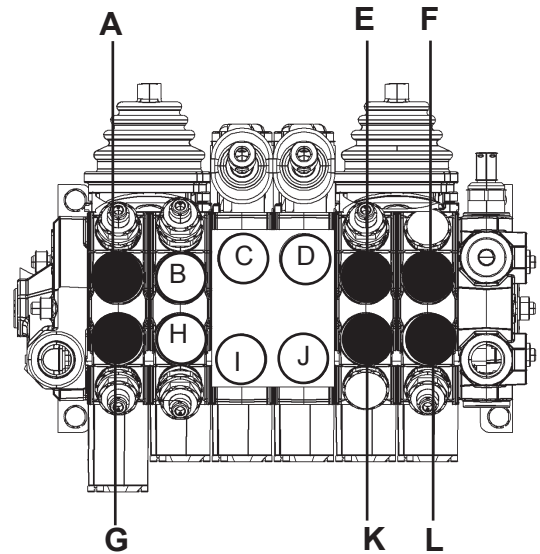

12617 1-8-14

BOOM & DIPPER HOSE SET

ASSEMBLY #82763

<u>ITEM</u>	<u>REQ'D</u>	<u>PART NO.</u>	<u>DESCRIPTION</u>
1	2	37558	Hose Assembly .38" X 93" 8FJX-8FJX
2	2	37559	Hose Assembly .38" X 157" 8FJX-8FJX
3	2	37559	Hose Assembly .38" X 157" 8FJX-8FJX

NOTE: Letters on the hose set diagram show the hydraulic hose routing between the backhoe control valve and the various hydraulic cylinders. Simply match the letter on the control valve port to the same letter on the hydraulic hose ends. Example: Hose Assembly labeled "G" runs from the lower Boom port on the hydraulic control valve - through the mainframe and swing post and to the barrel end of the boom cylinder.

NOTE: The fittings on the hydraulic cylinders have been altered for clarity purposes. This will assist you in distinguishing between the rod end and the barrel end of the various hydraulic cylinders.

STABILIZER PADS

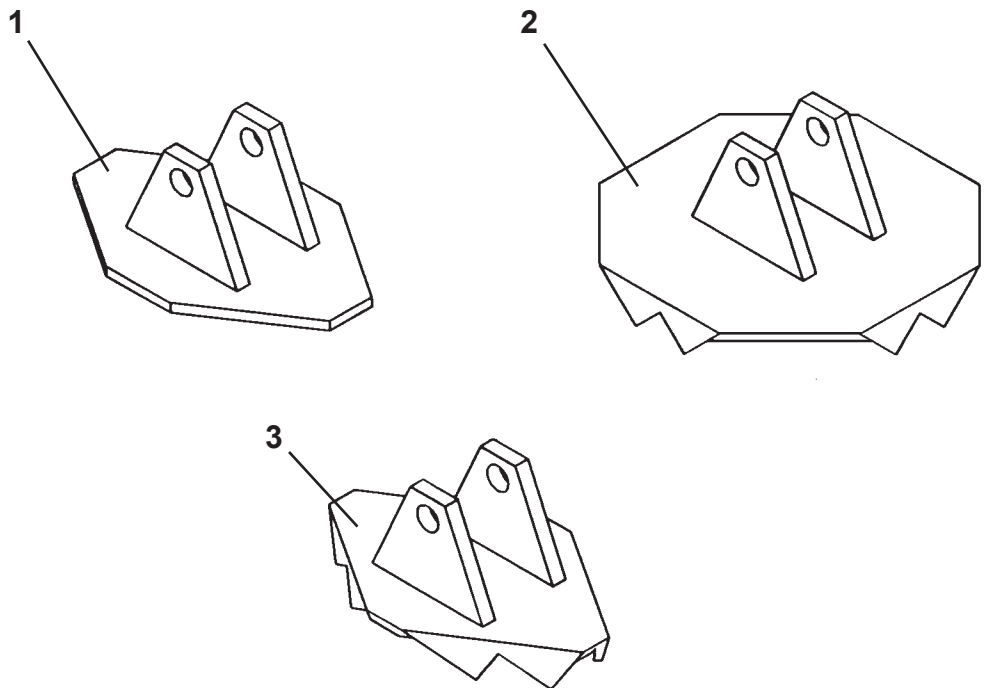

4

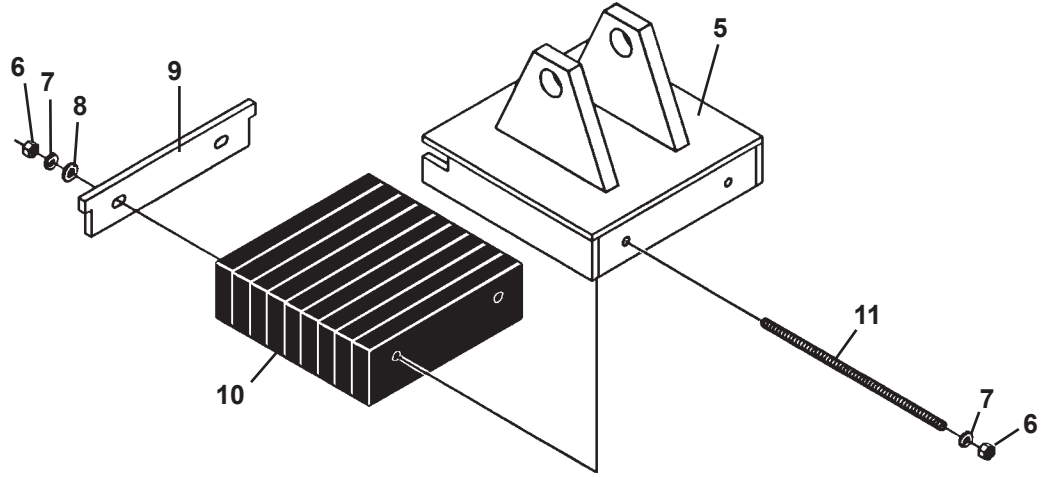

STABILIZER PADS

FLAT STABILIZER PAD ASSEMBLY - #83055

<u>NO</u>	<u>REQ'D</u>	<u>PART NO.</u>	<u>DESCRIPTION</u>
1	2	83079	Flat Stabilizer Pad

LARGE GROUSER PAD ASSEMBLY - #83057

<u>NO</u>	<u>REQ'D</u>	<u>PART NO.</u>	<u>DESCRIPTION</u>
2	2	83086	Large Grouser Pad

GROUSER PAD ASSEMBLY - #83054

<u>NO</u>	<u>REQ'D</u>	<u>PART NO.</u>	<u>DESCRIPTION</u>
3	2	83059	Grouser Stabilizer Pad

RUBBER STABILIZER PAD ASSEMBLY - #83056

<u>NO</u>	<u>REQ'D</u>	<u>PART NO.</u>	<u>DESCRIPTION</u>
4	2	83084	Rubber Stabilizer Pad Assembly (Includes Items 5 through 11)
5	1	83085	Stabilizer Pad
6	4	1226	.38" UNC Hex Nut
7	4	1503	.38" Lock Washer
8	2	1514	.38" Flat Washer
9	1	51190	Slide Plate
10	1	64412	Rubber Strip Bundle
11	2	1661	.38" UNC X 11.50" Readi Bolt

STABILIZER PADS

FLIP-OVER STABILIZER PAD ASSEMBLY #83091
(COMPLETE SET OF (2) FLIP-OVER PADS - ASSEMBLY #83058)

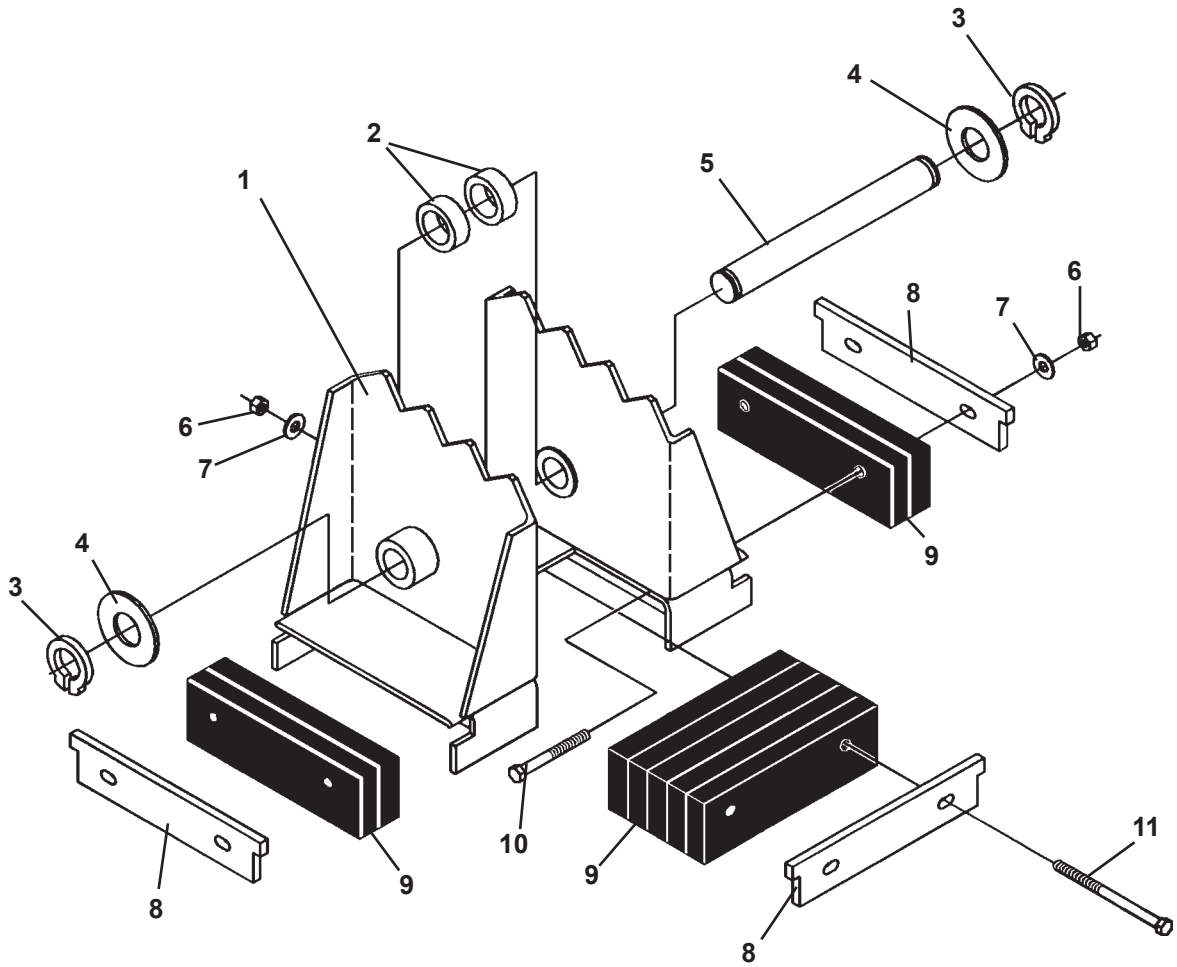

STABILIZER PADS

FLIP-OVER STABILIZER PAD ASSEMBLY #83091
(COMPLETE SET OF (2) FLIP-OVER PADS - ASSEMBLY #83058)

<u>ITEM</u>	<u>REQ'D</u>	<u>PART NO.</u>	<u>DESCRIPTION</u>
1	1	84496	Flip-Over Pad
2	2	84495	Spacer
3	2	1652	1.25" Snap Ring
4	VARIABLES	57693	Thrust Washer 1.25" X .078"
	VARIABLES	64727	Thrust Washer 1.25" X .125"
5	1	83096	Pin
6	6	1837	.38" UNC Hex Deformed Lock Nut
7	6	1514	.38" Flat Washer
8	3	51190	Slide Plate
9	1	64412	Rubber Strip Bundle
10	4	1053	.38" UNC X 3.50" Hex Capscrew
11	2	1057	.38" UNC X 5.00" Hex Capscrew

OPTIONAL STABILIZER CYLINDER COVER

ASSEMBLY #86706

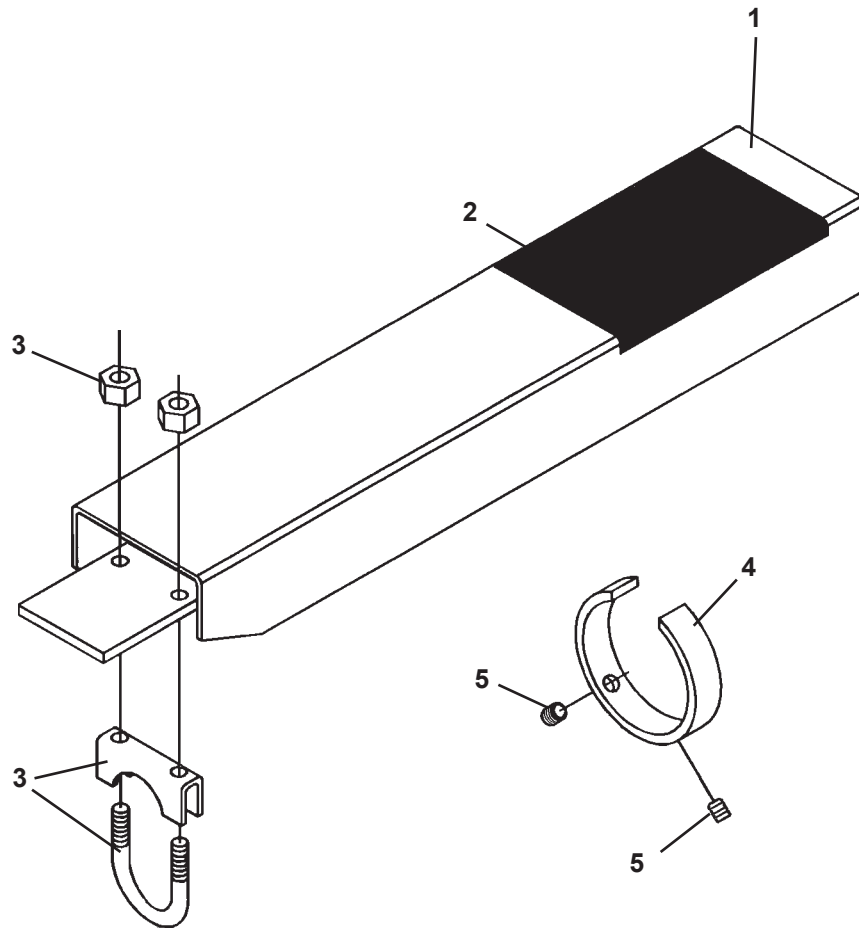

OPTIONAL STABILIZER CYLINDER COVER

ASSEMBLY #86706

<u>ITEM</u>	<u>REQ'D</u>	<u>PART NO.</u>	<u>DESCRIPTION</u>
1	2	83915	Stabilizer Cylinder Cover with Decal
2	2	4167	No Step Decal
3	2	83906	1.50" Clamp Assembly
4	2	83911	Guide Ring
5	4	1575	.38" UNC X .50" Set Screw

BUCKET ASSEMBLIES

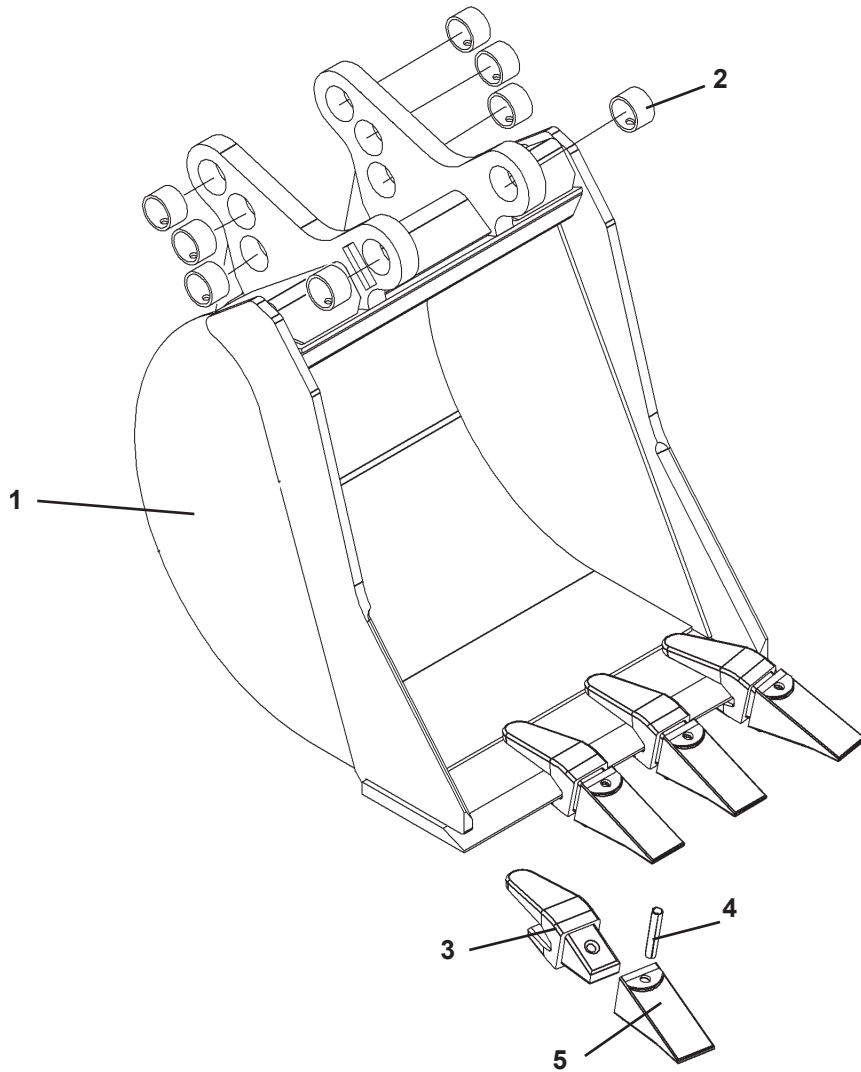

BUCKET ASSEMBLIES

<u>ITEM</u>	<u>REQ'D</u>	<u>PART NO.</u>	<u>DESCRIPTION</u>
1	-	110012	12" Bucket (Includes Teeth and Bushings)
		110016	16" Bucket (Includes Teeth and Bushings)
		110018	18" Bucket (Includes Teeth and Bushings)
		110020	20" Bucket (Includes Teeth and Bushings)
		110024	24" Bucket (Includes Teeth and Bushings)
		110034	34" Bucket (Includes Teeth and Bushings)
		110036	36" Bucket (Includes Teeth and Bushings)
		110038	38" Bucket (Includes Teeth and Bushings)
2	8	6355	Replacement Bushing
3	Varies	74228*	Replacement Tooth Shank (Weld On)
4	Varies	74227*	Replacement Spiral Roll Pin
5	Varies	84863*	Replacement Tooth (Bolt On)

BUCKET SPECIFICATIONS				
BUCKET SIZE	TOOTH QTY	WEIGHT	STRUCK CAPACITY	RATED CAPACITY
12	3	125 LBS.	1.25 CU. FT.	1.53 CU. FT.
16	4	148 LBS.	1.72 CU. FT.	2.20 CU. FT.
18	4	156 LBS.	1.95 CU. FT.	2.54 CU. FT.
20	4	165 LBS.	2.16 CU. FT.	2.81 CU. FT.
24	4	180 LBS.	2.65 CU. FT.	3.57 CU. FT.
34	7	238 LBS.	3.82 CU. FT.	5.31 CU. FT.
36	7	246 LBS.	4.05 CU. FT.	5.56 CU. FT.
38	7	255 LBS.	1.28 CU. FT.	5.99 CU. FT.

NOTE: Tooth and Shank Assembly #85003 includes one each of all parts marked with an asterisk (*).

FIRST LINE REPAIR KIT

ASSEMBLY #83759

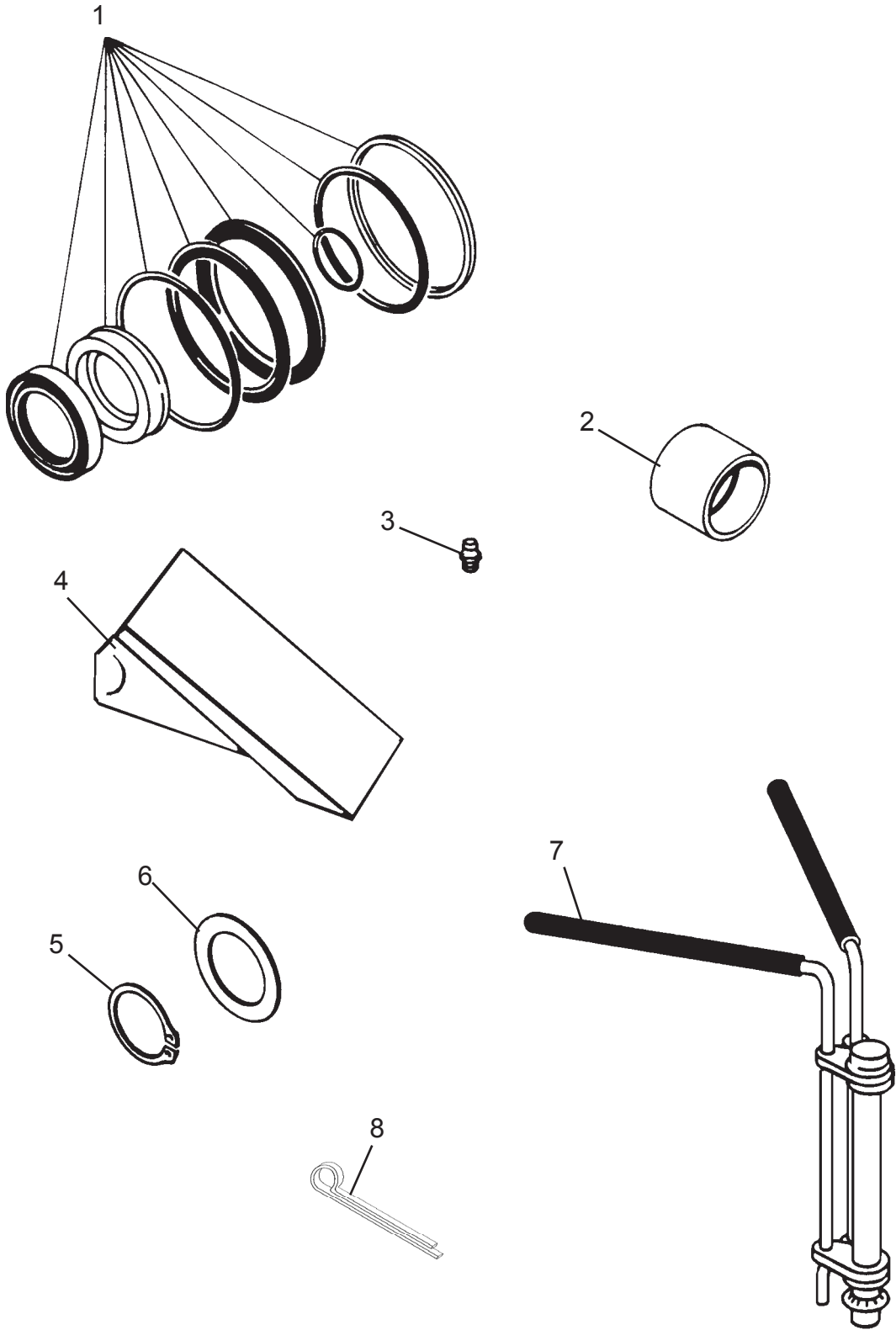

6876
6-22-99-2

FIRST LINE REPAIR KIT

ASSEMBLY #83759

<u>NO</u>	<u>REQ'D</u>	<u>PART NO.</u>	<u>DESCRIPTION</u>
1	2	45415	Seal Kit (Boom/Dipper Cylinder)
	1	45547	Seal Kit (Bucket Cylinder)
	1	45550	Seal Kit (Stabilizer Cylinders)
	1	45551	Seal Kit (Swing Cylinder)
2	2	81610	Bushing
	2	6355	Bushing
3	4	6616	Grease Zerk
4	4	84863	Severe Duty Bucket Tooth
5	4	1650	Snap Ring 1.38"
6	4	6623	Thrust Washer 1.38" X .031"
7	1	65349	Cylinder Seal Install Tool
8	2	1613	Cotter Pin

6877
6-22-99-2

DECALS

DECAL PLACEMENT

GENERAL INFORMATION

The diagrams on this page shows the location of all the decals used on the backhoes. The decals are identified by their part numbers, with reductions of the actual decals located on the following pages. Use this information to order replacements for lost or damaged decals. Be sure to read all decals before operating the backhoe. They contain information you need to know for both safety and backhoe longevity.

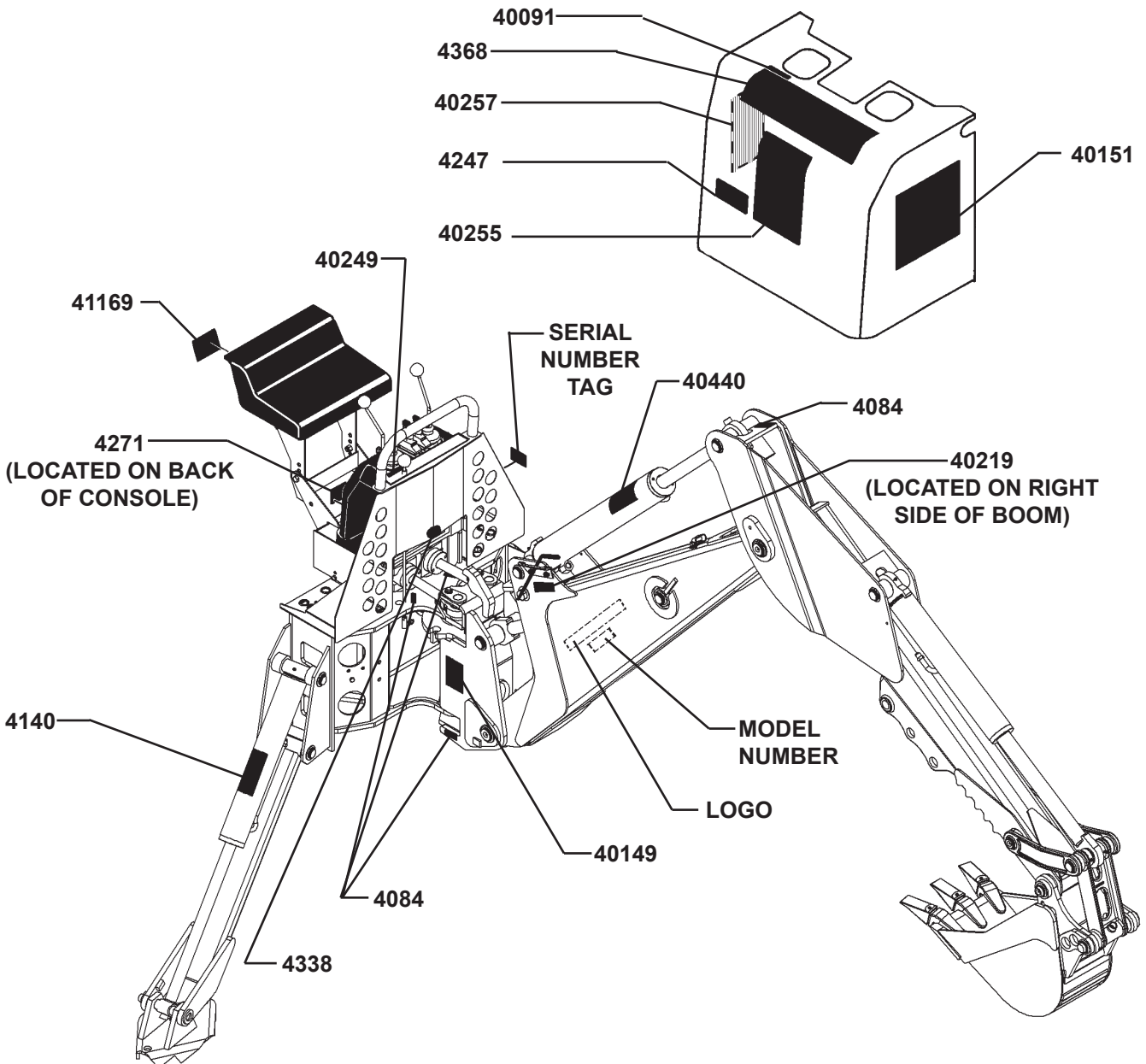

IMPORTANT: Keep all safety decals clean and legible. Replace all missing, illegible or damaged safety decals. When replacing parts with safety decals attached, the safety decals must also be replaced.

REPLACING SAFETY DECALS: Clean the area of application with a nonflammable solvent, then wash the same area with soap and water. Allow the surface to dry. Remove the backing from the safety decal, exposing the adhesive surface. Apply the safety decal to the position shown in the diagram, and smooth out any bubbles.

12592 11-25-13

DECALS

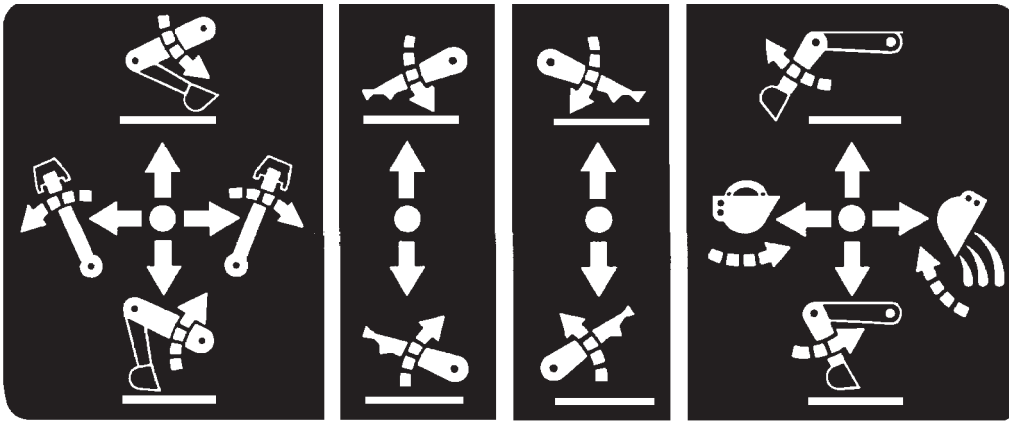

PART #4368
OPERATING CONTROLS DECAL

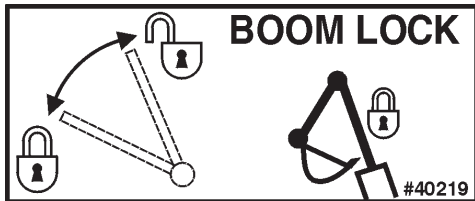

PART #40219
BOOM LOCK DECAL

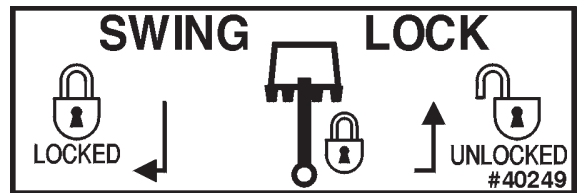

PART #40249
SWING LOCK DECAL

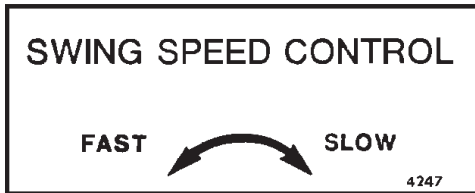

PART #4247
SWING SPEED CONTROL DECAL

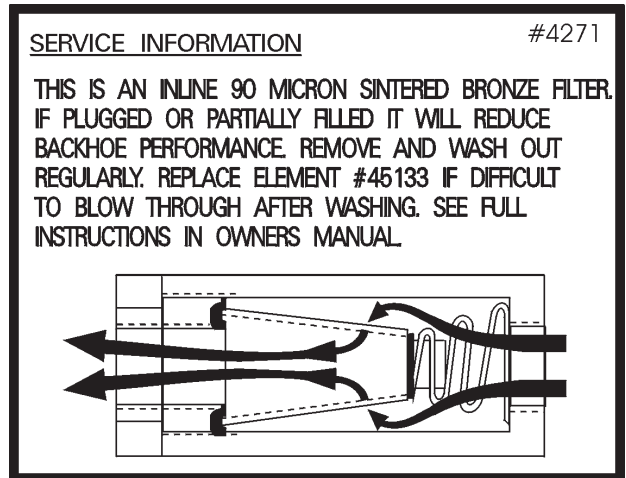

PART #4271
INLINE FILTER DECAL



PART #40091
FLOAT DECAL

NOTE: CONTACT PALADIN OR YOUR LOCAL DEALER FOR MODEL NUMBER AND LOGO DECALS.

DECALS

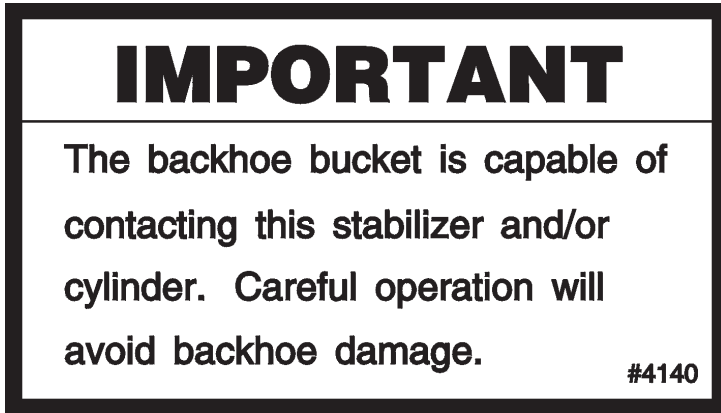

PART #4140
BUCKET CONTACT WARNING DECAL



PART #4338
MADE IN U.S.A. DECAL



PART #40440
CALL BEFORE YOU DIG



PART #4084
GREASE 8 HOURS

DECALS

 WARNING		
		
HIGH-PRESSURE FLUID HAZARD		
To prevent serious injury or death:		
<ul style="list-style-type: none"> • Relieve pressure on system before repairing or adjusting or disconnecting. • Wear proper hand and eye protection when searching for leaks. Use wood or cardboard instead of hands. • Keep all components in good repair. 		

PART #40151
HIGH PRESSURE FLUID DECAL

 DANGER	
	<p>To Prevent Serious Injury or Death from Crushing:</p> <p>Verify the backhoe is securely attached to the prime mover.</p> <ul style="list-style-type: none"> • Check mounting bolts for tightness. • Visually check for proper pin engagement before operating. <p>#41169</p>

PART #41169
DANGER! BACKHOE SECURE

IMPORTANT
<p>TO PREVENT BACKHOE DAMAGE:</p> <ul style="list-style-type: none"> • DO NOT ATTACH TOW CHAIN TO DIPPER OR BUCKET. • DO NOT REPEATEDLY SLAM SWING POST INTO SWING STOPS. <p>PREPARATION FOR STORAGE</p> <p>LUBRICATE ALL GREASE POINTS. LEAVE AS MANY CYLINDERS IN CLOSED POSITION AS POSSIBLE. COVER ALL EXPOSED CYLINDER RODS WITH A LIGHT COAT OF GREASE.</p> <p>#40257</p>

PART #40257
IMPORTANT! DECAL

 WARNING	
TO PREVENT SERIOUS INJURY OR DEATH:	
<ul style="list-style-type: none"> • Do not operate or work on this machine without reading and understanding Operator's Manual. • Avoid unsafe operation or maintenance. • Do not operate machine with guards and covers removed. • This machine was designed to be operated by one operator. Do not carry passengers on unit. • Before installing backhoe on your unit extend boom and dipperstick and lower bucket to ground. • Never use backhoe as manlift. • Operate backhoe control levers from operator's seat only. Lower stabilizers and bucket to ground before leaving operator's seat. • Engage boom lock and swing lock before transporting backhoe. 	
#40255	

PART #40255
OPERATIONAL WARNING DECAL

 DANGER		
		
<p>To prevent serious injury or death from pinching:</p> <ul style="list-style-type: none"> • Keep all persons and objects clear while any part of this machine is in motion. 		

PART #40149
DANGER! PINCH POINTS