

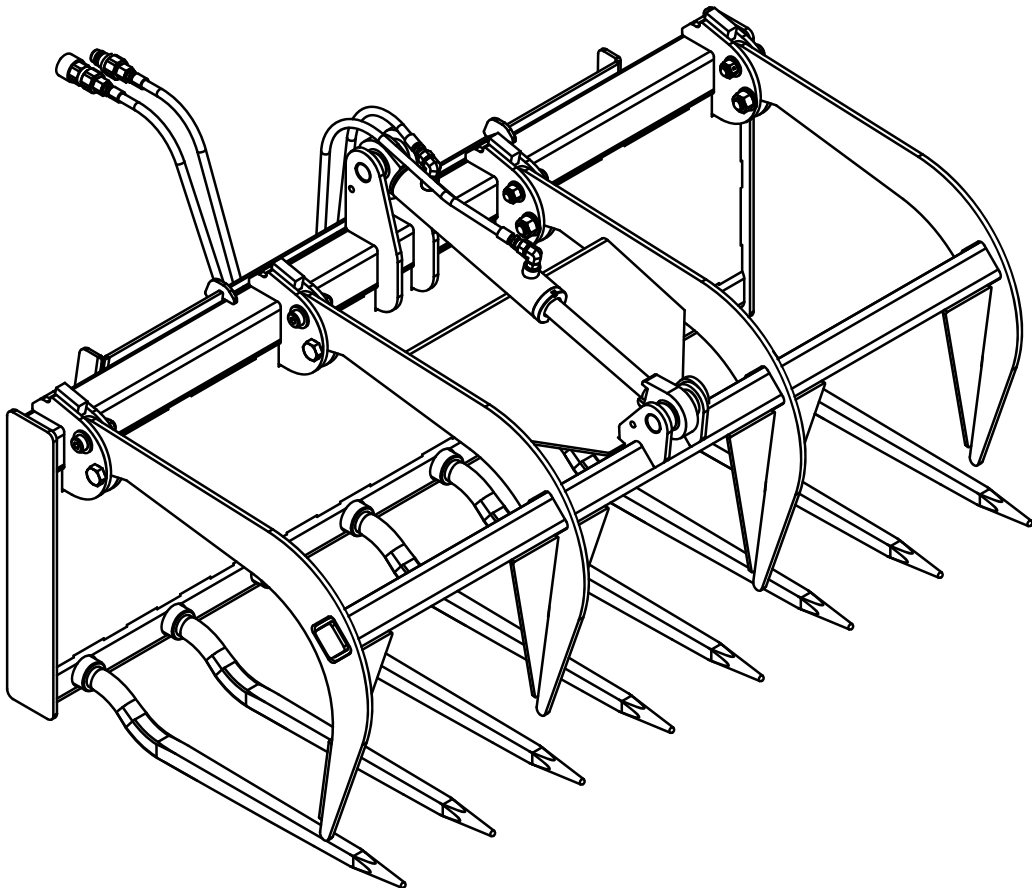

OPERATOR'S AND PARTS MANUAL

MANURE FORK & GRAPPLE



SERIAL NUMBER: _____

MODEL NUMBER: _____

Manual Number: 51-10031

Part Number:

10708 Manure Fork with Grapple

10718 Manure Fork Only

10728 Grapple Only

Rev. 4

TABLE OF CONTENTS

PREFACE	2
SAFETY PRECAUTIONS	
SAFETY STATEMENTS	3
SAFETY PRECAUTIONS	3-5
EQUIPMENT SAFETY PRECAUTIONS	6-7
DECALS	8-9
INSTALLATION	10
OPERATION	11-12
MAINTENANCE	13
MAINTENANCE LOG	14
SPECIFICATIONS	15
BOLT TORQUE SPECIFICATIONS.....	16
WARRANTY.....	17
PARTS.....	18-19

PREFACE

GENERAL COMMENTS

Congratulations on the purchase of your new attachment! This product was carefully designed and manufactured to give you many years of dependable service. Only minor maintenance (such as cleaning and lubricating) is required to keep it in top working condition. Be sure to observe all maintenance procedures and safety precautions in this manual and on any safety decals located on the product and on any equipment on which the attachment is mounted.

This manual has been designed to help you do a better, safer job. Read this manual carefully and become familiar with its contents.

WARNING! Never let anyone operate this unit without reading the "Safety Precautions" and "Operating Instructions" sections of this manual.



Always choose hard, level ground to park the vehicle on and set the brake so the unit cannot roll.

Unless noted otherwise, right and left sides are determined from the operator's control position when facing the attachment.

NOTE: The illustrations and data used in this manual were current (according to the information available to us) at the time of printing, however, we reserve the right to redesign and change the attachment as may be necessary without notification.

BEFORE OPERATION

The primary responsibility for safety with this equipment falls to the operator. Make sure the equipment is operated only by trained individuals that have read and understand this manual. If there is any portion of this manual or function you do not understand, contact your local authorized dealer or the manufacturer to obtain further assistance. Keep this manual available for reference. Provide the manual to any new owners and/or operators.

SAFETY ALERT SYMBOL



This is the "Safety Alert Symbol" used by this industry. This symbol is used to warn of possible injury. Be sure to read all warnings carefully. They are included for your safety and for the safety of others working with you.

SERVICE

Use only manufacturer replacement parts. Substitute parts may not meet the required standards.

Record the model and serial number of your unit on the cover of this manual. The parts department needs this information to insure that you receive the correct parts.

SOUND AND VIBRATION

Sound pressure levels and vibration data for this attachment are influenced by many different parameters: some items are listed below (not inclusive):

- prime mover type, age, condition, with or without cab enclosure and configuration
- operator training, behavior, stress level
- job site organization, working material condition, environment

Based on the uncertainty of the prime mover, operator, and job site, it is not possible to get precise machine and operator sound pressure levels or vibration levels for this attachment.

NOTE: A list of all Paladin Patents can be found at <http://www.paladinattachments.com/patents.asp>.

SAFETY STATEMENTS



THIS SYMBOL BY ITSELF OR WITH A WARNING WORD THROUGHOUT THIS MANUAL IS USED TO CALL YOUR ATTENTION TO INSTRUCTIONS INVOLVING YOUR PERSONAL SAFETY OR THE SAFETY OF OTHERS. FAILURE TO FOLLOW THESE INSTRUCTIONS CAN RESULT IN INJURY OR DEATH.



DANGER

THIS SIGNAL WORD IS USED WHERE SERIOUS INJURY OR DEATH WILL RESULT IF THE INSTRUCTIONS ARE NOT FOLLOWED PROPERLY.



WARNING

THIS SIGNAL WORD IS USED WHERE SERIOUS INJURY OR DEATH COULD RESULT IF THE INSTRUCTIONS ARE NOT FOLLOWED PROPERLY.



CAUTION

THIS SIGNAL WORD IS USED WHERE MINOR INJURY COULD RESULT IF THE INSTRUCTIONS ARE NOT FOLLOWED PROPERLY.

NOTICE

NOTICE INDICATES A PROPERTY DAMAGE MESSAGE.

GENERAL SAFETY PRECAUTIONS

WARNING! READ MANUAL PRIOR TO INSTALLATION



Improper installation, operation, or maintenance of this equipment could result in serious injury or death. Operators and maintenance personnel should read this manual, as well as all manuals related to this equipment and the tractor thoroughly before beginning installation, operation, or maintenance. **FOLLOW ALL SAFETY INSTRUCTIONS IN THIS MANUAL AND THE TRACTOR'S MANUAL(S).**



READ AND UNDERSTAND ALL SAFETY STATEMENTS

Read all safety decals and safety statements in all manuals prior to operating or working on this equipment. Know and obey all OSHA regulations, local laws, and other professional guidelines for your operation. Know and follow good work practices when assembling, maintaining, repairing, mounting, removing, or operating this equipment.



KNOW YOUR EQUIPMENT

Know your equipment's capabilities, dimensions and operations before operating. Visually inspect your equipment before you start, and never operate equipment that is not in proper working order with all safety devices intact. Check all hardware to ensure it is tight. Make certain that all locking pins, latches, and connection devices are properly installed and secured. Remove and replace any damaged, fatigued, or excessively worn parts. Make certain all safety decals are in place and are legible. Keep decals clean, and replace them if they become worn and hard to read.

GENERAL SAFETY PRECAUTIONS

WARNING! PROTECT AGAINST FLYING DEBRIS



Always wear proper safety glasses, goggles or a face shield when driving pins in or out, or when any operation causes dust, flying debris, or any other hazardous material.

WARNING! LOWER OR SUPPORT RAISED EQUIPMENT



Do not work under raised booms without supporting them. Do not use support material made of concrete blocks, logs, buckets, barrels or any other material that could suddenly collapse or shift positions. Make sure support material is solid, not decayed, warped, twisted, or tapered. Lower booms to ground level or onto blocks. Lower booms and attachments to the ground before leaving the cab or operator's station.

WARNING! USE CARE WITH HYDRAULIC FLUID PRESSURE



Hydraulic fluid under pressure can penetrate the skin and cause serious injury or death. Hydraulic leaks under pressure may not be visible. Before connecting or disconnecting hydraulic hoses, read your tractor's operator's manual for detailed instructions on connecting and disconnecting hydraulic hoses or fittings.

- Keep unprotected body parts, such as face, eyes, and arms as far away as possible from a suspected leak. Flesh injected with hydraulic fluid may develop gangrene or other permanent disabilities.
- If injured by injected fluid, see a doctor at once. If your doctor is not familiar with this type of injury, ask him to research immediately to determine proper treatment.
- Wear safety glasses, protective clothing, and use a sound piece of cardboard or wood when searching for hydraulic leaks. **DO NOT USE YOUR HANDS!** **SEE ILLUSTRATION.**

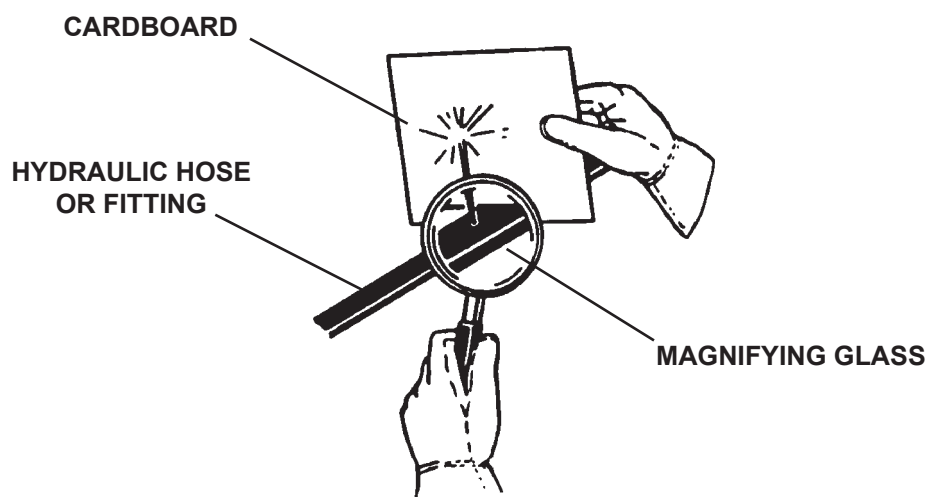

GENERAL SAFETY PRECAUTIONS

WARNING! DO NOT MODIFY MACHINE OR ATTACHMENTS



Modifications may weaken the integrity of the attachment and may impair the function, safety, life, and performance of the attachment. When making repairs, use only the manufacturer's genuine parts, following authorized instructions. Other parts may be substandard in fit and quality. Never modify any ROPS (Roll Over Protection Structure) or FOPS (Falling Object Protective Structure) equipment or device. Any modifications must be authorized in writing by the manufacturer.

WARNING! SAFELY MAINTAIN AND REPAIR EQUIPMENT



- Do not wear loose clothing, or any accessories that can catch in moving parts. If you have long hair, cover or secure it so that it does not become entangled in the equipment.
- Work on a level surface in a well-lit area.
- Use properly grounded electrical outlets and tools.
- Use the correct tool for the job at hand. Make sure they are in good condition for the task required.
- Wear the protective equipment specified by the tool manufacturer.

WARNING! SAFELY OPERATE EQUIPMENT



Do not operate equipment until you are completely trained by a qualified operator in how to use the controls, know its capabilities, dimensions, and all safety requirements. See your machine's manual for these instructions.

- Keep all step plates, grab bars, pedals, and controls free of dirt, grease, debris, and oil.
- Never allow anyone to be around the equipment when it is operating.
- Do not allow riders on the attachment or the tractor.
- Do not operate the equipment from anywhere other than the correct operators position.
- Never leave equipment unattended with the engine running or with this attachment in a raised position.
- Do not alter or remove any safety feature from the tractor or this attachment.
- Know your work site safety rules as well as traffic rules and flow. When in doubt on any safety issue, contact your supervisor or safety coordinator for an explanation.

EQUIPMENT SAFETY PRECAUTIONS

WARNING!



KNOW WHERE UTILITIES ARE

Observe overhead electrical and other utility lines. Be sure equipment will clear them. When digging, call your local utilities for location of buried utility lines, gas, water, and sewer, as well as any other hazard you may encounter.

WARNING!



EXPOSURE TO RESPIRABLE CRYSTALLINE SILICA DUST ALONG WITH OTHER HAZARDOUS DUSTS MAY CAUSE SERIOUS OR FATAL RESPIRATORY DISEASE.

It is recommended to use dust suppression, dust collection and if necessary personal protective equipment during the operation of any attachment that may cause high levels of dust.

WARNING!



REMOVE PAINT BEFORE WELDING OR HEATING

Hazardous fumes/dust can be generated when paint is heated by welding, soldering or using a torch. Do all work outside or in a well ventilated area and dispose of paint and solvent properly. Remove paint before welding or heating.

When sanding or grinding paint, avoid breathing the dust. Wear an approved respirator. If you use solvent or paint stripper, remove stripper with soap and water before welding. Remove solvent or paint stripper containers and other flammable material from area. Allow fumes to disperse at least 15 minutes before welding or heating.

WARNING!



END OF LIFE DISPOSAL

At the completion of the useful life of the unit, drain all fluids and dismantle by separating the different materials (rubber, steel, plastic, etc.). Follow all federal, state and local regulations for recycling and disposal of the fluid and components.



OPERATING THE ATTACHMENT

- Never use your attachment for a work platform or personnel carrier.
- Operate only from the operator's station.
- Do not lift loads in excess of the capacity of the prime mover or attachment.
- When operating on slopes, drive up and down, not across. Avoid steep hillside operation, which could cause the prime mover to overturn.
- Reduce speed when driving over rough terrain, on a slope or turning, to avoid overturning the prime mover.
- Never heap load heavy material where the combined weight of the attachment and material could exceed the rated lifting capacity of the loader.
- Be sure the load does not stick out too far in front of the attachment. A light load sticking out too far can have the same tipping effect as a heavy load carried in close.
- When using the grapple, lift the load slightly and make sure that the load is secure. If the load appears to be unstable, lower the load, open the grapple and reposition the load to attain full stability.
- An operator must not use drugs or alcohol, which can change his or her alertness or coordination. An operator taking prescription or over-the-counter drugs should seek medical advice on whether or not he or she can safely operate equipment.
- Before exiting the prime mover, lower the attachment to the ground, turn off the prime mover's engine, remove the key and apply the brakes.

EQUIPMENT SAFETY PRECAUTIONS



TRANSPORTING THE ATTACHMENT

- When driving on public roads use safety lights, reflectors, Slow Moving Vehicle signs etc., to prevent accidents. Check local government regulations that may affect you.
- Do not drive close to ditches, excavations, etc., cave in could result.
- Do not smoke when refueling the prime mover. Allow room in the fuel tank for expansion. Wipe up any spilled fuel. Secure cap tightly when done.



MAINTAINING THE BACKHOE

- Before performing maintenance, lower the attachment to the ground, turn off the engine, remove the key and apply the brakes.
- Never perform any work on the attachment unless you are authorized and qualified to do so. Always read the operator service manuals before any repair is made. After completing maintenance or repair, check for correct functioning of the backhoe. If not functioning properly, always tag “DO NOT OPERATE” until all problems are corrected.
- Worn, damaged, or illegible safety decals must be replaced. New safety decals can be ordered from Paladin.
- Never make hydraulic repairs while the system is under pressure, or cylinders under load. Serious personal injury or death could result.
- Never work under a raised attachment.

DECALS

GENERAL INFORMATION

The diagram on this page shows the location of the decals used on your attachment. The decals are identified by their part numbers, with reductions of the actual decals located on the following page. Use this information to order replacements for lost or damaged decals. Be sure to read all decals before operating the attachment. They contain information you need to know for attachment safety.

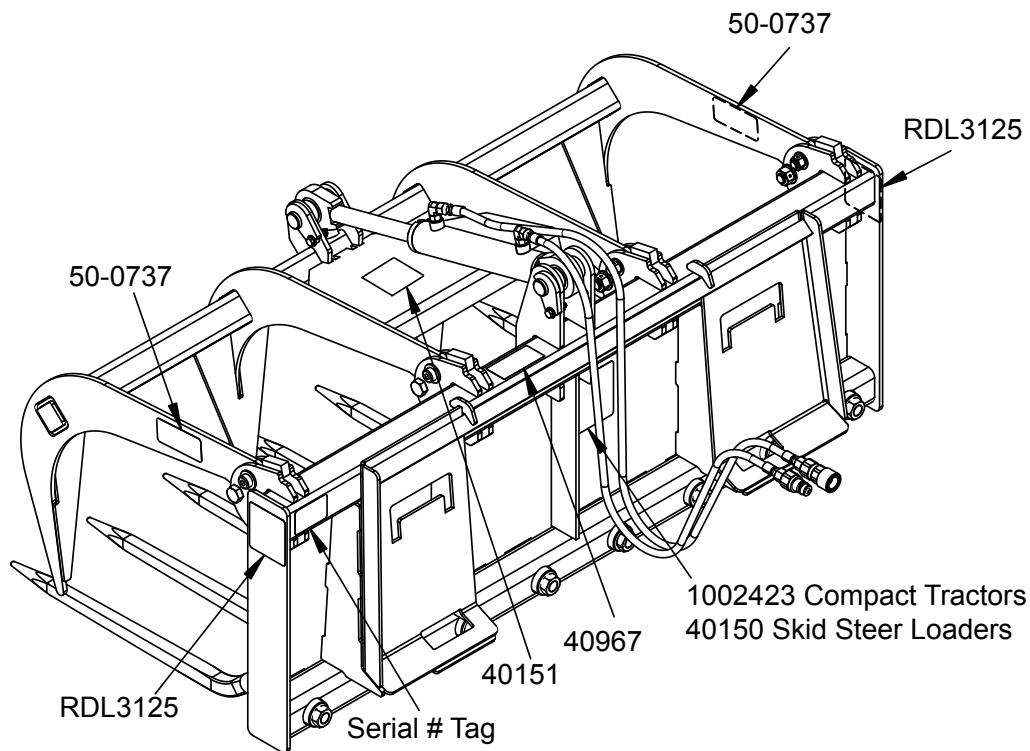

IMPORTANT: Keep all safety decals clean and legible. Replace all missing, illegible, or damaged safety decals. When replacing parts with safety decals attached, the safety decals must also be replaced. Safety decals are available, free of charge, from your local dealer or Paladin.

REPLACING SAFETY DECALS: Clean the area of application with nonflammable solvent, then wash the same area with soap and water. Allow the surface to fully dry. Remove the backing from the safety decal, exposing the adhesive surface. Apply the safety decal to the position shown in the diagram above and smooth out any bubbles.

DECALS



PART # 1002423
WARNING! READ MANUAL
(COMPACT TRACTOR ONLY)



PART # 40151
WARNING! HIGH PRESSURE FLUID



PART # 40967
WARNING! SPECIFICATIONS
(COMPACT TRACTOR ONLY)

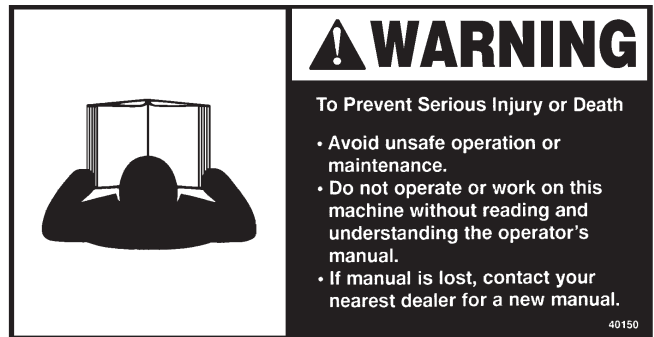

PART # 1002423
WARNING! READ MANUAL
(SKID STEER LOADER ONLY)



PART # 50-0737
WARNING! PINCH POINT HAZARD



PART # RDL3125
WARNING! CRUSH HAZARD

INSTALLATION

The following instructions will help you to mount your attachment onto your prime mover. The *attachment* uses the quick-attach system for ease of installation. Therefore, if you know how to attach your loader bucket, attaching the *attachment* should prove no problem.

Remember to read all safety warnings, decals and operating instructions before operating the attachment. If there is any portion of this manual that you do not understand, contact your dealer.

ATTACHING

Remove any attachment from the front of the loader. Following all standard safety practices and the instructions for installing an attachment in your prime mover operator's manual, install the attachment onto your loader.

WARNING! To Avoid Serious Personal Injury, make sure the Manure Fork is securely latched to the attachment mechanism of your unit. Failure to do so could result in separation of the attachment from the unit.



Connect the hydraulic quick couplers to the auxiliary hydraulics and route the hoses in such a fashion as to prevent chafing and pinching.

Start engine and slowly cycle the cylinder several times to purge any air from the system. Check for proper hydraulic connections, hose routing and hose length. Carefully raise the loader and cycle the tilt cylinders to check clearances and to verify that all mounting procedures have been successfully completed.

Check the attachment for hydraulic leaks.

DETACHING

On firm level ground, close the arms and lower the attachment to the ground. Turn off the engine and move control levers back and forth to relieve pressure in the hydraulic lines. Disconnect couplers.

NOTE: Connect couplers together or install caps to prevent contaminants from entering the hydraulic system.

Follow your prime mover operator's manual for detaching (removing) an attachment.

NOTE: Frequent lubrication of grease fittings at the ends of the cylinder and the pivot points with a multi-purpose grease will greatly increase life of the product.

OPERATION

**Read all Safety Precautions before operating your new attachment.
Refer to your machines operator's manual for attachment operation.**

INTENDED USE: The manure fork grapple was designed for moving loose hay, manure, brush and small branches.

1. Depending on the material being moved, approach so the fork tines are either centered under the load (brush or branches) or "stabbing" into the load (pile of hay or manure).
2. Close the grapples to their fullest extent possible and lift the attachment slightly to be certain that the load is secure.

NOTE: If the load appears to be unstable, lower the forks to the ground, open the grapples and reposition the load to attain full stability. Repeat until full stability is achieved.

When using the grapples as a rake to drag materials into position for pick up, THE GRAPPLES MUST BE COMPLETELY OPEN.

NOTICE *Applying a raking-type force to partially open grapples will greatly magnify the fluid pressure in the hydraulic hoses, fittings, and cylinders and may cause component failure.*

Never heap load heavy material where the combined weight of the attachment and material could exceed the rated lifting capacity of the loader.

Be sure the load does not stick out too far in front of the bucket. A light load sticking out too far can have the same tipping effect as a heavy load carried in close.

Operate the attachment only when properly seated at the operator's station.

Do not exceed the lift capacity of your loader. See loader specifications.

Do not handle round bales.

When using the grapple, lift the load slightly and make sure that the load is secure. If the load appears to be unstable, lower the load, open the grapple and reposition the load to attain full stability.

Reduce speed when driving over rough terrain, on a slope, or turning, to avoid overturning the vehicle.

Avoid side slope travel whenever possible. Drive up the slope to pick up a load and then down in reverse. Carry loads as close to the ground as possible.

Before exiting the prime mover, lower the bucket to the ground, turn off the prime mover's engine, remove the key and apply the brakes.

Do not detach loader from tractor with this attachment installed. Equip loader with materials bucket when detaching.

OPERATION

STORAGE:

- Clean the unit thoroughly, removing all mud, dirt, and grease.
- Inspect for visible signs of wear, breakage, or damage. Order any parts required and make the necessary repairs to avoid delays upon removal from storage.
- Tighten loose nuts, capscrews and hydraulic connections.
- Coat exposed portions of the cylinder rods with grease.
- Lubricate grease fittings.
- Seal hydraulic system from contaminants and secure all hydraulic hoses off the ground to help prevent damage.
- Replace decals that are damaged or in unreadable condition.
- Store unit in a dry and protected place. Leaving the unit outside will materially shorten its life.

Additional Precautions for Long term Storage:

- Touch up all unpainted surfaces with paint to prevent rust.

REMOVAL FROM STORAGE:

- Remove cover.
- Wash unit and replace any damaged and/or missing parts.
- Lubricate grease fittings.
- Check hydraulic hoses for damage and replace as necessary.

LIFT POINTS

Lifting points are identified by lifting decals where required. Lifting at other points is unsafe and can damage attachment. Do not attach lifting accessories around cylinders or in any way that may damage hoses or hydraulic components. See Diagram

- Attach lifting accessories to unit at recommended lifting points.
- Bring lifting accessories together to a central lifting point.
- Lift gradually, maintaining the equilibrium of the unit.

WARNING! Use lifting accessories (chains, slings, ropes, shackles and etc.) that are capable of supporting the size and weight of your attachment. Secure all lifting accessories in such a way to prevent unintended disengagement. Failure to do so could result in the attachment falling and causing serious personal injury or death.



TIE DOWN POINTS

Tiedown points are identified by tiedown decals where required. Securing to trailer at other points is unsafe and can damage attachment. Do not attach tie down accessories around cylinders or in any way that may damage hoses or hydraulic components. See Diagram.

- Attach tie down accessories to unit as recommended.
- Check unit stability before transporting.

WARNING! Verify that all tiedown accessories (chains, slings, ropes, shackles and etc.) are capable of maintaining attachment stability during transporting and are attached in such a way to prevent unintended disengagement or shifting of the unit. Failure to do so could result in serious personal injury or death.



MAINTENANCE

GENERAL INFORMATION

Your attachment was designed to be virtually maintenance free. Very little effort is needed to keep it in top condition. It is, however, important to follow these procedures to get full performance and longevity out of the equipment.

IMPORTANT: When replacing parts, use only factory approved replacement parts. Manufacturer will not claim responsibility for use of unapproved parts or accessories and/or other damages as a result of their use.

Procedure	Daily	Every 40 Hours
Hardware - Check for tightness (see Bolt Torque Specifications)	✓	
Replace any missing bolts or nuts with approved replacement parts.	✓	
Hydraulic System - Check for leaks and tighten as necessary. Check for damage and replace as needed.	✓	
Lubricate grease fittings. (After first 8 hours of operation and then every 40 hours of operation thereafter.)		✓
Decals - Check for missing or damaged safety decals and replace as necessary.	✓	
Inspect attachment for any worn parts or cracked welds. Repair as required.	✓	

WARNING! DO NOT MODIFY MACHINE OR ATTACHMENTS



Modifications may weaken the integrity of attachment and may impair the function, safety, life and performance of the attachment.

SPECIFICATIONS

ATTACHMENT SPECIFICATIONS

Model Number	Overall Width	Overall Height	Overall Depth	Grapple Opening	Shipping Weight
10708-60	60"	25"	30"	37"	450#
10708-72	72"	25"	30"	37"	475#
10708-84	84"	25"	30"	37"	525#
10708-96	96"	25"	30"	37"	600#
10718-60	60"	25"	30"	n/a	250#
10718-72	72"	25"	30"	n/a	275#
10718-84	84"	25"	30"	n/a	325#
10728	58.5"	19"	30"	n/a	200#

COMPACT TRACTOR LIMITATIONS

IMPORTANT Exceeding any of the maximum recommended tractor/loader specifications **CAN** result in damage to this product and **WILL** void all FFC warranties.

DESCRIPTION	SPECIFICATIONS
Tractor HP	40 HP maximum
Operating Weight of Tractor	4,000 lbs. maximum
Lift Capacity of Tractor's Loader	2,000 lbs. maximum
Rear Ballast	As required to maintain full tractor stability. (Note the shipping weight of your model, then see the operator's manual(s) for your tractor and loader for ballasting needs.)

BOLT TORQUE



BOLT TORQUE SPECIFICATIONS

GENERAL TORQUE SPECIFICATION TABLES

Use the following charts when determining bolt torque specifications when special torques are not given. Always use grade 5 or better when replacing bolts.



SAE BOLT TORQUE SPECIFICATIONS

NOTE: The following torque values are for use with extreme pressure lubricants, plating or hard washer applications. Increase torque 15% when using hardware that is unplated and either dry or lubricated with engine oil.

Bolt Size		SAE GRADE 5 TORQUE				SAE GRADE 8 TORQUE				Bolt head identification marks as per grade. NOTE: Manufacturing Marks Will Vary
		Pounds Feet		Newton-Meters		Pounds Feet		Newton-Meters		
Inches	Millimeters	UNC	UNF	UNC	UNF	UNC	UNF	UNC	UNF	
1/4	6.35	8	9	11	12	10	13	14	18	<div style="text-align: center;"> <p>GRADE 2</p>  <p>GRADE 5</p>  <p>GRADE 8</p>  </div>
5/16	7.94	14	19	19	23	20	25	27	34	
3/8	9.53	30	36	41	49	38	46	52	62	
7/16	11.11	46	54	62	73	60	71	81	96	
1/2	12.70	68	82	92	111	94	112	127	152	
9/16	14.29	94	112	127	152	136	163	184	221	
5/8	15.88	128	153	174	207	187	224	254	304	
3/4	19.05	230	275	312	373	323	395	438	536	
7/8	22.23	340	408	461	553	510	612	691	830	
1	25.40	493	592	668	803	765	918	1037	1245	
1-1/8	25.58	680	748	922	1014	1088	1224	1475	1660	
1-1/4	31.75	952	1054	1291	1429	1547	1700	2097	2305	
1-3/8	34.93	1241	1428	1683	1936	2023	2312	2743	3135	
1-1/2	38.10	1649	1870	2236	2535	2686	3026	3642	4103	

METRIC BOLT TORQUE SPECIFICATIONS

NOTE: The following torque values are for use with metric hardware that is unplated and either dry or lubricated with engine oil. Reduce torque 15% when using hardware that has extreme pressure lubricants, plating or hard washer applications.

Bolt head identification marks as per grade.		
		

Size of Bolt	Grade No.	Pitch (mm)	Pounds Feet	Newton-Meters	Pitch (mm)	Pounds Feet	Newton-Meters
M6	5.6	1.0	3.6-5.8	4.9-7.9	-	-	-
	8.8		5.8-4	7.9-12.7		-	-
	10.9		7.2-10	9.8-13.6		-	-
M8	5.6	1.25	7.2-14	9.8-19	1.0	12-17	16.3-23
	8.8		17-22	23-29.8		19-27	25.7-36.6
	10.9		20-26	27.1-35.2		22-31	29.8-42
M10	5.6	1.5	20-25	27.1-33.9	1.25	20-29	27.1-39.3
	8.8		34-40	46.1-54.2		35-47	47.4-63.7
	10.9		38-46	51.5-62.3		40-52	54.2-70.5
M12	5.6	1.75	28-34	37.9-46.1	1.25	31-41	42-55.6
	8.8		51-59	69.1-79.9		56-68	75.9-92.1
	10.9		57-66	77.2-89.4		62-75	84-101.6
M14	5.6	2.0	49-56	66.4-75.9	1.5	52-64	70.5-86.7
	8.8		81-93	109.8-126		90-106	122-143.6
	10.9		96-109	130.1-147.7		107-124	145-168
M16	5.6	2.0	67-77	90.8-104.3	1.5	69-83	93.5-112.5
	8.8		116-130	157.2-176.2		120-138	162.6-187
	10.9		129-145	174.8-196.5		140-158	189.7-214.1
M18	5.6	2.0	88-100	119.2-136	1.5	100-117	136-158.5
	8.8		150-168	203.3-227.6		177-199	239.8-269.6
	10.9		175-194	237.1-262.9		202-231	273.7-313
M20	5.6	2.5	108-130	146.3-176.2	1.5	132-150	178.9-203.3
	8.8		186-205	252-277.8		206-242	279.1-327.9
	10.9		213-249	288.6-337.4		246-289	333.3-391.6

Limited Warranty

Except for the Excluded Products as described below, all new products are warranted to be free from defects in material and/or workmanship during the Warranty Period, in accordance with and subject to the terms and conditions of this Limited Warranty.

1. Excluded Products. The following products are excluded from this Limited Warranty:

(a) Any cable, part that engages with the ground (i.e. sprockets), digging chain, bearing, teeth, tamping and/or demolition head, blade cutting edge, pilot bit, auger teeth and broom brush that either constitutes or is part of a product.

(b) Any product, merchandise or component that, in the opinion of Paladin Light Construction¹, has been (i) misused; (ii) modified in any unauthorized manner; (iii) altered; (iv) damaged; (v) involved in an accident; or (vi) repaired using parts not obtained through Paladin Light Construction.

2. Warranty Period. The Limited Warranty is provided only to those defects that occur during the Warranty Period, which is the period that begins on the first to occur of: (i) the date of initial purchase by an end-user, (ii) the date the product is first leased or rented, or (iii) the date that is six (6) months after the date of shipment by Paladin Light Construction as evidenced by the invoiced shipment date (the "Commencement Date") and ends on the date that is twelve (12) months after the Commencement Date.

3. Terms and Conditions of Limited Warranty. The following terms and conditions apply to the Limited Warranty hereby provided:

(a) Option to Repair or Replace. Paladin Light Construction shall have the option to repair or replace the product.

(b) Timely Repair and Notice. In order to obtain the Limited Warranty, (i) the product must be repaired within thirty (30) days from the date of failure, and (ii) a claim under the warranty must be submitted to Paladin Light Construction in writing within thirty (30) days from the date of repair.

(c) Return of Defective Part or Product. If requested by Paladin Light Construction, the alleged defective part or product shall be shipped to Paladin Light Construction at its manufacturing facility or other location specified by Paladin Light Construction, with freight PRE-PAID by the claimant, to allow Paladin Light Construction to inspect the part or product.

Claims that fail to comply with any of the above terms and conditions shall be denied.

LIMITATIONS AND EXCLUSIONS.

THIS LIMITED WARRANTY IS IN LIEU OF ALL OTHER WARRANTIES, EXPRESS OR IMPLIED, INCLUDING WITHOUT LIMITATION THE WARRANTIES OF MERCHANTABILITY, FITNESS FOR A PARTICULAR PURPOSE AND ANY WARRANTY BASED ON A COURSE OF DEALING OR USAGE OF TRADE.

IN NO EVENT SHALL PALADIN LIGHT CONSTRUCTION BE LIABLE FOR CONSEQUENTIAL OR SPECIAL DAMAGES.

IN NO EVENT SHALL PALADIN LIGHT CONSTRUCTION BE LIABLE FOR ANY LOSS OR CLAIM IN AN AMOUNT IN EXCESS OF THE PURCHASE PRICE, OR, AT THE OPTION OF PALADIN LIGHT CONSTRUCTION, THE REPAIR OR REPLACEMENT, OF THE PARTICULAR PRODUCT ON WHICH ANY CLAIM OF LOSS OR DAMAGE IS BASED. THIS LIMITATION OF LIABILITY APPLIES IRRESPECTIVE OF WHETHER THE CLAIM IS BASED ON BREACH OF CONTRACT, BREACH OF WARRANTY, NEGLIGENCE OR OTHER CAUSE AND WHETHER THE ALLEGED DEFECT IS DISCOVERABLE OR LATENT.

¹Attachment Technologies Inc., a subsidiary of Paladin Brands Holding, Inc. (PBHI) is referred to herein as Paladin Light Construction.

MANURE FORK GRAPPLE

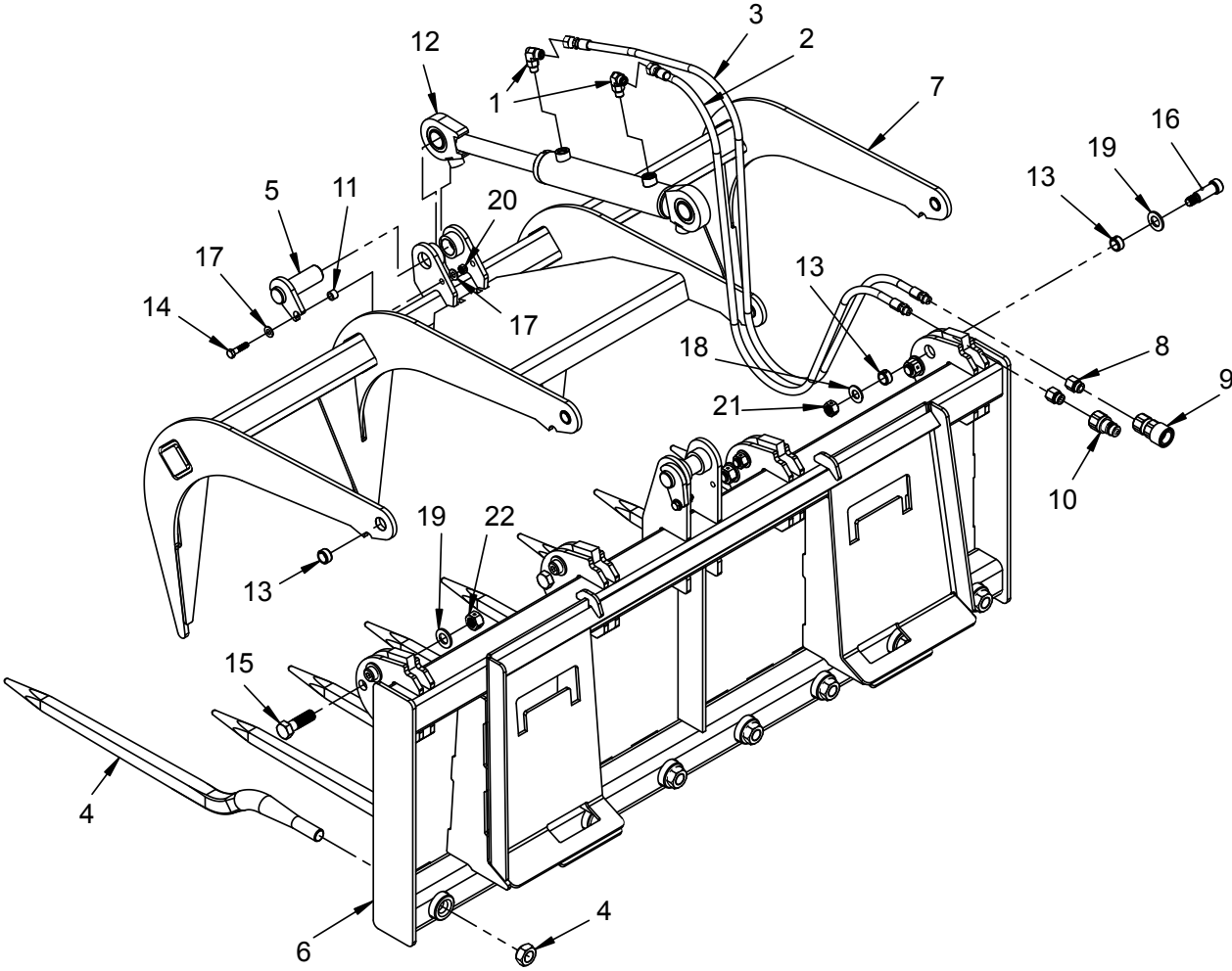

MANURE FORK GRAPPLE

ITEM	QTY.	10708-60	10708-72	10708-84	10708-96	DESCRIPTION
1	2				30204	90° Elbow 6MB-6MF
2	1				03-10124	Hose .25 x 72" 6FF-6MB Sheathed
3	1				03-10125	Hose .25 x 81" 6FF-6MB Sheathed
4	varies	(8)	(9)	(10)	(12) 07-10157	Tine Cranked Conus I w/ M24 Nut
5	2				13-52369	Pivot Pin Weldment 3.47"
6	1	13-52550	13-52551	13-52552	13-52553	Main Frame Weldment
7	1				13-52577	Grapple Weldment
*8	2				3338	Adaptor 6FB-8MB
*9	1				17139	QD Male 8FBO PP .50 BODY
*10	1				17140	QD Female 8FBO PP .50 BODY
11	2				81595	Tube Rnd .62 x .385 x .44 YDC
12	1				107865	Hydraulic Cylinder 2 x 8.5 x 1.25 3000psi
13	12				LAF9481	Connex Spring Bushing 1.00 OD X 0.75 ID X 0.50 No Holes or Grooves
14	2				1045	Grade 5 Hex Head Cap Screw .38" x 1.5"
15	4				1141	Grade 5 Hex Head Cap Screw .75" x 2.5"
16	4				10016	Allen Head Shoulder Screw: .75" x 1.75" (.63" dia.x .88" threads)
17	4				1800	Hard Flat Washer .38"
18	4				1627	Hard Flat Washer .63"
19	8				1649	Hard Flat Washer .75"
20	2				1837	Grade 5 Center Dent Lock Nut .38"
21	4				1839	Grade 5 Center Dent Lock Nut .63"
22	4				1936	Grade 5 Center Dent Lock Nut .75"

NOTE: All parts are the same as 10708-96 except for those parts numbered under the other models.

*ITEM may vary per tractor/loader -- Contact FFC for correct item.

10718 Manure Fork Only: Items 4 and 6.

10728 Grapple Kit Only: All items except 4 and 6.

