

Talet Equipment International Ltd.

Auger Bucket

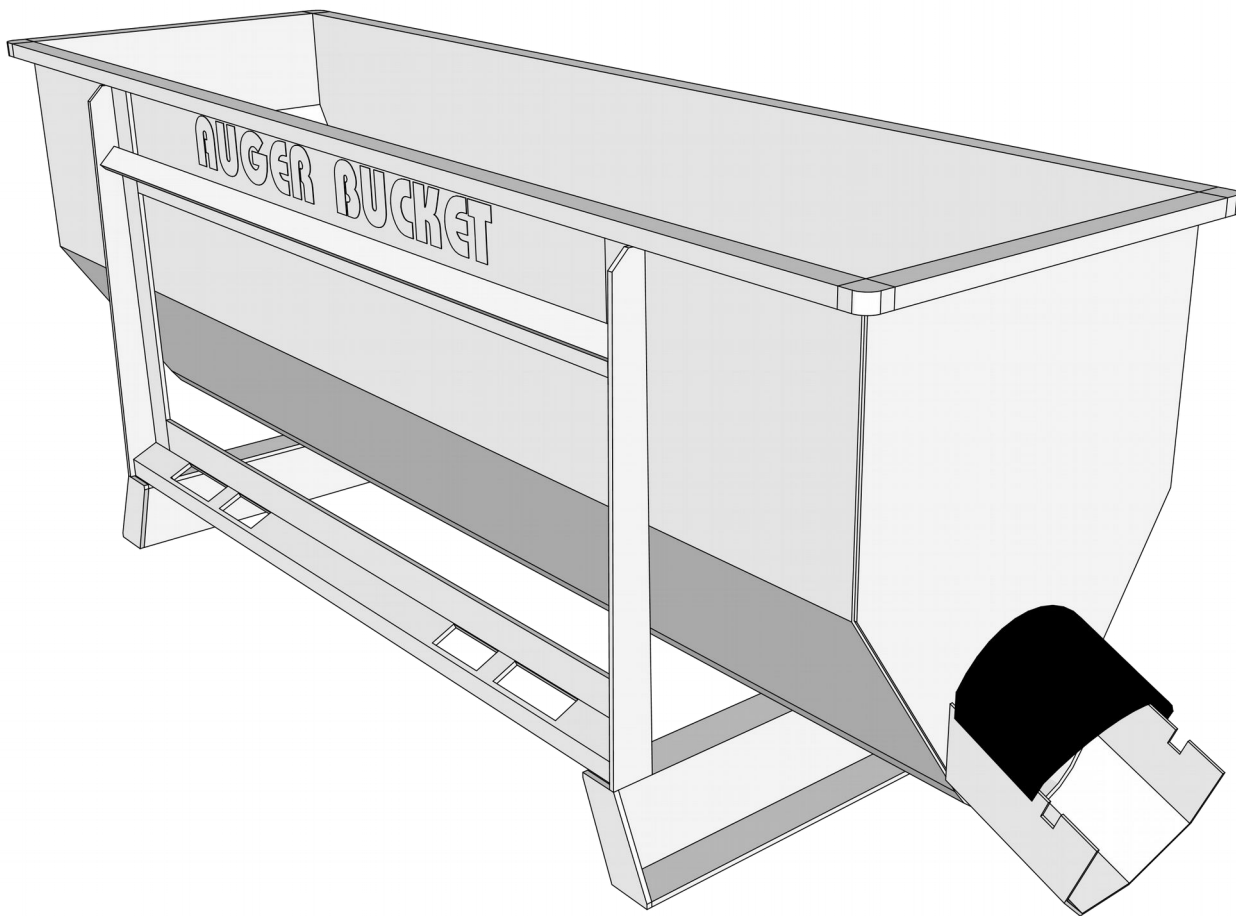

Parts & Operators Manual

P.O. Box 2351
Strathmore AB
Canada
T1P 1K3

www.taletattachments.com
sales@taletattachments.com
Toll Free 1-888-317-5878
Fax 1-403-934-3042

To The Owner

General Comments

Congratulations on the purchase of your new Talet Auger Bucket. Your unit was carefully designed and manufactured to give you many years of dependable service. Your Auger Bucket will require some minor maintenance to keep it in top working condition. Be sure to observe all maintenance procedures and safety precautions in this manual and the safety decals located on the bucket and on any equipment on which it is mounted.

About This Manual

Read this manual before using your bucket. This manual has been designed to help you do a better and safer job. Read this manual carefully and become familiar with the operating procedures before attempting to operate your auger bucket. Remember, never let anyone operate this unit without them having read and completely understanding the “Safety Precautions” and “Operating Instructions” section of the manual, or having them be fully trained by an experienced, qualified person who has read and completely understands the “Safety Precautions” and “Operating Instructions”.

Service

When servicing your Auger Bucket remember to use only original manufacturer replacement parts. Substitute parts may not meet the standards required for safe, dependable operation.

To facilitate parts ordering, record the model and serial number in the space provided on the page. This information may be obtained from the identification plate located on your bucket.

Model _____ Serial No. _____

Your parts department needs this information to insure that you receive the correct parts for your specific model of auger bucket.

Safety Precautions

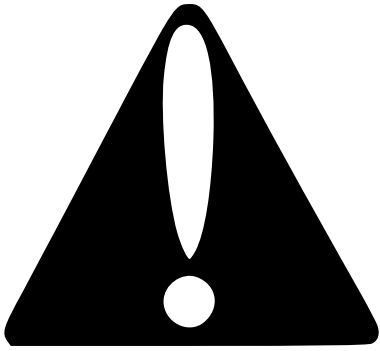

Safety Alert Symbol

This is the “Safety Alert Symbol” used by this industry. This symbol is used to warn of possible injury. Be sure to read all warnings carefully. They are included for your safety and for the safety of others working around you.

Signal Words

Note the use of signal words Danger, Warning, and Caution with the safety messages. The appropriate signal word for reach has been selected using the following guidelines:

- **DANGER:** Indicates an immediate hazardous situation in which, if not avoided, will result in death or serious injury. This signal word is to be limited to the most extreme situations; typically for machine components which, for functional purposes, cannot be guarded.
- **WARNING:** Indicated a potentially hazardous situation in which, if not avoided, can result in death or serious injury and indicated hazards that exposed when guards are removed. It may also be used to alert against unsafe practices.
- **CAUTION:** Indicates a potentially hazardous situation which, if not avoided, may result in minor or moderate injury. It may also be used to alert against unsafe practices.

Safety Rules

To insure skid steer stability, and to prevent tipping, always observe the following safety rules:

- Keep clear of unit while in operation.
- Before operating the skid steer, read the operating and safety instructions provided by the manufacturer. Observe all warnings and caution particularly those which describe the use of seat belts and other operator restraints and those which describe the proper way of carrying loads as close to the ground as possible.

Safety Precautions

- When using the Auger Bucket be sure that the proper weight of the load is not too heavy. A light load sticking out too far can have the same tipping effect on the loader as a heavy load carried too close.
- Never operate the Postmaster when people are standing by the unit and could be injured.
- Do not obstruct your vision when traveling or working. Carry the Postmaster low for maximum stability and visibility when traveling.
- Operate at speeds slow enough so that you have complete control at all times. Travel slowly over rough or slippery ground and on hillsides.
- Avoid steep slopes or unstable surfaces. If you must drive on a slope, keep the load low and proceed with extreme caution. Do not drive across a steep slope under any circumstances. Drive straight up and down the slope.
- Avoid turning on an incline, if at all possible. If it is necessary, use extreme caution and make the turn wide and slow with the bucket carried low.



If you can't see where you are going then stop.

Skid-steer Loader Safety

1. Read the entire skid-steer loader operators manual before ever attempting to use the skid steer loader. This knowledge is necessary for safe operation.
2. Follow all safety decals on the skid-steer loader. Keep them clean and replace them if they become worn and hard to read.
3. Know the limitation of your equipment. Do not use equipment for anything other than what it was originally designed for.

Safety Precautions

4. Pay attention to the job at hand. Do not let your mind lose concentration on what you are doing.
5. Use your seat belt and R.O.P.S. (Roll Over Protective Structure) when operating the skid-steer loader. Keep belt and R.O.P.S. in good repair. Do not modify R.O.P.S. or seat belt. Do not remove R.O.P.S. or seat belt. Overturning the skid-steer loader without proper R.O.P.S. and seat belt can result in death.
6. Fasten your seat belt before and during skid steer loader operation. Remain seated at all times.
7. Do not take passengers on the skid steer loader or attachment. There is no safe place for a passenger.
8. Use hand hold when getting on and off the skid-steer loader. Failure to do so could cause a fall.
9. Inspect the skid steer loader before you try to operate the unit. Check for needed maintenance or repairs and have them done before using the equipment.
10. Never leave the skid steer loader running unattended. Always lower lift arms, set parking brake, turn off engine, and remove key.
11. Wear appropriate clothing such as safety glasses, ear plugs, etc. Do not wear loose fitting clothing; it may catch on the equipment. Always wear a hardhat when operating the skid-steer loader to prevent head injury.
12. When driving on public roads use safety light, reflectors, slow moving vehicle sign, etc., to prevent accidents. Check with local governments for regulations that may affect you.
13. Turn off the skid-steer loader before performing maintenance. If the lift arms must be left raised for any reason, use a positive lift arm lock to secure arms in place. Serious damage or personal injury could result from lift arms accidentally lowering.
14. Reduce speed when driving on rough terrain, slopes, or turning, to avoid overturning the skid-steer loader.

Safety Precautions

15. Do not smoke when refueling the skid-steer loader. Allow room in the gas tank for expansion. Wipe up any spilled liquid. Secure cap tightly when done.



Escaping fluid under pressure can have sufficient force to penetrate the skin causing serious personal injury. Fluid escaping from a very small hole can be almost invisible. Use a piece of cardboard or wood, rather than your hands, to search for suspected leaks.

Keep unprotected body parts, such as face, eyes, and arms, as far away as possible from a suspected leak. Flesh injected with hydraulic fluid may develop gangrene or other permanent disabilities. If injured by injected fluid, see a doctor at once. If your doctor is not familiar with this type of injury, ask him to research immediately to determine proper treatment.

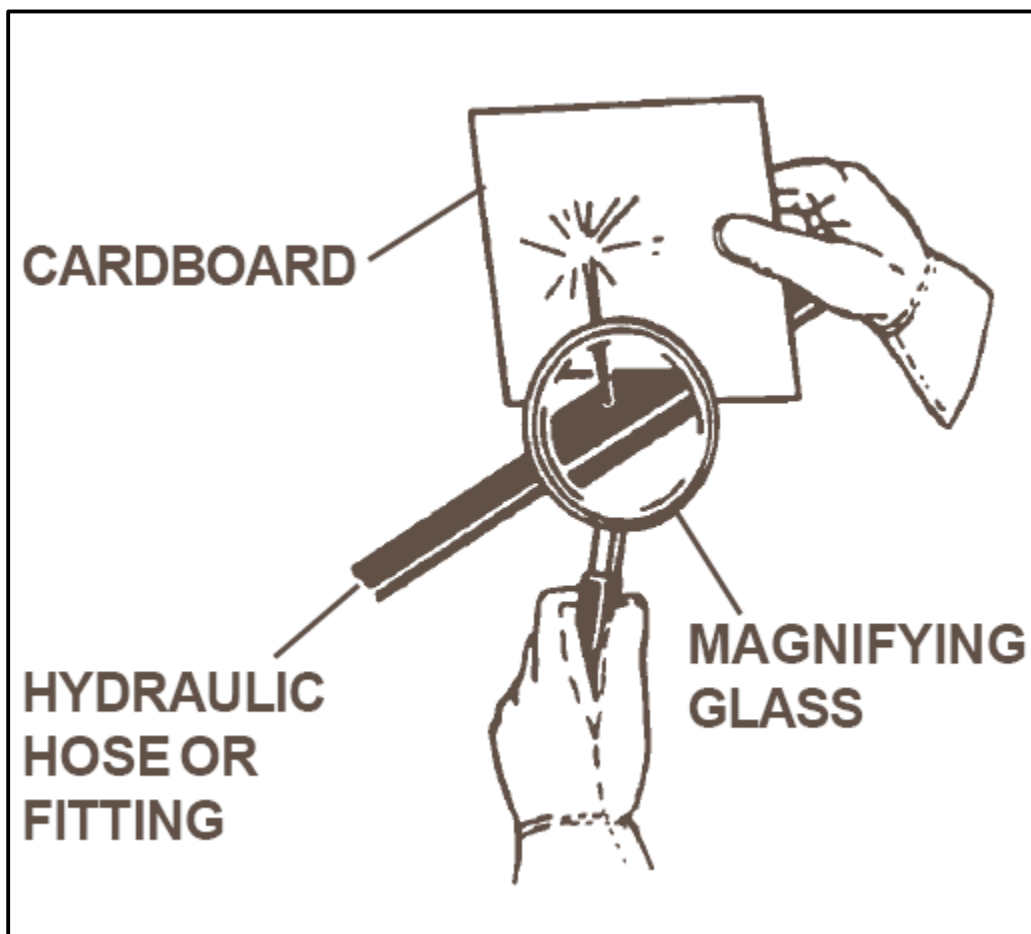

Pre-Operation

General Information

The purpose of this manual is to assist in setting up, operating, and maintaining your auger bucket. Parts lists and diagrams along with optional equipment available are located at the back of this manual. The illustration and data used in this manual were current at the time of printing, however, we reserve the right to redesign and change the auger buckets as may be necessary without notification.

Preparing the Vehicle

Your skid-steer must be equipped with a universal quick-tach hitch and auxiliary hydraulics. read your skid-steer loader operator's manual and know the limitations of your skid-steer loader, it may require the addition of a counterweight kit to ensure that the combined weight of the bucket and the material does not exceed the rated capacity of your loader.

Note: An easy formula for calculating weight:

- 1/2 yard bucket and material - empty bucket weight + 2000 lbs.
- 3/4 yard bucket and material - empty bucket weight + 3000 lbs.

Selecting the Right Auger for the Job

Mixing Auger

The mixing auger should be used anytime you are mixing your own material. This auger has the wear rubber reversed for the first half of the auger (motor end) and then regular for the discharge end. This auger also has 40% more hardware than a discharge auger for added durability.

Discharge Auger

The discharge auger should be used for the discharge of most materials such as: sand, concrete (0" - 5" Slump) with 3/4" rocks, pea gravel, and rock up to 3/8". This auger has the wear rubber on one side (discharge side) of the belting on the rubber flights.

Pre-Operation



Do not use the discharge auger for mixing. Running this auger in the reverse direction (mixing) will result in extreme premature wear of the rubber flighting.

Steel Auger

The steel auger should be used on asphalt and any dry mixtures or materials.

Auger Bucket Assembly

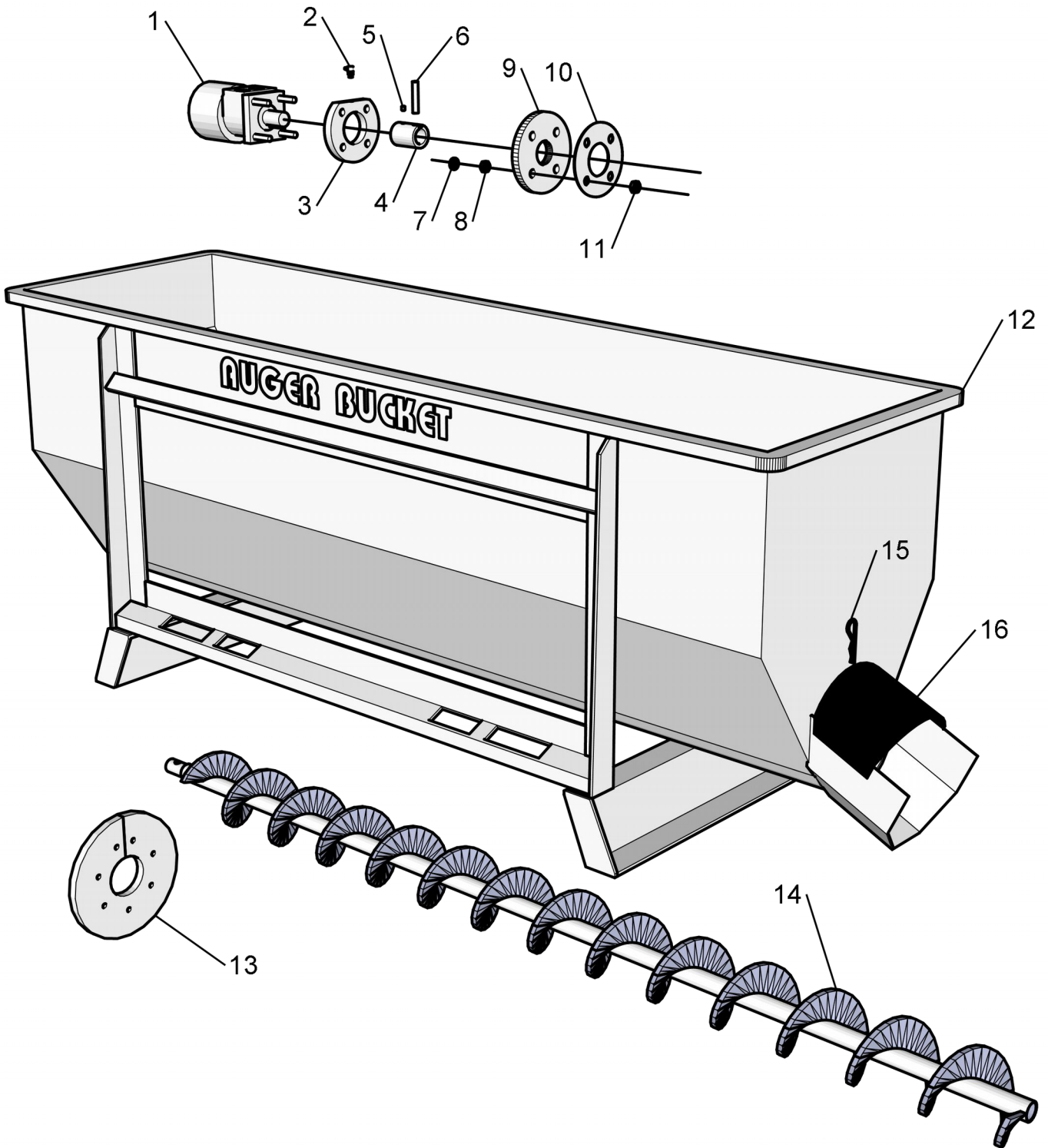

Auger Bucket Assembly

No.	Req'd	Part No.	Description
1	1	90172	Standard Motor
		87507	Heavy Service Motor
		87551	Replacement Key
2	1	53031	90° Grease Zerk
3	1	87510	Motor Mounting Plate - Standard
		90023	Motor Mounting Plate – Heavy Service
4	1	90011	Hub
5	1	90010	.31" x .38" Set Screw
6	1	87511	Roll Pin .38" x 2"
7	4	1503	.38" Lock Washer
8	4	1226	.38" UNC Hex Nut
9	1	90037	Motor Seal
10	1	87515	Seal Retainer
11	4	1229	.38" UNC Lock Nut
12	1	90177	Auger Bucket Frame
13	-	AFD01	Replacement Auger Fliting (Standard)
		AFM02	Replacement Auger Fliting (Mixing)
14	1	AD001	Discharge Auger Assembly
	1	AM002	Mixing Auger Assembly
	1	AS001	Steel Auger Assembly
15	1	1617	Hair Pin
16	1	87517	Splash Guard

Note: Items 4, 5, 6, 9, 11 Sold As Hub and Seal Kit (HS002)

Hydraulic Assembly

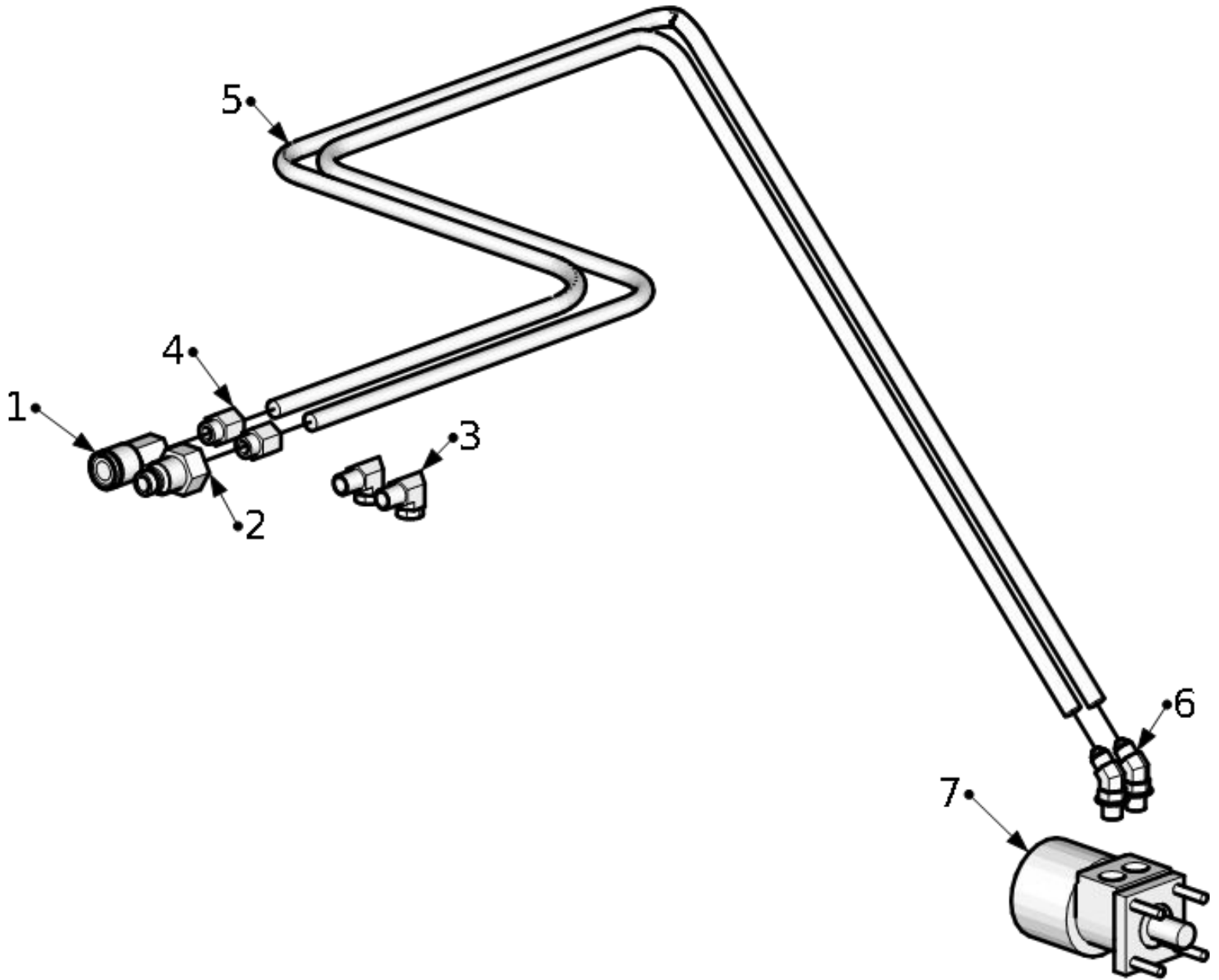

Hydraulic Assembly

No.	Req'd	Part No.	Description
1	1	80132	Flat Face Female Coupler (10 ORB)
2	1	80133	Flat Face Male Coupler (10 ORB)
3	2	90022	90° Adapter 10MB – 8FP
4	2	90284	Straight Adapter 10MB – 8FP
5	2	87554	Hose Assembly .50" x 84" 8MPX – 8FJ
6	2	90021	45° Adapter 10MB – 8MJ
7	1	90172	Standard Motor

Options

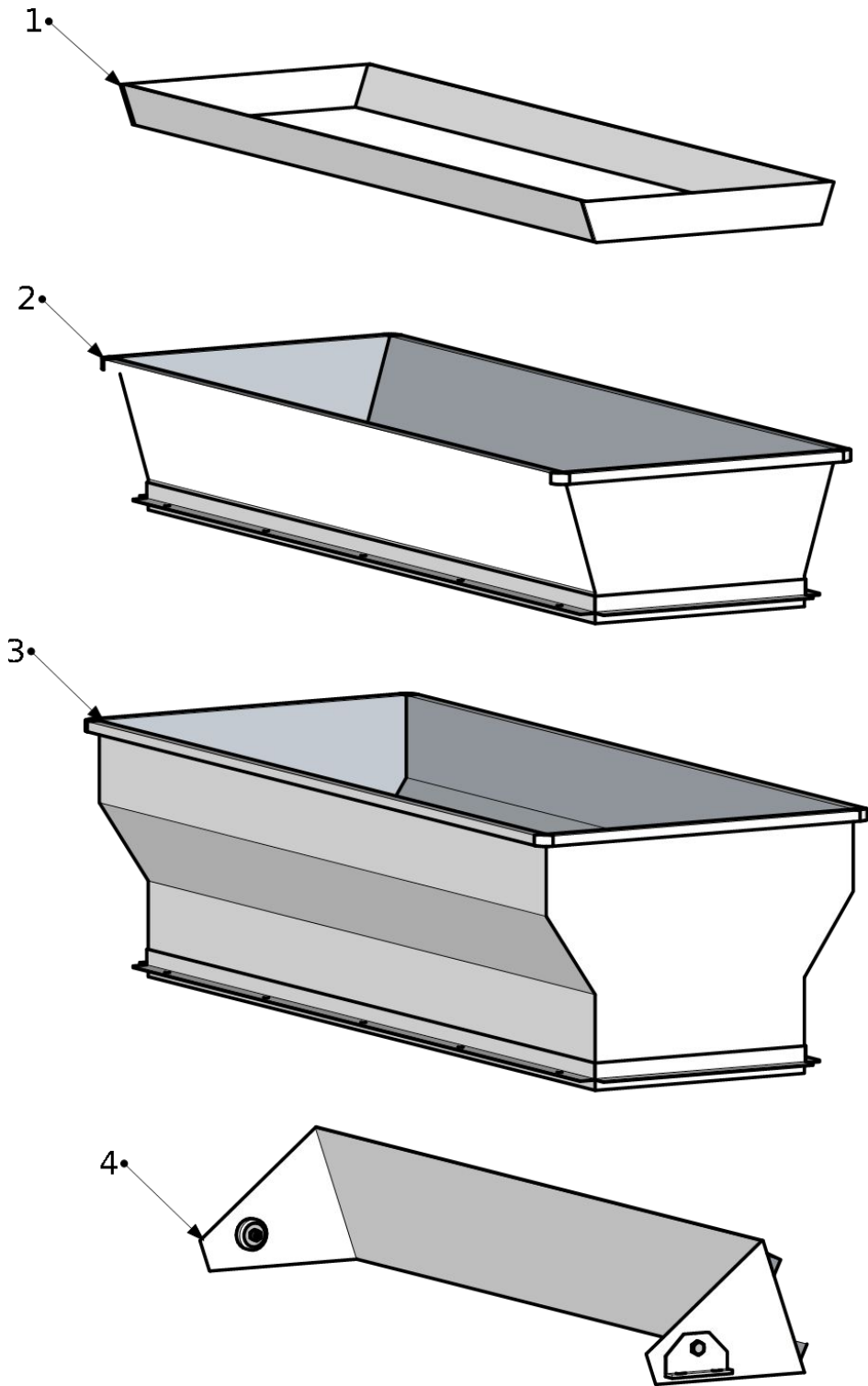

Options

No.	Req'd	Part No.	Description
1	-	87137	Scraper Blade (Welding Required for Field Installation)
2	-	87134	Three Quarter Yard Hopper Extension
3	-	87133	One Yard Hopper Extension
4	-	90001	Spill Guard (Not compatible with hopper extensions)

Options

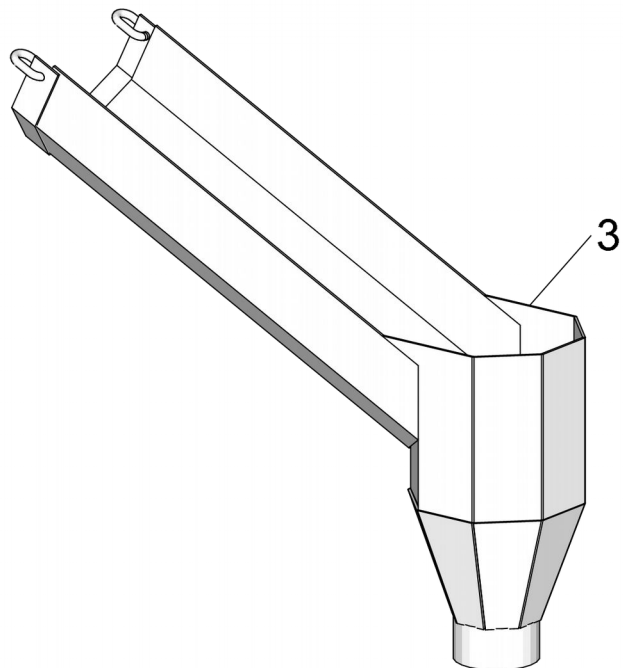
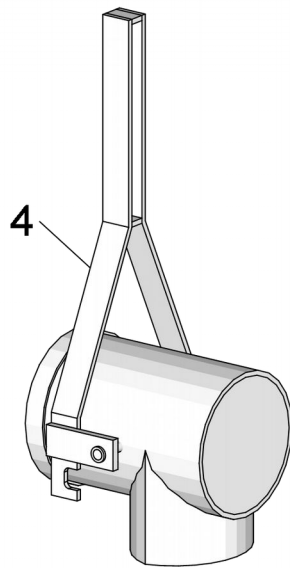
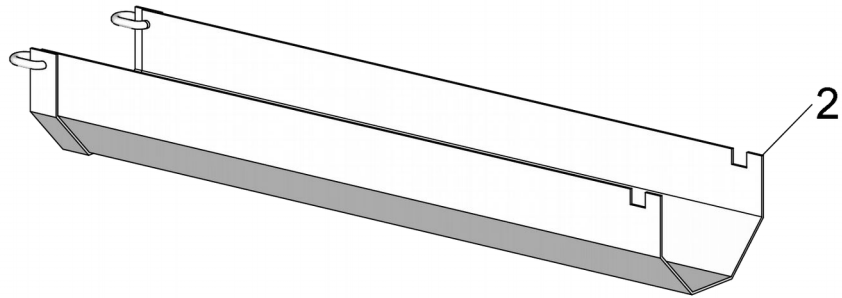
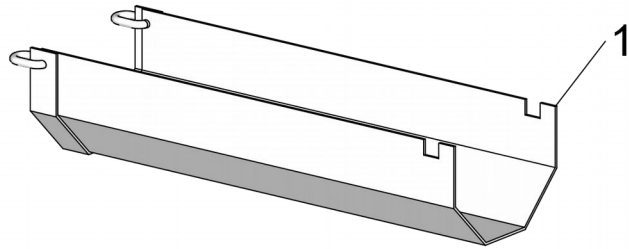
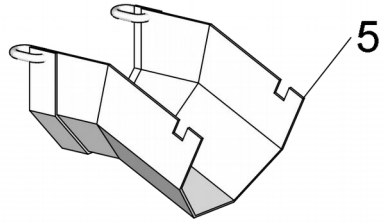

Options

No.	Req'd	Part No.	Description
1	-	87139	24" Chute
2	-	87140	36" Chute
3	-	87136	4" Hose Adapter
4	-	90224	6" Hose Adapter
5	-	87141	Angle Increaser

Mounting Instructions

Installation Instructions

After determining the rated capacity of your loader and adding any counterweight kits that are needed you are ready to install your bucket.

1. Remove the chutes and hydraulic hoses from inside of the auger bucket.
2. Remove dust plugs from the auger motor.
3. Locate the fittings from the chute box and install them into the motor. Do not allow dirt or contaminants to get into the hydraulic system (motor, hoses or fittings).
4. Tighten the fittings into the motor and install the hydraulic hoses provided.
5. Install the bucket by following your skid-steer operators manual for installing an attachment. Be sure to lock the bucket to the skid-steer.

Note: Keep in mind that the buckets are manufactured with two universal quick-tach mounts, one on each side of the bucket to allow for right or left discharge.



To avoid serious personal injury make sure the bucket is securely latched to the skid-steer toolbar. Failure to do so could result in separation of the bucket from the skid-steer.

6. Connect the bucket's hydraulic hoses to the skid-steer auxiliary hydraulics using the quick couplers.
7. Turn the auxiliary hydraulics to the forward or locking position and the auger should rotate so that the material in the auger bucket is discharged through the casing at the discharge end of the auger bucket. If the material runs back up into the bucket instead of discharging, reverse the hoses at the motor end. If you are using your auger bucket for mixing, instead of discharging, the material will run back up into the bucket.

Mounting Instructions

8. Install chutes to the discharge end of your auger bucket. If using more than eight (8) feet of discharge chute we recommend welding a hook to the bucket and half way down the chutes and installing a support chain.

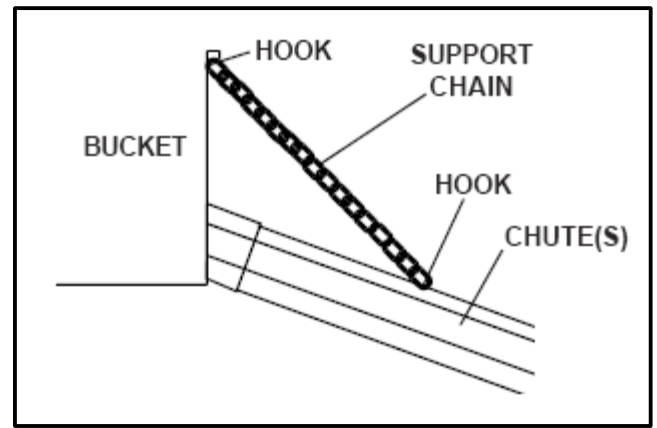

Do not coat bucket with any petroleum based agent. Damage to rubber components will occur.

Operating and Mixing Instructions

General Information

After reading all "Safety Precautions" and "Mounting Instructions" in this manual you are ready to operate your auger bucket. Be sure your work area is free of bystanders and small children. Engage the auxiliary hydraulics to discharge the concrete or material. Disengage the auxiliary hydraulics to stop the flow of concrete or material.

Mixing Instructions



Failure to follow these mixing instructions will result in excessive wear of the rubber flighting and will void manufacturer's warranty.

1. With auger bucket stationary, add the dry material (cement, sand & gravel) to the chute end of the bucket and then the liquid (water) to the motor end of the bucket.

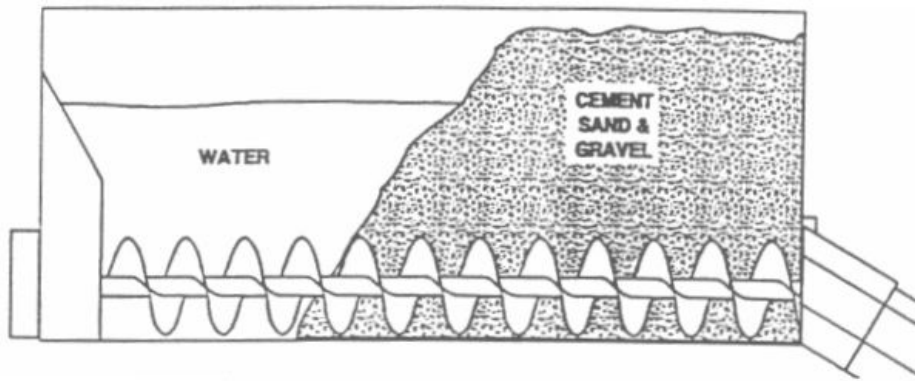

2. Run the auger in reverse. This will draw the dry material into the water and up the motor end of the bucket. The concrete mixture will roll back into the mixing material.

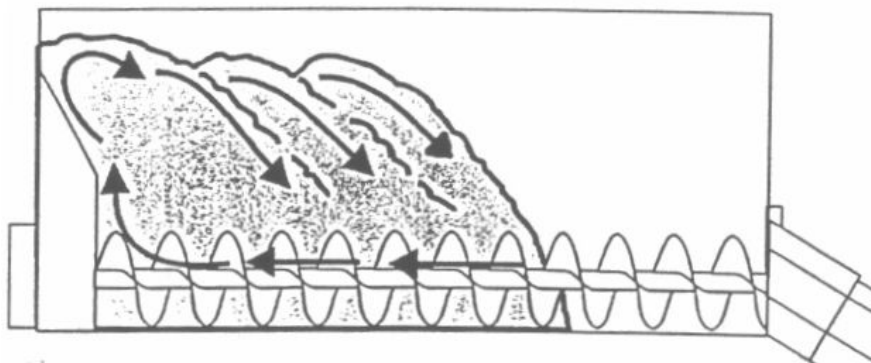

Operating and Mixing Instructions

3. Add more dry material and liquid to get the quantity and mix you require.

Note: It is recommended that you start with a wet mix and add more dry material to get the desired slump.

4. When mixing is completed, position the skid-steer so the discharge chute is directly over the forms or desired location and run the auger in the forward direction to discharge the material.

Note: One disc has been cut down in size, this disc replace the disc closest to the motor end of the bucket.

5. Replace worn rubber flights using the hardware supplied.

Note: Discharge augers require four (4) bolts per rubber flight and mixing augers require seven (7) bolts per flight.

DISCHARGE APPLICATION

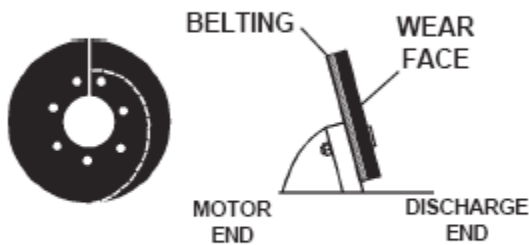

Install all rubber discs with wear face towards discharge end of the bucket.

MIXING APPLICATION

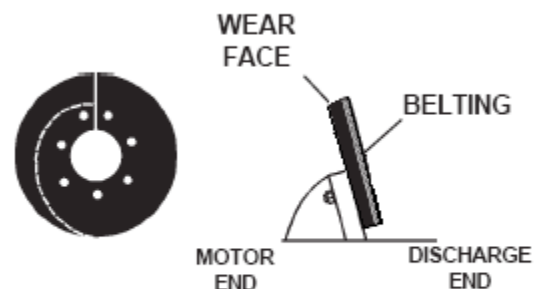

Install first seven rubber discs with wear face towards motor end, the rest towards discharge end of the bucket.

Clean Up, Removal and Storage

Clean Up Instructions

1. Run the auger bucket until all concrete or material is removed from the bucket.
2. With the operator in the skid-steer operators seat, and the auger running in reverse, have a second person add water to the discharge end of the auger bucket.



When adding or spraying water do not lean or stand in any position that will allow you to inadvertently fall into the bucket. It is recommended to use a hose and stand a safe distance away.

3. After most of the concrete or material has been cleaned from the bucket it should be raised and tilted forward to allow front access of the bucket so the second person can spray water into the bucket, therefore rinsing out any remaining material.



Do not reach hands or any other object into the bucket while hydraulic hoses are connected to the skid-steer. Severe injury could occur.

4. Tilt the bucket band and lower to the ground. Disconnect hydraulic couplers from the skid-steer and lift the splash guard at the discharge end and clean with water, making sure there is not any material or concrete between the auger and the casing.
5. Coat the bucket with a water based releasing agent. Do not allow any concrete or water to sit in the bucket; damage to the bucket and flinging could occur.

Clean Up, Removal and Storage

Removal and Storage Instructions

Store unit in a dry location

1. Clean bucket thoroughly to ensure maximum performance and auger life.
2. On firm level ground, lower the boom arms completely down onto the loader frame.
3. Turn off the engine. Move controls several times to relieve pressure in the line, then disconnect quick couplers from the auxiliary hydraulics.

Note: Connect quick couplers together to prevent contaminants from entering the bucket hydraulic system.

4. Follow your skid-steer operator's manual for detaching (removing) an attachment.
5. Coat the bucket with a water based releasing agent.

Specifications

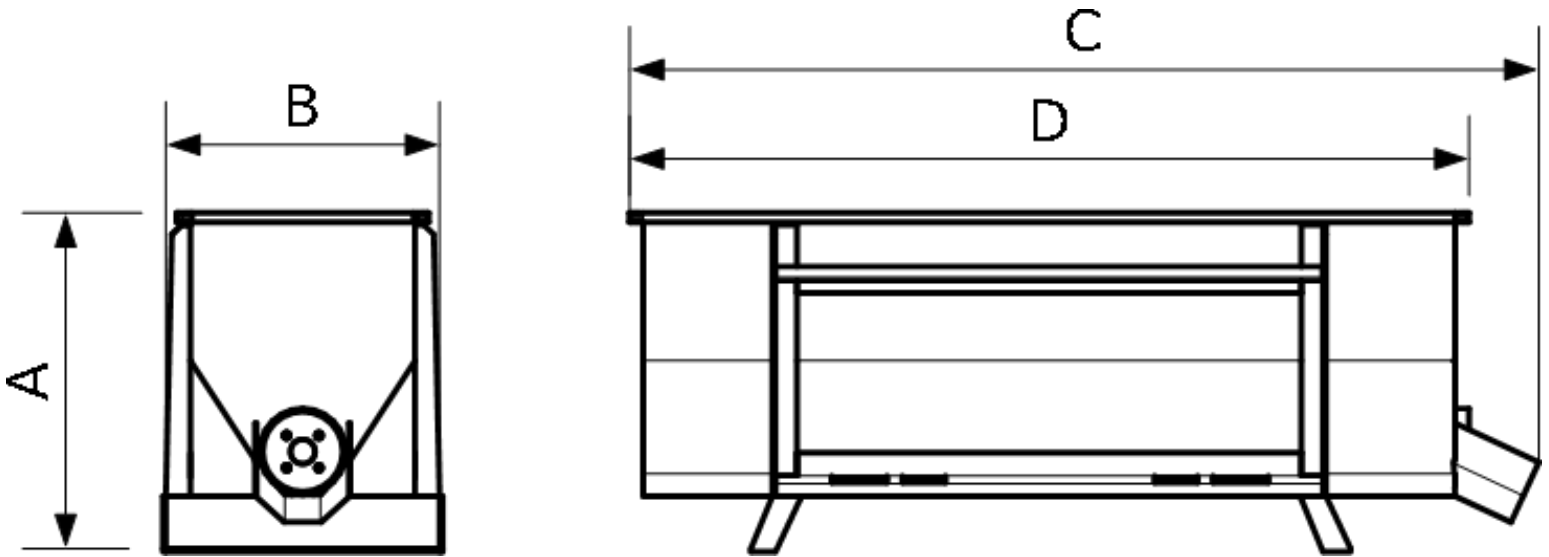

DESCRIPTION	SPECIFICATION
A. Overall Height	27.00" (68.58 cm)
B. Overall Width	22.50" (57.15 cm)
C. Overall Length	73.50" (186.6 cm)
D. Overall Bucket Length	68.00" (172.7 cm)
Weight	380 lbs (173 kg)

Hydraulic Requirements

At 12 GPM (45 LPM), 2000 PSI (138 BAR), Speed 237 R

Auger Specifications

Length	61.50" (156 cm)
Diameter without Flighting	4.00" (10.16 cm)
Diameter with Flighting	6.50" (16.51 cm)
Flighting Spacing	4.00" (10.16 cm)

All specifications and designs are subject to change without notice and without liability therefore.

Warranty

All new Talet products are warranted to be free from defects in materials or workmanship which may cause failure under normal usage and service when used for the purpose intended.

In the event of failure within twelve (12) months from initial retail sale, lease or rental date (excluding cable, ground engaging parts such as sprockets, digging chain, bearings, teeth, tamping and demolition heads, blade cutting edges, pilot bits, auger teeth, auger heads & broom bristles), if after examination, Talet determines failure was due to defective material and/or workmanship, parts will be repaired or replaced. Talet may request defective part or parts be returned prepaid to them for inspection at their place of business at Strathmore, Alberta or to a location specified by Talet.

Any claims under this warranty must be made within fifteen (15) days after the Buyer learns of the facts upon which such claim is based. All claims not made in writing and received by TALET within the time period specified above shall be deemed waived.

THIS WARRANTY IS IN LIEU OF ALL OTHER WARRANTIES EXPRESSED OR IMPLIED AND THERE ARE NO WARRANTIES OF MERCHANTABILITY OR OF FITNESS FOR A PARTICULAR PURPOSE. IN NO EVENT SHALL TALET BE LIABLE FOR CONSEQUENTIAL OR SPECIAL DAMAGE.

TALET'S LIABILITY FOR ANY AND ALL LOSSES AND DAMAGES TO BUYER, RESULTING FROM ANY CAUSE WHATSOEVER, INCLUDING TALET'S NEGLIGENCE, IRRESPECTIVE OF WHETHER SUCH DEFECTS ARE DISCOVERABLE OR LATENT, SHALL IN NO EVENT EXCEED THE PURCHASE PRICE OF THE PARTICULAR PRODUCTS WITH RESPECT TO WHICH LOSSES OR DAMAGES ARE CLAIMED, OR, AT THE ELECTION OF TALET, THE REPAIR OR REPLACEMENT OF DEFECTIVE OR DAMAGED PRODUCTS.